

# ETSI TS 101 243 V4.2.0 (2000-12)

---

*Technical Specification*

**Digital cellular telecommunications system (Phase 2);  
Enhanced Full Rate (EFR) speech processing functions;  
General description  
(3GPP TS 06.51 version 4.2.0 GSM Phase 2)**



---

**Reference**

RTS/TSGS-040651PR2

---

**Keywords**

GSM

**ETSI**

---

650 Route des Lucioles  
F-06921 Sophia Antipolis Cedex - FRANCE

Tel.: +33 4 92 94 42 00 Fax: +33 4 93 65 47 16

Siret N° 348 623 562 00017 - NAF 742 C  
Association à but non lucratif enregistrée à la  
Sous-Préfecture de Grasse (06) N° 7803/88

---

**Important notice**

Individual copies of the present document can be downloaded from:

<http://www.etsi.org>

The present document may be made available in more than one electronic version or in print. In any case of existing or perceived difference in contents between such versions, the reference version is the Portable Document Format (PDF). In case of dispute, the reference shall be the printing on ETSI printers of the PDF version kept on a specific network drive within ETSI Secretariat.

Users of the present document should be aware that the document may be subject to revision or change of status. Information on the current status of this and other ETSI documents is available at <http://www.etsi.org/tb/status/>

If you find errors in the present document, send your comment to:  
editor@etsi.fr

---

**Copyright Notification**

No part may be reproduced except as authorized by written permission.  
The copyright and the foregoing restriction extend to reproduction in all media.

© European Telecommunications Standards Institute 2000.

All rights reserved.

---

## Intellectual Property Rights

IPRs essential or potentially essential to the present document may have been declared to ETSI. The information pertaining to these essential IPRs, if any, is publicly available for **ETSI members and non-members**, and can be found in ETSI SR 000 314: "*Intellectual Property Rights (IPRs); Essential, or potentially Essential, IPRs notified to ETSI in respect of ETSI standards*", which is available from the ETSI Secretariat. Latest updates are available on the ETSI Web server (<http://www.etsi.org/ipr>).

Pursuant to the ETSI IPR Policy, no investigation, including IPR searches, has been carried out by ETSI. No guarantee can be given as to the existence of other IPRs not referenced in ETSI SR 000 314 (or the updates on the ETSI Web server) which are, or may be, or may become, essential to the present document.

---

## Foreword

This Technical Specification (TS) has been produced by the ETSI 3<sup>rd</sup> Generation Partnership Project (3GPP).

The present document may refer to technical specifications or reports using their 3GPP identities, UMTS identities or GSM identities. These should be interpreted as being references to the corresponding ETSI deliverables.

The cross reference between GSM, UMTS, 3GPP and ETSI identities can be found under [www.etsi.org/key](http://www.etsi.org/key).

---

# Contents

Foreword .....	4
1 Scope .....	5
2 References .....	5
3 Definitions and abbreviations.....	5
3.1 Definitions .....	5
3.2 Abbreviations .....	6
4 General .....	6
5 Enhanced Full Rate speech channel transcoding .....	7
6 Enhanced Full Rate speech channel discontinuous transmission (DTX).....	8
7 Enhanced Full Rate speech channel Voice Activity Detection (VAD).....	8
8 Enhanced Full Rate speech channel comfort noise insertion .....	8
9 Enhanced Full Rate speech channel lost speech frame substitution and muting.....	9
10 Enhanced Full Rate codec homing .....	9
11 Alternative Enhanced Full Rate implementation using the Adaptive Multi Rate 12.2 kbit/s mode .....	10
<b>Annex A (informative): Change Request History .....</b>	<b>11</b>

---

# Foreword

This Technical Specification has been produced by the 3<sup>rd</sup> Generation Partnership Project (3GPP).

The contents of the present document are subject to continuing work within the TSG and may change following formal TSG approval. Should the TSG modify the contents of the present document, it will be re-released by the TSG with an identifying change of release date and an increase in version number as follows:

Version x.y.z

where:

- x the first digit:
  - 1 presented to TSG for information;
  - 2 presented to TSG for approval;
  - 3 or greater indicates TSG approved document under change control.
- y the second digit is incremented for all changes of substance, i.e. technical enhancements, corrections, updates, etc.
- z the third digit is incremented when editorial only changes have been incorporated in the document.

---

# 1 Scope

The present document is an introduction to GSM 06.60 (EN 301 245) [6], GSM 06.61 (EN 301 246) [7], GSM 06.62 (EN 301 247) [8], GSM 06.81 (EN 301 248) [9] and GSM 06.82 (EN 301 249) [10] ENs dealing with the speech processing functions in the Enhanced Full Rate channel of the GSM system. A general overview of the speech processing functions is given, with reference to the ENs where each function is specified in detail.

---

# 2 References

The following documents contain provisions which, through reference in this text, constitute provisions of the present document.

- References are either specific (identified by date of publication, edition number, version number, etc.) or non-specific.
- For a specific reference, subsequent revisions do not apply.
- For a non-specific reference, the latest version applies.
- A non-specific reference to an ETS shall also be taken to refer to later versions published as an EN with the same number.

- [1] GSM 01.04 (ETR 100): "Digital cellular telecommunications system (Phase 2); Abbreviations and acronyms".
- [2] GSM 03.50 (ETS 300 540): "Digital cellular telecommunications system (Phase 2); Transmission planning aspects of the speech service in the GSM Public Land Mobile Network (PLMN) system".
- [3] GSM 05.03 (ETS 300 575): "Digital cellular telecommunications system (Phase 2); Channel coding".
- [4] GSM 06.53 (EN 301 244): "Digital cellular telecommunications system (Phase 2); ANSI-C code for the GSM Enhanced Full Rate (EFR) speech codec".
- [5] GSM 06.54 (EN 301 250): "Digital cellular telecommunications system (Phase 2); Test vectors for the GSM Enhanced Full Rate (EFR) speech codec".
- [6] GSM 06.60 (EN 301 245): "Digital cellular telecommunications system (Phase 2); Enhanced Full Rate (EFR) speech transcoding".
- [7] GSM 06.61 (EN 301 246): "Digital cellular telecommunications system (Phase 2); Substitution and muting of lost frame for Enhanced Full Rate (EFR) speech traffic channels".
- [8] GSM 06.62 (EN 301 247): "Digital cellular telecommunications system (Phase 2); Comfort noise aspects for Enhanced Full Rate (EFR) speech traffic channels".
- [9] GSM 06.81 (EN 301 248): "Digital cellular telecommunications system (Phase 2); Discontinuous transmission (DTX) for Enhanced Full Rate (EFR) speech traffic channels".
- [10] GSM 06.82 (EN 301 249): "Digital cellular telecommunications system (Phase 2); Voice Activity Detector (VAD) for Enhanced Full Rate (EFR) speech traffic channels".

---

# 3 Definitions and abbreviations

## 3.1 Definitions

Definition of terms used in the present document can be found in GSM 06.60 (EN 301 245) [6], GSM 06.61 (EN 301 246) [7], GSM 06.62 (EN 301 247) [8], GSM 06.81 (EN 301 248) [9] and GSM 06.82 (EN 301 249) [10].

## 3.2 Abbreviations

For the purposes of the present document, the following abbreviations apply:

ACELP	Algebraic Code Excited Linear Prediction
BFI	Bad Frame Indication
BSS	Base Station System
CCITT	Comité Consultatif International Télégraphique et Téléphonique
DTX	Discontinuous Transmission
ETS	European Telecommunication Standard
GSM	Global System for Mobile communications
MS	Mobile Station
PCM	Pulse Code Modulated
PLMN	Public Land Mobile Network
PSTN	Public Switched Telephone Network
RF	Radio Frequency
RSS	Radio SubSystem
RX	Receive
SACCH	Slow Associated Control CHannel
SID	SIlence Descriptor
SP flag	SPeech flag
TAF	Time Alignment Flag
TX	Transmit

For abbreviations not given in this subclause, see GSM 01.04 (ETR 100) [1].

## 4 General

Figure 1 presents a reference configuration where the various speech processing functions are identified. In this figure, the relevant Standards for each function are also indicated.

In figure 1, the audio parts including analogue to digital and digital to analogue conversion are included, to show the complete speech path between the audio input/output in the Mobile Station (MS) and the digital interface of the PSTN. The detailed specification of the audio parts are contained in GSM 03.50 (ETS 300 540) [2]. These aspects are only considered to the extent that the performance of the audio parts affect the performance of the speech transcoder.

An alternative and fully interoperable implementation using as a basis the 12.2 kbit/s mode of the Adaptive Multi Rate speech coder is described in section 11.

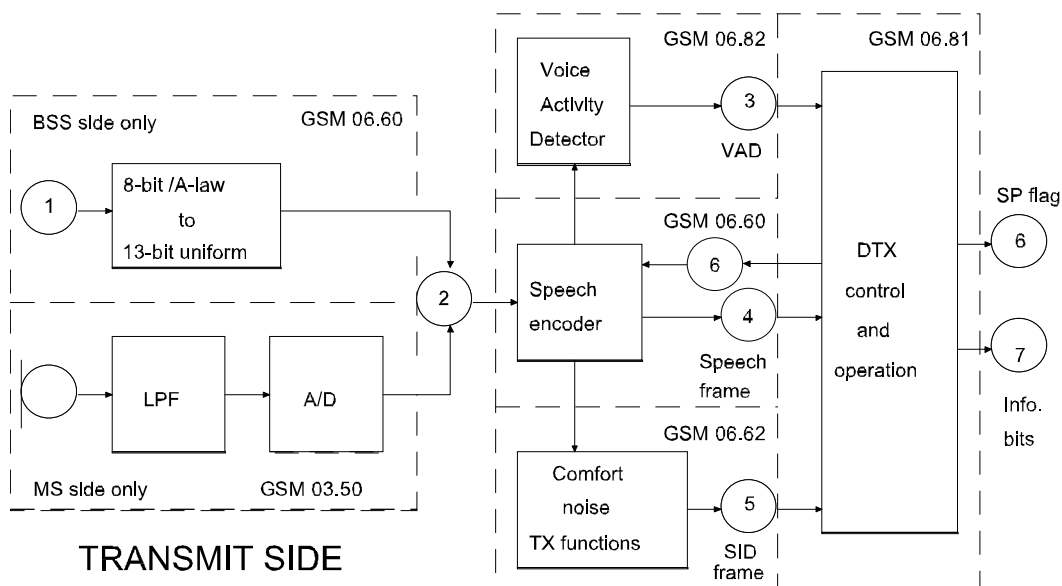

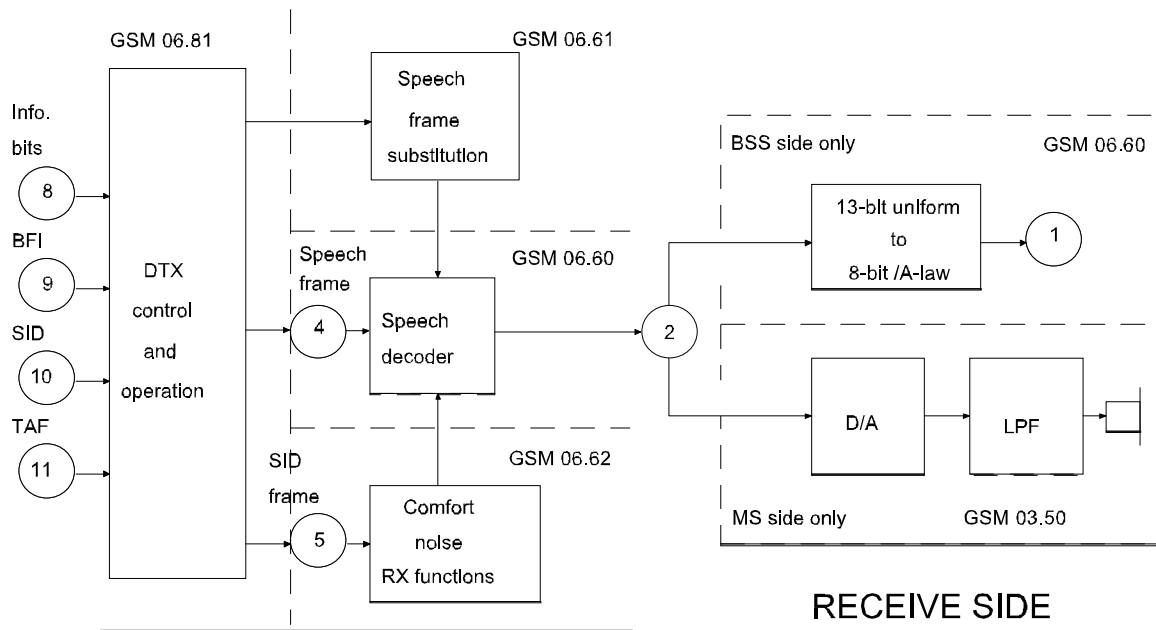

- 1) 8-bit /A-law PCM (CCITT recommendation G.711), 8 000 samples/s
- 2) 13-bit uniform PCM, 8 000 samples/s
- 3) Voice Activity Detector (VAD) flag
- 4) Encoded speech frame, 50 frames/s, 244 bits/frame
- 5) Silence Descriptor (SID) frame, 244 bits/frame
- 6) SPeech (SP) flag, indicates whether information bits are speech or SID information
- 7) Information bits delivered to the radio subsystem
- 8) Information bits received from the radio subsystem
- 9) Bad Frame Indication
- 10) Silence Descriptor (SID) flag
- 11) Time Alignment Flag (TAF), marks the position of the SID frame within the Slow Associated Control CHannel (SACCH) multiframe

**Figure 1: Overview of audio processing functions**

## 5 Enhanced Full Rate speech channel transcoding

As shown in figure 1, the speech encoder takes its input as a 13-bit uniform Pulse Code Modulated (PCM) signal either from the audio part of the Mobile Station or on the network side, from the Public Switched Telephone Network (PSTN) via an 8-bit/A-law to 13-bit uniform PCM conversion. The encoded speech at the output of the speech encoder is delivered to the channel coding function defined in GSM 05.03 (ETS 300 575) [3] to produce an encoded block consisting of 456 bits leading to a gross bit rate of 22,8 kbit/s.

In the receive direction, the inverse operations take place. GSM 06.60 (EN 301 245) [6] describes the detailed mapping between input blocks of 160 speech samples in 13-bit uniform PCM format to encoded blocks of 244 bits and from encoded blocks of 244 bits to output blocks of 160 reconstructed speech samples. The sampling rate is 8 000 sample/s leading to a bit rate for the encoded bit stream of 12,2 kbit/s. The coding scheme is the so-called Algebraic Code Excited Linear Prediction, hereafter referred to as ACELP.

GSM 06.60 (EN 301 245) [6] describes the codec and GSM 06.53 (EN 301 244) [4] defines the C code, thus enabling the verification of compliance to GSM 06.60 (EN 301 245) [6] to a high degree of confidence by use of a set of digital test sequences given in GSM 06.54 (EN 301 250) [5].



---

## 6 Enhanced Full Rate speech channel discontinuous transmission (DTX)

During a normal phone conversation, the participants alternate so that, on the average, each direction of transmission is occupied about 50 % of the time. Discontinuous transmission (DTX) is a mode of operation where the transmitters are switched on only for those frames which contain useful information. This may be done for the following two purposes:

- 1) In the MS, battery life will be prolonged or a smaller battery could be used for a given operational duration.
- 2) The average interference level over the air interface is reduced, leading to better Radio Frequency (RF) spectrum efficiency.

The overall DTX mechanism is implemented in the DTX handlers (Transmit (TX) and Receive (RX)) described in GSM 06.81 (EN 301 248) [9] and requires the following functions:

- a Voice Activity Detector (VAD) on the TX side, see GSM 06.82 (EN 301 249) [10];
- evaluation of the background acoustic noise on the TX side, in order to transmit characteristic parameters to the RX side, see GSM 06.62 (EN 301 247) [8];
- generation of comfort noise on the RX side during periods where the radio transmission is turned off, see GSM 06.62 (EN 301 247) [8].

The transmission of comfort noise information to the RX side is achieved by means of a Silence Descriptor (SID) frame. The SID frame is transmitted at the end of speech bursts and serves as an end of speech marker for the RX side. In order to update the comfort noise characteristics at the RX side, SID frames are transmitted at regular intervals also during speech pauses. This also serves the purpose of improving the measurement of the radio link quality by the Radio SubSystem (RSS).

The DTX handlers interwork with the RSS using flags. The RSS is in control of the actual transmitter keying on the TX side, and performs various pre-processing functions on the RX side. This is described in GSM 06.81 (EN 301 248) [9].

The speech flag (SP) indicates whether information bits are speech or SID information. The SP flag is calculated from the VAD flag by the TX DTX handler. When SID information is transmitted (SP="0") the operation of the speech encoder is modified to reduce the remaining computation for that frame. This is described in GSM 06.62 (EN 301 247) [8].

---

## 7 Enhanced Full Rate speech channel Voice Activity Detection (VAD)

The Enhanced Full Rate VAD function is described in GSM 06.82 (EN 301 249) [10].

The input to the VAD is a set of parameters computed by the Enhanced Full Rate speech encoder defined in GSM 06.60 (EN 301 245) [6]. The VAD uses this information to decide whether each 20 ms speech coder frame contains speech or not. Note that the VAD flag is an input to TX DTX handler and does not control the transmitter keying directly.

GSM 06.82 (EN 301 249) [10] describes the VAD algorithm and GSM 06.53 (EN 301 244) [4] defines the C code. The verification of compliance to GSM 06.82 (EN 301 249) [10] is achieved by use of digital test sequences (see GSM 06.54 (EN 301 250) [5]) applied to the same interface as the test sequences for the speech codec.

---

## 8 Enhanced Full Rate speech channel comfort noise insertion

The Enhanced Full Rate noise comfort insertion function is described in GSM 06.62 (EN 301 247) [8].

When switching the transmission on and off during DTX operation, the effect would be a modulation of the background noise at the receiving end, if no precautions were taken. When transmission is on, the background noise is transmitted

together with the speech to the receiving end. As the speech burst ends, the connection is off and the perceived noise would drop to a very low level. This step modulation of noise may be perceived as annoying and reduce the intelligibility of speech, if presented to a listener without modification.

This "noise contrast effect" is reduced in the GSM system by inserting an artificial noise, termed comfort noise, at the receiving end when speech is absent.

The comfort noise processes are as follows:

- the evaluation of the acoustic background noise in the transmitter;
- the noise parameter encoding (SID frames) and decoding;
- and the generation of comfort noise in the receiver.

The comfort noise processes and the algorithm for updating the noise parameters during speech pauses are defined in detail in GSM 06.62 (EN 301 247) [8].

The comfort noise mechanism is based on the Enhanced Full Rate speech codec defined in GSM 06.60 (EN 301 245) [6].

---

## 9 Enhanced Full Rate speech channel lost speech frame substitution and muting

The Enhanced Full Rate speech frame substitution and muting function is described in GSM 06.61 (EN 301 246) [7].

In the receiver, frames may be lost due to transmission errors or frame stealing. GSM 06.61 (EN 301 246) [7] describes the actions to be taken in these cases, both for lost speech frames and for lost SID frames in DTX operation.

In order to mask the effect of an isolated lost frame, the lost speech frame is substituted by a predicted frame based on previous frames. Insertion of silence frames is not allowed. For several subsequent lost frames, a muting technique shall be used to indicate to the listener that transmission has been interrupted.

---

## 10 Enhanced Full Rate codec homing

The GSM Enhanced Full Rate speech transcoder, VAD, DTX system and comfort noise parts of the audio processing functions (see figure 1) are defined in bit exact arithmetic. Consequently, they shall react on a given input sequence always with the corresponding bit exact output sequence, provided that the internal state variables are also always exactly in the same state at the beginning of the experiment.

The input test sequences provided in GSM 06.54 (EN 301 250) [5] shall force the corresponding output test sequences, provided that the tested modules are in their home-state when starting.

The modules may be set into their home states by provoking the appropriate homing-functions.

NOTE: This is normally done during reset (initialization of the codec).

Special inband signalling frames (encoder-homing-frame and decoder-homing-frame) described in GSM 06.60 (EN 301 245) [6] have been defined to provoke these homing-functions also in remotely placed modules.

This mechanism is specified to support three main areas:

- type approval of mobile terminal equipment;
- type approval of infrastructure equipment;
- remote control and testing for operation and maintenance.

At the end of the first received homing frame, the audio functions that are defined in a bit exact way shall go into their predefined home states. The output corresponding to the first homing frame is dependent on the codec state when the frame was received. Any consecutive homing frames shall produce corresponding homing frames at the output.

---

## 11 Alternative Enhanced Full Rate implementation using the Adaptive Multi Rate 12.2 kbit/s mode

The 12.2 kbit/s mode of the Adaptive Multi Rate speech coder described in TS 26.071 is functionally equivalent to the GSM Enhanced Full Rate speech coder. An alternative implementation of the Enhanced Full Rate speech service based on the 12.2 kbit/s mode of the Adaptive Multi Rate coder is allowed. Alternative implementations shall implement the functionality specified in TS 26.071 for the 12.2 kbit/s mode, with the difference that the DTX transmission format from GSM 06.81, the comfort noise generation from GSM 06.62 and the decoder-homing-frame from GSM 06.60 shall be used.

Verification of compliance using the alternative implementation is achieved by use of a set of digital test sequences given in GSM 06.54.

**NOTE:** The alternative implementation of the GSM Enhanced Full Rate speech coder incurs an additional 5ms look-ahead delay, and the implementation in this specification (GSM 06.51) is the preferred option.

---

## Annex A (informative): Change Request History

SMG#	Tdoc SMG	Spec	CR	Cat	PH	Vers	New Vers	Subject
32	P-00-273	06.51	A004	B	Ph 2	4.0.1	4.1.0	Alternative EFR implementation using the AMR 12.2 mode

TSG-SA#	TD	Spec	CR	Cat	PH	Old Vers	New Vers	Subject
10	SP-000572	06.51	A009	F	Ph 2	4.1.0	4.2.0	Definition of the homing frame for the alternative EFR implementation

---

## History

<b>Document history</b>		
V4.0.0	August 1997	One-step Approval Procedure OAP 9750: 1997-08-15 to 1997-12-12
V4.0.1	December 1997	Publication as EN 301 243
V4.1.0	July 2000	One-step Approval Procedure OAP 20001124: 2000-07-26 to 2000-11-24
V4.1.1	November 2000	Publication as EN 301 243
V4.2.0	December 2000	Publication