

# ETSI TS 123 303 V12.2.0 (2014-09)



**Universal Mobile Telecommunications System (UMTS);  
LTE;  
Proximity-based services (ProSe);  
Stage 2  
(3GPP TS 23.303 version 12.2.0 Release 12)**



---

**Reference**

DTS/TSGS-0223303vc20

---

**Keywords**

LTE,UMTS

**ETSI**

650 Route des Lucioles  
F-06921 Sophia Antipolis Cedex - FRANCE

---

Tel.: +33 4 92 94 42 00 Fax: +33 4 93 65 47 16

Siret N° 348 623 562 00017 - NAF 742 C  
Association à but non lucratif enregistrée à la  
Sous-Préfecture de Grasse (06) N° 7803/88

---

**Important notice**

The present document can be downloaded from:

<http://www.etsi.org>

The present document may be made available in electronic versions and/or in print. The content of any electronic and/or print versions of the present document shall not be modified without the prior written authorization of ETSI. In case of any existing or perceived difference in contents between such versions and/or in print, the only prevailing document is the print of the Portable Document Format (PDF) version kept on a specific network drive within ETSI Secretariat.

Users of the present document should be aware that the document may be subject to revision or change of status. Information on the current status of this and other ETSI documents is available at

<http://portal.etsi.org/tb/status/status.asp>

If you find errors in the present document, please send your comment to one of the following services:

[http://portal.etsi.org/chaicor/ETSI\\_support.asp](http://portal.etsi.org/chaicor/ETSI_support.asp)

---

**Copyright Notification**

No part may be reproduced or utilized in any form or by any means, electronic or mechanical, including photocopying and microfilm except as authorized by written permission of ETSI.

The content of the PDF version shall not be modified without the written authorization of ETSI.

The copyright and the foregoing restriction extend to reproduction in all media.

© European Telecommunications Standards Institute 2014.

All rights reserved.

**DECT™**, **PLUGTESTS™**, **UMTS™** and the ETSI logo are Trade Marks of ETSI registered for the benefit of its Members. **3GPP™** and **LTE™** are Trade Marks of ETSI registered for the benefit of its Members and of the 3GPP Organizational Partners.

**GSM®** and the GSM logo are Trade Marks registered and owned by the GSM Association.

---

## Intellectual Property Rights

IPRs essential or potentially essential to the present document may have been declared to ETSI. The information pertaining to these essential IPRs, if any, is publicly available for **ETSI members and non-members**, and can be found in ETSI SR 000 314: *"Intellectual Property Rights (IPRs); Essential, or potentially Essential, IPRs notified to ETSI in respect of ETSI standards"*, which is available from the ETSI Secretariat. Latest updates are available on the ETSI Web server (<http://ipr.etsi.org>).

Pursuant to the ETSI IPR Policy, no investigation, including IPR searches, has been carried out by ETSI. No guarantee can be given as to the existence of other IPRs not referenced in ETSI SR 000 314 (or the updates on the ETSI Web server) which are, or may be, or may become, essential to the present document.

---

## Foreword

This Technical Specification (TS) has been produced by ETSI 3rd Generation Partnership Project (3GPP).

The present document may refer to technical specifications or reports using their 3GPP identities, UMTS identities or GSM identities. These should be interpreted as being references to the corresponding ETSI deliverables.

The cross reference between GSM, UMTS, 3GPP and ETSI identities can be found under <http://webapp.etsi.org/key/queryform.asp>.

---

## Modal verbs terminology

In the present document "**shall**", "**shall not**", "**should**", "**should not**", "**may**", "**may not**", "**need**", "**need not**", "**will**", "**will not**", "**can**" and "**cannot**" are to be interpreted as described in clause 3.2 of the [ETSI Drafting Rules](#) (Verbal forms for the expression of provisions).

"**must**" and "**must not**" are **NOT** allowed in ETSI deliverables except when used in direct citation.

# Contents

Intellectual Property Rights .....	2
Foreword.....	2
Modal verbs terminology.....	2
Foreword.....	6
1 Scope .....	7
2 References .....	7
3 Definitions and abbreviations.....	8
3.1 Definitions .....	8
3.2 Abbreviations .....	10
4 Architecture Model and Concepts.....	10
4.1 General Concept .....	10
4.2 Architectural Reference Model .....	10
4.3 Reference points .....	13
4.3.1 List of Reference Points.....	13
4.4 Functional Entities.....	14
4.4.1 ProSe Function.....	14
4.4.1.1 General .....	14
4.4.1.2 ProSe Function Discovery.....	16
4.4.2 UE.....	16
4.4.3 ProSe UE-to-Network Relay.....	17
4.4.4 ProSe Application Server.....	17
4.4.5 MME.....	17
4.5 High Level Function.....	18
4.5.1 Provisioning for ProSe Direct Discovery and ProSe Direct Communication.....	18
4.5.1.1 Authorization and provisioning for ProSe.....	18
4.5.1.1.1 General .....	18
4.5.1.1.2 Provisioning information for ProSe Direct Discovery and ProSe Direct Communication.....	18
4.5.2 Subscription to ProSe.....	21
4.5.3 IP address allocation .....	21
4.5.4 ProSe UE-to-Network Relaying .....	22
4.5.5 ProSe Proxy Function .....	22
4.6 Identifiers .....	23
4.6.1 Identifiers for EPC-level ProSe Discovery .....	23
4.6.2 Identifiers for EPC support for WLAN direct discovery and communication.....	23
4.6.3 Identifiers for ProSe Direct Communication .....	23
4.6.3.1 ProSe UE ID.....	23
4.6.3.2 ProSe Layer-2 Group ID .....	23
4.6.4 Identifiers for ProSe Direct Discovery.....	23
4.6.4.1 ProSe Application ID .....	23
4.6.4.2 ProSe Application Code.....	23
4.6.4.2a Discovery Filter.....	24
4.6.4.2b ProSe Application Mask .....	25
4.6.4.3 Identifiers for ProSe UE-to-Network Relay discovery and selection.....	25
5 Functional Description and Information Flow .....	25
5.1 Control and user plane stacks .....	25
5.1.1 Control Plane .....	25
5.1.1.1 General .....	25
5.1.1.2 UE - ProSe Function .....	26
5.1.1.3 HSS - ProSe Function .....	26
5.1.1.4 SLP - ProSe Function.....	26
5.1.1.5 UE - UE.....	27
5.1.1.6 ProSe Function - ProSe Function .....	27

5.1.1.7	ProSe Function - ProSe Application Server .....	28
5.1.2	User Plane .....	28
5.1.2.1	UE - UE .....	28
5.1.2.2	UE - UE-to-Network Relay .....	29
5.2	Service authorisation and revocation for ProSe Direct Discovery and ProSe Direct Communication .....	30
5.2.1	Service authorisation procedures .....	30
5.2.2	Service authorization update procedures .....	31
5.2.2.1	General .....	31
5.2.2.2	HSS triggered ProSe direct Service authorization update .....	31
5.2.2.3	ProSe function triggered ProSe Direct Service revocation (non-roaming) .....	32
5.2.2.4	ProSe function triggered ProSe Direct Service revocation (roaming) .....	33
5.3	ProSe Direct Discovery .....	33
5.3.1	General .....	33
5.3.1.1	Overview .....	33
5.3.1.2	ProSe Direct Discovery Models .....	34
5.3.2	Overall procedure for ProSe Direct Discovery (Model A) .....	35
5.3.3	Discovery Request .....	36
5.3.3.1	General .....	36
5.3.3.2	Announce request (non-roaming) .....	36
5.3.3.3	Announce request (roaming) .....	37
5.3.3.4	Monitor request (non-roaming) .....	38
5.3.3.5	Monitor request (roaming) .....	39
5.3.4	Discovery reporting .....	41
5.3.4.1	Match report (non-roaming) .....	41
5.3.4.2	Match reporting (roaming) .....	42
5.4	Procedures for ProSe Direct Communication .....	43
5.4.1	One-to-many ProSe Direct Communication general .....	43
5.4.2	One-to-many ProSe Direct Communication transmission .....	43
5.4.3	One-to-many ProSe Direct Communication reception .....	44
5.4.4	Direct communication via ProSe UE-to-Network Relay .....	45
5.4.4.1	General .....	45
5.4.4.2	IPv6 Stateless Address auto-configuration .....	46
5.4.4.3	IPv4 Address allocation using DHCPv4 .....	47
5.5	EPC-level ProSe Discovery procedures .....	47
5.5.1	General .....	47
5.5.2	Overall call flow for EPC-level ProSe Discovery .....	48
5.5.3	UE registration for ProSe .....	48
5.5.4	Application registration for ProSe .....	49
5.5.5	Proximity Request .....	50
5.5.6	UE Location Reporting .....	51
5.5.7	Proximity Alert .....	51
5.5.8	UE deregistration for ProSe .....	52
5.5.8.1	General .....	52
5.5.8.2	Network-initiated deregistration .....	52
5.5.8.3	UE-initiated deregistration .....	53
5.5.9	Proximity Request Cancellation .....	53
5.6	EPC support for WLAN direct discovery and communication .....	54
5.6.1	General .....	54
5.6.2	Enabling of EPC assisted WLAN direct communication .....	54
5.6.3	Revocation of EPC assisted WLAN direct communication .....	55
5.7	ProSe impacts to EPC procedures .....	56
5.7.1	E-UTRAN attach procedure for ProSe-enabled UEs .....	56
5.7.2	Service Request procedures for ProSe-enabled UEs .....	56
5.7.3	PS Handover procedures for ProSe-enabled UEs .....	57
5.7.4	Tracking Area Update procedure for ProSe-enabled UEs .....	57
5.7.5	Insert Subscriber Data procedure for ProSe-enabled UEs .....	57

**Annex A (informative): Assistance Information for EPC support for WLAN direct discovery and communication.....58**

A.1	General .....	58
-----	---------------	----

A.2 Wi-Fi Peer-to-Peer .....58

**Annex B (informative): Wild carded ProSe Application IDs .....59**

B.1 General .....59

B.2 Use of wild-carded ProSe Application IDs .....59

**Annex C (Informative): Change history .....61**

History .....62

---

# Foreword

This Technical Specification has been produced by the 3<sup>rd</sup> Generation Partnership Project (3GPP).

The contents of the present document are subject to continuing work within the TSG and may change following formal TSG approval. Should the TSG modify the contents of the present document, it will be re-released by the TSG with an identifying change of release date and an increase in version number as follows:

Version x.y.z

where:

- x the first digit:
  - 1 presented to TSG for information;
  - 2 presented to TSG for approval;
  - 3 or greater indicates TSG approved document under change control.
- y the second digit is incremented for all changes of substance, i.e. technical enhancements, corrections, updates, etc.
- z the third digit is incremented when editorial only changes have been incorporated in the document.

---

# 1 Scope

The present document specifies the Stage 2 of the Proximity Services (ProSe) features in EPS. ProSe features consist of: ProSe discovery (direct or EPC-level) and ProSe Direct Communication (using E-UTRAN or WLAN direct).

ProSe discovery identifies that ProSe-enabled UEs are in proximity, using E-UTRAN (with or without E-UTRAN) or EPC.

ProSe Direct Communication enables establishment of communication paths between two or more ProSe-enabled UEs that are in direct communication range. The ProSe Direct Communication path could use E-UTRAN or WLAN.

For Public Safety specific usage:

- Public Safety ProSe-enabled UEs can establish the communication path directly between two or more Public Safety ProSe-enabled UEs, regardless of whether the Public Safety ProSe-enabled UE is served by E-UTRAN.
- ProSe Direct Communication is also facilitated by the use of a ProSe UE-to-Network Relay, which acts as a relay between E-UTRAN and UEs not served by E-UTRAN.

Security aspects of ProSe are defined in TS 33.303 [29].

In this Release of the specification, there is no support for ProSe UE-to-Network Relays.

---

# 2 References

The following documents contain provisions which, through reference in this text, constitute provisions of the present document.

- References are either specific (identified by date of publication, edition number, version number, etc.) or non-specific.
- For a specific reference, subsequent revisions do not apply.
- For a non-specific reference, the latest version applies. In the case of a reference to a 3GPP document (including a GSM document), a non-specific reference implicitly refers to the latest version of that document *in the same Release as the present document*.

- [1] 3GPP TR 21.905: "Vocabulary for 3GPP Specifications".
- [2] Open Mobile Alliance, OMA AD SUPL: "Secure User Plane Location Architecture", (<http://www.openmobilealliance.org>).
- [3] 3GPP TS 23.032: "Universal Geographical Area Description (GAD)".
- [4] 3GPP TS 23.218: "IP Multimedia (IM) session handling; IM call model".
- [5] 3GPP TS 23.401: "General Packet Radio Service (GPRS) enhancements for Evolved Universal Terrestrial Radio Access Network (E-UTRAN) access".
- [6] IETF RFC 4862: "IPv6 Stateless Address Autoconfiguration".
- [7] IETF RFC 2131: "Dynamic Host Configuration Protocol".
- [8] IETF RFC 4039: "Rapid Commit Option for the Dynamic Host Configuration Protocol version 4 (DHCPv4)".
- [9] 3GPP TS 23.402: "Architecture enhancements for non-3GPP accesses".
- [10] IETF RFC 4861: "Neighbor Discovery for IP version 6 (IPv6)".
- [11] 3GPP TS 23.221: "Architectural requirements".
- [12] 3GPP TS 23.003: "Numbering, addressing and identification".



- [13] Wi-Fi Alliance Technical Committee P2P Task Group, "Wi-Fi Peer-to-Peer (P2P) Technical Specification", Version 1.1.
- [14] IEEE Std 802.11-2012: "IEEE Standard for Information technology - Telecommunications and information exchange between systems - Local and metropolitan area networks - Specific requirements - Part 11: Wireless LAN Medium Access Control (MAC) and Physical Layer (PHY) Specifications".
- [15] 3GPP TS 29.061: "Interworking between the Public Land Mobile Network (PLMN) supporting packet based services and Packet Data Networks (PDN)".
- [16] IETF RFC 3927: "Dynamic Configuration of IPv4 Link-Local Addresses".
- [17] 3GPP TS 36.300: "Evolved Universal Terrestrial Radio Access (E-UTRA) and Evolved Universal Terrestrial Radio Access Network (E-UTRAN); Overall description; Stage 2".
- [18] IETF RFC 3588: "Diameter Base Protocol".
- [19] IETF RFC 4960: "Stream Control Transmission Protocol".
- [20] Open Mobile Alliance, OMA LIF MLP: "Mobile Location Protocol", (<http://www.openmobilealliance.org>).
- [21] 3GPP TS 29.343: "Proximity-services (ProSe) Function to Proximity-services (ProSe) Application Server aspects (PC2); Stage 3".
- [22] 3GPP TS 29.344: "Proximity-services (ProSe) Function to Home Subscriber Server (HSS) aspects (PC4a); Stage 3".
- [23] 3GPP TS 29.345: "Inter-Proximity-services (ProSe) Function signalling aspects (PC6/PC7); Stage 3".
- [24] 3GPP TS 24.334: "Proximity-services (ProSe) User Equipment (UE) to Proximity-services (ProSe) Function aspects (PC3); Stage 3".
- [25] 3GPP TS 22.278: "Service requirements for the Evolved Packet System (EPS)".
- [26] 3GPP TS 23.468: "Group Communication System Enablers for LTE (GCSE\_LTE); Stage 2".
- [27] Void.
- [28] IETF RFC 826: "An Ethernet Address Resolution Protocol".
- [29] 3GPP TS 33.303: "Proximity-based Services (ProSe); Security aspects".
- [30] OMA-TS-DM\_Protocol-V1\_2: "OMA Device Management Protocol".

---

## 3 Definitions and abbreviations

### 3.1 Definitions

For the purposes of the present document, the terms and definitions given in TR 21.905 [1] and the following apply. A term defined in the present document takes precedence over the definition of the same term, if any, in TR 21.905 [1].

**Application ID:** A globally unique identifier identifying a specific application. All mobile operating systems have namespaces that identify the applications within the mobile operating system.

**Application Layer User ID:** An identity identifying a user within the context of a specific application (e.g. [alice@social.net](mailto:alice@social.net)). The format of this identifier is outside the scope of 3GPP.

**Destination Layer-2 ID:** A link-layer identity that identifies a device or a group of devices that are recipients of ProSe communication frames.

**Discovery Filter:** A container of ProSe Application Masks and/or ProSe Application Codes and Time To Live value(s). These are used by the monitoring UE to match ProSe Application Codes that are received on the PC5 interface for Direct Discovery.

**EPC ProSe User ID:** An identifier for EPC-level ProSe Discovery and EPC support for WLAN direct communication that uniquely identifies a UE registered for ProSe. This identifier can be occasionally reassigned by the ProSe Function.

**EPC-level ProSe Discovery:** A ProSe Discovery procedure by which the EPC determines the proximity of two ProSe-enabled UEs and informs them of their proximity.

**Local PLMN:** A PLMN which is not the serving PLMN of the monitoring UE, and in whose radio resources the monitoring UE is authorized by the HPLMN to engage in ProSe Direct Discovery.

**Model A:** involves one UE announcing "I am here"

**Model B:** involves one UE asking "who is there" and/or "are you there"

**ProSe Application ID:** The ProSe Application ID is an identity used for ProSe Direct Discovery, identifying application related information for the ProSe-enabled UE. Each ProSe Application ID could be globally unique, e.g. in case of open Direct Discovery.

**ProSe Application Code:** The ProSe Application Code is associated with the ProSe Application ID and used in the discovery procedures.

**ProSe Application Mask:** The ProSe Application Mask is provided by the ProSe Function in order to allow the monitoring UE to perform partial matching of ProSe Application Codes on the PC5 interface.

**ProSe Direct Communication:** A communication between two or more UEs in proximity that are ProSe-enabled, by means of user plane transmission using E-UTRA technology via a path not traversing any network node.

**ProSe Direct Discovery:** A procedure employed by a ProSe-enabled UE to discover other ProSe-enabled UEs in its vicinity by using only the capabilities of the two UEs with E-UTRA technology.

**ProSe Discovery:** A process that identifies that a UE that is ProSe-enabled is in proximity of another, using E-UTRA (with or without E-UTRAN) or EPC.

**ProSe Function ID:** An FQDN that identifies a ProSe Function.

**ProSe Layer-2 Group ID:** A pre-configured layer-2 group identifier that may be used to address a set of users at the 3GPP lower layers.

**ProSe-enabled non-Public Safety UE:** A UE that supports ProSe procedures but not capabilities specific to Public Safety.

**ProSe-enabled Public Safety UE:** A UE that the HPLMN has configured to be authorized for Public Safety use, and which is ProSe-enabled and supports ProSe procedures and capabilities specific to Public Safety. The UE may, but need not, have a USIM with one of the special access classes {12, 13, 14}.

**ProSe-enabled UE:** A UE that supports ProSe requirements and associated procedures. Unless explicitly stated otherwise, a ProSe-enabled UE refers both to a non-Public Safety UE and a Public Safety UE.

**ProSe UE-to-Network Relay:** A UE that provides functionality to support connectivity to "unicast" services for Remote UE(s).

**Remote UE:** A ProSe-enabled Public Safety UE, that is not served by E-UTRAN, and that communicates with a PDN via a ProSe UE-to-Network Relay.

**Source Layer-2 ID:** A link-layer identity that identifies a device that originates ProSe communication frames.

**WLAN Link Layer ID:** A link layer identity used for WLAN direct discovery and/or WLAN direct communication. Depending on the WLAN technology it can be temporary (e.g. temporary MAC address) or permanent (e.g. permanent MAC address). The format of this identifier depends on the WLAN technology and is outside of 3GPP scope.

For the purposes of the present document, the following terms and definitions given in TS 22.278 [25] apply:

## Open ProSe Discovery

## 3.2 Abbreviations

For the purposes of the present document, the abbreviations given in TR 21.905 [1] and the following apply. An abbreviation defined in the present document takes precedence over the definition of the same abbreviation, if any, in TR 21.905 [1].

ALUID	Application Layer User ID
DPF	Direct Provisioning Function
EPUID	EPC ProSe User ID
PFID	ProSe Function ID
ProSe	Proximity-based Services
SLP	SUPL Location Platform
SUPL	Secure User Plane Location
TTL	Time to Live
WLLID	WLAN Link Layer ID

---

# 4 Architecture Model and Concepts

## 4.1 General Concept

Proximity Services (ProSe) are services that can be provided by the 3GPP system based on UEs being in proximity to each other.

The 3GPP system enablers for ProSe include the following functions:

- EPC-level ProSe Discovery;
- EPC support for WLAN direct discovery and communication;
- Direct discovery;
- Direct communication;
- UE-to-Network Relay.

## 4.2 Architectural Reference Model

Figure 4.2-1 shows the high level view of the non-roaming architecture. In this figure, UE A and UE B use a subscription of the same PLMN.

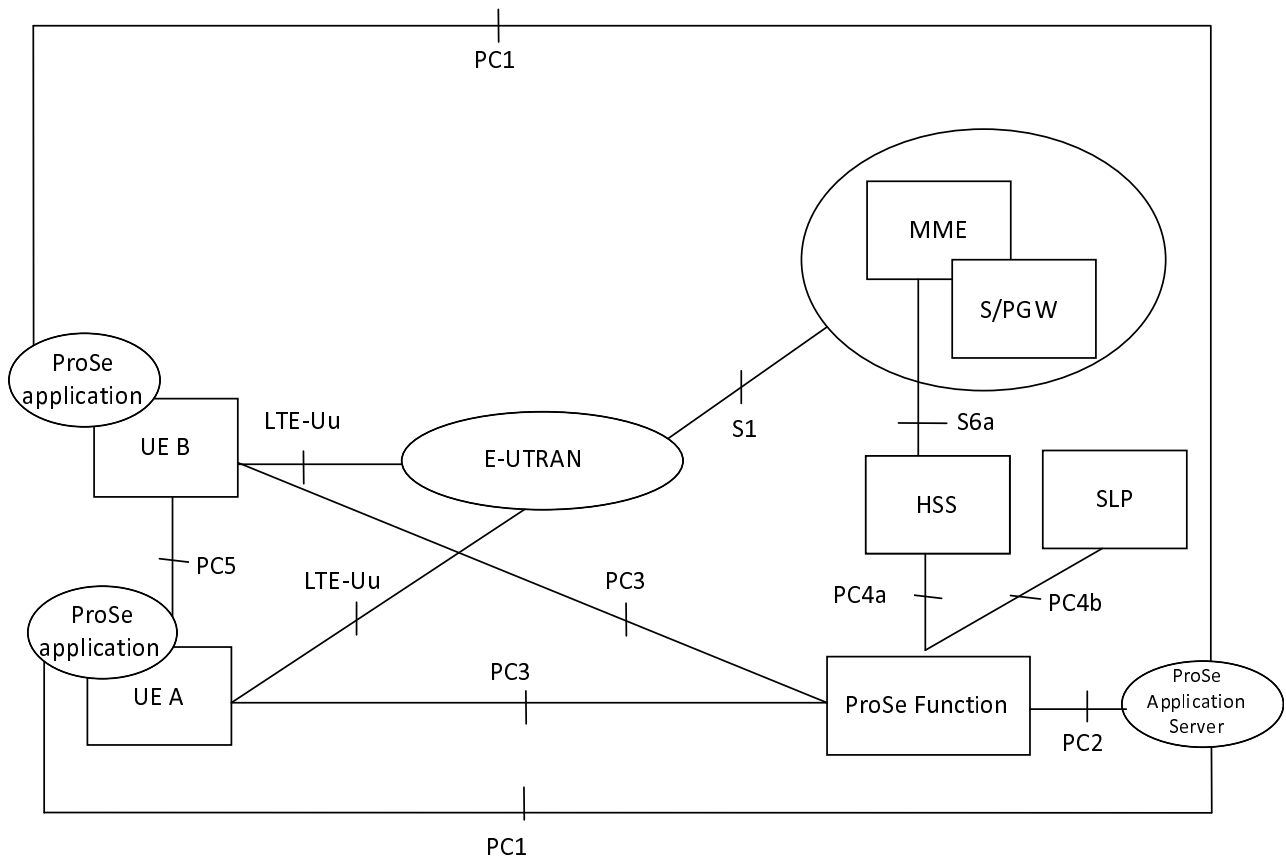

**Figure 4.2-1: Non-Roaming Reference Architecture**

The following figure 4.2-2 show the high level view of the non-roaming inter-PLMN architecture. In this figure, PLMN A is the HPLMN of UE A and PLMN B is the HPLMN of UE B.

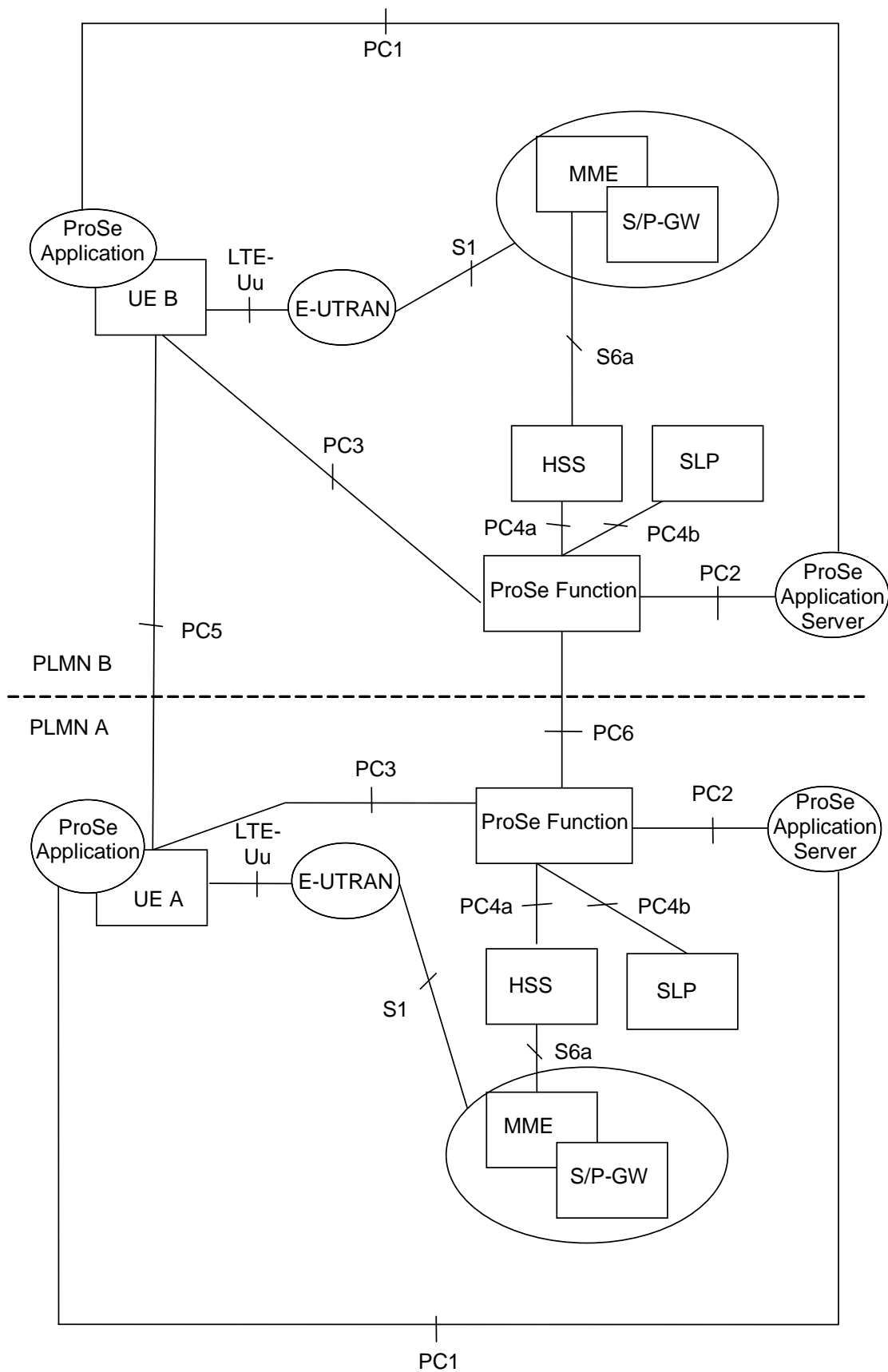

**Figure 4.2-2: Inter-PLMN Reference Architecture**

Figure 4.2-3 shows the high level view of the roaming architecture. In this figure, UE A uses a subscription of PLMN A and UE B uses a subscription of PLMN B; UE A is roaming in PLMN C while UE B is not roaming.

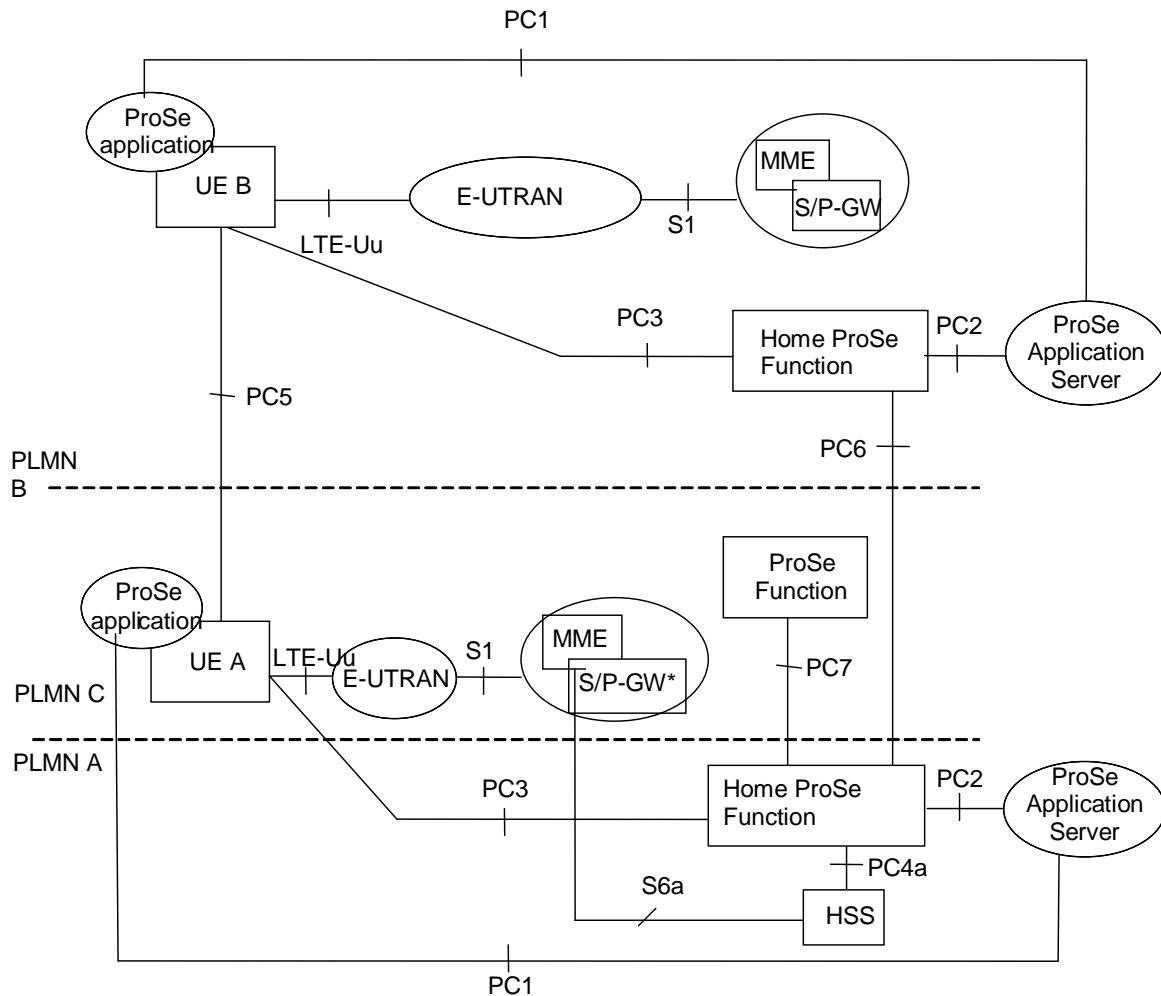

**Figure 4.2-3: Roaming Reference Architecture**

NOTE: For EPC-level ProSe discovery the roaming architecture is not specified in this release.

## 4.3 Reference points

### 4.3.1 List of Reference Points

- PC1:** The reference point between the ProSe application in the UE and in the ProSe Application Server. It is used to define application level signalling requirements. This reference point is not specified in this release of the specification.
- PC2:** The reference point between the ProSe Application Server and the ProSe Function. It is used to define the interaction between ProSe Application Server and ProSe functionality provided by the 3GPP EPS via ProSe Function (e.g. name translation) for EPC-level ProSe discovery.
- PC3:** The reference point between the UE and the ProSe Function. PC3 relies on EPC user plane for transport (i.e. an "over IP" reference point). It is used to authorise ProSe Direct Discovery and EPC-level ProSe Discovery requests, and perform allocation of ProSe Application Codes corresponding to ProSe Application Identities used for ProSe Direct Discovery. It is used to define the authorisation policy per PLMN for ProSe Direct Discovery (for Public Safety and non -Public Safety) and communication (for Public Safety only) between UE and ProSe Function.
- PC4a:** The reference point between the HSS and ProSe Function. It is used to provide subscription information in order to authorise access for ProSe Direct Discovery and ProSe Direct Communication on a per PLMN basis. It is also used by the ProSe Function (i.e. EPC-level ProSe Discovery Function) for retrieval of EPC-level ProSe Discovery related subscriber data.

- PC4b:** The reference point between the SUPL Location Platform (SLP) defined in OMA AD SUPL [2] and the ProSe Function. It is used by the ProSe Function (i.e. EPC-level ProSe Discovery Function) (in the role of LCS client to query the SLP defined in OMA AD SUPL [2].
- PC5:** The reference point between ProSe-enabled UEs used for control and user plane for ProSe Direct Discovery, ProSe Direct Communication and ProSe UE-to-Network Relay.
- PC6:** The reference point between ProSe Functions in different PLMNs (EPC-level ProSe Discovery) or between the ProSe Function in the HPLMN and the ProSe Function in a Local PLMN (ProSe Direct Discovery). With ProSe Direct Discovery this reference point is used for HPLMN control of ProSe service authorization. It is also used to authorise ProSe Direct Discovery requests, retrieve the Discovery Filter(s) corresponding ProSe Application ID name(s) and translate the ProSe Application Code to the ProSe Application ID Name.
- PC7:** The reference point between the ProSe Function in the HPLMN and the ProSe Function in the VPLMN. It is used for HPLMN control of ProSe service authorization. It is also used to authorise ProSe Direct Discovery requests, retrieve the Discovery Filter(s) corresponding ProSe Application ID name(s) and translate the ProSe Application Code to the ProSe Application ID Name.
- S6a:** In addition to the relevant functions defined in TS 23.401 [5] for S6a, in case of ProSe S6a is used to download ProSe related subscription information to MME during E UTRAN attach procedure or to inform MME subscription information in the HSS has changed.
- S1-MME:** In addition to the relevant functions defined in TS 23.401 [5] for S1-MME, in case of ProSe it is also used to provide an indication to eNB that the UE is authorised to use ProSe Direct Discovery.

## 4.4 Functional Entities

### 4.4.1 ProSe Function

#### 4.4.1.1 General

The ProSe Function is the logical function that is used for network related actions required for ProSe. The ProSe Function plays different roles for each of the features of ProSe. In this version of the specification it is assumed that there is only one logical ProSe Function in each PLMN that supports Proximity Services.

- NOTE:** If multiple ProSe Functions are deployed within the same PLMN (e.g., for load reasons), then the method to locate the ProSe Function that has allocated a specific ProSe Application Code (e.g. through a database lookup, etc.) is not defined in this version of the specification.

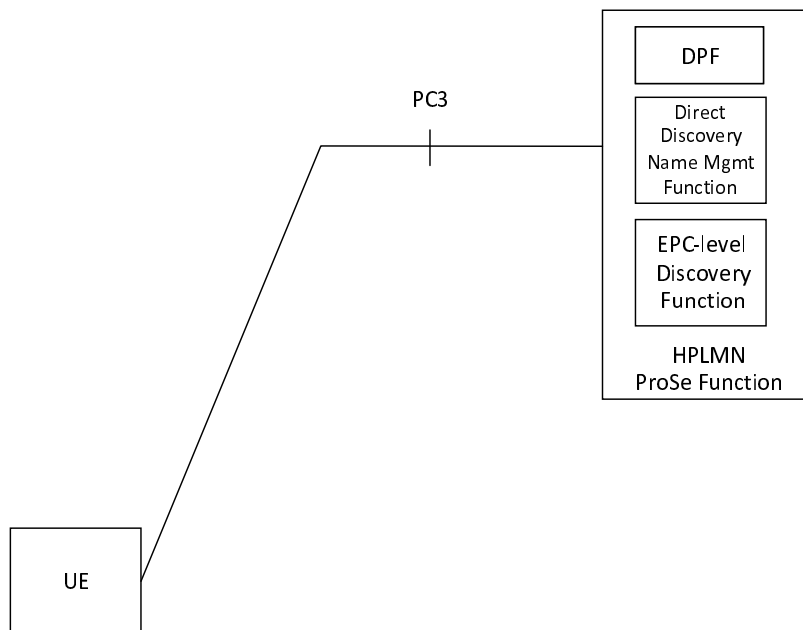

**Figure 4.4.1-1: UE to ProSe Function Interfaces for each sub-function**

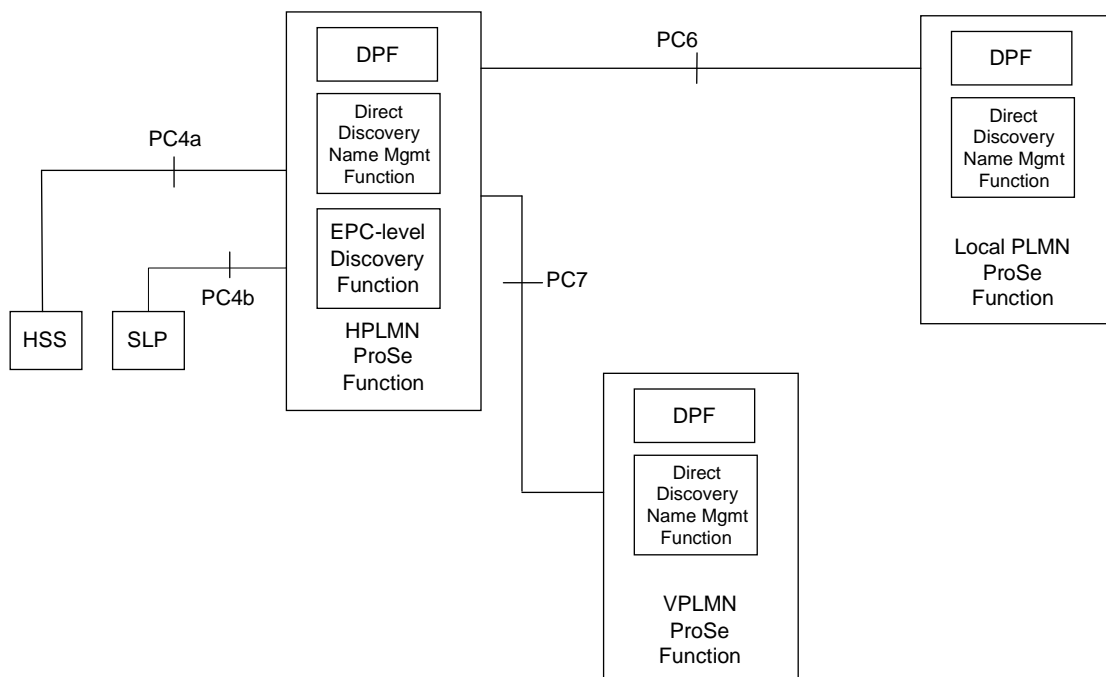

**Figure 4.4.1-2: ProSe Function Interfaces to other network elements and PLMNs**

The ProSe Function consists of three main sub-functions that perform different roles depending on the ProSe feature:

- Direct Provisioning Function (DPF) is used to provision the UE with necessary parameters in order use ProSe Direct Discovery and Prose Direct Communication. It is used to provision the UEs with PLMN specific parameters that allow the UE to use ProSe in this specific PLMN. For direct communication used for Public Safety DPF is also used to provision the UE with parameters that are needed when the UE is not served by E-UTRAN.
- Direct Discovery Name Management Function is used for open Prose Direct Discovery to allocate and process the mapping of ProSe Applications IDs and ProSe Application Codes used in ProSe Direct Discovery. It uses ProSe related subscriber data stored in HSS for authorisation for each discovery request. It also provides the UE with the necessary security material in order to protect discovery messages transmitted over the air.



- EPC-level Discovery ProSe Function has a reference point towards the Application Server (PC2), towards other ProSe Functions (PC6), towards the HSS (PC4a) and the UE (PC3). The functionality includes the following:
  - Storage of ProSe-related subscriber data and/or retrieval of ProSe-related subscriber data from the HSS;
  - Authorization and configuration of the UE for EPC-level ProSe Discovery and EPC-assisted WLAN direct discovery and communication over PC3;
  - Storage of a list of applications that are authorized to use EPC-level ProSe Discovery and EPC-assisted WLAN direct discovery and communication;
  - Acting as location services client (SLP agent) to enable EPC-level ProSe Discovery;
  - Providing the UE with information to assist WLAN direct discovery and communications;
  - Handling of EPC ProSe User IDs and Application Layer User IDs;
  - Exchange of signalling with 3<sup>rd</sup> party Application Servers over PC2 reference point for application registration and identifier mapping;
  - Exchange of signalling with ProSe Functions in other PLMNs over PC6 reference points for sending proximity requests, proximity alerts and location reporting;
  - Optional support for functionality for requesting UE location via the HSS.

The ProSe Function provides the necessary charging and security functionality for usage of ProSe (both ProSe via the EPC and for ProSe Direct Discovery, ProSe Direct Communication and WLAN direct discovery and communication).

NOTE: The ProSe Function in HPLMN can be always reached if Home Routed configuration is applied for PDN connection (e.g. PDN GW is located in the HPLMN), when such function is supported by the HPLMN. In case of Local Breakout (e.g. PDN GW is located in the VPLMN), a ProSe Proxy Function can be deployed by the VPLMN to support UE to Home ProSe Function communication, if inter-PLMN signalling is required. Whether a PDN connection is provided by Local Breakout or Home Routed is determined by the HSS configuration described in 3GPP TS 23.401 [5]. UE is not aware of this and as such will not know which APN can be used for communication with ProSe Function unless a specific APN for ProSe is configured.

#### 4.4.1.2 ProSe Function Discovery

The ProSe Functions of HPLMN is discovered through interaction with the Domain Name Service function. The FQDN of a ProSe Function in the Home PLMN may either be pre-configured on the UE or provisioned by the network or self-constructed by the UE, e.g. derived from PLMN ID of the HPLMN. The IP address of a ProSe Function in the Home PLMN may also be provisioned to the UE.

#### 4.4.2 UE

Any ProSe-enabled UE may support the following functions:

- Exchange of ProSe control information between ProSe-enabled UE and the ProSe Function over PC3 reference point.
- Procedures for open ProSe Direct Discovery of other ProSe-enabled UEs over PC5 reference point.

The ProSe-enabled Public Safety UE may support the following functions:

- Procedures for one-to-many ProSe Direct Communication over PC5 reference point.
- Procedures to act as a ProSe UE-to-Network Relay. The Remote UE communicates with the ProSe UE-to-Network Relay over PC5 reference point. The ProSe UE-to-Network Relay uses layer-3 packet forwarding.
- Exchange of control information between ProSe UEs over PC5 reference point, e.g. for UE-to-Network Relay detection and ProSe Direct Discovery.

- Exchange of ProSe control information between another ProSe-enabled UE and the ProSe Function over PC3 reference point. In the ProSe UE-to-Network Relay case the Remote UE will send this control information over PC5 user plane to be relayed over the LTE-Uu interface towards the ProSe Function.
- Configuration of parameters (e.g. including IP addresses, ProSe Layer-2 Group IDs, Group security material, radio resource parameters). These parameters can be pre-configured in the UE, or, if in coverage, provisioned by signalling over the PC3 reference point to the ProSe Function in the network.

### 4.4.3 ProSe UE-to-Network Relay

The ProSe UE-to-Network Relay entity provides the functionality to support connectivity to "unicast" services for Remote UEs that are not "served by E-UTRAN" (see figure 4.4.3-1).

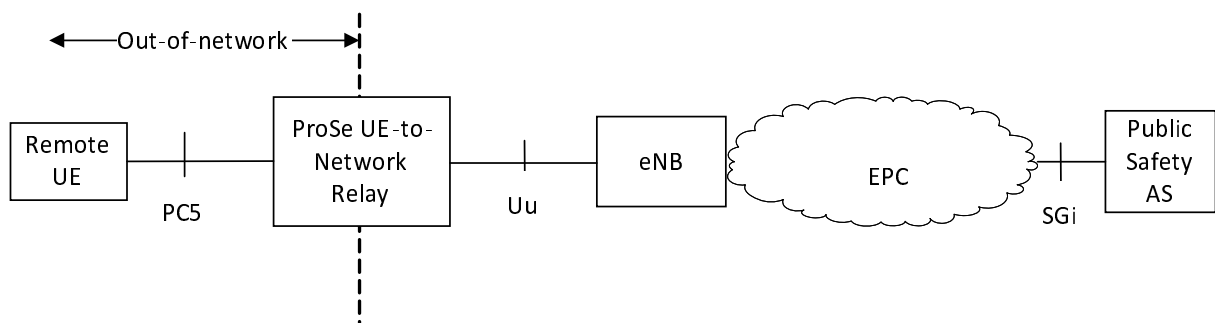

**Figure 4.4.3-1: ProSe UE-to-Network Relay**

The ProSe UE-to-Network Relay shall relay unicast traffic (UL and DL) between the Remote UE and the network. The ProSe UE-to-Network Relay shall provide generic function that can relay any type of traffic that is relevant for public safety communication.

NOTE 1: There is no support for relaying eMBMS traffic from Uu interface to PC5 in this release of the specification.

NOTE 2: The IP Address preservation is not supported when the Remote UE moves out of the ProSe UE-to-Network Relay coverage.

One-to-one Direct Communication between Remote UEs and ProSe UE-to-Network Relays has the following characteristics:

- Communication over PC5 reference point is connectionless.
- ProSe Bearers are bi-directional. IP packets passed to the radio layers on a given ProSe bearer will be transmitted by the physical layer with the associated L2 destination address. IP packets passed up from the radio layers on the same ProSe bearer will have been received over the air addressed to the same L2 destination.

### 4.4.4 ProSe Application Server

The ProSe Application Server supports the following capability:

- Storage of EPC ProSe User IDs and ProSe Function IDs;
- Mapping of Application Layer User IDs and EPC ProSe User IDs.

### 4.4.5 MME

In addition to the function defined in TS 23.401 [5] in case of ProSe MME performs the following functions:

- receives subscription information related to ProSe from HSS;
- provides indication to E-UTRAN that the UE is authorized to use ProSe.

## 4.5 High Level Function

### 4.5.1 Provisioning for ProSe Direct Discovery and ProSe Direct Communication

#### 4.5.1.1 Authorization and provisioning for ProSe

##### 4.5.1.1.1 General

The basic principles of service authorization for ProSe Direct Discovery and ProSe Direct Communication are as follows:

- the UE gets authorization to use ProSe Direct Discovery on a per PLMN basis.
- the UE gets authorization to use ProSe Direct Communication on a per PLMN basis in the serving PLMN by the ProSe Function in the HPLMN,
- the ProSe Function in the HPLMN requests authorisation information from the ProSe Function of the serving PLMN and Local PLMN(s).

NOTE: The UE does not need to be registered in the Local PLMN.

- The ProSe Function in the HPLMN merges authorization information from home, serving and local PLMNs.
- Final authorization always comes from the ProSe Function in the Home PLMN.

The ProSe Function in the Local PLMN or the VPLMN or HPLMN may revoke the authorization at any time. The ProSe Function in the HPLMN shall be notified when authorization is revoked by the Local PLMN or the VPLMN.

OMA DM [30] is used as the protocol to provision ProSe related configuration and authorization information in the ME. Provisioning is performed via the PC3 reference point.

#### 4.5.1.1.2 Provisioning information for ProSe Direct Discovery and ProSe Direct Communication

##### 4.5.1.1.2.1 General

The following information can be contained in the authorisation info that is provided by the ProSe Function to the UE for authorisation of using ProSe Direct Discovery and ProSe Direct Communication in a particular PLMN.

For Public Safety usage the operator may pre-configure ProSe-enabled Public Safety UEs with the required provisioning parameters for ProSe Direct Discovery and ProSe Direct Communication, without the need for the ProSe-enabled Public Safety UEs to connect to the ProSe Function to get this initial configuration. The following apply:

- The provisioning parameters for ProSe Direct Discovery and ProSe Direct Communication may be configured in the UICC, in the ME, or in both the UICC and the ME.
- The ME provisioning parameters shall have additional information that enables the ProSe-enabled Public Safety ME to determine whether the ProSe Direct Discovery and ProSe Direct Communication are permitted to be used by the UE with the selected USIM.
- ProSe Direct Discovery and ProSe Direct Communication shall be accessible only when a USIM authorized for ProSe Direct Discovery and ProSe Direct Communication is selected.
- The ME provisioning parameters shall not be erased when a USIM is deselected or replaced.
- If both the USIM and the ME contain the same set of provisioning parameters, the set of parameters from the UICC shall take precedence.

- While a UE is being served by E-UTRAN and the UE intends to use the radio resources (frequency bands etc) operated by the serving E-UTRAN cell for ProSe, then the UE shall use the radio resource description indicated by the E-UTRAN cell the UE is camping on and ignore any radio resource description of the same radio resource provisioned in the ME or the UICC.

NOTE 1: It is possible for a UE to use other radio resources for ProSe than those operated by the serving E-UTRAN cell, when provisioned in the UE, even if the UE is camping on this cell where it receives normal service and the ProSe SIB indicates that the service (discovery or communication or both) is available. This is to cover the scenario when e.g. the radio resources used for ProSe Direct Communication are not owned by the serving network of the cell being camped on.

NOTE 2: The UE can only use ProSe Direct Discovery and ProSe Direct Communication when it contains a UICC that has been configured for ProSe and the ME has been provisioned with information to permit the selected USIM.

#### 4.5.1.1.2.2 Authorisation for ProSe Direct Discovery (non-Public Safety UE)

The following information is provisioned to the UE for ProSe Direct Discovery authorisation:

1) ProSe Direct Discovery monitoring authorisation policy:

- PLMNs in which the UE is authorised to perform ProSe Direct Discovery monitoring:
  - For each PLMN in the list, whether the UE is pre-authorised by the HPLMN to perform ProSe Direct Discovery monitoring or it is conditionally authorised, in which case the UE would need to contact the ProSe Function of that PLMN (e.g. when it is in that country) in order to obtain authorisation.

2) ProSe Direct Discovery announcing authorisation policy:

- PLMNs in which the UE is authorized to perform announcing:
  - For each PLMN in the list, whether the UE is pre-authorised by the HPLMN to perform ProSe Direct Discovery announcing or it is conditionally authorised, in which case the UE would need to contact the ProSe Function of that PLMN (e.g. when it is in that country) in order to obtain authorisation.
- Authorised discovery range for announcing per PLMN.

#### 4.5.1.1.2.3 Provisioning for ProSe Direct Discovery and ProSe Direct Communication (Public Safety UE)

##### 4.5.1.1.2.3.1 General

The content of clause 4.5.1.1.2.3 is applicable to ProSe-enabled Public Safety UEs only.

Clause 3 provides the definition of a ProSe-enabled Public Safety UE. To comply with international and national regulations, the HPLMN shall endeavour to ensure that the UE only uses the specific Public Safety capabilities in territories in which the HPLMN is authorised to permit such rights to the UE.

##### 4.5.1.1.2.3.2 Additional provisioning information for ProSe Direct Discovery

In addition to the parameters indicated in clause 4.5.1.1.2.2, the ProSe-enabled Public Safety UE is provisioned with the following information:

1) Authorisation policy when the UE is "not served by E-UTRAN":

- Indicates whether the UE is authorised to perform ProSe Direct Discovery when "not served by E-UTRAN"

2) Radio parameters for when the UE is "not served by E-UTRAN":

- Includes the radio parameters that need to be configured in the UE in order to be able perform ProSe Direct Discovery procedures when not "served by E-UTRAN". This includes e.g. frequency bands.

NOTE: These parameters are defined in TS 36.300 [17].

#### 4.5.1.1.2.3.3 Provisioning information for one-to-many ProSe Direct Communication

NOTE 1: ProSe Direct Communication one-to-one is not specified in this version of the 3GPP specifications.

The following information is provisioned to the UE for one-to-many ProSe Direct Communication:

1) Authorisation policy:

- When the UE is "served by E-UTRAN":
  - PLMNs in which the UE is authorised to perform one-to-many ProSe Direct Communication
    - For each PLMN in the list, whether the UE is pre-authorised by the HPLMN to perform one-to-many ProSe Direct Communication, or, it is conditionally authorised, in which case the UE would need to contact the ProSe Function of that PLMN (e.g. when it is in this country) in order to obtain authorisation.
- When the UE is "not served by E-UTRAN":
  - Indicates whether the UE is authorised to perform one-to-many ProSe Direct Communication procedures when "not served by E-UTRAN".

2) ProSe Direct Communication policy/parameters:

- Include the parameters that enable the UE to perform one-to-many ProSe Direct Communication when provisioned from DPF:
  - ProSe Layer-2 Group ID;
  - ProSe Group IP multicast address
  - Indication whether the UE should use IPv4 or IPv6 for that group
  - For a specific Group configured to operate using IPv4, optionally an IPv4 address to be used by the UE as a source address. If none is provisioned, then the UE shall use Dynamic Configuration of IPv4 Link-Local Addresses IETF RFC 3927 [16] to obtain a link local address for the Group.
  - Include group security related content for one-to-many ProSe Direct Communication.

NOTE 2: More details on the necessary security aspect will be defined in SA3 specifications.

- Alternatively these parameters can be provided from the 3rd party public safety provider application server (e.g. GCS AS as in TS 23.468 [26]). If UE receives the same set of data from AS that has been previously provided by DPF then UE uses the data set provided by AS for one-to-many ProSe Direct Communication.

3) Radio parameters for when the UE is "not served by E-UTRAN":

- Includes the radio parameters that need to be configured in the UE in order to be able perform one-to-many ProSe Direct Communication procedures when "not served by E-UTRAN". This includes e.g. frequency bands.

NOTE 3: These parameters are defined in TS 36.300 [17].

#### 4.5.1.1.2.3.4 Additional provisioning information in support of ProSe UE-to-Network Relay

In addition to the parameters indicated in clauses 4.5.1.1.2.3.2 and 4.5.1.1.2.3.3, the ProSe-enabled Public Safety UE is provisioned with the following information in support of ProSe UE-to-Network Relay:

1) Authorisation policy for acting as a ProSe UE-to-Network Relay when the UE is "served by E-UTRAN":

- Indicates whether the UE is authorised to relay traffic for Remote UEs that are "not served by E-UTRAN"

NOTE: The ProSe-enabled Public Safety UE gets the configuration parameters from the ProSe Functions in service authorization.

## 4.5.2 Subscription to ProSe

The user's profile in the HSS contains the subscription information to give the user permission to use ProSe.

At any time, the operator can remove the ProSe UE subscription rights from user's profile in the HSS, and revoke the user's permission to use ProSe.

The following subscription information is defined for ProSe:

- subscription for ProSe Direct Discovery.
- subscription for EPC-level ProSe Discovery.
- subscription for EPC support WLAN direct discovery and communication.
- subscription for one-to-many ProSe Direct Communication, applicable only to ProSe-enabled Public Safety UEs.
- subscription for ProSe UE-to-Network Relay, applicable only to ProSe-enabled Public Safety UEs.

Additional parameters related to the ProSe Direct service may be stored in the user's profile, such as:

- the list of the PLMNs where the UE is authorised for Direct Discovery, i.e. to announce or monitor or both.
- the list of the PLMNs where the UE is authorised to perform one-to-many ProSe Direct Communication.

## 4.5.3 IP address allocation

For one-to-many ProSe Direct Communication:

- when the UE is configured to use IPv6 on the direct link, the UE auto-configures a link local IPv6 Address following procedures defined in RFC 4862 [6]. This address can only be used as the source IP address for one-to-many ProSe Direct Communication.
- when the UE is configured to use IPv4 for a certain Group for one-to-many ProSe Direct Communication, then either it uses the configured IPv4 address for the Group or, if it is not configured with an address for the Group, it uses Dynamic Configuration of IPv4 Link-Local Addresses IETF RFC 3927 [16].

For communication with a ProSe UE-to-Network Relay:

- a) When the ProSe UE-to-Network Relay uses a PDN connection with PDN type IPv4 for the traffic with Remote UEs:
  - a1) The IPv4 address allocation and IPv4 parameter configuration via DHCPv4 is performed according to RFC 2131 [7] and RFC 4039 [8] procedures. The IPv4 address provided to the Remote UE from the ProSe UE-to-Network Relay by DHCPv4 procedure shall correspond to a local IPv4 address range configured in the ProSe UE-to-Network Relay.
  - a2) The DHCPv4 request from the Remote UE is always sent subsequent to the discovery of the ProSe UE-to-Network Relay. It is sent to the L2 link address of the Relay corresponding to the PDN connection the Remote UE has selected.
  - a3) If the IPv4 address is allocated by using DHCPv4 procedure, then after the UE releases the IPv4 address using DHCPv4 or the IPv4 address lease time expires, the same IPv4 address shall not be allocated to another Remote UE immediately by the ProSe UE-to-Network Relay.
- b) When the ProSe UE-to-Network Relay uses a PDN connection with PDN type IPv6 for the traffic with Remote UEs:
  - b1) IPv6 network prefix allocation via IPv6 Stateless Address auto-configuration:
    - b1.1) Router solicitation from the Remote UE is always sent subsequent to the discovery of the ProSe UE-to-Network Relay. It is sent to the L2 link layer ID of the Relay corresponding to the PDN connection the Remote UE has selected. The IPv6 network prefix assigned to the Remote UE is sent in the Router Advertisement.

- b.1.2) The IPv6 network prefix is assigned to the ProSe UE-to-Network Relay using existing procedures described in TS 23.401 [5] and TS 23.402 [9]. For stateless address auto-configuration however, the UE can choose any interface identifier to generate an IPv6 address, other than link-local, without involving the network. Any prefix that the ProSe UE-to-Network Relay will advertise to the Remote UE is unique: there is no need for the Remote UE to perform Duplicate Address Detection for global uniqueness for any IPv6 address configured from the allocated IPv6 network prefix.
- b2) IPv6 parameter configuration via Stateless DHCPv6: The UE may use stateless DHCPv6 for additional parameter configuration.
- c) When the ProSe UE-to-Network Relay uses a PDN connection with PDN type IPv4v6, or has both PDN type IPv4 and type IPv6 available for the traffic with Remote UEs:
- The IPv6 network prefix allocation via IPv6 Stateless Address auto-configuration procedure, IPv6 parameter configuration via Stateless DHCPv6 procedure and DHCPv4 procedure are the same as for PDN type IPv6 or IPv4 defined in previous bullets.

#### 4.5.4 ProSe UE-to-Network Relaying

ProSe UE-to-Network Relaying shall include the following functions:

- ProSe Direct discovery following Model A or Model B can be used in order to allow the Remote UE to discover ProSe UE-to-Network Relay(s) in proximity.
- ProSe Direct discovery that can be used in order to allow the Remote UE to discover L2 address of the ProSe UE-to-Network Relay to be used by the Remote UE for IP address allocation and user plane traffic corresponding to a specific PDN connection supported by the ProSe UE-to-Network Relay.
- Act as an "announcing" or "discoveree" UE on the PC5 reference point supporting direct discovery.
- Act as a default router to the Remote UEs forwarding IP packets between the UE-ProSe UE-to-Network Relay point-to-point link and the corresponding PDN connection.
- Handle Router Solicitation and Router Advertisement messages as defined in IETF RFC 4861[10].
- Act as DHCPv4 Server and stateless DHCPv6 Relay Agent.
- Act as a NAT if IPv4 is used replacing the locally assigned IPv4 address of the Remote UE with its own.
- Map the L2 link ID used by the Remote UE as Destination Layer-2 ID to the corresponding PDN connection supported by the ProSe UE-to-Network Relay.

NOTE: The aspects of the radio layers for the PC5 reference point are defined in RAN specifications.

#### 4.5.5 ProSe Proxy Function

ProSe Proxy Function enables support for UE to Home ProSe Function communication as defined in clause 4.4.1.1, where the Home ProSe Function is not located in the same network as the PDN GW for the PDN connection being used. Such proxy functions are needed when requirements on security are not met by signalling over Internet. Inter-PLMN signalling may be used in that case. Due to restrictions on the inter-PLMN network, the UE to Server traffic over the user plane may not be sent between networks directly. Only tunnelled server to server traffic may be sent between networks.

A roaming UE, which has a Local Breakout PDN Connection in the VPLMN, uses this access to reach a ProSe Function in the Home network. UE is not aware of the presence of a ProSe Proxy Function.

A ProSe Proxy implemented in the VPLMN on the SGi interface may be used to reach the ProSe Function located in the HPLMN. The ProSe Proxy Function forwards signalling traffic between the UE and the ProSe Function in the HPLMN.

## 4.6 Identifiers

### 4.6.1 Identifiers for EPC-level ProSe Discovery

The following identities are used for EPC-level ProSe Discovery: EPC ProSe User ID, Application Layer User ID and Application ID.

The ProSe Function is identified by an FQDN that the UE constructs using the HPLMN ID.

### 4.6.2 Identifiers for EPC support for WLAN direct discovery and communication

The following identifier is used in addition to those in clause 4.6.1 for EPC support for WLAN direct discovery and communication: WLAN Link Layer ID.

### 4.6.3 Identifiers for ProSe Direct Communication

#### 4.6.3.1 ProSe UE ID

This is a link layer identifier assigned by the ProSe Key Management Function as defined in TS 33.303 [29] that uniquely represents the UE in the context of one-to-many ProSe Direct Communication for this group. It is used as a source Layer-2 ID in all the packets the UE sends for one-to-many ProSe Direct Communication.

For support of multiple PDN Connections, the ProSe UE-to-Network Relay is assigned a different ProSe UE ID for each PDN Connection.

#### 4.6.3.2 ProSe Layer-2 Group ID

This is a link layer identifier that identifies the group in the context of one-to-many ProSe Direct Communication. It is used as a destination Layer-2 ID in all the packets the UE sends to this group for one-to-many ProSe Direct Communication.

### 4.6.4 Identifiers for ProSe Direct Discovery

#### 4.6.4.1 ProSe Application ID

For Open ProSe Discovery, (as described in 3GPP TS 22.278 [25]) the ProSe Application ID is called the Public ProSe Application ID. The geographic scope of the Public ProSe Application ID may be PLMN-specific, country specific or global.

Each Public ProSe Application ID is composed of the following parts:

- a. The ProSe Application ID Name is described in its entirety by a data structure characterized by different levels e.g., broad-level business category (Level 0) / business sub-category (Level 1) / business name (Level 2) / shop ID (Level 3). For the purpose of presentation, a ProSe Application ID Name is usually displayed as a string of labels in which the labels represent hierarchical levels.
- b. The PLMN ID that corresponds to the PLMN that assigned the ProSe Application ID Name.

NOTE: If the Public ProSe Application ID is country specific then the Mobile Network Code (MNC) of the PLMN ID is wild carded. If global, both the MCC and MNC are wild carded. The use of wild carded ProSe Application IDs is further explained in Annex B.

#### 4.6.4.2 ProSe Application Code

For the announcing UE, the ProSe Application Code is obtained from the HPLMN ProSe Function using the Announce Request procedure (see clauses 5.3.3.1 and 5.3.3.2). The ProSe Application Code is contained in the message that is



actually transmitted over the radio interface (on PC5) by a UE engaged in the ProSe Direct Discovery procedure (see clause 5.3) to "monitoring" UEs.

For the "monitoring" UE, Discovery Filter(s) to monitor the ProSe Application Code(s) over the radio interface (on PC5) are obtained from the HPLMN ProSe Function using the Monitor Request procedure (see clauses 5.3.3.4 and 5.3.3.5).

Each ProSe Application Code is composed of the following parts:

- a. A temporary identity that corresponds to the ProSe Application ID Name. Given the data structure associated with the Public ProSe Application ID, each ProSe Application ID can be associated with various temporary identities that contains as many identifiers as there are levels in the corresponding ProSe Application ID Name: this allows partial matching at the monitoring UE side using a ProSe Application Mask (see clause 4.6.4.2b) or a Discovery Filter, making more effective and flexible the filtering of the received temporary identity in a monitoring UE. See clause 4.6.4.2a..
- b. The PLMN ID of the ProSe Function that assigned the ProSe Application Code, i.e. Mobile Country Code (MCC) and Mobile Network Code (MNC).

NOTE 1: In this version of the specification the ProSe Application Code is always assigned by a HPLMN ProSe Function.

ProSe Application Code matching considers all components listed above. In ProSe Application Code matching, the "monitoring" UE shall consider it a full match, if both PLMN ID and temporary identity match with the corresponding contents of the Discovery Filter. A partial match is obtained if the PLMN ID matches fully and the temporary identity matches partially with the corresponding contents of the ProSe Application Mask (see clause 4.6.4.2b).

A ProSe Application Code is allocated per "announcing" UE and per application and has an associated validity timer that runs both in the ProSe Function and in the UE.

NOTE 2: In this Release of the specification it is not possible to revoke an assigned ProSe Application Code to announcing UE before the expiry of the validity timer.

In case of Open ProSe Discovery:

- when the "announcing" UE wants to announce something, it shall send a Discovery Request containing the Public ProSe Application ID to the ProSe Function, and the ProSe Function assigns a ProSe Application Code.
- when the "monitoring" UE wants to monitor something, it shall send a discovery request containing the full or a subset of the Public ProSe Application ID, e.g. it may provide 2 out of the n levels of the full Public ProSe Application ID.

NOTE 3: The ProSe Application ID Name data structure is not expected to change often.

#### 4.6.4.2a Discovery Filter

Discovery Filter consists of ProSe Application Codes, ProSe Application Masks and time to live (TTL). At least one of either ProSe Application Code or ProSe Application Mask shall be present. In addition, Discovery Filter shall contain one or more time to live (TTL). A TTL indicates for how long the related ProSe Application Code or ProSe Application Mask in the Discovery Filter is valid after it is received.

NOTE 1: In order for the ProSe Application Mask not to change often, the ProSe Application Mask does not extend to the last level of the corresponding Prose Application ID data structure (typically the leaf, i.e. the lowest level).

NOTE 2: The TTL related to a ProSe Application Code is "equal to" or "less than" the time remaining before the validity timer associated to that ProSe Application Code expires in the announcing UE. The TTL related to a ProSe Application Mask is set according to the policy of the HPLMN of the announcing UE.

A Discovery Filter is provided to a monitoring UE by its HPLMN ProSe Function. It is used by the monitoring UE to selectively match ProSe Application Codes received on the PC5 interface.

Discovery Filter without ProSe Application Mask can be used for identification of full match of the service indicated in ProSe Application Code. Discovery Filter with ProSe Application Mask allows partial matching of as many parts of ProSe Application Code as are contained in the ProSe Application Mask.

#### 4.6.4.2b ProSe Application Mask

A ProSe Application Mask is used for partial matching of ProSe Application Codes received on the PC5 interface. A ProSe Application Mask is contained in a Discovery Filter.

A ProSe Application Mask consists of one or more applicable parts of temporary identities of ProSe Application Codes to allow partial matching of ProSe Application Codes.

NOTE: The ProSe Application Mask is not expected to change often.

#### 4.6.4.3 Identifiers for ProSe UE-to-Network Relay discovery and selection

The following information may be used for ProSe UE-to-Network Relay discovery and selection:

- Message type identifier (e.g. identifying Model A or Model B discovery)
- ProSe Relay (UE) ID: link layer identifier that is used for direct communication and is associated with a PDN connection the ProSe UE-to-Network Relay has established.
- PLMN ID: this identifies the PLMN to which radio frequencies used on the link to the Remote UE belong. If these radio frequencies are shared between multiple PLMNs, or not allocated to any PLMN, then the choice of PLMN ID is configured by the HPLMN.
- ProSe Application Relay Code: parameter identifying connectivity the ProSe UE-to-Network Relay provides. (e.g. including APN information).
- Whether the UE can act as a relay.
- Status/maintenance flags (e.g. indicating whether the relay is temporarily without connectivity or battery running low so the Remote UEs can seek/reselect another Relay).

**Editor's note:** It is FFS if additional parameters are needed in order to protect the discovery message (e.g. restricted discovery).

---

## 5 Functional Description and Information Flow

### 5.1 Control and user plane stacks

#### 5.1.1 Control Plane

##### 5.1.1.1 General

The control plane stack consists of protocols for control and support of the user plane functions:

- controlling the configuration of the ProSe-enabled UE;
- controlling ProSe Direct Discovery;
- controlling the set-up of the connection between the Remote UE and the ProSe UE-to-Network Relay; and
- controlling the attributes of an established network access connection, such as activation of an IP address.

The following control planes are used in E-UTRAN mode.

5.1.1.2 UE - ProSe Function

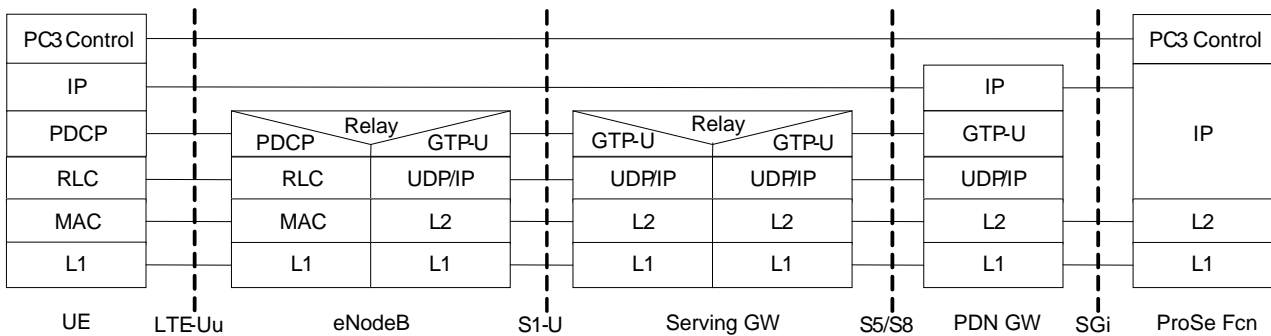

**Legend:**

- ProSe Control Signalling between UE and ProSe Function is carried over the user plane and is specified in TS 24.334 [24].

NOTE: PC3 may be realized with one or more protocols.

**Figure 5.1.1.2-1: Control Plane for PC3 Interface**

5.1.1.3 HSS - ProSe Function

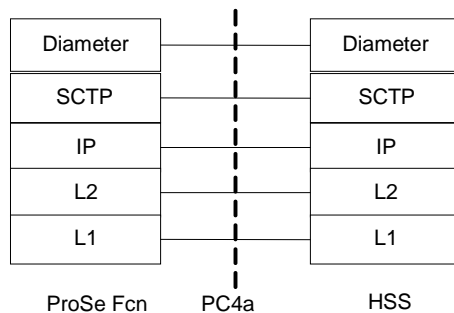

**Legend:**

- Diameter: This protocol supports the transfer of subscription and authentication data for authenticating/authorizing user access to ProSe between ProSe Function and HSS (PC4a). Diameter is defined in RFC 3588 [18].
- Stream Control Transmission Protocol (SCTP): This protocol transfers signalling messages. SCTP is defined in RFC 4960 [19].
- PC4a between the ProSe Function and the HSS is specified in TS 29.344 [22].

**Figure 5.1.1.3-1: Control Plane for PC4a Interface**

5.1.1.4 SLP - ProSe Function

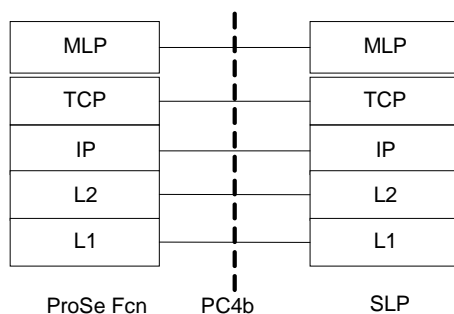

**Legend:**

- Mobile Location Protocol (MLP) is specified in OMA LIF MLP [20].

**Figure 5.1.1.4-1: Control Plane for PC4b Interface**

5.1.1.5 UE - UE

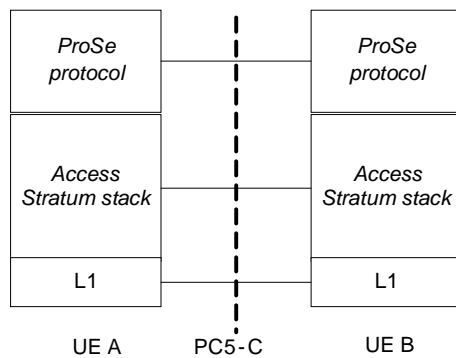

**Legend:**

- **PC5-C:** The radio protocols of E-UTRA between UE A and UE B are specified in TS 36.300 [17].
- The "ProSe protocol" is used for handling ProSe Direct Discovery and ProSe UE-to-Network Relay discovery and is specified in TS 24.334 [24].

*Editor's note: ProSe protocol to be defined by RAN and CT WGs.*

*Editor's note: Access Stratum stack to be reviewed and finally decided in RAN WGs,*

**Figure 5.1.1.5-1: Control Plane PC5 Interface**

5.1.1.6 ProSe Function - ProSe Function

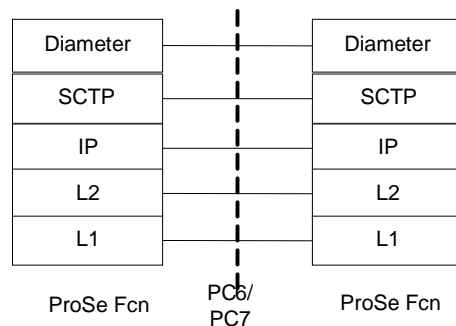

**Legend:**

- PC6 is an inter-PLMN interface between the ProSe Functions in different PLMNs (EPC-level ProSe Discovery) and between the ProSe function in the HPLMN and the ProSe function in Local PLMN (ProSe Direct Discovery). PC7 is a roaming interface between the ProSe function in the HPLMN and the ProSe function in VPLMN. PC6 and PC7 are specified in TS 29.345 [23]
- Diameter: This protocol supports the transfer of subscriber location related information between ProSe Functions (PC6/PC7). Diameter is defined in RFC 3588 [18].
- Stream Control Transmission Protocol (SCTP): This protocol transfers signalling messages. SCTP is defined in RFC 4960 [19].

**Figure 5.1.1.6-1: Control Plane for PC6 and PC7 interface**

5.1.1.7 ProSe Function - ProSe Application Server

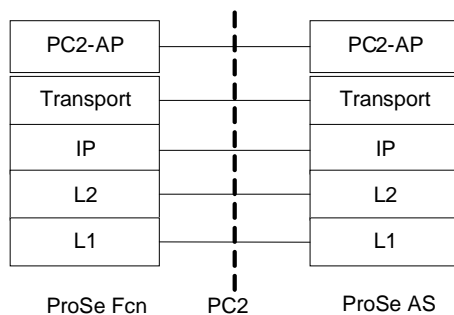

**Legend:**

- PC2-AP is the PC2 Application Protocol and is specified in TS 29.343 [21]

**Figure 5.1.1.7-1: Control Plane for PC2 interface**

5.1.2 User Plane

5.1.2.1 UE - UE

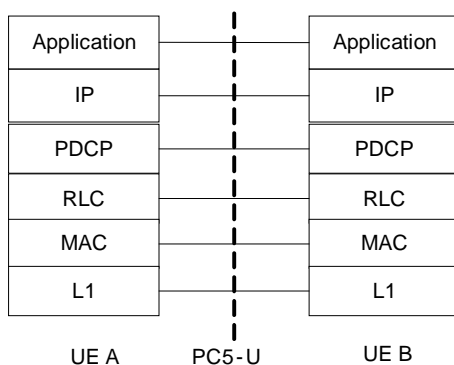

**Legend:**

- **PC5-U:** The radio protocols of E-UTRA between UE A and UE B are specified in TS 36.300 [17] .

*Editor's note: Access Stratum stack to be reviewed and finally decided in RAN WGs.*

**Figure 5.1.2.1-1: User Plane for PC5 interface**

### 5.1.2.2 UE - UE-to-Network Relay

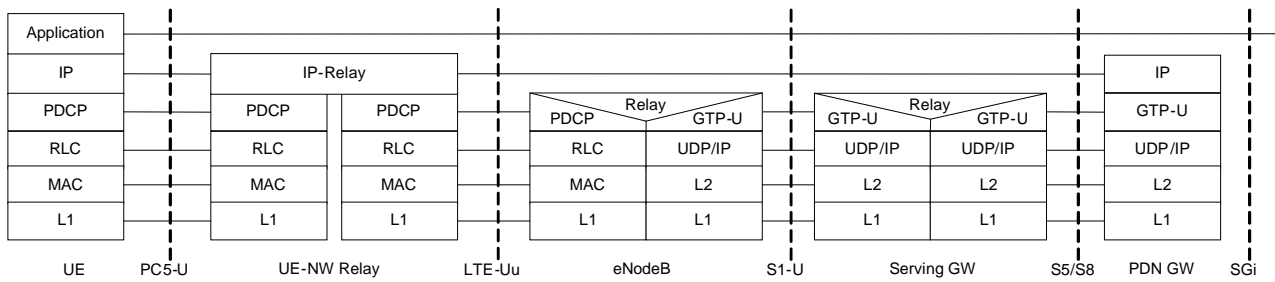

**Legend:**

- GPRS Tunnelling Protocol for the user plane (GTP-U): This protocol tunnels user data between eNodeB and the S-GW as well as between the S-GW and the P-GW in the backbone network. GTP shall encapsulate all end user IP packets.
- MME controls the user plane tunnel establishment and establishes User Plane Bearers between eNodeB and S-GW.
- UDP/IP: These are the backbone network protocols used for routing user data and control signalling.
- LTE-Uu: The radio protocols of E-UTRAN between the UE and the eNodeB are specified in TS 36.300 [17].
- PC5-U: The radio protocols of E-UTRAN between the UE and the UE-to-Network Relay are specified in TS 36.344 [24].

*Editor's Note: Access Stratum stack to be reviewed and finally decided in RAN WGs.*

**Figure 5.1.2.2-1: User Plane for UE-to-Network Relay**

## 5.2 Service authorisation and revocation for ProSe Direct Discovery and ProSe Direct Communication

### 5.2.1 Service authorisation procedures

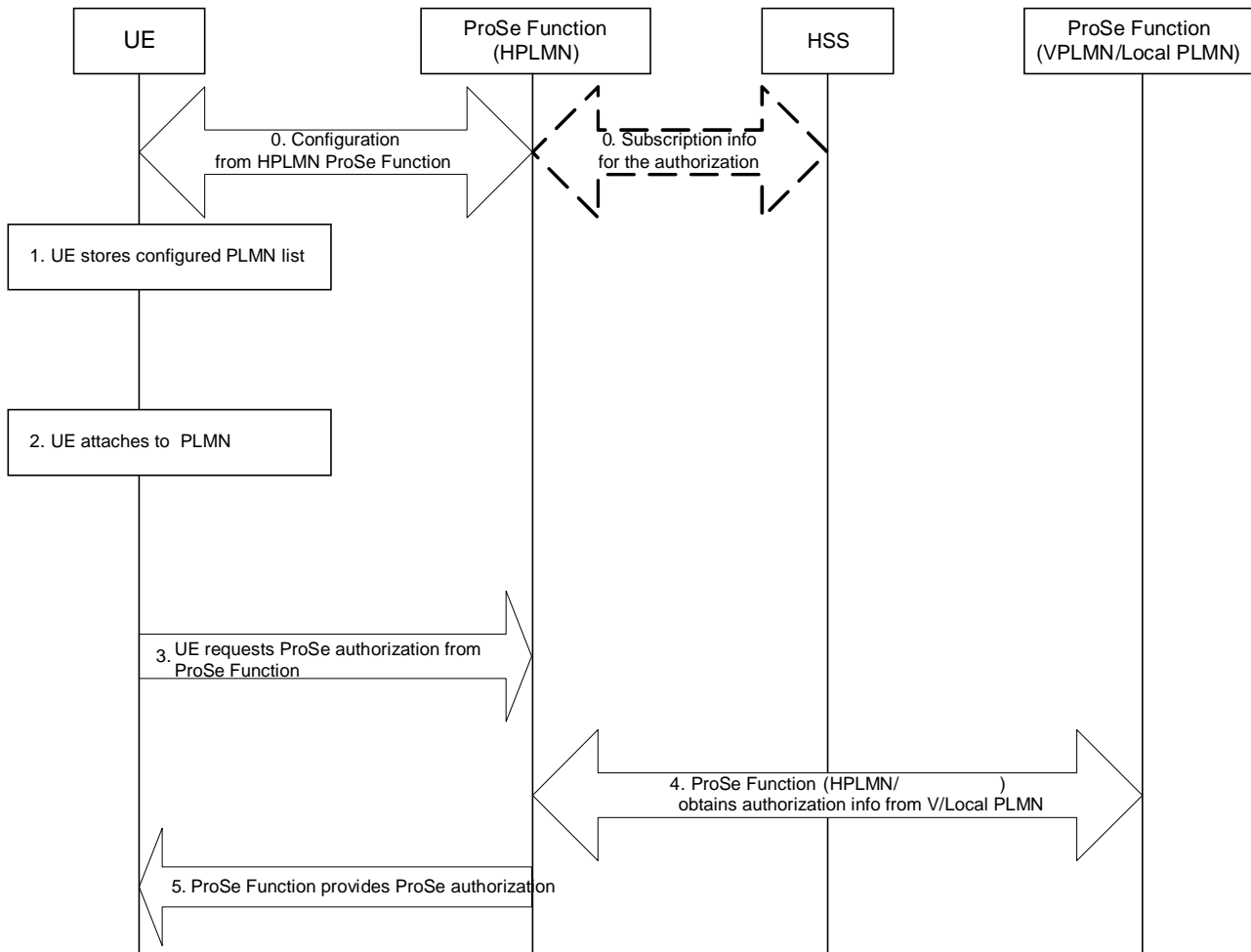

**Figure 5.2-1: Service authorisation for ProSe Direct Discovery or ProSe Direct Communication or both**

The UE gets the service authorisation for ProSe Direct Discovery or ProSe Direct Communication or both, with a given validity time, from the ProSe Functions of HPLMN.

The service authorisation procedure is executed:

- before starting the setup of ProSe Direct Discovery or ProSe Direct Communication, or
- when the UE already engaged in a ProSe Direct Discovery or ProSe Direct Communication changes its registered PLMN, or
- when the service authorisation is no longer valid.

The authorisation is happening using "over IP" mechanisms and only IP connectivity is required to allow the UE to access this ProSe Function.

In this signalling flow the following steps are performed:

- Step 0-1: HPLMN pre-configures UE with PLMN list that support ProSe Direct Discovery or ProSe Direct Communication or both. If there is no associated UE context, the ProSe Function gets the subscription information for ProSe Direct Discovery and/or ProSe Direct Communication from HSS.

- Step 2: UE camps in the serving PLMN.
- Step 3: The UE requests authorisation for Direct Discovery or Direct Communication or both for some VPLMN or for Direct Discovery (as a "monitoring UE" only) for some Local PLMNs from the ProSe Function in HPLMN. The UE may request a list of PLMNs to be downloaded from HPLMN ProSe Function depending on the location e.g. HPLMN or VPLMN.
- Step 4: The ProSe Function in HPLMN obtains authorization info from Local PLMN or VPLMN and merges with own policy.
- Step 5: The ProSe Function in HPLMN provides authorisation info to UE. The authorisation info provided to the UE applies to the serving PLMN, to PLMNs explicitly requested by the UE in step 3 and to PLMNs determined by the HPLMN as Local PLMNs (e.g. based on the Serving PLMN) to be available to the UE. The UE stores the authorisation information obtained from this ProSe Function in a secure way. If needed at any point the authorization can be revoked by the ProSe Function in Local PLMN or VPLMN or ProSe Function in the HPLMN.

## 5.2.2 Service authorization update procedures

### 5.2.2.1 General

The allowed PLMN for ProSe direct service can be updated at any point by the HSS or the ProSe function. And the ProSe function can be the ProSe function in HPLMN, in VPLMN or in Local PLMN.

The update of the allowed PLMN for ProSe direct service applies to ProSe Direct Discovery or ProSe Direct Communication or both.

NOTE: The addition of the PLMN into allowed PLMN list for ProSe direct service is triggered by HSS.

### 5.2.2.2 HSS triggered ProSe direct Service authorization update

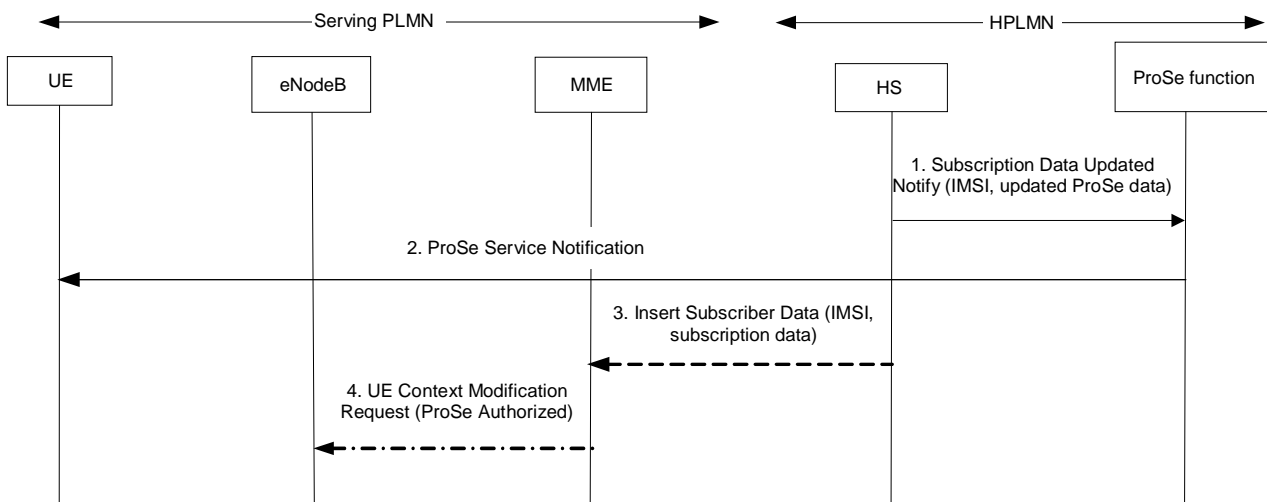

Figure 5.2.2.2-1: HSS triggered ProSe direct services authorization update

NOTE: Steps 3, 4 can be executed at the same time as step 2.

1. The ProSe related subscription data is updated, e.g. the authorization for ProSe direct discovery service is updated. The HSS sends a Subscription Data Updated Notify (IMSI, updated ProSe data) message to the ProSe Function in HPLMN. The Subscription Data Updated Notify message may add or remove the PLMNs from the allowed PLMN list for ProSe direct service. The updated ProSe data includes the indication and the PLMN ID. The PLMN ID is optional. If it is not included, it denotes the authorization for ProSe direct service (discovery or communication or both) identified by the indication is to be updated on all PLMNs. Otherwise only the authorization for ProSe direct service in the indicated PLMN is to be updated. Upon receiving the message, the ProSe Function in HPLMN updates the associated ProSe UE context if it has been stored before.



2. The UE get the updated authorisation for ProSe direct service via the ProSe Service Notification message immediately or waits to the next time communication with the ProSe function in HPLMN per operator's policy.
3. If the authorization for ProSe direct service includes the change to the PLMN which UE is registered, e.g. remove the PLMN UE registered from allowed ProSe direct discovery PLMN list, and the ProSe direct service to be updated includes ProSe direct discovery announcing or ProSe direct communication, the HSS notifies the updated ProSe subscription data to the MME via the Insert Subscriber Data message. If only the authorization for ProSe direct discovery monitoring is to be updated, the notification to the MME is not need. The MME updates the stored UE context.
4. If the S1 bearer is established, the MME sends the updated UE ProSe context to eNodeB via the UE Context Modification Request (ProSe Authorized) message. The eNodeB take the following action based on the updated "ProSe Authorized" indication.

5.2.2.3 ProSe function triggered ProSe Direct Service revocation (non-roaming)

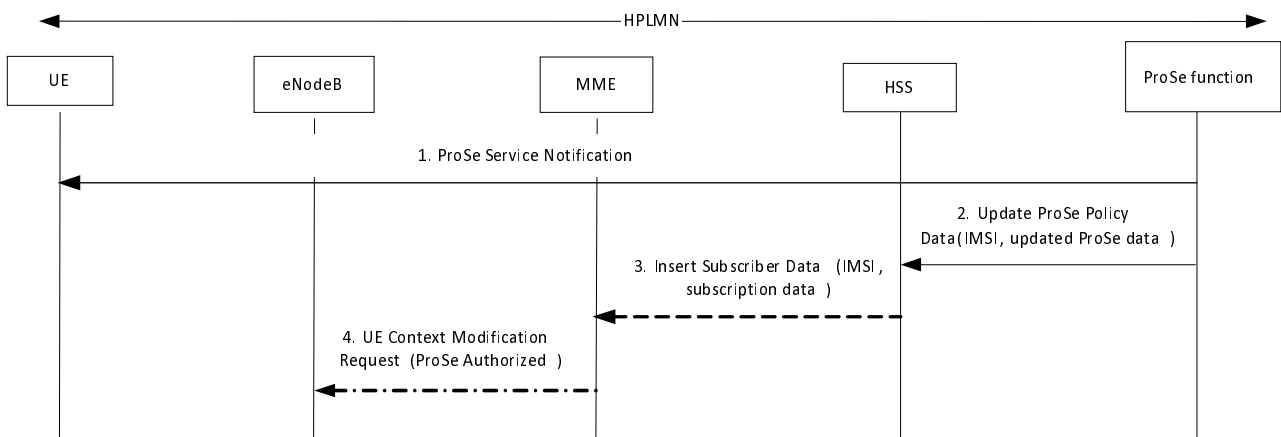

Figure 5.2.2.3-1: ProSe Function triggered ProSe direct services revocation (non-roaming)

NOTE: Steps 2, 3, 4 can be executed at the same time as step 1.

1. The HPLMN ProSe Function decides to revoke the authorization for ProSe direct service, e.g. ProSe Direct Discovery service is revoked on one PLMN. The UE get the updated authorization for ProSe direct service via the ProSe Service Notification message immediately or waits to the next time communication with the ProSe function in HPLMN per operator's policy.
2. The ProSe Function notifies the HSS to change the subscription data by sending an Update ProSe Policy Data (IMSI, updated ProSe data) message. The updated ProSe data includes the indication and the PLMN ID. The combination of the indication and the PLMN ID denotes the authorization for ProSe direct service (discovery or communication or both) identified by the indication is to be revoked on the indicated PLMN. Upon receiving the message, the HSS updates the ProSe subscription data.

The description of steps 3-4 are the same as steps 3-4 in clause 5.2.2.2.

### 5.2.2.4 ProSe function triggered ProSe Direct Service revocation (roaming)

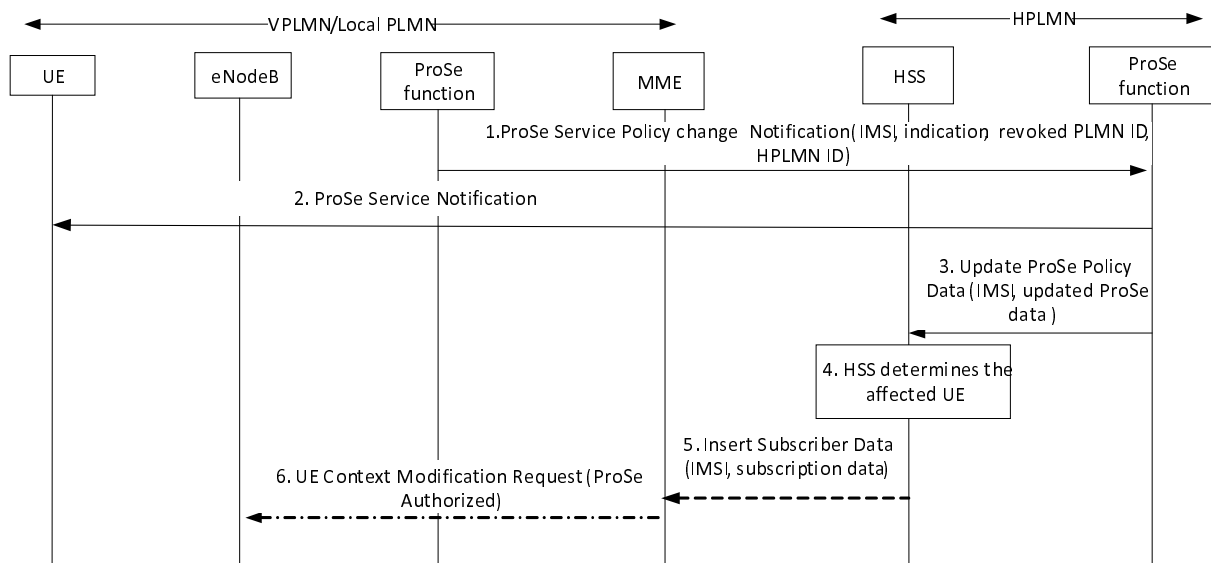

**Figure 5.2.2.4-1: ProSe Function triggered ProSe direct services revocation(roaming)**

NOTE: Steps 3, 4, 5, 6 can be executed at the same time as step 2.

1. The VPLMN or Local PLMN ProSe Function decides to revoke the authorization for ProSe direct service, e.g. ProSe direct discovery service is revoked for the inbound roamer. The VPLMN or Local PLMN ProSe Function sends a ProSe Service Policy change Notification (IMSI, indication, revoked PLMN ID, HPLMN ID) message to HPLMN ProSe Function. The IMSI is optional, e.g. the revocation of ProSe direct discovery service from Local PLMN ProSe Function. If it is not included in the message, the ProSe direct service to be revoked aims to all the UE from the indicated HPLMN ID. The combination of the indication and the revoked PLMN ID denotes the authorization for ProSe direct service (discovery or communication or both) identified by the indication is to be revoked on the indicated PLMN.
2. The UE get the updated authorization for ProSe direct service via the ProSe Service Notification message immediately or waits to the next time communication with the ProSe function in HPLMN per operator's policy.
3. The HPLMN ProSe Function notifies the HSS to change the subscription data by sending an Update ProSe Policy Data (IMSI, updated ProSe data) message. The IMSI is included if it is received in step 1. The updated ProSe data includes the indication and the Revoked PLMN ID received in step 1.
4. If the IMSI is not received, the HSS determines the affected UE based on the revoked PLMN ID, i.e. the authorization of UE's ProSe direct service includes the revoked PLMN ID, and updates the ProSe subscription data.

For each affected UE the HSS trigger the update procedure as the steps 5-6. The description of steps 5-6 are the same as steps 3-4 in clause 5.2.2.2.

## 5.3 ProSe Direct Discovery

### 5.3.1 General

#### 5.3.1.1 Overview

ProSe Direct Discovery is defined as the process that detects and identifies another UE in proximity using E-UTRA direct radio signals.

There are two types of ProSe Direct Discovery: open and restricted. Open is the case where there is no explicit permission that is needed from the UE being discovered, whereas restricted discovery only takes place with explicit permission from the UE that is being discovered.

ProSe Direct Discovery can be a standalone service enabler that could for example use information from the discovered UE for certain applications in the UE that are permitted to use this information e.g. "find a taxi nearby", "find me a coffee shop". Additionally depending on the information obtained ProSe Direct Discovery can be used for subsequent actions e.g. to initiate ProSe Direct Communication.

The UE can act as "announcing UE" only in the band designated by the serving PLMN but may act as a "monitoring" UE also in the resources of the serving PLMN and Local PLMNs.

ProSe-enabled non-Public Safety UEs which have obtained authorization to participate in ProSe Direct Discovery procedures shall not continue in participating in ProSe Direct Discovery procedures as soon as they detect loss of E-UTRA coverage in the serving PLMN.

### 5.3.1.2 ProSe Direct Discovery Models

The following models for ProSe Direct Discovery exist:

#### **Model A ("I am here")**

This model defines two roles for the ProSe-enabled UEs that are participating in ProSe Direct Discovery.

- **Announcing UE:** The UE announces certain information that could be used by UEs in proximity that have permission to discover.
- **Monitoring UE:** The UE that monitors certain information of interest in proximity of announcing UEs.

In this model the announcing UE broadcasts discovery messages at pre-defined discovery intervals and the monitoring UEs that are interested in these messages read them and process them.

NOTE: This model is equivalent to "I am here" since the announcing UE would broadcast information about itself e.g. its ProSe Application Code in the discovery message.

#### **Model B ("who is there?" / "are you there?")**

This model defines two roles for the ProSe-enabled UEs that are participating in ProSe Direct Discovery.

- **Discoverer UE:** The UE transmits a request containing certain information about what it is interested to discover.
- **Discoveree UE:** The UE that receives the request message can respond with some information related to the discoverer's request.

It is equivalent to "who is there/are you there" since the discoverer UE sends information about other UEs that would like to receive responses from, e.g. the information can be about a ProSe Application Identity corresponding to a group and the members of the group can respond.

### 5.3.2 Overall procedure for ProSe Direct Discovery (Model A)

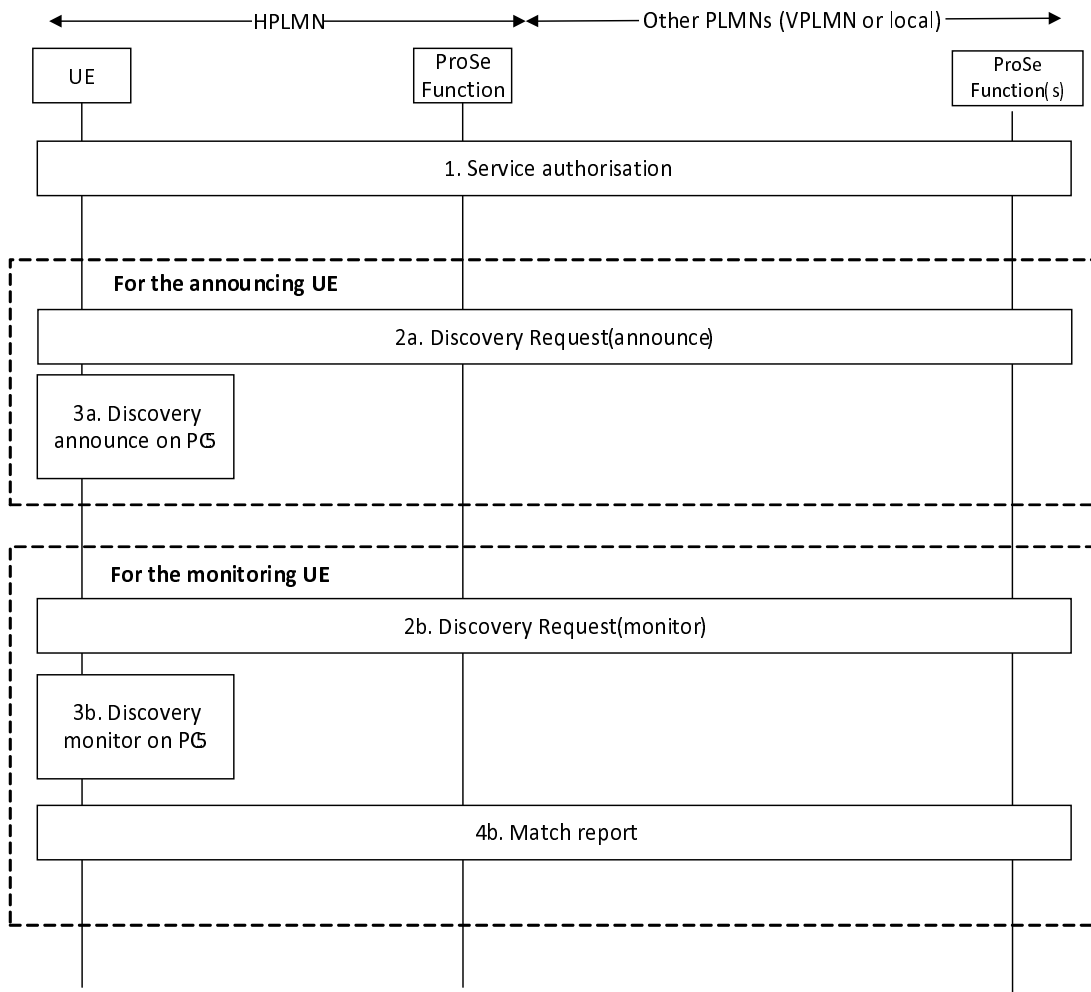

**Figure 5.3.2-1: Overall procedure for ProSe Direct Discovery**

This procedure is only applied for open ProSe discovery when the ProSe enabled UE is served by E-UTRAN.

1. Service authorisation for ProSe direct services is performed for ProSe Direct Discovery as defined in clauses 5.2, and 4.5.1.

If the UE is authorised to announce:

- 2a. When the UE is triggered to announce then it sends a discovery request for announcing to the ProSe Function in HPLMN as defined in clauses 5.3.3.2 and 5.3.3.3.
- 3a. If the request is successful and is provided with ProSe Application Code then it starts announcing on PC5 interface.

NOTE 1: More details on the Access Stratum protocol of this step are provided in RAN specifications.

If the UE is authorised to monitor:

- 2b. When the UE is triggered to monitor, it sends a discovery request for monitoring to the ProSe Function as defined in clauses 5.3.3.4 and 5.3.3.5.
- 3b. If the request is successful and the UE is provided with a Discovery Filter consisting of ProSe Application Code(s) and/or ProSe Application Mask(s) it starts monitoring for these ProSe Application Codes on the PC5 interface.

NOTE 2: More details on the Access Stratum protocol of this step are provided in RAN specifications.

- 4b. When the UE detects that one or more ProSe Application Code(s) that match the filter (see sub-clause 4.6.4.2), it reports the ProSe Application Code(s) to the ProSe Function as defined in clause 5.3.4.

Non roaming direct discovery procedures cover the case where both the "announcing UE" and "monitoring UE" are served by their respective HPLMN. Roaming direct discovery procedures cover the other cases.

### 5.3.3 Discovery Request

#### 5.3.3.1 General

The Discovery Request is sent by the "announcing UE" or "monitoring UE" in order to be authorised to access the discovery resources and perform ProSe Direct Discovery.

#### 5.3.3.2 Announce request (non-roaming)

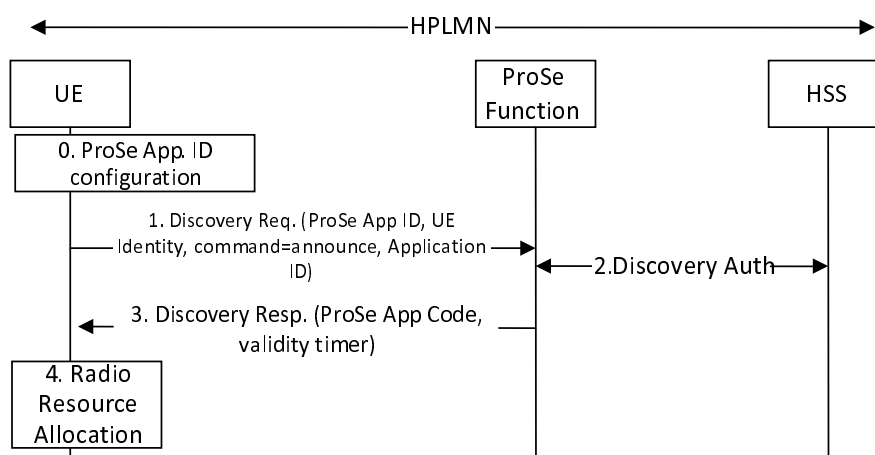

**Figure 5.3.3.2-1: Announce request procedure (non-roaming)**

0. The UE is configured with the data structure of the ProSe Application IDs corresponding to HPLMN. This step is performed using mechanisms that are out of scope of 3GPP.
1. If the UE is authorised to announce in HPLMN and is triggered to announce, it shall establish a secure connection with the ProSe Function and it shall send a Discovery Request (ProSe Application ID, UE Identity, announce command, Application ID) message for announcing. The ProSe Application ID indicates what the UE is interested to announce. The UE Identity is set to e.g. IMSI. The Application ID represents a unique identifier of the UE application that has triggered the transmission of the Discovery Request message. This request is always sent to the ProSe Function in HPLMN.

**NOTE:** Whether for the Application ID, the operating system specific identity would suffice or a namespace needs to be defined by 3GPP that will be common across all operating systems is not further specified in this specification.

2. The ProSe Function checks for the authorization of the application represented by the Application ID. If there is no associated UE context, the ProSe Function shall check with HSS the authorisation for discovery and create a new context for this UE that contains the subscription parameters for this UE for the duration of the validity timer. The HSS provides the MSISDN of the UE. If the UE does not issue a new announce request within the duration of the validity timer the ProSe Function shall remove the entry related to the requested ProSe Application ID from the UE context.
3. If the Discovery Request is authorised, then the ProSe Function shall respond with a Discovery Response (ProSe Application Code, validity timer) message. The ProSe Application Code is provided by the ProSe Function and corresponds to the ProSe Application ID that was contained in the Discovery Request. The validity timer indicates for how long this ProSe Application Code is going to be valid. The UE will be authorised to announce this ProSe Application Code for the duration of validity timer and if it remains in the HPLMN. When the validity timer expires or the UE changes its registered PLMN the UE needs to request a new ProSe Application Code.

- The UE may start announcing the provided ProSe Application Code in HPLMN, using the radio resources authorised and configured by E-UTRAN to be used for ProSe as defined in RAN specifications.

### 5.3.3.3 Announce request (roaming)

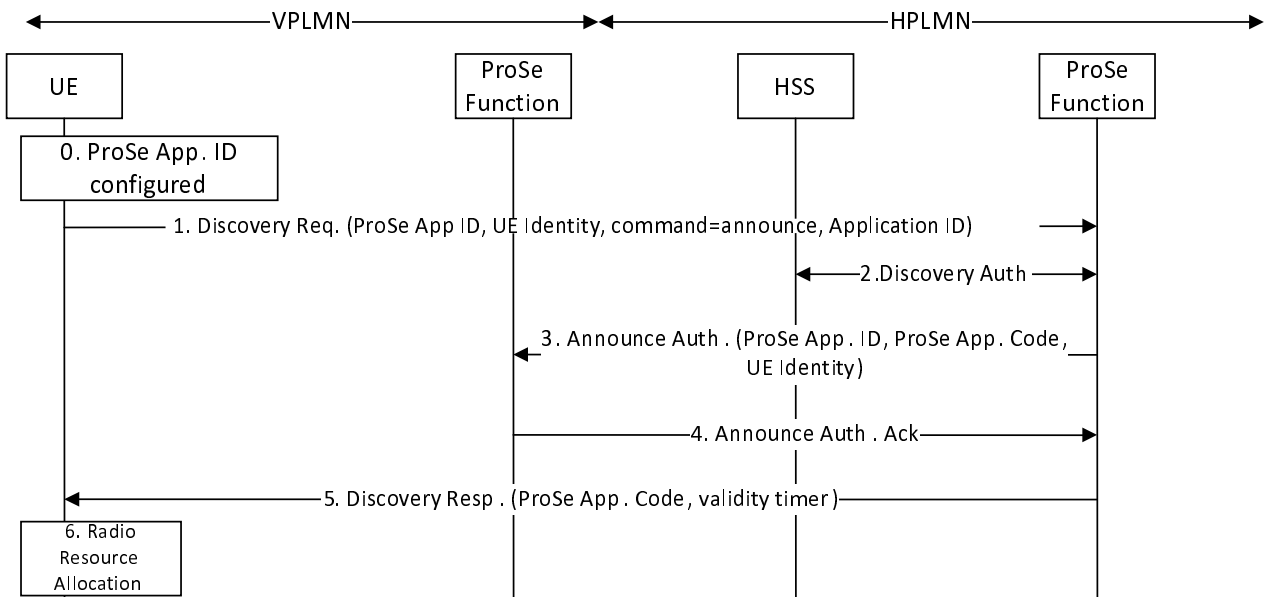

**Figure 5.3.3.3-1: Announce request procedure (roaming)**

The UE is only allowed to announce in the bands signalled from VPLMN.

- The UE is configured with the data structure of the ProSe Application IDs corresponding to HPLMN. This step is performed using mechanisms that are out of scope of 3GPP.
- If the UE is authorised to announce in VPLMN and is triggered to announce, it shall establish a secure connection with the ProSe Function in HPLMN and it shall then send a Discovery Request (ProSe Application ID, UE Identity, announce command, Application ID) message for announcing. The ProSe Application ID indicates what the UE is interested to announce. The UE Identity is set to e.g. IMSI. The Application ID represents a unique identifier of the UE application that has triggered the transmission of the Discovery Request message. This request is always sent by the UE to the ProSe Function in HPLMN.
- The ProSe Function checks for the authorization of the application represented by the Application ID. If there is no associated UE context, the ProSe Function shall check with HSS the authorisation for discovery and, if necessary, create a new context for this UE that contains the subscription parameters for this UE for the duration of the validity timer. The HSS provides the MSISDN of the UE. The HSS also provides the VPLMN ID of where the UE is registered. If the UE does not issue a new announce request within the duration of the validity timer the ProSe Function shall remove the entry related to the requested ProSe Application ID from the UE context.
- If the Discovery Request is authorised then the HPLMN ProSe Function shall inform the ProSe Function in VPLMN with the Announce Authorisation (ProSe Application ID, ProSe Application Code, UE Identity) message. The ProSe Application ID corresponds to the request from the UE, whereas the ProSe Application Code indicates the assigned code for this request. The request also includes the UE identity information e.g. IMSI or MSISDN in order to allow the ProSe Function in VPLMN to perform charging.
- The ProSe Function in VPLMN authorizes the UE to perform ProSe Direct Discovery announcing.
- The ProSe Function in HPLMN shall respond to the UE with a Discovery Response (ProSe Application Code, validity timer) message. ProSe Application Code is provided by the ProSe Function in HPLMN and corresponds to the ProSe Application ID that was contained in the Discovery Request from the UE. The validity timer shall indicate for how long this ProSe Application Code is going to be valid. The UE will be authorised to announce this ProSe Application Code for the duration of validity timer and if it remains in the same PLMN.

6. The UE may start announcing the provided ProSe Application Code in the VPLMN, using the radio resources authorised and configured by E-UTRAN to be used for ProSe as defined in RAN specifications.

#### 5.3.3.4 Monitor request (non-roaming)

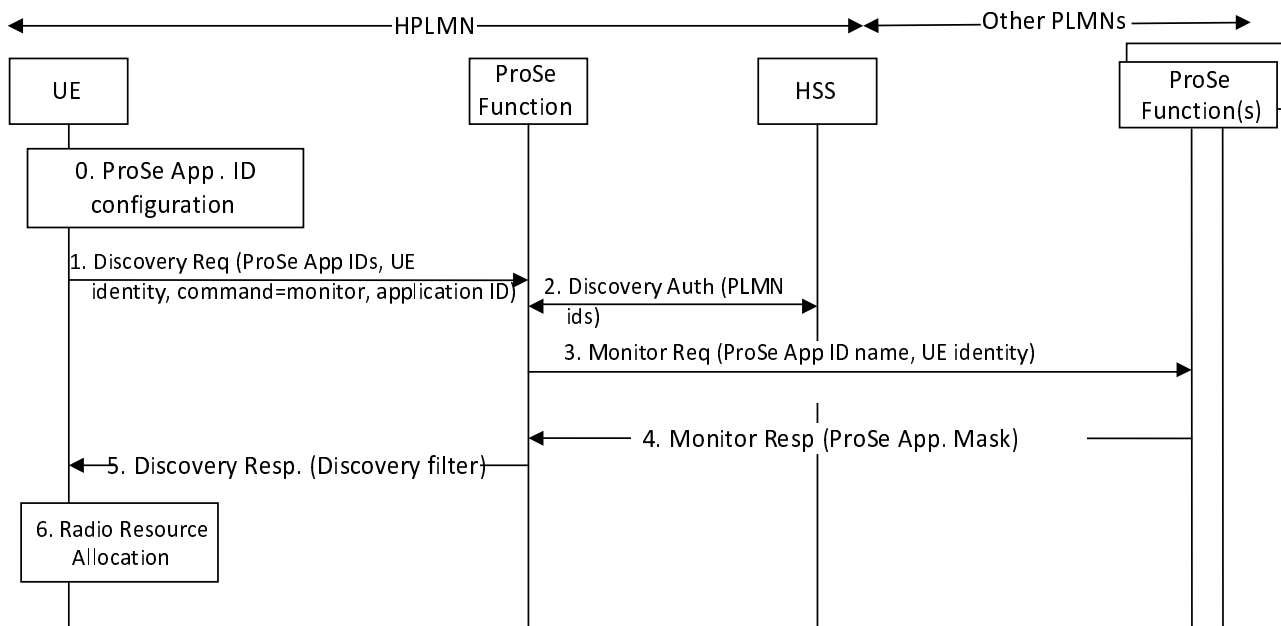

**Figure 5.3.3.4-1: Monitor request procedure (non-roaming)**

0. The UE is configured with the data structure of the ProSe Application IDs corresponding to PLMNs the UE is authorised to monitor. This step is performed using mechanisms that are out of scope of 3GPP.
1. If the UE is authorised to monitor in at least one PLMN and is interested to monitor certain ProSe Application ID(s), it shall establish a secure connection with ProSe Function in the HPLMN to which it shall then send a Discovery Request (ProSe Application ID(s), UE Identity, monitor command, Application ID) message for monitoring. The ProSe Application ID(s) indicate what the UE is interested to monitor and they consist a subset of the data structure of the PLMN. The UE Identity is set to e.g. IMSI. The Application ID represents a unique identifier of the application that has triggered the transmission of the Discovery Request message. This request is always sent to the ProSe Function in HPLMN.
2. The ProSe Function checks for the authorization of the application represented by the Application ID. If there is no associated UE context, the ProSe Function shall check with HSS the authorisation for discovery and create a new context for this UE that contains the subscription parameters for this UE for the duration the Discovery Filters will be valid. The HSS provides the MSISDN of the UE. The authorisation information also contains the PLMNs that this UE is allowed to perform discovery. If the UE does not issue a new monitor request within the duration the Discovery Filters are valid the ProSe Function shall remove the entry related to the requested ProSe Application ID from the UE context.

If the Discovery Request is authorised, and the ProSe Application ID sent by the UE in step 1 indicates another Local PLMN then steps 3-6 are executed, otherwise (i.e. the ProSe Application ID indicates HPLMN) only steps 5-6 are executed:

3. When the ProSe Application ID has PLMN-specific scope then the ProSe Function in HPLMN shall contact if needed) other PLMNs that are indicated by the ProSe Application ID(s) sent by the UE, in order to resolve the corresponding ProSe Application ID Name(s) to ProSe Application Code(s) and/or a ProSe Application Mask. The request shall also include the UE identity information e.g. IMSI or MSISDN in order to allow the ProSe Function in Local PLMN to perform charging.
4. If the ProSe Function of the Local PLMN stores valid ProSe Application Code(s) corresponding to the requested ProSe Application ID Name(s), then the ProSe Function of the Local PLMN returns the related ProSe Application Code(s) and/or ProSe Application Mask(s) and the corresponding TTL for each.

- The ProSe Function in the HPLMN shall respond with a Discovery Response (Discovery Filter(s), Filter ID) message. The TTL(s) in the Discovery Filter(s) indicates for how long the Discovery Filter(s) is going to be valid.

NOTE 1: The UE can randomize the request for assignment of new Discovery Filter in order to guard against a peak of Discovery Requests when the TTL expires.

NOTE 2: To allow a change of the announced ProSe Application Code without interrupting the discovery procedure, two Discovery Filters for the same ProSe Application ID can be provided to the UE (as the monitoring UE would have Discovery Filters for both the ProSe Application Code which is currently in use by the announcing UE as well as the ProSe Application Code which will replace the current one). Alternatively a ProSe Application Mask, which is able to match both ProSe Application Codes, can be provided.

- The UE may start monitoring using the Discovery Filter(s) in the radio resources that are authorized and configured by the PLMN(s) to be used for ProSe as defined in RAN specifications.

### 5.3.3.5 Monitor request (roaming)

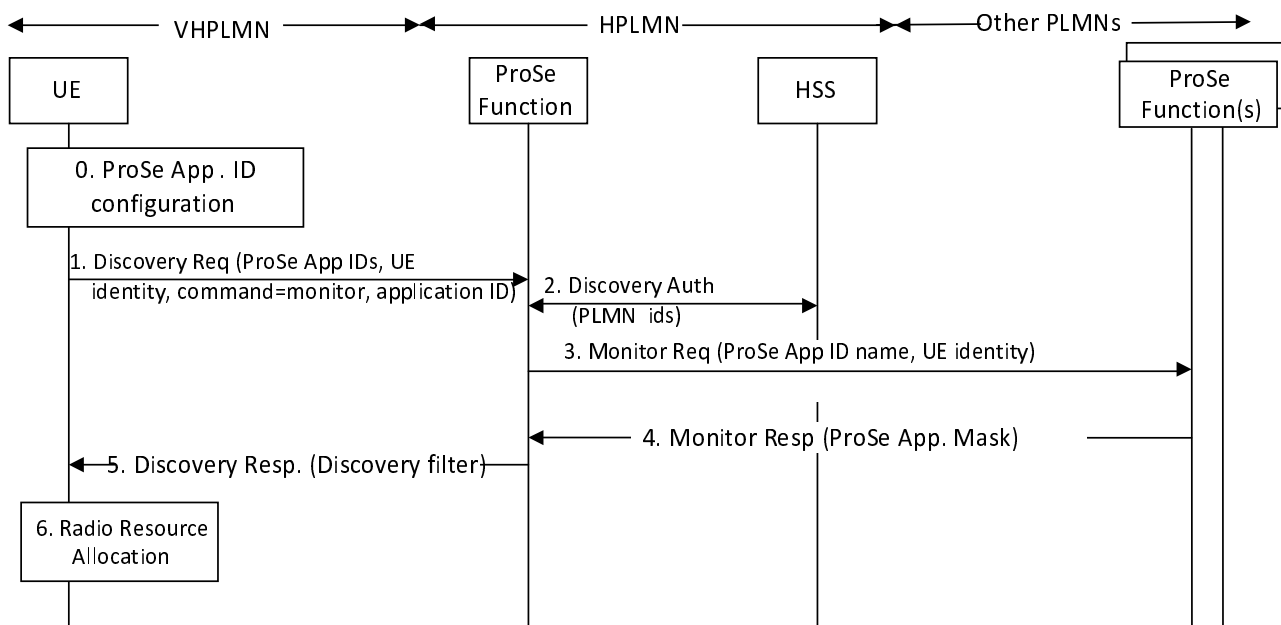

**Figure 5.3.3.5-1: Monitor request procedure (roaming)**

- The UE is configured with the data structure of the ProSe Application IDs corresponding to PLMNs the UE is authorised to monitor. This step is performed using mechanisms out of scope of 3GPP.
- If the UE is authorised to monitor in at least one PLMN and is interested to monitor certain ProSe Application ID(s), it shall establish a secure connection with the ProSe Function in HPLMN and it shall send a Discovery Request (ProSe Application ID(s), UE Identity, monitor command, Application ID) message for monitoring. The ProSe Application ID(s) indicate what the UE is interested to monitor and they consist of a subset of the data structure of the PLMN. The UE Identity is set to e.g. IMSI. The Application ID represents a unique identifier of the application that has triggered the transmission of the Discovery Request message. This request is always sent to the ProSe Function in HPLMN.
- The ProSe Function checks for the authorization of the application represented by the Application ID. If there is no associated UE context, the ProSe Function shall check with HSS the authorisation for discovery and, if necessary, create a new context for this UE that contains the subscription parameters for this UE for the duration the Discovery Filters will be valid. The authorisation information also contains the PLMNs that this UE is allowed to perform discovery. The HSS provides also the VPLMN ID where the UE is registered. The HSS provides the MSISDN of the UE. If the UE does not issue a new monitor request within the duration the Discovery Filters are valid the ProSe Function shall remove the entry related to the requested ProSe Application ID from the UE context.



If the Discovery Request is authorised, and the ProSe Application ID sent by the UE in step 1 indicates another PLMN and not the HPLMN, then steps 3-6 are executed, otherwise (i.e. the ProSe Application ID indicates HPLMN) only steps 5-6 are executed:

3. When the ProSe Application ID has PLMN-specific scope then the ProSe Function in HPLMN shall contact (if needed) other PLMNs that are indicated by the ProSe Application ID(s) sent by the UE, in order to resolve the corresponding ProSe Application ID Name(s) to ProSe Application Code(s) and/or a ProSe Application Mask. The request shall also include the UE identity information e.g. IMSI or MSISDN in order to allow the ProSe Function in Local PLMN to perform charging.
4. If the ProSe Function of the other PLMN stores valid ProSe Application Code(s) corresponding to the requested ProSe Application ID Name(s), then the ProSe Function of the VPLMN/Local PLMN returns the related ProSe Application Code(s) and/or ProSe Application Mask(s) and the corresponding TTL for each. Based on the UE context in the ProSe Function of the VPLMN/Local PLMN, it also includes the PLMN ID of the PLMN that the "announcing UE" is registered (if roaming) for the ProSe Function in HPLMN of the monitoring UE to store in the associated UE context.
5. The ProSe Function in the HPLMN responds with a Discovery Response (Discovery Filter(s), Filter ID) message. The TTL(s) in the Discovery Filter(s) indicate for how long the Discovery Filter(s) are going to be valid.

NOTE 1: The UE can randomize the request for assignment of new Discovery Filter in order to guard against a peak of Discovery Requests when the TTL expires.

NOTE 2: To allow a change of the announced ProSe Application Code without interrupting the discovery procedure, two Discovery Filters for the same ProSe Application ID can be provided to the UE (as the monitoring UE would have Discovery Filters for both the ProSe Application Code which is currently in use by the announcing UE as well as the ProSe Application Code which will replace the current one). Alternatively a ProSe Application Mask, which is able to match both ProSe Application Codes, can be provided.

6. The UE may start monitoring using the Discovery Filter(s) in the radio resources that are authorized and configured by the PLMN(s) to be used for ProSe as defined in RAN specifications.

## 5.3.4 Discovery reporting

### 5.3.4.1 Match report (non-roaming)

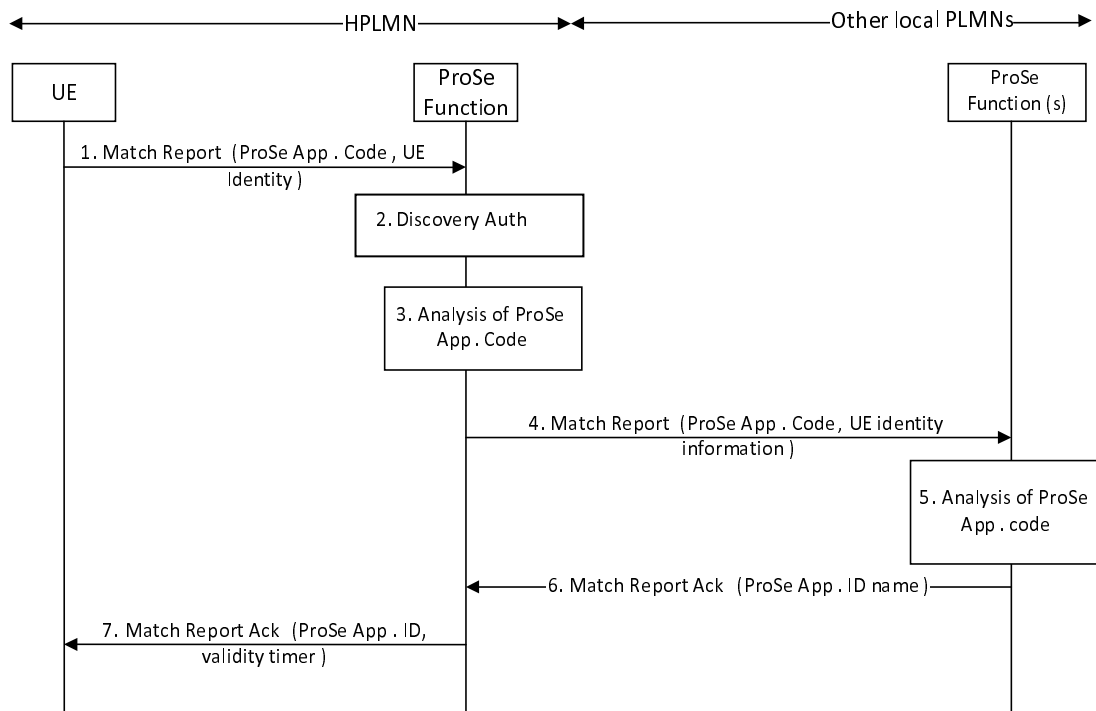

**Figure 5.3.4.1-1: Match report procedure (non-roaming)**

1. If the UE finds ProSe Application Code(s) that matches the Discovery Filters and does not have ProSe Application ID(s) already locally stored that correspond to this ProSe Application Code(s), it shall (re)establish a secure connection with the ProSe Function in HPLMN to which it shall then send a Match Report (ProSe Application Code(s), UE Identity, Monitored PLMN ID) message to the ProSe Function in HPLMN. The ProSe Application Code is the code that the corresponding Discovery Filter of the UE matched. This request is always sent to the ProSe Function in HPLMN. The UE Identity is set to e.g. IMSI. The Monitored PLMN ID is the PLMN in which the UE has monitored the ProSe Application Code.

NOTE: How the Monitored PLMN ID is derived will be defined in RAN specifications.

2. The ProSe Function shall check the context for this UE that contains its subscription parameters. The authorisation information also contains the PLMN that this UE is allowed to perform discovery. The HSS provides the MSISDN of the UE.
3. The ProSe Function analyses the ProSe Application Code received from the UE.

If the PLMN ID that assigned the given ProSe Application Code is another Local PLMN then steps 4-7 are executed, otherwise (i.e. the ProSe Application Code was assigned by HPLMN) only step 7 is executed:

4. The ProSe Function in HPLMN sends a Match Report (ProSe Application Code(s), UE identity, Monitored PLMN ID) to the ProSe Function of the PLMN that assigned the ProSe Application Code. The UE identity information e.g. IMSI or MSISDN can be used by the ProSe Function in Local PLMN to perform charging.
5. The ProSe Function analyses the ProSe Application Code(s) received from the UE. As the "announcing" UE is not roaming, the ProSe function only needs to check whether the received ProSe Application Code(s) is still valid.
6. If the ProSe Application Code is confirmed then the ProSe Function in Local PLMN shall send Match Report Acknowledgement (ProSe Application ID Name(s), validity timer(s)). This message may also contain certain metadata corresponding to the ProSe Application ID Name e.g. postal address, phone number, URL etc.

7. The ProSe Function in HPLMN shall respond to the UE with Match Report Acknowledgment (ProSe Application ID(s), validity timer(s)). This message may also contain certain metadata corresponding to the ProSe Application ID Name e.g. postal address, phone number, URL etc. The validity timer(s) indicate for how long the mapping of ProSe Application Code(s) and ProSe Application ID(s) provided are going to be valid. The UE stores the mapping of ProSe Application Code(s) and corresponding ProSe Application ID(s) for the duration of their validity timer.

### 5.3.4.2 Match reporting (roaming)

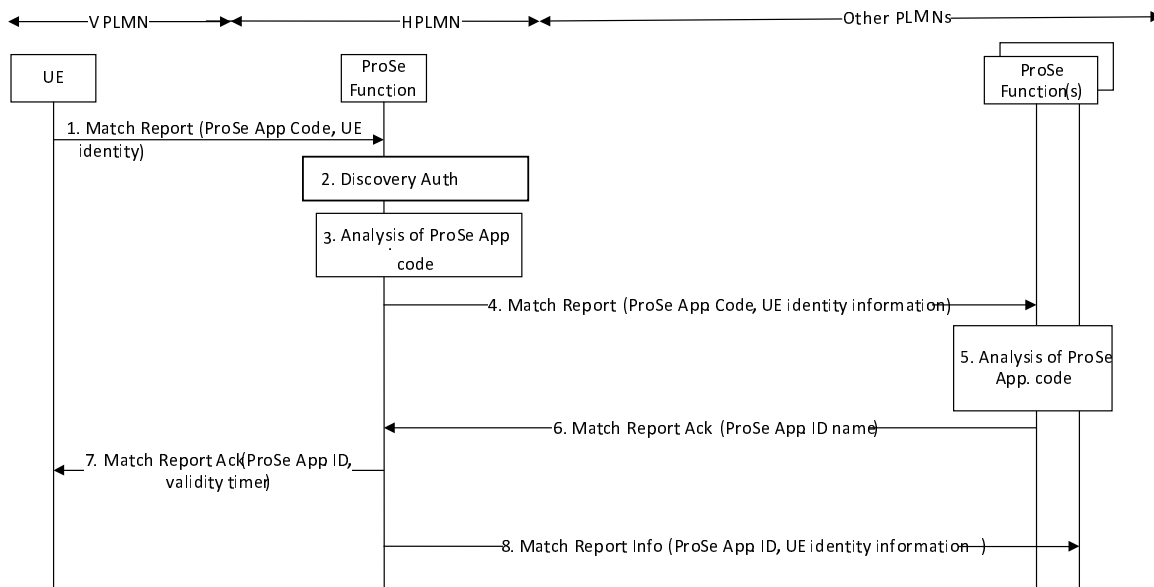

**Figure 5.3.4.2-1: Match report procedure (roaming)**

1. If the UE finds ProSe Application Code(s) that matches the Discovery Filters and does not have ProSe Application ID(s) already locally stored that correspond to this ProSe Application Code(s), it (re)establishes a secure connection with the ProSe Function in HPLMN and sends a Match Report (ProSe Application Code(s), UE Identity, VPLMN ID, Monitored PLMN ID) message to the ProSe Function in HPLMN. The ProSe Application Code is the code that the corresponding Discovery Filter of the UE matched. The UE Identity is set to e.g. IMSI. The Monitored PLMN ID is the PLMN in which the UE has monitored the ProSe Application Code.

NOTE 1: The Monitored PLMN ID is needed in order to cover the case that the announcing UE that broadcast the ProSe Application Code was registered in another PLMN.

NOTE 2: How the Monitored PLMN ID is derived will be defined in RAN specifications.

2. The ProSe Function shall check the context for this UE that contains its subscription parameters for this UE. The authorisation information also contains the PLMN that this UE is allowed to perform discovery. The UE context also contains the VPLMN ID where the UE is registered. The HSS provides the MSISDN of the UE.

3. The ProSe Function analyses the ProSe Application Code(s) received from the UE.

If the PLMN ID that assigned the given ProSe Application Code is not the HPLMN, then steps 4-8 are executed, otherwise (i.e. the HPLMN assigned the ProSe Application Code) only steps are executed:

4. The ProSe Function in HPLMN sends a Match Report (ProSe Application Code(s), UE identity, Monitored PLMN ID) to the ProSe Function of the PLMN that assigned the ProSe Application Code (i.e. the ProSe Function of the HPLMN of the "announcing UE"). The UE identity information e.g. IMSI or MSISDN can be used by the ProSe Function in Local PLMN to perform charging.

5. The ProSe Function ensures that the received ProSe Application Code is authorized to be transmitted on the monitored PLMN. The ProSe Function analyses the ProSe Application Code(s) received from the UE, and confirms the ProSe Application Code(s).

6. The ProSe Function shall send Match Report Acknowledgement (ProSe Application ID Name(s), validity timer(s)). This message may also contain certain metadata corresponding to the ProSe Application ID Name e.g. postal address, phone number, URL etc.
7. The ProSe Function in HPLMN shall respond to the UE with Match Report Acknowledgment (ProSe Application ID(s), validity timer(s)). This message may also contain certain metadata corresponding to the ProSe Application ID Name e.g. postal address, phone number, URL etc. The validity timer(s) indicate for how long the mapping of ProSe Application Code(s) and ProSe Application ID(s) provided are going to be valid. The UE stores the mapping of ProSe Application Code(s) and corresponding ProSe Application ID(s) for the duration of their validity timer.
8. If in step 4 of clause 5.3.3.5 it was indicated that the "announcing UE" is roaming, the ProSe Function in HPLMN may optionally send a Match Report Info (ProSe Application ID(s), UE Identity) to the ProSe Function of the serving PLMN of the "announcing UE".

## 5.4 Procedures for ProSe Direct Communication

### 5.4.1 One-to-many ProSe Direct Communication general

One-to-many ProSe Direct Communication is applicable only to ProSe-enabled Public Safety UEs and when authorised, can apply when the UE is served by E-UTRAN and when the UE is outside of E-UTRA coverage.

One-to-many ProSe Direct Communication has the following characteristics:

- One-to-many ProSe Direct Communication is connectionless. Thus there is no signalling over PC5 control plane.
- There is no QoS support apart from priority handling.
- The radio layer provides a user plane communication service for transmission of IP packets between UEs engaged in direct communication.
- Members of a group share a secret from which a group security key may be derived to encrypt all user data for that group.
- Authorisation for one-to-many ProSe Direct Communication is configured in the UE by the ProSe Function using PC3 reference point.
- ProSe UE configuration parameters (e.g. including ProSe Group IP multicast addresses, ProSe Group IDs, Group security material, radio related parameters) are configured in the UE.

### 5.4.2 One-to-many ProSe Direct Communication transmission

This procedure is applicable to authorized ProSe-enabled Public Safety UEs.

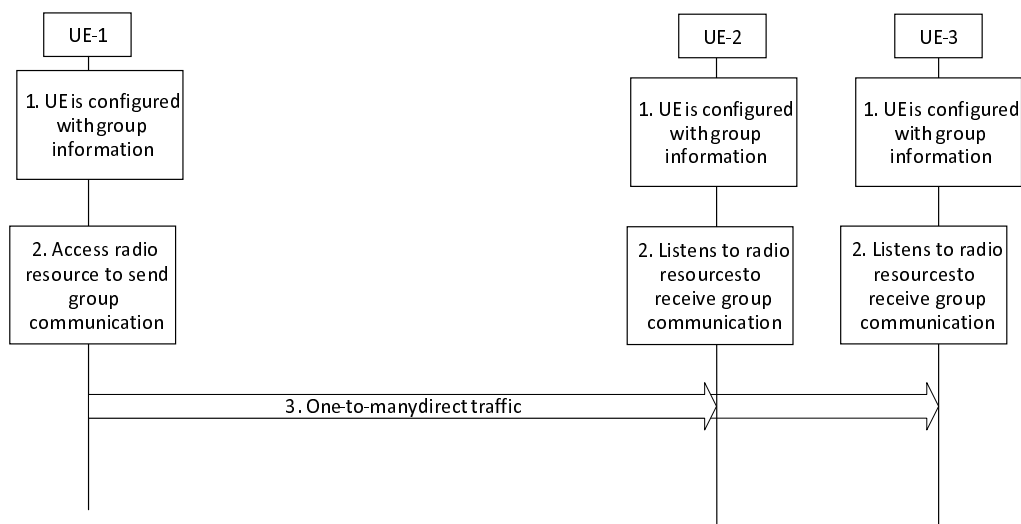

**Figure 5.4.2-1: One-to-many ProSe Direct Communication transmission**

1. UE is configured with the related information for one-to-many ProSe Direct Communication as defined in clause 4.5.1.1.2.3.3. The UE obtains the necessary group context (ProSe Layer-2 Group ID, ProSe Group IP multicast address) to transmit IP-layer transport of data, and also the radio resource related parameters used for the Direct Communication.
2. The originating UE finds the appropriate radio resource to conduct one-to-many ProSe Direct Communication as specified in clause 4.5.1.1.2.1.

The protocol data unit passed for transmission to the Access Stratum is associated with a Layer-3 protocol data unit type. In this release of the specification the following Layer-3 protocol data types are supported: IP packet and Address Resolution Protocol packet (see RFC 826 [28]).

The packet passed for transmission to the Access Stratum is associated with the corresponding Source Layer-2 ID and Destination Layer-2 ID. The Source Layer-2 ID is set to the ProSe UE ID assigned from the ProSe Key Management Function. The Destination Layer-2 ID is set to the ProSe Layer-2 Group ID.

NOTE: More details about step 2 to be defined in RAN specifications.

3. The originating UE sends the IP data to the IP multicast address using the ProSe Layer-2 Group ID as Destination Layer-2 ID.

### 5.4.3 One-to-many ProSe Direct Communication reception

This procedure is only applicable to authorized ProSe-enabled Public Safety UEs.

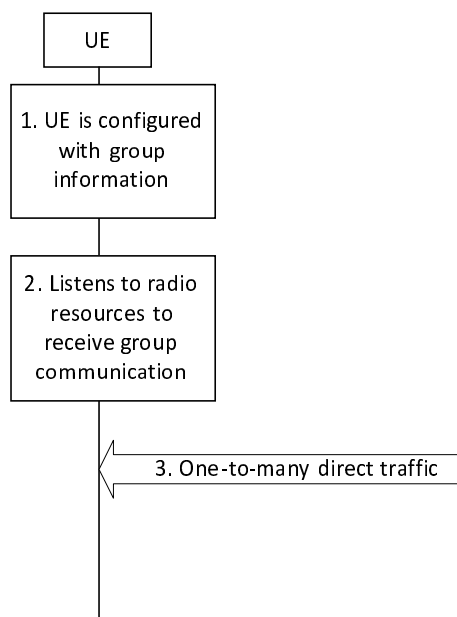

**Figure 5.4.3-1: One-to-many Direct Communication reception**

1. UE is configured with the related information for one-to-many ProSe Direct Communication as defined in clause 4.5.1.1.2.3.3. The UE obtains the necessary group context (ProSe Layer-2 Group ID, Group IP multicast address) to receive IP-layer transport of data, and also the radio resource related parameters used for the Direct Communication.
2. The receiving UE listens to the allocated radio resource to receive one-to-many ProSe Direct Communication.

NOTE: More details about step 2 to be defined in RAN specifications.

3. The receiving UE filters out the received frames based on the ProSe Layer-2 Group ID contained in the Destination Layer-2 ID and if it matches one of the configured Group IDs, it delivers the enclosed packet to the upper layers. The IP stack filters the received packets based on the Group IP multicast address.

The protocol data unit passed to the upper layers is associated with a Layer-3 protocol data unit type. In this release of the specification the following Layer-3 protocol data types are supported: IP packet and Address Resolution Protocol packet (see RFC 826 [28]).

## 5.4.4 Direct communication via ProSe UE-to-Network Relay

### 5.4.4.1 General

ProSe UE-to-Network Relay capable UE may attach to the network (if it is not already connected) and connect to a PDN connection enabling the necessary relay traffic or it may need to connect to additional PDN connection(s) in order to provide relay traffic towards Remote UE(s). PDN connection(s) supporting UE-to-Network Relay shall only be used for Remote ProSe UE(s) relay traffic.

## 5.4.4.2 IPv6 Stateless Address auto-configuration

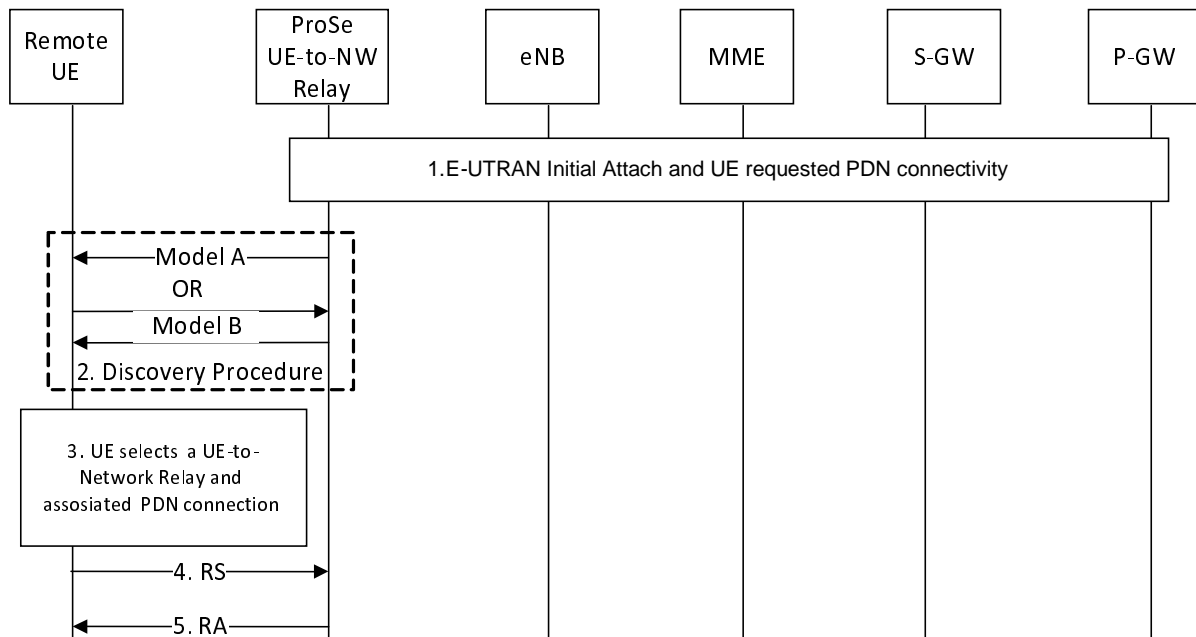

**Figure 5.4.4.2-1: Direct communication via ProSe UE-to-Network Relay (IPv6 prefix allocation)**

1. The ProSe UE-to-Network Relay obtains IPv6 prefix via prefix delegation function from the network as defined in TS 23.401 [5], if no PDN connection for this relaying exists.
2. The ProSe UE-to-Network Relay (to allow either Model A or Model B discovery) provides information assisting the Remote UE to perform "relay selection" e.g. if more than one relay is "announcing" in proximity of the Remote UE. The ProSe UE-to-Network Relay also indicates whether it supports the ability to receive signalling from the Remote UE.
3. The Remote UE uses the received relay selection information to select the ProSe UE-to-Network Relay and selects a ProSe UE ID (of the selected ProSe UE-to-Network Relay) that corresponds to the PDN connection it wants to connect through.
4. If the PDN type associated with the PDN connection is IPv4v6 or IPv6 and the Remote UE is configured to perform IPv6 Stateless Address auto-configuration, the Remote UE shall send a Router Solicitation message to the network to the Layer-2 link ID of the Relay corresponding to the PDN connection the Remote UE has selected, in order to solicit a Router Advertisement message. The message is sent using as Destination Layer-2 Address the ProSe UE ID of the ProSe UE-to-Network Relay discovered in step 2.
5. Upon receiving the Route Solicitation message from the UE the ProSe UE-to-Network Relay shall send an IPv6 Router Advertisement message as specified in IETF RFC 4862 [6] to the UE for PDN connection type IPv4v6 or IPv6 (i.e. the ProSe UE-to-Network Relay acts as an advertising interface as specified in IETF RFC 4861 [10] for the PDN connection type IPv4v6 or IPv6). The Router Advertisement messages shall contain the assigned IPv6 prefix received during the establishment of the PDN connection selected by the Remote UE. After the Remote UE receives the Router Advertisement message, it constructs a full IPv6 address via IPv6 Stateless Address auto-configuration in accordance with IETF RFC 4862 [6]. However, the Remote UE shall not use any identifiers defined in TS 23.003 [12] as the basis for generating the interface identifier. For privacy, the Remote UE may change the interface identifier used to generate the full IPv6 address, as defined in TS 23.221 [11] without involving the network. The Remote UE shall use the auto-configured IPv6 address while sending packets in this implicitly created PDN connection.

### 5.4.4.3 IPv4 Address allocation using DHCPv4

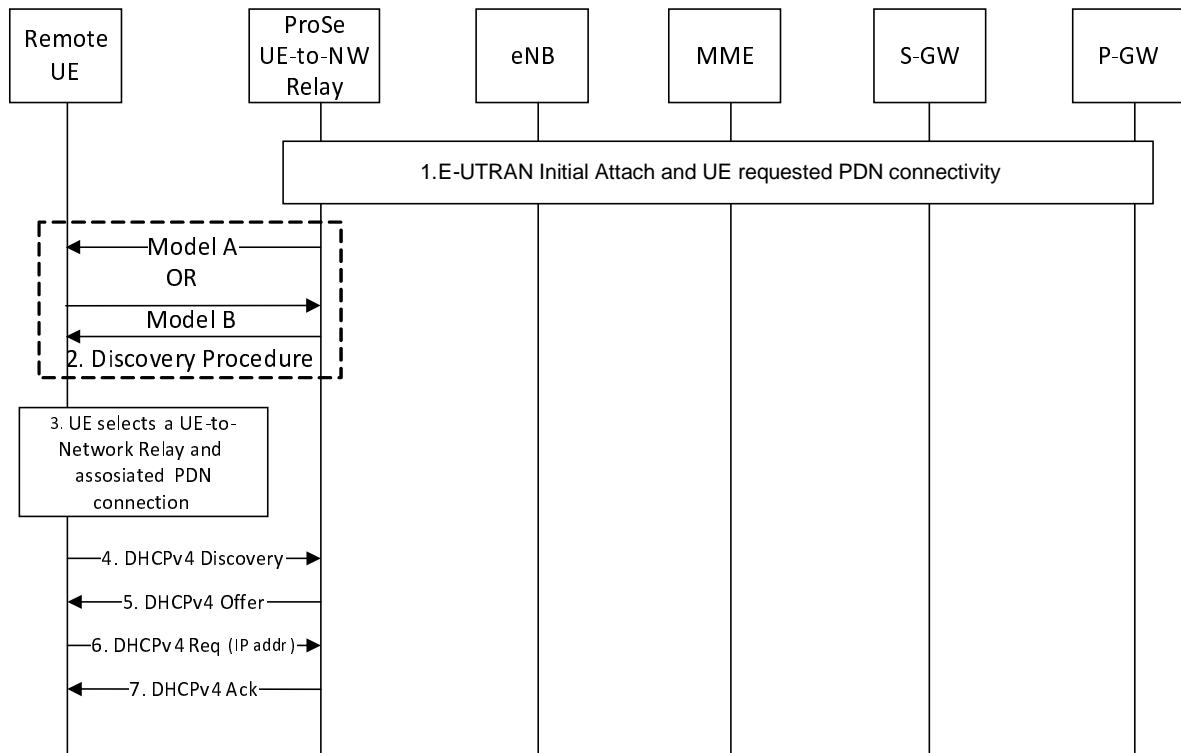

**Figure 5.4.4.3-1: Direct communication via ProSe UE-to-Network Relay (using DHCPv4)**

- 1-3. The IPv4 equivalent of steps 1-3 in clause 5.4.4.2.
4. If the PDN type associated with the PDN connection is IPv4v6 or IPv4 and the Remote UE is configured to perform DHCPv4 [7], the Remote UE shall send DHCPv4 Discovery message. The message shall be sent using as Destination Layer-2 Address the ProSe UE ID of the ProSe UE-to-Network Relay discovered in step 2.
5. The ProSe UE-to-Network Relay acting as a DHCPv4 Server sends the DHCPv4 Offer with the assigned Remote UE IPv4 address corresponding to the PDN connected selected by the Remote UE.
6. When the Remote UE receives the lease offer, it sends a DHCP REQUEST message containing the received IPv4 address.
7. The ProSe UE-to-Network Relay acting as DHCPv4 server sends a DHCPACK message to the Remote UE. This message includes the lease duration and any other configuration information that the client might have requested.

On receiving the DHCPACK message, the Remote UE completes the TCP/IP configuration process.

NOTE: The DHCPv4 client may skip the DHCPv4 Discovery phase, and send DHCPv4 Request message in broadcast as the first message in accordance with the DHCPv4 renewal process.

## 5.5 EPC-level ProSe Discovery procedures

### 5.5.1 General

EPC-level ProSe Discovery can be used independently or in conjunction with EPC support for WLAN direct discovery and communication.

When EPC support for WLAN direct discovery and communication is requested as part of the EPC-level ProSe Discovery procedure, the additional parameters for support of WLAN direct discovery and communication are enclosed in brackets in the figures.



## 5.5.2 Overall call flow for EPC-level ProSe Discovery

The overall call flow for EPC-level ProSe Discovery and optional EPC support for WLAN direct discovery and communication is illustrated in Figure 5.5.2-1. Each procedural box is subsequently described in more detail as a separate call flow.

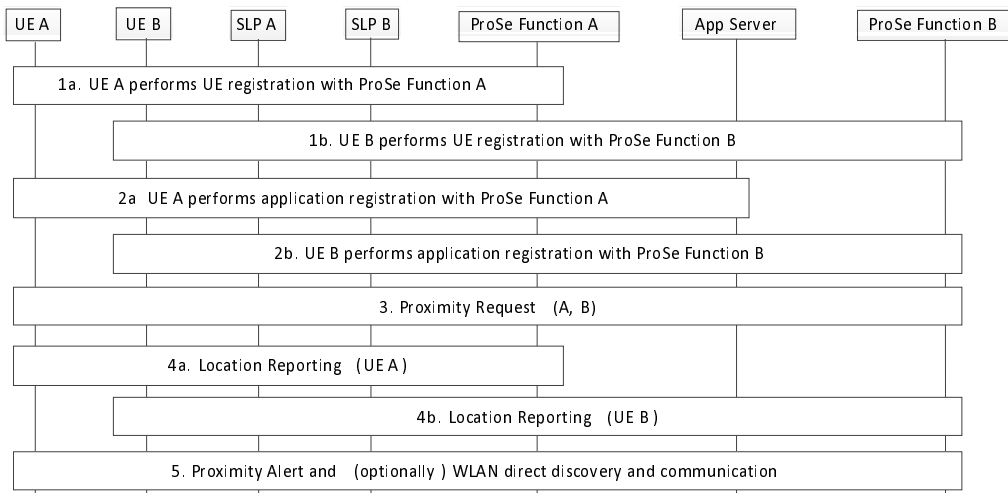

**Figure 5.5.2-1: Overall call flow for EPC-level ProSe Discovery and optional EPC support for WLAN direct discovery and communication**

1. UEs perform UE registration for ProSe with the ProSe Function residing in their respective Home PLMNs;
2. UEs perform application registration for ProSe with the ProSe Function residing in their respective Home PLMNs;
3. UE A makes a proximity request for UE B, i.e. requests that it be alerted for proximity with UE B (possibly indicating a window of time during which the request is valid). In response, ProSe Function A requests location updates for UE A and UE B. These location updates can be periodic, based on a trigger, or a combination of both. To request location updates for UE A, ProSe Function A contacts SUPL Location Platform (SLP) A. To request location updates for UE B, ProSe Function A contacts ProSe Function B, which requests location updates for UE B from SLP B;
4. The UEs' locations are reported to their respective ProSe Functions intermittently. ProSe Function B forwards UE B's location updates to ProSe Function A based on the conditions set by ProSe Function A. Whenever ProSe Function A receives location updates for UE A and/or UE B, it performs proximity analysis on UE A and UE B's locations;
5. When ProSe Function A detects that the UEs are in proximity, it informs UE A that UE B is in proximity and (optionally) provides UE A with assistance information for WLAN direct discovery and communication with UE B. ProSe Function A also informs ProSe Function B, which in turn informs UE B of the detected proximity and (optionally) provides UE B with assistance information for WLAN direct discovery and communication with UE A.

## 5.5.3 UE registration for ProSe

To obtain ProSe service a ProSe-enabled UE needs to register with the ProSe Function.

Depicted in Figure 5.5.3-1 is the procedure for UE registration for ProSe.

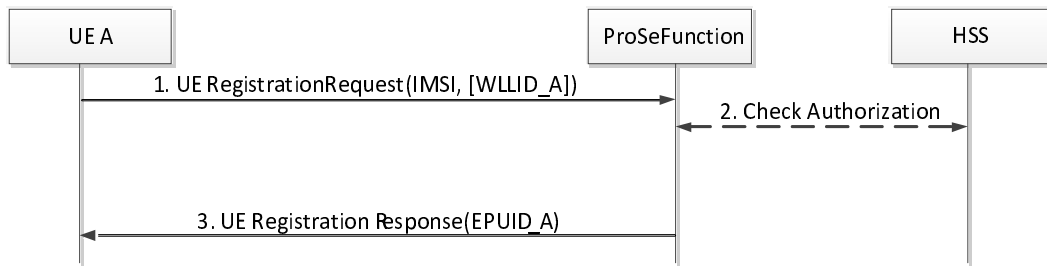

**Figure 5.5.3-1: UE registration for ProSe**

1. To select ProSe Function A, UE A constructs an FQDN using the serving PLMN ID and relies on DNS translation to obtain the IP address of ProSe Function A. UE A registers with ProSe Function A by sending a UE Registration Request (IMSI, [WLLID\_A]) message.

If UE A intends to use EPC support for WLAN direct discovery and communication and if it uses a permanent WLAN Link Layer ID, the message also includes UE A's permanent WLAN Link Layer ID (WLLID\_A). Alternatively, the UE may obtain a temporary WLAN Link Layer ID from the ProSe Function as part of the Proximity Request procedure.

2. ProSe Function A may interact with the HSS in order to authenticate the user and check whether the user is authorised for ProSe. Alternatively, all user settings related to authentication and authorisation for ProSe may be configured locally in ProSe Function A, in which case the interaction with the HSS is not needed.
3. ProSe Function A generates an EPC ProSe User ID for UE A (EPUID\_A), stores the EPUID\_A together with user's IMSI and responds to UE A by sending a UE Registration Response (EPUID\_A) message.

### 5.5.4 Application registration for ProSe

When a user registers with a 3rd party application server, he/she is designated an Application Layer User ID (e.g. ALUID\_A for user A). This procedure is out of 3GPP specification scope. Then to activate ProSe features such as EPC-level ProSe Discovery for a specific application, the UE registers the application with the ProSe Function, as illustrated in Figure 5.5.4-1.

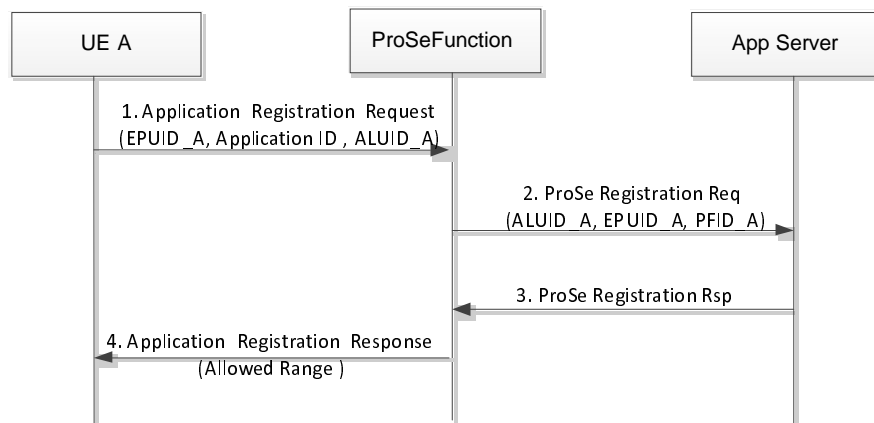

**Figure 5.5.4-1: Application registration for ProSe**

1. UE A sends Application Registration Request (EPUID\_A, Application ID, ALUID\_A) message to ProSe Function A to register an application for ProSe. EPUID\_A is the EPC ProSe User ID for UE A. The Application ID is used to identify the 3rd party App Server platform. ALUID\_A is user A's Application Layer User ID.
2. ProSe Function A uses EPUID\_A to retrieve user's profile, checks that the requested application is on the stored list of authorised Application IDs and sends a ProSe Registration Request (ALUID\_A, EPUID\_A, PFID\_A) message to the App Server indicating that a user of this application (identified as ALUID\_A) has requested to

use ProSe for that application. PFID\_A is the ProSe Function ID of ProSe Function A. If the App Server accepts the request, it stores the user's Application Layer User ID (ALUID\_A) and EPC ProSe User ID (EPUID\_A) together with the PFID\_A.

3. The App Server sends a ProSe Registration Response message to ProSe Function A indicating that the registration was successful (or not).
4. ProSe Function A sends Application Registration Response (Allowed Range) message to UE A indicating that the registration was successful (or not). The Allowed Range parameter contains the set of range classes that are allowed for this application.

### 5.5.5 Proximity Request

In order to request that it be alerted when it enters proximity with user B, UE A triggers the Proximity Request procedure, as illustrated in Figure 5.5.5-1.

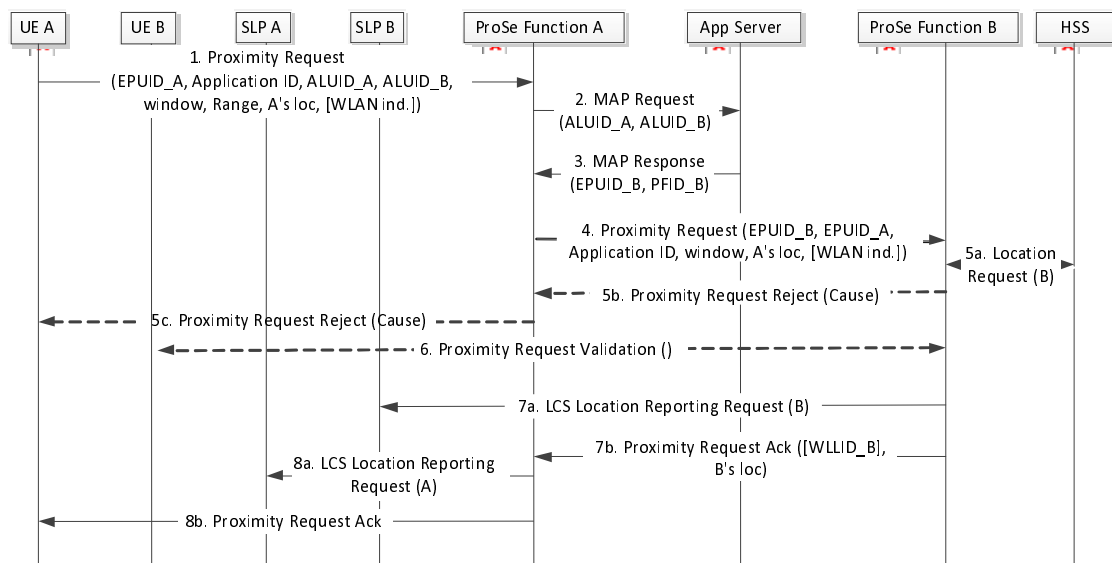

Figure 5.5.5-1: Proximity Request

1. UE A sends a Proximity Request (EPUID\_A, Application ID, ALUID\_A, ALUID\_B, window, Range, A's location, [WLAN indication]) message to ProSe Function A. The Application ID parameter identifies the 3rd party App Server platform. ALUID\_A and ALUID\_B are the Application Layer User IDs for users A and B, respectively. The window parameter indicates the time period during which the request is valid. Range is a requested range class for this application chosen from the set of allowed range classes. A's location is the current location of UE A with the best accuracy known by UE A. UE A may optionally request EPC support for WLAN direct discovery and communication with UE B by adding the WLAN indication.
2. ProSe Function A sends a Map Request (ALUID\_A, ALUID\_B) message to the App Server, requesting that it provide the EPC ProSe User ID for the targeted user B. ProSe Function A stores the Application Layer User IDs (ALUID\_A and ALUID\_B) until the execution of the Proximity Alert procedure described in clause 5.5.7, the Proximity Request Cancellation procedure described in clause 5.5.9 or until the expiry of the time window during which the request is valid.
3. The App Server checks user B's application-specific ProSe permissions, confirms that user A is allowed to discover user B, and sends a Map Response (EPUID\_B PFID\_B) message to ProSe Function A indicating user B's EPC ProSe User ID (EPUID\_B) as well as the ProSe Function ID of ProSe Function B (PFID\_B), ProSe Function A stores the EPUID\_B and PFID\_B until the execution of the Proximity Alert procedure described in clause 5.5.7, the Proximity Request Cancellation procedure described in clause 5.5.9 or until the expiry of the time window during which the request is valid.
4. ProSe Function A propagates the Proximity Request (EPUID\_B, EPUID\_A, Application ID, window, A's location, [WLLID\_A]) message to ProSe Function B, indicating a location update periodicity, trigger or both. A's location is the current location of UE A provided in step 1 expressed in in GAD shapes defined in

TS 23.032 [3]. WLAN indication is included if UE A has requested EPC support for WLAN direct discovery and communication in step 1.

5. Based on EPUID\_B received in the previous step, ProSe Function B retrieves subscriber B's record. ProSe Function B may request UE B's last known location via the HSS (step 5a). Based on the last known location of UE B obtained via the HSS and UE A's location and time window provided by ProSe Function A in step 4, ProSe Function B may determine that the users are unlikely to enter proximity within the requested time window and rejects the request by sending a Proximity Request Reject message towards UE A with an appropriate cause value (steps 5b and 5c), in which case the remaining steps of the procedure are skipped.
6. Depending on UE B's ProSe profile, UE B may be asked to confirm permission for the proximity request (e.g. user B may have temporarily disabled the ProSe function on UE B).
7. ProSe Function B requests location reporting on UE B from SLP B and acknowledges the proximity request to ProSe Function A and provides UE B's current location (if known). The WLAN Link Layer ID of UE B (WLLID\_B) is included if UE A has requested EPC support for WLAN direct discovery and communication in step 1 and if UE B uses a permanent WLAN Link Layer ID.
8. ProSe Function A requests location reporting on UE A from SLP A. If UE A's current location is available and if UE B's location was included in step 7, ProSe Function A may decide to cancel the Proximity Request procedure if it determines that the UEs are unlikely to enter proximity within the requested time window. Otherwise ProSe Function A acknowledges the proximity request to UE A.

## 5.5.6 UE Location Reporting

SLP A and SLP B configure UE A and UE B, respectively, to report their locations periodically, based on a trigger, or a combination of both depending on what ProSe Function A and ProSe Function B requested (see Figure 5.5.6-1).

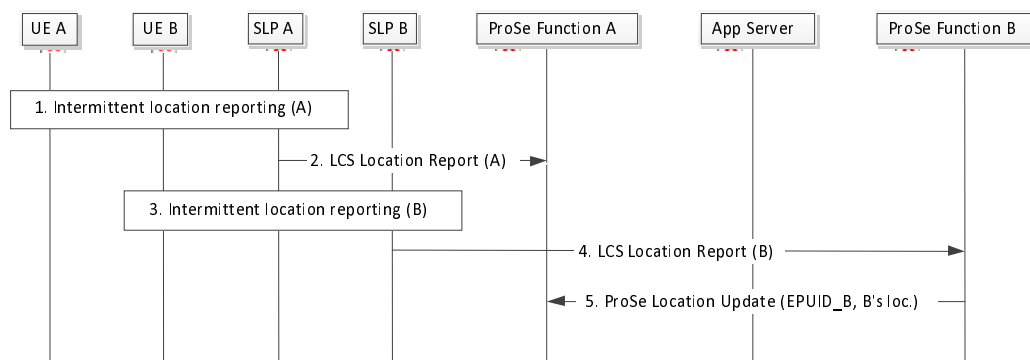

**Figure 5.5.6-1: UE location reporting**

- 1-4. The locations of UE A and UE B are reported to their corresponding ProSe Servers intermittently.

NOTE 1: If UE is engaged in multiple concurrent proximity request procedures, the location reports are grouped together by the SLP.

NOTE 2: The UE location reporting procedure is executed until the time window expires even if UE B "unfriends" UE A at application layer in the middle of an active proximity request.

5. Assuming that ProSe Function A is in charge of determining proximity, ProSe Function B forwards UE B's location to ProSe Function A periodically, based on a trigger criterion, or a combination of both as requested by ProSe Function A. The UE location information exchanged between ProSe Functions are expressed in GAD shapes defined in TS 23.032 [3]. ProSe Function A may decide to cancel the Proximity Request procedure if it determines that the UEs are unlikely to enter proximity within the requested time window.

## 5.5.7 Proximity Alert

When the UEs enter into proximity, the network triggers the Proximity Alert procedure, as illustrated in Figure 5.5.7-1.

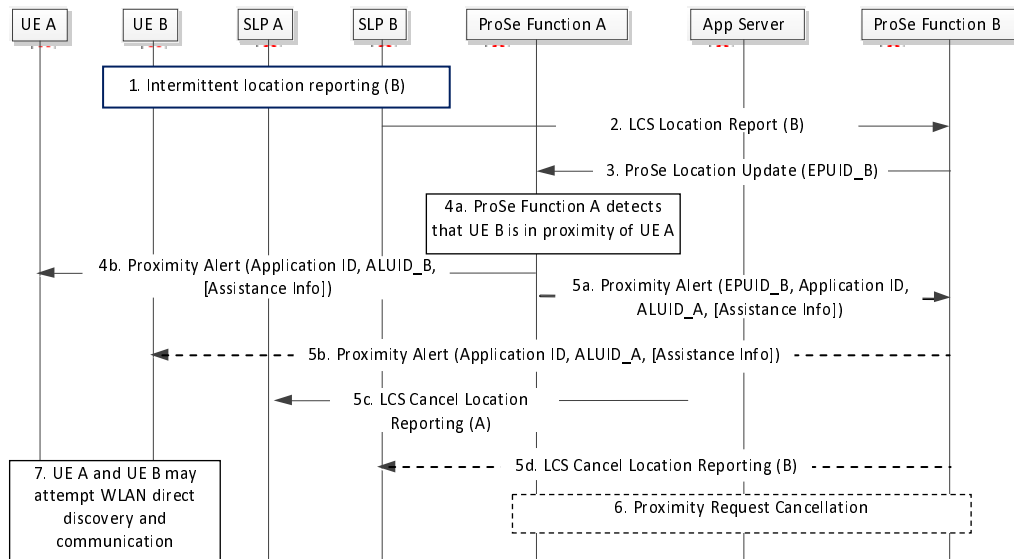

**Figure 5.5.7-1: Proximity Alert**

1-3. The location of UE B is reported to ProSe Function B, which forwards it to ProSe Function A.

4. ProSe Function A detects that the two UEs are in proximity based on the requested discovery range class and alerts UE A by sending a Proximity Alert (Application ID, ALUID\_B, Assistance Information) message. ALUID\_B is the Application Layer User ID of user B. The message optionally includes Assistance Information for WLAN direct discovery and communications with UE B.
5. If UE A has requested as part of the Proximity Request procedure as described in step 1 of clause 5.5.5 to be assisted for WLAN direct discovery and communication, ProSe Function A requests ProSe Function B to send a Proximity Alert (Application ID, ALUID\_A, Assistance Information) message to UE B. ALUID\_A is the Application Layer User ID of user A. The message includes Assistance Information for WLAN direct discovery and communication with UE A. ProSe Function A cancels location reporting on UE A from SLP A. ProSe Function B also cancels location reporting on UE B from SLP B.
6. If UE A has not requested as part of the Proximity Request procedure as described in step 1 of clause 5.5.5 to be assisted for WLAN direct discovery and communication, ProSe Function A initiates Proximity Request Cancellation by sending a Cancel Proximity Request (EPUID\_B, EPUID\_A) message to ProSe Function B as described in step 2 of clause 5.5.9.

NOTE 1: The WLAN interface in the UE need not be turned on before step 7 in Figure 5.5.7-1.

NOTE 2: The assistance information is designed to expedite WLAN direct discovery and communication. The content of the assistance information depends on the technology used on the WLAN direct link. All the content in the assistance information is dynamically generated by ProSe Function A, with the exception of WLLID\_B in case UE B supports only permanent WLLID.

## 5.5.8 UE deregistration for ProSe

### 5.5.8.1 General

At any time the UE or the ProSe Function may initiate UE deregistration for ProSe.

### 5.5.8.2 Network-initiated deregistration

Depicted in Figure 5.5.8.2-1 is the procedure for network-initiated deregistration for ProSe.

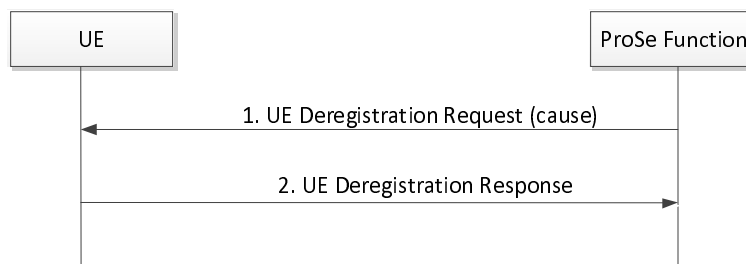
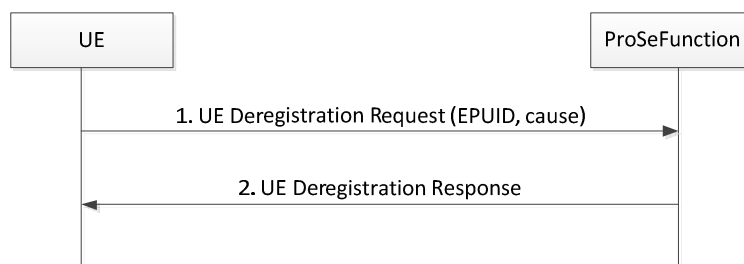

**Figure 5.5.8.2-1: Network-initiated deregistration for ProSe**

1. At any time the ProSe Function may decide to deregister the UE by sending a UE Deregistration Request (cause) message.
2. UE acknowledges the deregistration request by sending a UE Deregistration Response message.

### 5.5.8.3 UE-initiated deregistration

The UE may decide to deregister for ProSe (e.g. when there are no ProSe-enabled applications activated on the UE). Depicted in Figure 5.5.8.3-1 is the procedure for UE-initiated deregistration for ProSe.



**Figure 5.5.8.3-1: UE initiated deregistration**

1. At any time the UE may decide to deregister for ProSe by sending a UE Deregistration Request (EPUID, cause) message.
2. The ProSe Function acknowledges the deregistration request by sending a UE Deregistration Response message and removes the stored ProSe context for the UE.

## 5.5.9 Proximity Request Cancellation

The Proximity Request Cancellation may be initiated by the UE or the ProSe Function.

UE A may decide to cancel Proximity Request it sent earlier (e.g. due to change in its location, termination of corresponding application or due to completion of certain event). The ProSe Function A may cancel Proximity Request sent by UE A earlier (e.g. when time window is exceeded). In order to cancel Proximity Request, UE A triggers procedure as illustrated in Figure 5.5.9-1.

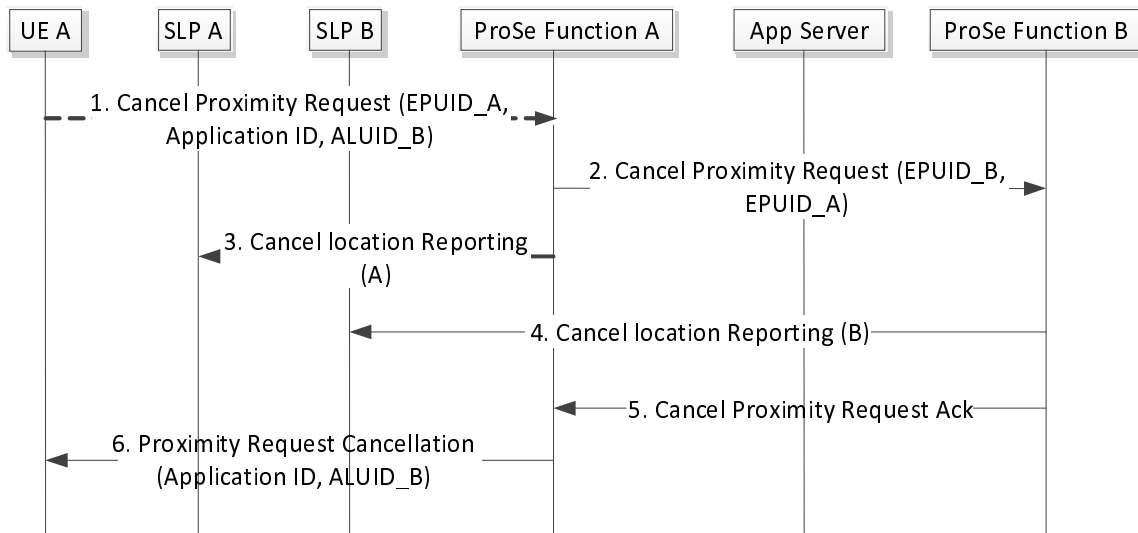

**Figure 5.5.9-1 Proximity Request Cancellation**

1. UE A sends Cancel Proximity Request (EPUID\_A, Application ID, ALUID\_B) to ProSe Function A. This optional step is performed only when the Proximity Request Cancellation procedure is initiated by the UE.
2. ProSe Function A sends the Cancel Proximity Request (EPUID\_B, EPUID\_A) message to ProSe Function B based on the stored PFID B information.
3. If there are no other pending proximity requests for UE A, ProSe Function A cancels location reporting on UE A from SLP A.
- 4-5. ProSe Function B cancels location reporting on UE B from SLP B and acknowledges the proximity request cancellation to ProSe Function A.
6. ProSe Function A sends Proximity Request Cancellation (Application ID, ALUID\_B) to UE A. The Application ID and ALUID\_B parameters are included only when the procedure is initiated by ProSe Function A.

## 5.6 EPC support for WLAN direct discovery and communication

### 5.6.1 General

The EPC network may decide to enable two or more ProSe-enabled WLAN-capable UEs to directly communicate using WLAN technology. This decision can be taken, for example, when the EPC network supports EPC-level ProSe discovery and becomes aware that two or more UEs are in close proximity, when the EPC network knows that UE-A requests to communicate with UE-B which is in close proximity of UE-A, etc.

### 5.6.2 Enabling of EPC assisted WLAN direct communication

Figure 5.6.2-1 shows how the EPC network enables UE-A and UE-B to directly communicate in WLAN direct mode. This is accomplished by triggering the two UEs to establish a WLAN direct group and providing them with assistance information which enables the EPC network to control and to expedite the establishment of the WLAN direct group.

With the procedure shown in Figure 5.6.2-1 the EPC network can (i) control when a WLAN direct group can be established, (ii) authorize the UEs that can become members of this group (and thus communicate with each other in WLAN direct mode) and (iii) control the operating parameters of the WLAN direct group e.g. the SSID, the security keys, etc.

**NOTE 1:** When the WLAN direct discovery and communication is based on the Wi-Fi Peer-to-Peer (P2P) specification [13], a WLAN direct group is autonomously established by one or more UEs without any network involvement. However, with the procedure shown in Figure 5.6.1-1 it is the EPC network that can authorize and trigger the establishment of WLAN direct groups. An example on the operating parameters provided by the ProSe Function when the direct communication is based on Wi-Fi Peer-to-Peer specification [13] can be found in Annex A.

NOTE 2: WLAN direct discovery and communication without Assistance Information from EPC is outside the scope of 3GPP.

The ProSe Function shown in Figure 5.6.2-1 is the network function that triggers and controls the establishment of a WLAN direct group between one or more UEs.

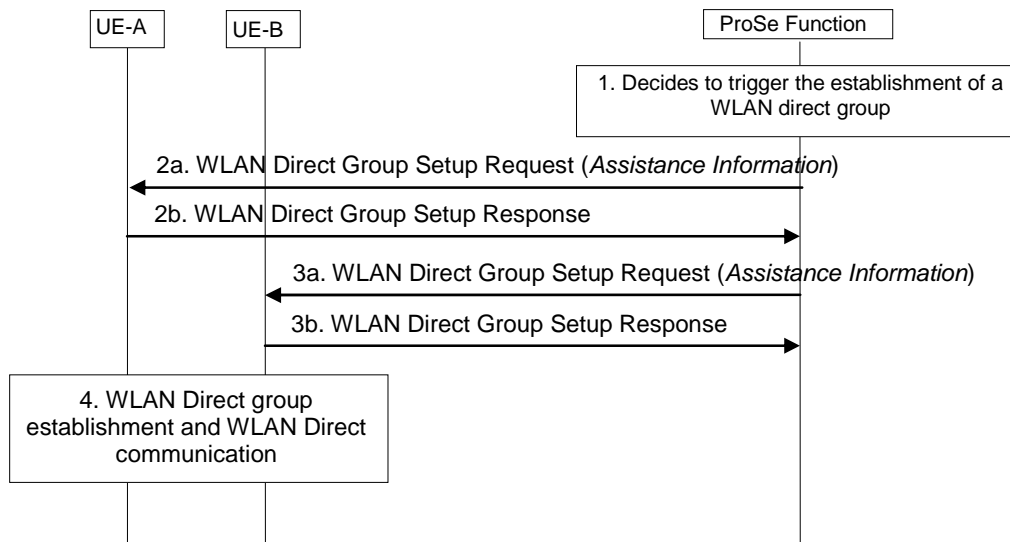

**Figure 5.6.2-1: Signalling flow for EPC support for WLAN direct communication**

1. The ProSe Function decides to trigger UE-A and UE-B to establish a WLAN direct group under the control of the network.
2. The ProSe Function sends a WLAN Direct Group Setup Request (Assistance Information) to UE-A. The Assistance Information is a set of parameters which can expedite the establishment of the WLAN direct group and enables the EPC network to control the operating parameters of the WLAN direct group. The Assistance Information content depends on the WLAN technology. If UE-A accepts the request and the offered Assistance Information, it responds with a WLAN Direct Group Setup Response. This response may include parameters for the WLAN direct group proposed by UE-A (e.g. an operating channel).

NOTE 2: When EPC support for WLAN direct discovery and communication is used in conjunction with EPC-level discovery, the assistance information for WLAN direct discovery and communication is provided as part of the Proximity Alert procedure.

3. The ProSe Function sends also a WLAN Direct Group Setup Request (Assistance Information) to UE-B. The Assistance Information in the request may take into account the parameters proposed by UE-A in step 2b.
4. The two UEs establish a WLAN direct group and may start communicating in WLAN direct mode.

NOTE 3: In this release of the specification it is assumed that UE-A and UE-B are controlled by the same ProSe Function.

### 5.6.3 Revocation of EPC assisted WLAN direct communication

At any time the ProSe Function may decide to revoke the EPC assisted WLAN direct communication as shown in Figure 5.6.3-1.



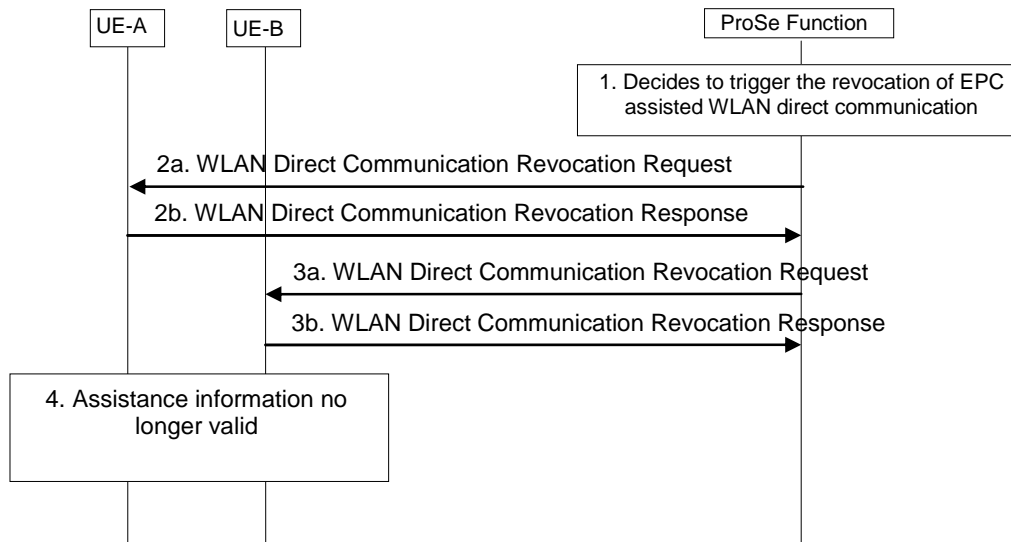

**Figure 5.6.3-1: Signalling flow for Revocation of EPC assisted WLAN direct communication**

1. The ProSe Function decides to revoke EPC assisted WLAN direct communication for UE-A and UE-B.
- 2a. The ProSe Function sends a WLAN Direct Communication Revocation Request to the UE-A.
- 2b. The UE-A accepts the request.
- 3a. The ProSe Function sends a WLAN Direct Communication Revocation Request (Control Information) to the UE-B.
- 3b. The UE-B accepts the request.
4. The EPC assisted WLAN direct communication Assistance Information is no longer valid and the EPC assisted WLAN direct communications using the EPC Assistance Information are released.

## 5.7 ProSe impacts to EPC procedures

### 5.7.1 E-UTRAN attach procedure for ProSe-enabled UEs

E-UTRAN attach for ProSe-enabled UE is performed as defined in TS 23.401 [5] with the following additions:

- ProSe-enabled UE includes the ProSe capability indication as part of the "UE Network Capability" in the Attach Request message. MME stores this information for ProSe operation. ProSe capability can indicate whether the UE is capable of supporting one or more of the following ProSe direct services: ProSe Direct Discovery, ProSe Direct Communication and ProSe UE-to-Network Relay.
- If the MME is configured to indicate "ProSe authorised" to E-UTRAN, the UE is ProSe-enabled, and the UE is authorised to use ProSe direct services based on the subscription data, the MME shall include a "ProSe authorised" indication in the S1 AP Initial Context Setup Request, indicating which of the ProSe direct services the UE is authorised to use.

### 5.7.2 Service Request procedures for ProSe-enabled UEs

Service Request procedures for ProSe-enabled UE are performed as defined in TS 23.401 [5] with the following additions:

- If the MME is configured to indicate "ProSe authorised" to E-UTRAN, the UE is ProSe-enabled, and the UE is authorised to use ProSe direct services based on the subscription data, the MME shall include a "ProSe authorised" indication in the S1 AP Initial Context Setup Request, indicating which of the ProSe direct services the UE is authorised to use.

### 5.7.3 PS Handover procedures for ProSe-enabled UEs

Intra-E-UTRAN S1-based handover or the Inter-RAT to E-UTRAN handover procedures for ProSe-enabled UE are performed as defined in TS 23.401 [5] with the following additions:

- If the MME is configured to indicate "ProSe authorised" to E-UTRAN, the UE is ProSe-enabled, and the UE is authorised to use ProSe direct services based on the subscription data, the target MME shall send the "ProSe authorised" indication to the target eNodeB as follows:
  - For the intra MME handover, the "ProSe authorized" indication is included in the S1-AP handover Request message. If after the handover procedure, the "ProSe authorized" indication is changed, the updated "ProSe authorized" indication is included in the S1-AP UE Context Modification Request message sent to the target eNodeB.
  - For the inter MME handover, the "ProSe authorized" indication is included in the S1-AP UE Context Modification Request message sent to the target eNodeB after the handover procedure.

For X2-based handover, the "ProSe authorized" indication is sent to target eNodeB as follows:

- If the source eNodeB is ProSe-enabled and the "ProSe authorized" indication is included in the UE context, the source eNodeB shall include a "ProSe authorised" indication in the X2-AP Handover Request message to the target eNodeB.
- If the MME is configured to indicate "ProSe authorised" to E-UTRAN, the UE is ProSe-enabled, and the UE is authorised to use ProSe direct services based on the subscription data, the MME shall send the "ProSe authorised" indication to the target eNodeB in the Path Switch Request Acknowledge message. If after the handover procedure, the "ProSe authorized" indication is changed, the updated "ProSe authorized" indication is included in the S1-AP UE Context Modification Request message sent to the target eNodeB.

The "ProSe authorised" indication sent to target eNodeB denotes which of the ProSe direct services UE is authorized to use.

### 5.7.4 Tracking Area Update procedure for ProSe-enabled UEs

Tracking Area Update procedures for ProSe-enabled UE are performed as defined in TS 23.401 [5] with the following additions:

- ProSe-enabled UE includes the ProSe capability indication as part of the "UE Network Capability" in the Tracking Area Update Request message. MME stores this information for ProSe operation.
- If the MME is configured to indicate "ProSe authorised" to E-UTRAN and determines to re-establish the radio and S1 bearers for all active EPS bearer contexts due to the "active" flag included in the Tracking Area Update Request message or the pending downlink data or signalling, the UE is ProSe-enabled, and the UE is authorised to use ProSe direct services based on the subscription data, the MME shall include a "ProSe authorised" indication in the S1-AP Initial Context Setup Request.

### 5.7.5 Insert Subscriber Data procedure for ProSe-enabled UEs

Insert Subscriber Data procedure for ProSe-enabled UE are performed as defined in TS 23.401 [5] with the following additions:

- If the "ProSe authorised" indication needs to be changed due to the changed subscription data and the S1 bearer is established, the MME shall notify the eNodeB the updated "ProSe authorised" indication via the S1-AP UE Context Modification Request message.

---

# Annex A (informative): Assistance Information for EPC support for WLAN direct discovery and communication

## A.1 General

This Annex presents an example how the Assistance Information can be designed to expedite WLAN direct discovery and communication. The Assistance Information content depends on the WLAN technology.

---

## A.2 Wi-Fi Peer-to-Peer

Wi-Fi Peer-to-Peer (P2P) specification [13] defines an architecture and set of protocols that facilitate direct discovery and communication using the IEEE 802.11 technology [14].

To assist WLAN direct discovery and communication as required by the Wi-Fi P2P technology [13] the EPC needs to supply some or all of the following items as part of the Assistance Information:

- SSID: The SSID to use for Wi-Fi P2P operation. To be compliant with the Wi-Fi P2P specification [13] the SSID should be in the form "DIRECT-ab" where a, b are two random characters.
- WLAN Secret Key: The pre-shared key to be used by UEs to secure their Wi-Fi P2P communication. This is used by UEs as the Pairwise Master Key (PMK).
- Group Owner indication: If set, the UE should implement the Group Owner (GO) functionality specified in the Wi-Fi P2P specification [13]. The UE implementing this functionality essentially becomes an AP that transmits Beacons with the P2P Information Element and accepts associations from other Wi-Fi P2P devices or from legacy Wi-Fi devices (those not implementing the Wi-Fi P2P functionality). If not set, the UE should behave as a Wi-Fi P2P client that attempts to discover and associate with a GO.
- P2P Device Address of self: This is the WLAN Link Layer ID to be used by a UE when participating in a Wi-Fi P2P group.
- P2P Device Address of peers: This is a list of WLAN Link Layer IDs provided to a UE implementing the Group Owner functionality in a Wi-Fi P2P group. Such UEs should accept WLAN association requests only from devices that are included in this list.
- Operation channel: The channel on which Wi-Fi P2P discovery and communication should take place.
- Validity time: The time period during which the content provided in the assistance information is valid.

# Annex B (informative): Wild carded ProSe Application IDs

## B.1 General

The wildcard indicator, in the MCC or MNC part of the PLMN ID of the ProSe Application ID indicates whether this particular ProSe Application ID is PLMN specific (in which case neither MCC nor MNC will be wild carded) or countrywide (in which case the MNC part will be wild-carded) or global (in which case both the MCC and MNC parts will be wild-carded).

Countrywide or global ProSe Application IDs belong in different data structures that are managed by "authorities" not associated with a specific PLMN.

Notwithstanding the description in this annex, showing both PLMN specific and country-wide or global data structures, this does not preclude that in the future the country-wide or global data structures may supersede the PLMN specific data structures.

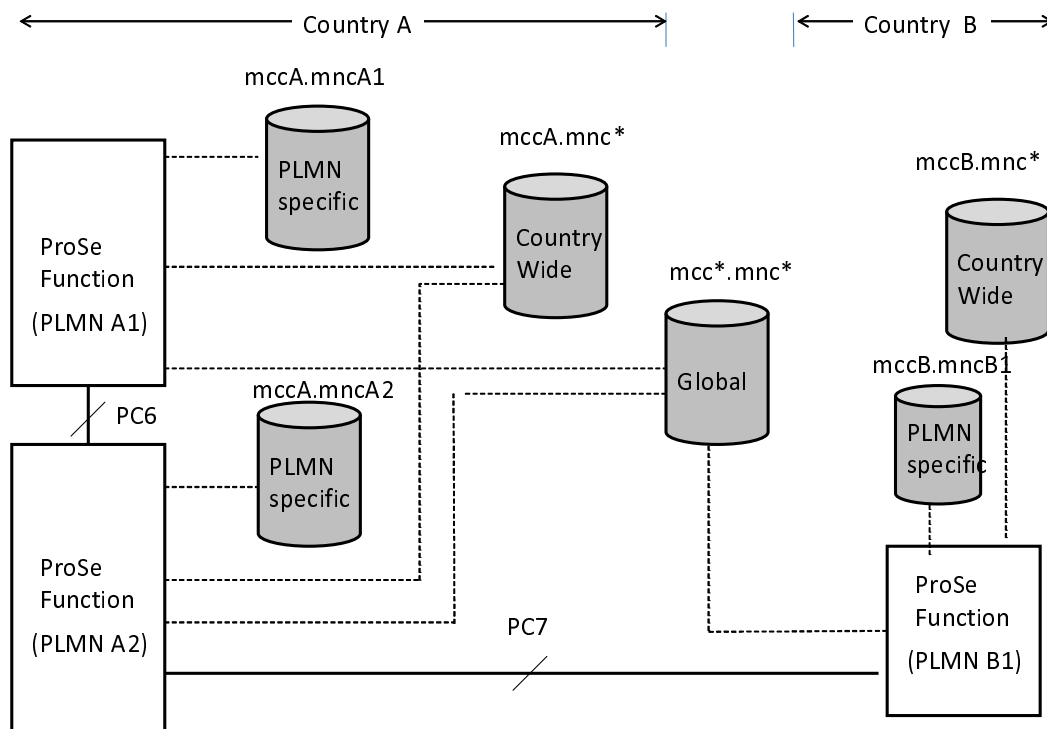

**Figure B.2-1: Country-wide, global and PLMN specific ProSe Application IDs**

This arrangement between the PLMN and the "authority" that allocates these ProSe Application IDs is out of scope of 3GPP in this release of the specification.

NOTE: The interfaces between the ProSe Functions and the repositories of global or country-wide ProSe Application IDs/ProSe Application Codes that are shown in figure B.2-1 is out of scope of 3GPP in this Release.

## B.2 Use of wild-carded ProSe Application IDs

The monitoring or announcing UE can request to monitor or announce a ProSe Application Code that has countrywide or global scope following the procedures defined in clause 5.3.3 by wildcarding accordingly the MNC element of the

PLMN ID of the ProSe Application ID (for countrywide) or both the MCC and MNC (for global) elements of the PLMN ID of the ProSe Application ID.

The monitoring UE will have to know whether to send a monitoring request for PLMN specific, or countrywide, or global ProSe Application ID, based on the configuration that applies to the particular data structure.

If country-wide or global data structures are used then PC6 and PC7 interfaces are not used for monitoring requests.

For example if the UE is interested to monitor or announce for restaurants that are registered in a configured PLMN specific data structure (e.g., local restaurants in a particular geographical area) it will send a monitoring request that contains only the following PLMN specific ProSe Application ID. If on the other hand the UE is interested to monitor or announce for restaurants that are registered in the configured global data structure (e.g., chain restaurants present in several countries/available all over the world) it will send a monitoring or announcing request that contains only the global ProSe Application ID. The monitoring UE can also send multiple ProSe Application IDs with different scope in the same request, but overall it should not be considered that one ProSe Application ID replaces the other.

## Annex C (Informative): Change history

Change history								
Date	TSG #	TSG Doc.	CR	Rev	Cat	Subject/Comment	Old	New
2014-02	SP-63	SP-140119	-	-	-	MCC Editorial Update for presentation to TSG SA for Approval	0.2.0	1.0.0
2014-02	SP-63	-	-	-	-	MCC Editorial update for publication after TSG SA approval	1.0.0	12.0.0
2014-06	SP-64	SP-140267	0002	2	F	ProSe Application ID Operator Identifier is changed to PLMN ID	12.0.0	12.1.0
2014-06	SP-64	SP-140267	0003	2	F	Application identity usage description	12.0.0	12.1.0
2014-06	SP-64	SP-140267	0004	2	F	Revocation of EPC assisted WLAN direct communication	12.0.0	12.1.0
2014-06	SP-64	SP-140267	0005	2	F	Change of Application Code in Discovery procedures	12.0.0	12.1.0
2014-06	SP-64	SP-140267	0009	2	F	Corrections in ProSe architecture description	12.0.0	12.1.0
2014-06	SP-64	SP-140267	0010	4	F	Corrections in the description of functional entities	12.0.0	12.1.0
2014-06	SP-64	SP-140267	0012	1	F	Corrections in "Authorization and provisioning for ProSe" clause	12.0.0	12.1.0
2014-06	SP-64	SP-140267	0016	5	F	Update the interface description	12.0.0	12.1.0
2014-06	SP-64	SP-140267	0018	7	F	Interaction between the ProSe and EPC procedure	12.0.0	12.1.0
2014-06	SP-64	SP-140267	0019	2	F	Modification of Assistance information for EPC assisted WLAN direct communication	12.0.0	12.1.0
2014-06	SP-64	SP-140267	0020	-	F	Clarification of the ProSe direct discovery procedure	12.0.0	12.1.0
2014-06	SP-64	SP-140267	0021	1	F	Correction discovery authorization in match procedure procedure	12.0.0	12.1.0
2014-06	SP-64	SP-140267	0023	5	F	Completion of definitions	12.0.0	12.1.0
2014-06	SP-64	SP-140267	0024	1	F	ProSe Application Code fix	12.0.0	12.1.0
2014-06	SP-64	SP-140267	0025	5	F	Clarification on authorization policy for ProSe Direct Discovery	12.0.0	12.1.0
2014-06	SP-64	SP-140267	0030	2	F	Corrections for clauses 5.3.3.4 and 5.3.3.5.	12.0.0	12.1.0
2014-06	SP-64	SP-140267	0034	1	F	Correction on Announcing procedures	12.0.0	12.1.0
2014-06	SP-64	SP-140266	0037	3	F	Clarification of MSISDN usage	12.0.0	12.1.0
2014-06	SP-64	SP-140266	0039	2	F	Monitored PLMN in the Match report procedure	12.0.0	12.1.0
2014-06	SP-64	SP-140266	0042	7	F	Correction to use of masks and filters	12.0.0	12.1.0
2014-06	SP-64	SP-140266	0044	2	F	Clarification regarding the Discovery Filter and Filter ID	12.0.0	12.1.0
2014-06	SP-64	SP-140266	0047	1	B	Add a note on status of Relay in Rel-12	12.0.0	12.1.0
2014-06	SP-64	SP-140266	0056	2	F	Update to PLMN list handling	12.0.0	12.1.0
2014-06	SP-64	SP-140297	0057	5	F	Merger of CRs S2-142274 (23.303 CR0057R4) and S2-141927 (23.303 CR0045R2) to resolve figure update clash	12.0.0	12.1.0
2014-06	SP-64	SP-140266	0058	2	F	Handling of invalid Proximity Request due to exceeding time window	12.0.0	12.1.0
2014-06	SP-64	SP-140266	0066	1	F	Clarification on the announcing authorisation policy	12.0.0	12.1.0
2014-06	SP-64	SP-140266	0068	3	F	Revocation Procedures for ProSe Direct Service	12.0.0	12.1.0
2014-06	SP-64	SP-140266	0073	3	F	Clarifications on the use of wild-carded ProSe App. IDs/ProSe App. Codes	12.0.0	12.1.0
2014-06	SP-64	SP-140266	0074	1	F	Completes the number of RAN and CT references	12.0.0	12.1.0
2014-06	SP-64	SP-140266	0076	2	F	Editorial corrections	12.0.0	12.1.0
2014-06	SP-64	SP-140266	0077	1	F	Clarification on ProSe Direct Discovery Procedures in Roaming Case	12.0.0	12.1.0
2014-06	SP-64	SP-140266	0085	2	F	Missing text on Layer-3 Protocol Data Unit Type	12.0.0	12.1.0
2014-06	SP-64	SP-140266	0086	2	F	Usage of Source Layer-2 ID and Destination Layer-2 ID	12.0.0	12.1.0
2014-06	SP-64	SP-140266	0087	1	F	Missing procedure on ProSe Application Code revocation	12.0.0	12.1.0
2014-09	SP-65	SP-140419	0067	1	F	ProSe Subscription Data Stored in HSS	12.1.0	12.2.0
2014-09	SP-65	SP-140419	0071	2	F	Update the Match Report Procedure	12.1.0	12.2.0
2014-09	SP-65	SP-140419	0079	3	F	Clarification on ProSe UE functionality	12.1.0	12.2.0
2014-09	SP-65	SP-140419	0095	1	F	Source Layer-2 ID assignment	12.1.0	12.2.0
2014-09	SP-65	SP-140419	0099	1	F	ProSe UE context handling clarification	12.1.0	12.2.0
2014-09	SP-65	SP-140419	0100	2	F	PLMN addition into PLMN list when subscription of UE updates	12.1.0	12.2.0
2014-09	SP-65	SP-140419	0101	-	F	PC6 and PC7 usage in match reports	12.1.0	12.2.0
2014-09	SP-65	SP-140419	0103	3	C	ProSe Authorization	12.1.0	12.2.0
2014-09	SP-65	SP-140419	0104	2	C	ProSe Proxy	12.1.0	12.2.0
2014-09	SP-65	SP-140419	0108	1	F	Clarification of usage of Application ID in ProSe direct Discovery	12.1.0	12.2.0
2014-09	SP-65	SP-140598	0102	6	F	Precedence of ProSe configuration information	12.1.0	12.2.0

---

## History

<b>Document history</b>		
V12.2.0	September 2014	Publication