

# ETSI TS 126 237 V8.0.0 (2009-01)

---

*Technical Specification*

**Universal Mobile Telecommunications System (UMTS);  
LTE;  
IMS based PSS and MBMS User Service;  
Protocols  
(3GPP TS 26.237 version 8.0.0 Release 8)**

---



---

Reference

DTS/TSGS-0426237v800

---

Keywords

LTE, UMTS

**ETSI**

650 Route des Lucioles  
F-06921 Sophia Antipolis Cedex - FRANCE

Tel.: +33 4 92 94 42 00 Fax: +33 4 93 65 47 16

Siret N° 348 623 562 00017 - NAF 742 C  
Association à but non lucratif enregistrée à la  
Sous-Préfecture de Grasse (06) N° 7803/88

---

**Important notice**

Individual copies of the present document can be downloaded from:

<http://www.etsi.org>

The present document may be made available in more than one electronic version or in print. In any case of existing or perceived difference in contents between such versions, the reference version is the Portable Document Format (PDF). In case of dispute, the reference shall be the printing on ETSI printers of the PDF version kept on a specific network drive within ETSI Secretariat.

Users of the present document should be aware that the document may be subject to revision or change of status. Information on the current status of this and other ETSI documents is available at

<http://portal.etsi.org/tb/status/status.asp>

If you find errors in the present document, please send your comment to one of the following services:

[http://portal.etsi.org/chaicor/ETSI\\_support.asp](http://portal.etsi.org/chaicor/ETSI_support.asp)

---

**Copyright Notification**

No part may be reproduced except as authorized by written permission.  
The copyright and the foregoing restriction extend to reproduction in all media.

© European Telecommunications Standards Institute 2009.  
All rights reserved.

**DECT**<sup>™</sup>, **PLUGTESTS**<sup>™</sup>, **UMTS**<sup>™</sup>, **TIPHON**<sup>™</sup>, the TIPHON logo and the ETSI logo are Trade Marks of ETSI registered for the benefit of its Members.

**3GPP**<sup>™</sup> is a Trade Mark of ETSI registered for the benefit of its Members and of the 3GPP Organizational Partners.

**LTE**<sup>™</sup> is a Trade Mark of ETSI currently being registered

for the benefit of its Members and of the 3GPP Organizational Partners.

**GSM**<sup>®</sup> and the GSM logo are Trade Marks registered and owned by the GSM Association.

---

## Intellectual Property Rights

IPRs essential or potentially essential to the present document may have been declared to ETSI. The information pertaining to these essential IPRs, if any, is publicly available for **ETSI members and non-members**, and can be found in ETSI SR 000 314: *"Intellectual Property Rights (IPRs); Essential, or potentially Essential, IPRs notified to ETSI in respect of ETSI standards"*, which is available from the ETSI Secretariat. Latest updates are available on the ETSI Web server (<http://webapp.etsi.org/IPR/home.asp>).

Pursuant to the ETSI IPR Policy, no investigation, including IPR searches, has been carried out by ETSI. No guarantee can be given as to the existence of other IPRs not referenced in ETSI SR 000 314 (or the updates on the ETSI Web server) which are, or may be, or may become, essential to the present document.

---

## Foreword

This Technical Specification (TS) has been produced by ETSI 3rd Generation Partnership Project (3GPP).

The present document may refer to technical specifications or reports using their 3GPP identities, UMTS identities or GSM identities. These should be interpreted as being references to the corresponding ETSI deliverables.

The cross reference between GSM, UMTS, 3GPP and ETSI identities can be found under <http://webapp.etsi.org/key/queryform.asp>.

# Contents

Intellectual Property Rights .....	2
Foreword.....	2
Foreword.....	6
Introduction .....	6
1 Scope .....	7
2 References .....	7
3 Definitions and abbreviations.....	8
3.1 Definitions .....	8
3.2 Abbreviations .....	9
4 System description .....	9
4.1 Introduction .....	9
4.2 Architecture .....	10
4.2.1 Non IMS 3GPP PSS and MBMS User Service architecture.....	10
4.2.2 IMS based PSS and MBMS User Service architecture .....	10
4.3 IMS based PSS and MBMS US procedures overview .....	13
4.4 PSS and MBMS user profile and UE capabilities .....	15
4.4.1 User profile description .....	15
4.4.2 UE capabilities.....	15
4.4.3 Storage location .....	15
5 Service Provider Discovery .....	16
5.1 Introduction .....	16
5.2 DNS .....	16
5.3 Others .....	16
6 User Service Discovery .....	17
6.1 Introduction .....	17
6.2 Subscribe/Notify.....	17
6.2.1 General description .....	17
6.2.2 Procedures at the UE.....	18
6.2.2.1 Introduction .....	18
6.2.2.2 Subscription .....	18
6.2.2.3 Receiving notifications.....	18
6.2.3 Procedures at the SDF.....	19
7 User Service Description retrieval .....	19
7.1 Introduction .....	19
7.2 User Service Description retrieval for PSS and MBMS.....	20
7.2.1 Procedures at the UE.....	20
7.2.1.1 Procedure for Service Personalisation.....	20
7.2.1.2 Request of OMA BCAST ESG.....	20
7.2.1.3 Use of Service Description information.....	20
7.2.2 Procedures at the SSF .....	20
7.2.2.1 Authentication and authorisation in case of personalized service description information.....	20
7.2.2.2 Procedure for Service Personalization .....	21
7.2.2.3 Delivery of OMA BCAST ESG.....	21
8 Streaming session and media control .....	21
8.1 General .....	21
8.2 PSS Streaming.....	21
8.2.1 PSS Media codecs and formats.....	21
8.2.2 Procedure for providing missing parameters before session initiation .....	21
8.2.2.1 Procedures at the UE.....	21
8.2.2.2 Procedures at the SCF .....	22

8.2.2.3	Procedures at the PSS Adapter.....	22
8.2.3	PSS Streaming Session initiation.....	22
8.2.3.1	General description.....	22
8.2.3.2	Procedures at the UE.....	23
8.2.3.3	Procedures at the IM CN Subsystem.....	24
8.2.3.4	Procedures at the SCF.....	24
8.2.3.5	Procedures at the PSS Adapter.....	24
8.2.4	PSS Streaming Playback Control.....	26
8.2.4.1	General Description.....	26
8.2.4.1	Procedures at the UE.....	26
8.2.4.2	Procedures at the PSS Adapter.....	27
8.2.4.3	Procedures at the PSS Server.....	27
8.2.5	PSS content switching.....	27
8.2.5.1	PSS Streaming session modification.....	27
8.2.5.1.1	General description.....	27
8.2.5.1.2	Procedures at the UE.....	28
8.2.5.1.3	Procedures at the IM CN subsystem.....	29
8.2.5.1.4	Procedures at the SCF.....	29
8.2.5.1.5	Procedures at the PSS adapter.....	29
8.2.5.1.6	Procedures at the PSS server.....	29
8.2.5.2	PSS Content switching with available SDP, no change of media component and bandwidth.....	29
8.2.5.2.1	General description.....	29
8.2.5.2.2	Procedures at the UE.....	31
8.2.5.2.3	Procedures at the IM CN Subsystem.....	31
8.2.5.2.4	Procedures at the SCF.....	31
8.2.5.2.5	Procedures at the PSS Adapter.....	31
8.2.5.2.6	Procedures at the PSS Server.....	31
8.2.5.3	PSS Content switching with available SDP, change of media components or QoS.....	31
8.2.5.3.1	General Description.....	31
8.2.5.3.2	Procedures at the UE.....	32
8.2.5.3.3	Procedures at the IM CN Subsystem.....	33
8.2.5.3.4	Procedures at the SCF.....	33
8.2.5.3.5	Procedures at the PSS Adapter.....	33
8.2.5.3.6	Procedures at the PSS Server.....	33
8.2.5.4	PSS Content switching with unavailable SDP, no change of media component and/or bandwidth.....	33
8.2.5.4.1	General description.....	33
8.2.5.4.2	Procedures at the UE.....	34
8.2.5.4.3	Procedures at the IM CN Subsystem.....	34
8.2.5.4.4	Procedures at the SCF.....	34
8.2.5.4.5	Procedures at the PSS Adapter.....	35
8.2.5.4.6	Procedures at the PSS Server.....	35
8.2.5.5	PSS Content switching with unavailable SDP, change of media component and/or bandwidth.....	35
8.2.5.5.1	General description.....	35
8.2.5.5.2	Procedures at the UE.....	36
8.2.5.5.3	Procedures at the IM CN Subsystem.....	36
8.2.5.5.4	Procedures at the SCF.....	36
8.2.5.5.5	Procedures at the PSS Adapter.....	37
8.2.5.5.6	Procedures at the PSS Server.....	37
8.2.6	PSS Streaming Session Teardown.....	37
8.2.6.1	General Description.....	37
8.2.6.2	Procedures at the UE.....	38
8.2.6.3	Procedures at the IM CN Subsystem.....	38
8.2.6.4	Procedures at the SCF.....	38
8.2.6.5	Procedures at the PSS Adapter.....	38
8.2.6.6	Procedures at the PSS Server.....	38
8.3	MBMS Streaming.....	38
8.3.1	MBMS Media codecs and formats.....	38
8.3.2	Procedure for providing missing parameters before session initiation.....	38
8.3.2.1	Procedures at the UE.....	38
8.3.2.2	Procedures at the SCF.....	39
8.3.3	MBMS Streaming Session initiation.....	39
8.3.3.1	General description.....	39

8.3.3.2	Procedures at the UE .....	39
8.3.3.3	Procedures at the IM CN Subsystem .....	40
8.3.3.4	Procedures at the SCF .....	40
8.3.3.5	Procedures at the BMSC.UPF .....	40
8.3.4	MBMS content switching .....	41
8.3.4.1	General Description .....	41
8.3.4.2	Procedures at the UE .....	41
8.3.4.2	Procedures at the IM CN Subsystem .....	41
8.3.4.3	Procedures at the SCF .....	42
8.3.4.4	Procedures at the BMSC.UPF .....	42
8.3.5	MBMS Streaming Session Teardown .....	42
8.3.5.1	General Description .....	42
8.3.5.2	Procedures at the UE .....	42
8.3.5.3	Procedures at the IM CN Subsystem .....	42
8.3.5.4	Procedures at the SCF .....	42
8.3.5.5	Procedures at the BMSC.UPF .....	43
8.4	Combined PSS and MBMS Streaming .....	43
8.4.1	Introduction .....	43
8.4.2	PSS - MBMS Switching .....	43
8.4.3	Switching from MBMS streaming to PSS streaming .....	43
8.4.3.1	Combined Session establishment .....	44
8.4.3.1.1	Procedures at the UE .....	44
8.4.3.1.2	Procedures at the IM CN Subsystem .....	44
8.4.3.1.3	Procedures at the SCF .....	44
8.4.3.1.4	Procedures at the PSS Adapter .....	45
8.4.3.1.5	Procedures at the PSS Server .....	45
8.4.3.2	Combined session teardown .....	45
8.4.4	Switching from PSS streaming to MBMS streaming .....	45
9	Policy and charging control .....	46
9.1	General .....	46
9.2	QoS control .....	46
10	Security Procedures .....	47
10.1	General .....	47
10.2	Secure Service Description Retrieval .....	48
10.3	PSS Authentication and Content encryption .....	49
10.4	MBMS Security procedures .....	49
<b>Annex A (normative):</b>	<b>3gpp_rtsp application .....</b>	<b>50</b>
<b>Annex B (informative):</b>	<b>Examples .....</b>	<b>51</b>
<b>Annex C (normative):</b>	<b>XML Schema for timer modification .....</b>	<b>52</b>
<b>Annex D (normative):</b>	<b>XML Schema for PSS and MBMS commands .....</b>	<b>53</b>
<b>Annex E (normative):</b>	<b>XML Schemas for the PSS content switch data .....</b>	<b>54</b>
<b>Annex F (normative):</b>	<b>XML Schemas for the MBMS content switch data .....</b>	<b>55</b>
<b>Annex G (normative):</b>	<b>XML Schema for PSS and MBMS UE Device Capabilities .....</b>	<b>56</b>
<b>Annex H (normative):</b>	<b>XML Schema for Service Attachment Information .....</b>	<b>57</b>
<b>Annex I (informative):</b>	<b>Change history .....</b>	<b>60</b>
History .....		61

---

## Foreword

This Technical Specification has been produced by the 3<sup>rd</sup> Generation Partnership Project (3GPP).

The contents of the present document are subject to continuing work within the TSG and may change following formal TSG approval. Should the TSG modify the contents of the present document, it will be re-released by the TSG with an identifying change of release date and an increase in version number as follows:

Version x.y.z

where:

- x the first digit:
  - 1 presented to TSG for information;
  - 2 presented to TSG for approval;
  - 3 or greater indicates TSG approved document under change control.
- y the second digit is incremented for all changes of substance, i.e. technical enhancements, corrections, updates, etc.
- z the third digit is incremented when editorial only changes have been incorporated in the document.

---

## Introduction

The 3GPP Packet Switch Streaming (PSS) provides a framework for Internet Protocol (IP) based streaming applications in by specifying protocols and codecs within the 3GPP system. Protocols for control signalling, capability exchange, media transport, rate adaptation and protection are specified. Codecs for speech, natural and synthetic audio, video, still images, bitmap graphics, vector graphics, timed text and text are specified.

The 3GPP Multimedia Broadcast and Multicast Service (MBMS) provides a framework for broadcast and Multicast streaming and download applications in 3GPP networks supporting the MBMS bearer service. The MBMS user services are enabled by a set of specified media codecs, formats and transport/application protocols. MBMS user services are built on top of the MBMS bearer service. There are two delivery methods for the MBMS user services: download and streaming.

The 3GPP IP Multimedia Subsystem (IMS) enables the deployment of IP multimedia applications. PSS and MBMS User Services are IP multimedia services but they were specified before IMS. IMS brings enablers and features to operators and subscribers that can enhance the experience of PSS and MBMS User Services.

The purpose of the present document is the specification of use of the IMS to initiate and control PSS and MBMS User Service. This should enable deployment of PSS and MBMS user services as IMS services. Note that the present specification uses components of the 3GPP PSS, 3GPP MBMS , ETSI TISPAN IPTV and Open IPTV Forum standards specifications.

---

# 1 Scope

The present document specifies the usage of IMS protocols to initiate and control PSS and MBMS Streaming User Services based applications. It applies to IMS enabled UEs that also implement PSS and/or MBMS clients. Existing protocols that are used are described in reference to relevant specifications. IMS based MBMS Download User Services are to be defined in a subsequent version of the present document.

The present document is applicable to IP-based packet-switched networks over 3GPP systems.

The present document includes information applicable to network operators, service providers and manufacturers

---

# 2 References

The following documents contain provisions which, through reference in this text, constitute provisions of the present document.

- References are either specific (identified by date of publication, edition number, version number, etc.) or non-specific.
- For a specific reference, subsequent revisions do not apply.
- For a non-specific reference, the latest version applies. In the case of a reference to a 3GPP document (including a GSM document), a non-specific reference implicitly refers to the latest version of that document *in the same Release as the present document*.

- [1] 3GPP TR 21.905: "Vocabulary for 3GPP Specifications".
- [2] 3GPP TS 22.146: "Multimedia Broadcast/Multicast Service; Stage 1".
- [3] 3GPP TS 22.246: "Multimedia Broadcast/Multicast Service (MBMS) user services; Stage 1".
- [4] 3GPP TS 23.246: "Multimedia Broadcast/Multicast Service (MBMS); Architecture and functional description".
- [5] 3GPP TS 33.246: "3G Security; Security of Multimedia Broadcast/Multicast Service (MBMS)".
- [6] 3GPP TS 23.228: "IP multimedia subsystem; Stage 2".
- [7] 3GPP TS 24.229: "IP multimedia call control protocol based on Session Initiation Protocol (SIP) and Session Description Protocol (SDP); Stage 3".
- [8] 3GPP TS 26.234: "Transparent end-to-end streaming service; Protocols and codecs".
- [9] 3GPP TS 22.233: "Transparent End-to-End Packet-switched Streaming Service; Stage 1".
- [10] 3GPP TS 26.233: "Transparent end-to-end packet switched streaming service (PSS); General description".
- [11] 3GPP TS 26.346: "Multimedia Broadcast/Multicast Service (MBMS); Protocols and codecs".
- [12] 3GPP TS 23.203: "Policy and charging control architecture".
- [13] IETF RFC 4145 (September 2005): "TCP-Based Media Transport in the Session Description Protocol (SDP)".
- [14] IETF RFC 4572 (July 2006) Connection-Oriented Media Transport over the Transport Layer Security (TLS) Protocol in the Session Description Protocol (SDP)
- [15] void
- [16] 3GPP TS 23.060: "General Packet Radio Service (GPRS); Service description; Stage 2".



- [17] IETF RFC 2782: "A DNS RR for specifying the location of services (DNS SRV)".
- [18] IETF draft-channabasappa-sipping-app-profile-type-03: "Extension to the ua-profile Event Package to Support the Application Profile Type". .
- [19] 3GPP TS 33.102: "3G security; Security architecture".
- [20] 3GPP TS 33.222: "Generic Authentication Architecture (GAA); Access to network application functions using Hypertext Transfer Protocol over Transport Layer Security (HTTPS)".
- [21] 3GPP TS 24.423: "TISPAN; PSTN/ISDN simulation services; Extensible Markup Language (XML) Configuration Access Protocol (XCAP) over the Ut interface for Manipulating NGN PSTN/ISDN Simulation Services".
- [22] 3GPP TS 24.109: "Bootstrapping interface (Ub) and network application function interface (Ua); Protocol details".
- [23] ETSI TS 182 027 "TISPAN; IPTV Architecture; IPTV functions supported by the IMS subsystem".
- [24] ETSI TS 183 063 "TISPAN; IMS based IPTV Stage 3 Specification".
- [25] IETF RFC 2326: "Real Time Streaming Protocol (RTSP)".
- [26] 3GPP TS 33.220: "Generic Authentication Architecture (GAA); Generic bootstrapping architecture".
- [27] OMA-TS-BCAST\_Service\_Guide-V1\_0: "Method and Apparatus for Broadcast Signaling in a Wireless Communication System".
- [28] IETF draft-ietf-sipping-config-framework-15: "A Framework for Session Initiation Protocol User Agent Profile Delivery".

NOTE: IETF drafts references need to be updated/confirmed when published.

---

## 3 Definitions and abbreviations

### 3.1 Definitions

For the purposes of the present document, the terms and definitions given in 3GPP TR 21.905 [1] and the following apply:

**On Demand:** users can select their required content, for example with the assistance of the Electronic Programme Guide (EPG), at the user preferred time.

NOTE: The content is then transmitted uniquely (unicast) to that consumer who can usually use trick-modes functionalities to control their viewing of the content. e.g. TV Content on Demand (CoD)

**IMS registration:** registration procedure for a public user identity initiated by the UE in the absence of any valid registration

**Live:** content is streamed and intended for reception by anyone where the consumer has no control over the content or timing of what he receives, apart from the ability to select a particular channel. e.g. linear TV.

**"Non-IMS" BM-SC:** BM-SC function as defined in 3GPP TS 23.246 [5] and 3GPP TS 26.346 [11] without any IMS support

**Multimedia Broadcast/Multicast Service (MBMS):** See 3GPP TS 22.146 [2].

**MBMS User Services:** MBMS User Service may use more than one Multimedia Broadcast/Multicast Service (bearer service) and more than one Broadcast and/or Multicast session (See 3GPP TS 22.246 [3].)

**MBMS user service discovery/announcement:** user service discovery refers to methods for the UE to obtain the list of available MBMS user services along with information on the user service and the user service announcement refers to methods for the MBMS service provider to make the list of available MBMS user services along with information on the user service available to the UE

**MBMS delivery method:** mechanism used by a MBMS user service to deliver content  
An MBMS delivery method uses MBMS bearers in delivering content and may make use of associated procedures.

**MBMS download delivery method:** delivery of discrete objects (e.g. files) by means of a MBMS download session

**MBMS streaming delivery method:** delivery of continuous media (e.g. real-time video) by means of a MBMS streaming session

**MBMS streaming session:** time, protocols and protocol state (i.e. parameters) which define sender and receiver configuration for the streaming of content

**PSS client:** client for the 3GPP packet switched streaming service based on the IETF RTSP/SDP and/or HTTP standards, with possible additional 3GPP requirements according to the present document

**PSS server:** server for the 3GPP packet switched streaming service based on the IETF RTSP/SDP and/or HTTP standards, with possible additional 3GPP requirements according to the present document

**Trick Play:** streaming playback mode during which the user can control playback by playing, seeking, pausing, fast forwarding and fast rewinding

## 3.2 Abbreviations

For the purposes of the present document, the abbreviations given in 3GPP TR 21.905 [1] and the following apply:

BM-SC	Broadcast-Multicast - Service Centre
ESG	Electronic Service Guide
GGSN	Gateway GPRS Serving Node
IMPI	IMS Private Identity
IMPU	IMS Public Identity
IMS	IP Multimedia Subsystem
IP	Internet Protocol
MBMS	Multimedia Broadcast/Multicast Service
PSS	Packet Switch Streaming
PSI	Public Service Identity
RTP	Real-Time transport Protocol
RTSP	Real-Time Streaming Protocol
SDP	Session Description Protocol
UE	User Equipment
URI	Uniform Resource Identifier
USD	User Service Description

---

## 4 System description

### 4.1 Introduction

This clause describes the IMS initiated and controlled PSS and MBMS User Service system. It gives a description of the architecture, the role of each new and modified entity and interface.

The description of the PSS system is in 3GPP TS 22.233 [9] and 3GPP TS 26.233 [10]. The description of the MBMS system is in 3GPP TS 23.246 [4].

## 4.2 Architecture

### 4.2.1 Non IMS 3GPP PSS and MBMS User Service architecture

Figure 1 describes the Non IMS PSS and MBMS User Service architecture.

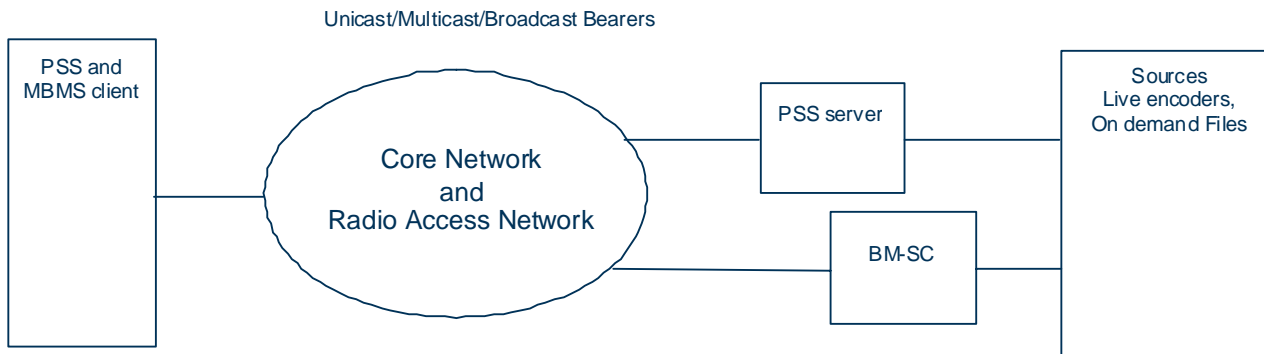

**Figure 1: Non IMS PSS and MBMS User Service Architecture**

The sources consist of all multimedia content in streaming or file form. E.g. live encoders processing in feeds from TV or Music Radio channels.

The PSS server performs control and streaming delivery functions on a Unicast access type.

The BM-SC performs control and streaming/download delivery functions in a hybrid Unicast/Multicast/Broadcast access type.

The core network and RAN enable the mobility, and provides IP connectivity over Unicast/Multicast/Broadcast bearers between the servers and the clients.

The PSS & MBMS client, located in the UE, performs service selection and initiation, receives and present the content to the user.

The PSS client interfaces to the PSS server transparently through the Packet Switch Network. The PSS client can discover the PSS services via multiple means like e.g. browsing. The session description protocol is SDP. The session control protocol is RTSP. The transport protocol is RTP.

The MBMS client interfaces to the BM-SC via layer 3 protocols defined between the UE and the GGSN and the GGSN with the BM-SC (Gmb).

The PSS and MBMS client interfaces via the Radio interface to the RAN and the CN.

The interface between the sources and the PSS server & BM-SC are outside the scope of the present document.

### 4.2.2 IMS based PSS and MBMS User Service architecture

Figure 2 describes the IMS based PSS and MBMS User Service functional architecture. In addition to PSS and MBMS User Service functions, the IMS core and various functions are added.

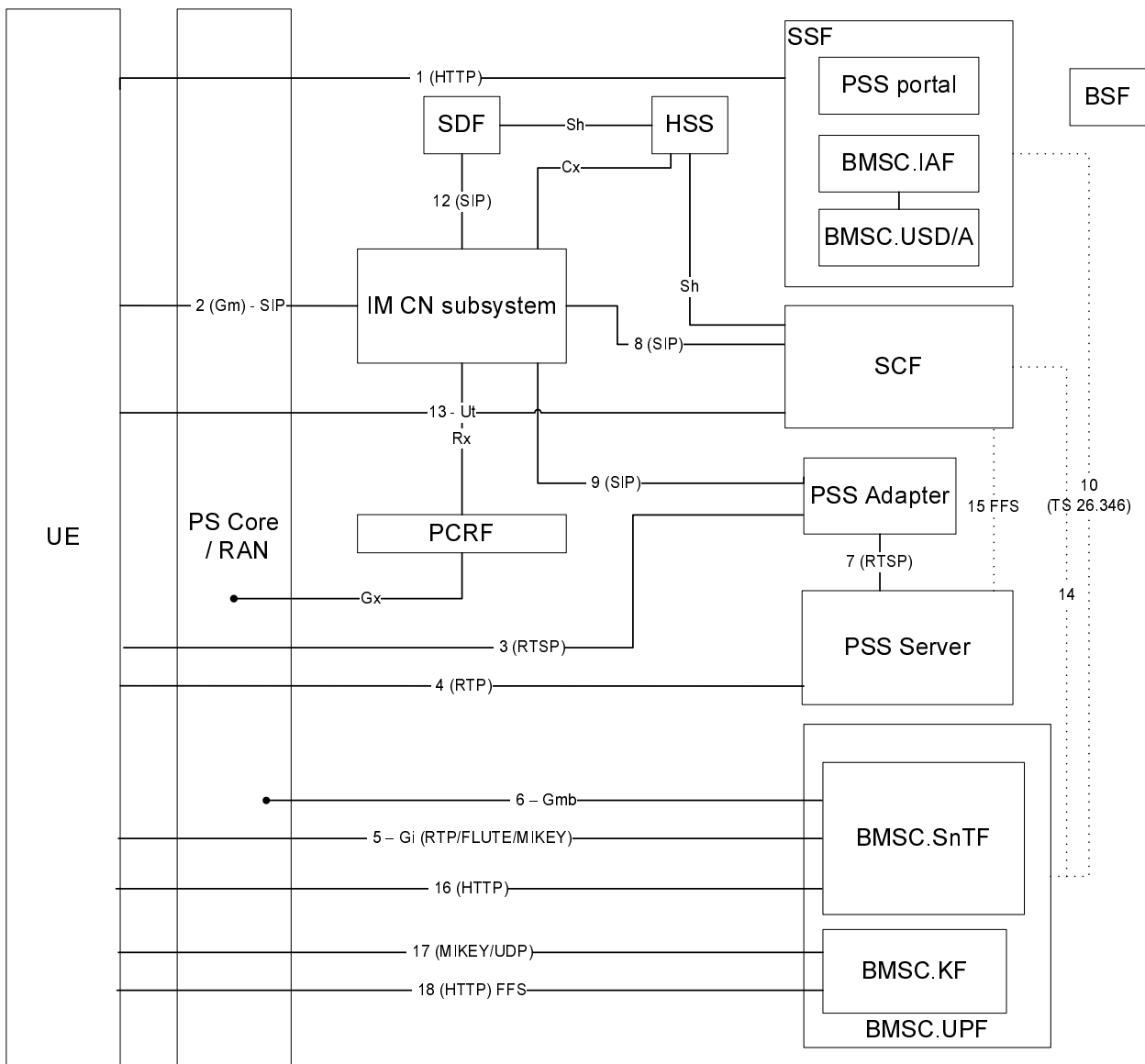

**Figure 2: IMS based PSS and MBMS functional architecture**

In figure 2:

- Solid lines are standard interfaces. E.g. interface 4.
- Dotted lines are for interfaces for which the protocols in use is out of the scope of the present document. E.g interface 10.

Description of functional entities:

- **IM CN Subsystem:** IMS Core Network Subsystem as defined in 3GPP TS 23.228 [6].The IM CN Subsystem supports, user registration and authentication, mobility and roaming, control of multimedia sessions, QoS control, Policy control, charging and interworking with circuit switched.
- **PS Core/RAN:** Packet Switch Core Network and Radio Access Network. See 3GPP TS 23.060.
- **UE:** The UE contains an GBA/IMS/PSS/MBMS client, which performs service discovery and selection,, handles service initiation, modification and termination, receives and present the content to the user. In addition to the procedures specified in this document, the UE shall support the procedures specified in 3GPP TS 24.229 [7] for the UE functional entity.

- SDF: Service Discovery Function (SDF): this function provides an entry point to SSF for the client to attach to the service provided by the service provider. In addition to the procedures specified in this document, the SDF shall support the procedures specified in 3GPP TS 24.229 [7] for the terminating UA functional entity.
- SSF: Service Selection Function (SSF): this function provides a list of available PSS and MBMS User Services and relevant User Service Description information. It can be personalized to the client's identity. The SSF shall support Service Announcement functions according to the Xa interface in TISpan. The PSS portal is for formatting and delivery of PSS Service Description information. The BMSC.IAF and BMSC.USD/A functions are according to 3GPP TS 26.346 [11]. The interface between BMSC.IAF and UE is according to 3GPP TS 26.346 [11] and out of the scope of the present specification. If the User Service Description information exists in a BMSC.USD/A of a "Non-IMS" BM-SC, or in a PSS portal, the SSF takes USD information from them. The SSF may then reformat the USD information before delivery to the UE. The reformat may include information for the IMS UE to build a SIP URI to initiate PSS and MBMS user service.
- SCF: Service Control Function (SCF): it provides service logic and functions required to support execution of such logic. It does service authorization during session initiation and session modification, which includes checking PSS and MBMS user's service subscription in order to allow or deny access to the service. It selects the relevant PSS and MBMS media functions. In addition to the procedures specified in this document, the SCF shall support the procedures specified in 3GPP TS 24.229 [7]:
  - For PSS, the SCF acts as a proxy or B2BUA.
  - For MBMS, the SCF acts as a terminating UA.
- BSF: Bootstrapping Server Function (BSF) as defined in 3GPP TS 33.220 [26] to perform GBA/GAA procedures with the UE.
- HSS: Home Subscriber Server as defined in 3GPP TS 23.002. Contains the IMS User Profile. It also may contain PSS and MBMS User Service specific User and UE data.
- PSS Adapter: this function performs bi-directional protocol translation between SIP and RTSP to offer control of PSS servers as defined in clause 8.2.3.5. It proxies RTSP messaging from the UE and SIP/RTSP translation towards the PSS server. Note that these functions can be incorporated into the SCF, the PSS Server or a new stand-alone entity. In addition to the procedures specified in this document, the PSS Adapter shall support the procedures specified in 3GPP TS 24.229 [7] for the terminating UA functional entity.
- PCRF: Policy and Charging Rules Function (3GPP TS 23.203 [12]). This function controls the charging and the establishment of resources in the RAN and PS core network.
- PSS Server: Packet Switch Streaming server function as described in 3GPP TS 26.234 [8]. It functionally contains media control and media delivery functions.
- BMSC.UPF: it contains all BMSC User Plane sub-functions.

NOTE: The BM-SC Membership function and Proxy and Transport function are defined in 3GPP TS 23.246 [4]. These functions are not described on the architecture in figure 2. The BM-SC Membership function is invoked for the establishment and release of Multicast bearers.

#### Description of interfaces:

- 1) This interface between the UE and the SSF is used to retrieve service selection information. It is based on HTTP.
- 2) Gm: This is a SIP based interface between the UE (IMS Client) and the P-CSCF. It is used to forward the SIP service request and response between UE and network.
- 3) This RTSP based interface between the UE (PSS Client) and the PSS Adapter allows media flow control.
- 4) This interface between the PSS Server and the UE is for delivery of streaming data. It is based on RTP and RTCP protocol.
- 5) This interface between the BMSC.UPF and the UE is for delivery of streaming data and traffic keys. It is based on (S)RTP, FLUTE and MIKEY protocols.
- 6) Gmb: This interface sits between the BMSC.UPF and the GGSN. The Gmb interface is defined in 3GPP TS 23.246 [4].

- 7) This interface between the PSS Adapter and the PSS Server allows control of the PSS Server. This interface is based on RTSP.
- 8) This interface between the IM CN subsystem and the SCF is an ISC (IMS Service Control) interface based on SIP.
- 9) This is a SIP interface between the IM CN subsystem and the PSS adapter. The interfaces 8 and 9 are used to setup, modify and teardown PSS sessions.

NOTE: Under certain conditions this interface between the SCF and the PSS adapter can be implemented as a direct interface (i.e. not going via the IM CN subsystem).

- 10) This interface between the SSF and the BMSC.UPF is according to 3GPP TS 26.346 [11]. It may be used to carry USD over MBMS bearers.
- 11) Void.
- 12) This is an ISC interface between the SDF and the IM CN subsystem.
- 13) This interface between the UE and SCF is used for PSS and MBMS User Service and User Profile configuration. It is equivalent to the Ut interface in TISPAN IPTV.
- 14) This interface between the SCF and the BMSC.UPF is used for security related functions and is FFS.
- 15) This interface between the SCF and the PSS Server is FFS.
- 16) This interface between the UE to the BMSC.SnTF is used for MBMS Associated Delivery procedures as defined in 3GPP TS 26.346 [11].
- 17) This interface between the UE and the BMSC.KF is used for delivery of the MSK as defined in 3GPP TS 26.346 [11].
- 18) This interface between the UE and the BMSC.KF is used for Key Request Functions and is FFS.

### 4.3 IMS based PSS and MBMS US procedures overview

Figure 3 describes the IMS based PSS and MBMS procedures from connection establishment to User Service Description retrieval.

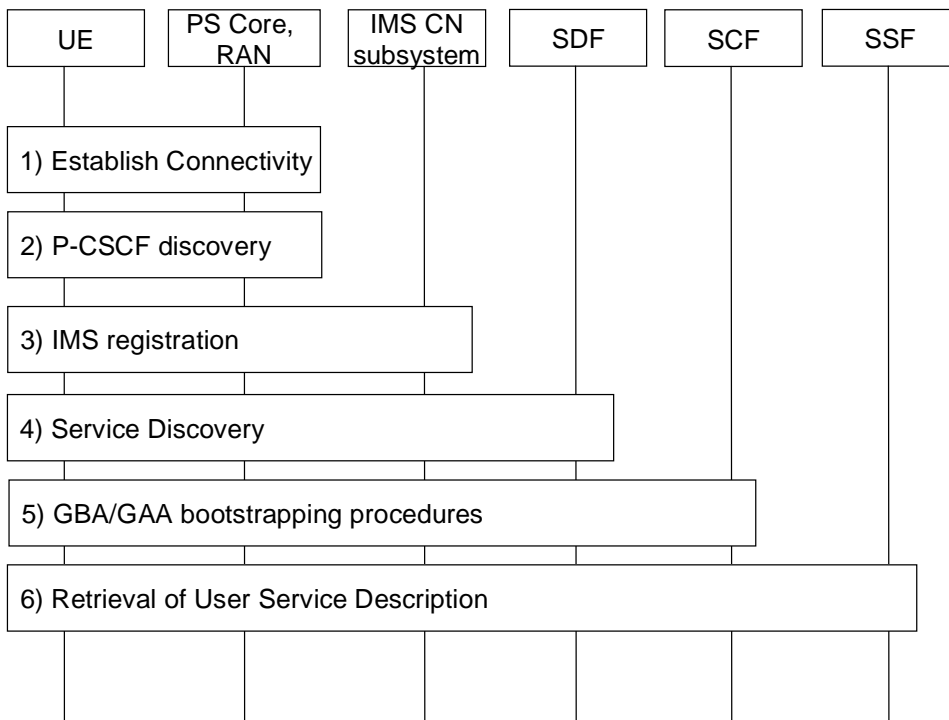

**Figure 3 : Procedures overview - part 1**

- Step 1 to 3: are outside the scope of the present document.
- Step 4: Service discovery, allows the Client to be informed of the available Service Providers.
- Step 5: GBA/GAA bootstrapping procedures, authenticates the User for signalling outside IMS and generates the Long Term Key that will be used during content key management procedures.
- Step 6: Retrieval of User Service description, allows the client to obtain the service session information for the selected provider.

Figure 4 describes the IMS based PSS and MBMS procedures from session establishment to content key management.

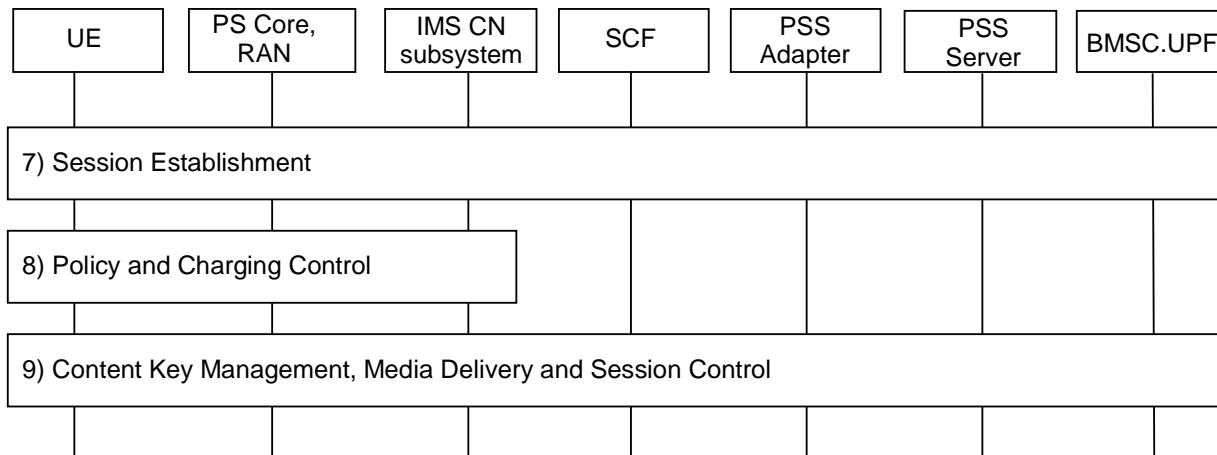

**Figure 4 : Procedures overview - part 2**

- Step 7: Session Establishment, allows the Client to initiate a PSS or MBMS User Service session to receive content.
- Step 8: Policy and Charging Control, are procedures performed via the IMS core to setup relevant bearer QoS and charging functions.

Step 9: Content Key Management is necessary to generate and distribute the keys to allow secure delivery of content to the User. At this stage, the delivery session is established and content is delivered to the client.

## 4.4 PSS and MBMS user profile and UE capabilities

### 4.4.1 User profile description

The PSS and MBMS user profile data contains all information required to operate PSS and MBMS user services.

The part of the PSS & MBMS user profile used for On Demand (CoD in TISPAN) and Live (BC in TISPAN) services shall be as defined in TISPAN TS 183 063, Annex C.

### 4.4.2 UE capabilities

A set of PSS and MBMS UE capabilities is required to personalize and operate PSS and MBMS user services. These capabilities are described in 2 documents:

- The PSS and MBMS UE Capabilities XML document defined in Annex G.
- The RDF/XML document for the PSS base vocabulary specified in Annex F of TS 26.234 [8].

These 2 documents are sent during the Service Discovery procedure. See clause 6.

### 4.4.3 Storage location

PSS and MBMS user profile and UE capabilities information may be stored in the following locations:

- Application Server functions.
- In a stand-alone server associated with one or more Application Server functions.
- In the HSS as transparent data associated to these Application Server functions.

The first and second options are recommended for data to be accessed by 3rd party application server functions. In the first and second case the Application Server function or the stand-alone server may exhibit the behaviour of an XDMS.

User data stored in the HSS can be accessed by Application Servers at the Sh reference point.

A subset of PSS and MBMS user-profile information may be accessed from the User Equipment at the Ut reference point.

For the purpose of personalized service selection, the SSF may need to access user data.

In the case when such user data is stored in the HSS, it can be accessed by the SSF at the Sh reference point when the SSF is in the same domain.

On the contrary, when such user data is stored in the AS or in a stand alone server associated with one or more application servers or if the SSF is not in the same domain as the HSS, the user data can be accessed by the SSF using an interface that is out of scope for this release.

The SSF may also request notification of user data updates.



## 5 Service Provider Discovery

### 5.1 Introduction

In order for the UE to access the PSS and MBMS User Service using IMS, it shall implement an IMS client that registers to the IM CN Subsystem [7]. This assumes that the UE has attached to a network and established PS connectivity through a PDP context according to 3GPP TS 23.060 [16] and has successfully completed the P-CSCF discovery procedure [7]. Once the UE is registered to the IM CN Subsystem, it can proceed to the Discovery of the PSS and MBMS User Service.

This clause specifies how the UE performs the PSS and MBMS Service Provider Discovery. This is equivalent to discovering the list of IMS PSI of the SDF and relative Service Providers. There are several means for the UE to acquire this information. The UE shall implement the DNS based Service Provider Discovery as defined in clause 5.2. Other methods are optional.

### 5.2 DNS

In this case, the SDFs are discovered using the DNS SRV mechanism in accordance with RFC 2782 [17], with the following input parameters:

- Service: Defined as "pss-mbms-user-service".

NOTE: to be registered with IANA.

- Protocol: Can take values "http" or "sip". Specifies the protocol to contain the particular service.
- Domain name: the domain for which the returned records are valid; the value can be derived from the following:
  - Domain from manual configuration.
  - Domain from network attachment phase (DHCP server).
  - Domain from IMS home domain.

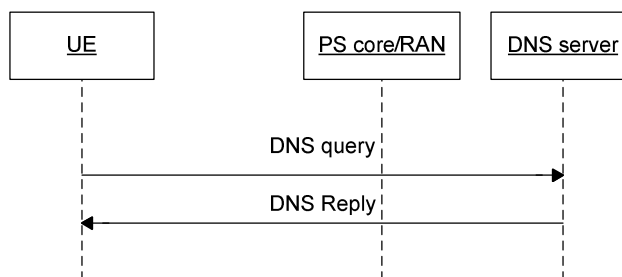

**Figure 5: Service Provider Discovery with DNS**

The output of the DNS SRV lookup is an ordered list of domain name, each pointing to a SDF server available within the specified Domain name.

### 5.3 Others

Alternatively, the SDF PSI may also be signalled to the UE by the following means:

- Manually provisioned in the UE.
- OMA Device Management.
- SMS.

- OMA Push.
- MBMS.
- DHCP.

## 6 User Service Discovery

### 6.1 Introduction

This clause specifies how the UE performs the PSS and MBMS User Service Discovery. This is equivalent to discovering the address of the SSF.

### 6.2 Subscribe/Notify

#### 6.2.1 General description

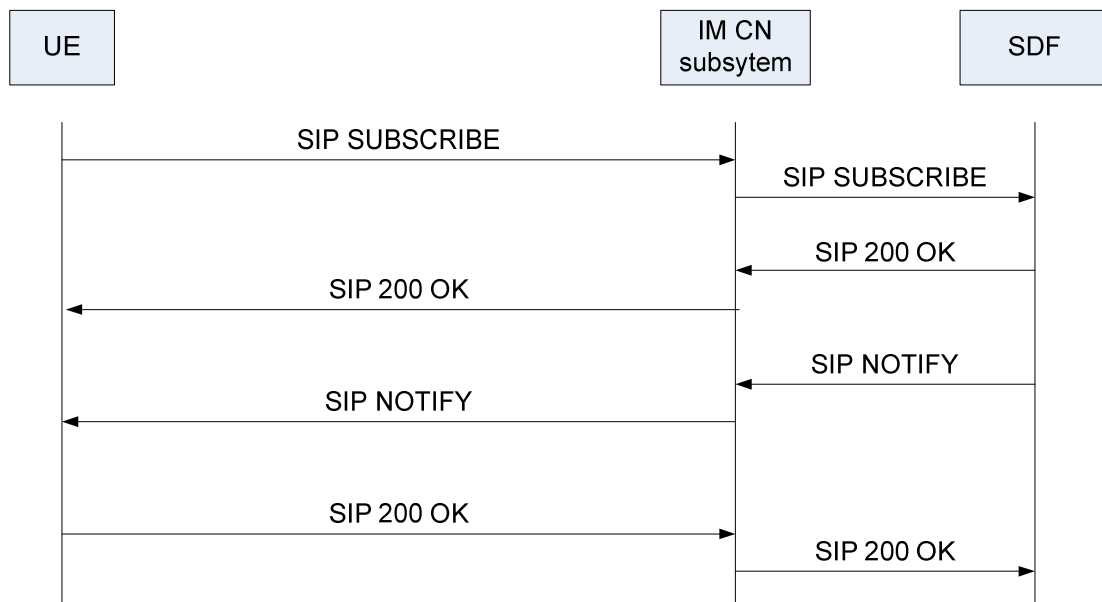

**Figure 6: Service Discovery with Subscribe/Notify**

- 1) The UE sends a SIP SUBSCRIBE message to the IM CN subsystem. It should indicate its capabilities in the message.
- 2) The IM CN subsystem forwards the request to the SDF, e.g. thanks to an iFC.
- 3) The SDF determines the proper service discovery information, e.g. according to the UE capabilities, the user's profile (Personalized Service Discovery). The user profile may be retrieved from the HSS or any other entity where it is stored.
- 4) The SDF sends a SIP 200 OK response to the IM CN subsystem, which forwards it to the UE.
- 5) The SDF sends a SIP NOTIFY message to the UE, with service discovery information that includes the SSF(s) address(es).
- 6) The IM CN subsystem relays the SIP NOTIFY message back to the UE, with the service discovery information related to PSS and MBMS user service.
- 7) The UE sends back a SIP 200 OK response to the IM CN subsystem.

8) The IM CN subsystem forwards the SIP 200 OK to the SDF.

## 6.2.2 Procedures at the UE

### 6.2.2.1 Introduction

The UE shall generate a SUBSCRIBE request. The behaviour of the UE when processing a SUBSCRIBE request shall conform to 3GPP TS 24.229 [7].

### 6.2.2.2 Subscription

When the UE intends to retrieve service attachment information from the SDF, it shall generate a SUBSCRIBE request for the "ua-profile" event package defined in [28] and extended as described in [18].

The contents of the SUBSCRIBE request shall be as follows:

- The value of the Request-URI shall be set to one of following:
  - the PSI of the SDF which is retrieved using SDF Discovery procedures in clause 5 Service Provider Discovery; or
  - the public user identity of the end user (when the UE does not know the PSI of the SDF).
- The From and To header shall be set to the public user identity of the user.
- The Accept header shall include the content-type identifier that corresponds to the registered MIME type of XML documents representing UE capabilities included in the body, See clause 4.4.2:
  - A first Content Type set to "application/3gpp-ims-pss-mbms-ue-capabilities+xml".
  - A second Content Type set to "application/rdf+xml".
- The Event header shall be set to the "ua-profile" event package.
- The Event parameters shall be set as follows:
  - The "profile-type" parameter shall be set to "application".
  - The "vendor", "model" and "version" parameter values shall be set to values specified by the implementer of the user equipment, as specified in 3GPP TS 24.229 [7].
  - The "appids" parameter shall be present and set to "urn:org:3gpp:applications:ims-pss-mbms-service-discovery".

The UE shall include a SIP SUBSCRIBE multipart/mixed content-type message body associated with the appid including the PSS and MBMS UE Device Capabilities defined in Annex G and the RDF/XML document describing the PSS base vocabulary defined in Annex F of TS 26.234 [8].

Upon receipt of a 2xx response to the SUBSCRIBE request, the UE shall store the information for the established dialog and the expiration time as indicated in the Expires header of the received response.

The UE shall automatically refresh the subscription, either 600 seconds before the expiration time if the initial subscription was for greater than 1 200 seconds, or when half of the time has expired if the initial subscription was for 1 200 seconds or less. If a SUBSCRIBE request to refresh a subscription fails with a non-481 response, the UE shall still consider the original subscription valid for the duration of the most recently known "Expires" value according to 3GPP TS 24.229 [7]. Otherwise, the UE shall consider the subscription invalid and start a new initial subscription according to 3GPP TS 24.229 [7].

### 6.2.2.3 Receiving notifications

Upon receipt of a NOTIFY request on the dialog which was generated during subscription, the application within the UE shall parse the XML document contained in the message body. The XML document schema is defined in Annex H.

The list of parameters in the XML document shall be used for service selection information retrieval according to clause 7.

After all elements have been processed, the UE shall return a 200 OK response to the NOTIFY request.

Failure to perform subscription refresh does not imply that there is a loss of communication to SSF or SCF. The UE has an option to continue using the lists of parameters from the last NOTIFY.

After deregistration, the UE may keep stored information on per user basis. As for subscription refresh, the UE may use the stored information if initial subscription fails after a new registration.

### 6.2.3 Procedures at the SDF

The SDF addresses are determined by the UE using any of the alternatives as defined in clause 5.

When the SDF receives a SUBSCRIBE request, it may perform user's identity verification as defined in 3GPP TS 24.229 [7]. After successful user identification, if a User Profile is available it is possible to perform personalization of the body (Service Attachment Information) of the NOTIFY request.

The SDF shall examine the parameters specified in the SIP SUBSCRIBE body and shall then record UE capabilities information as part of the user profile data.

**NOTE:** The UE capabilities that are recorded as part of the user profile may be used by the SSF for personalization purposes.

In case of successful subscription, the SDF shall generate a SIP 200 OK in response to the SUBSCRIBE request. The SDF shall then send a NOTIFY request immediately.

The contents of the NOTIFY request shall be as follows:

- The Event header shall be set to the "ua-profile" event package.
- The "effective-by" parameter for the event header shall be set to 0.
- The content type shall be set to "application/3gpp-ims-pss-mbms-service-discovery+xml";
- The message body shall contain an XML document listing SSF addresses and the means of connecting to the SSFs for retrieving service selection information defined in Annex H. The "@technology" element name indicates the technology used to for delivering service selection information. It shall be set to the "openmobilealliance.org\_bcast".

---

## 7 User Service Description retrieval

### 7.1 Introduction

User Service Description retrieval can be done in several ways

- By retrieving OMA BCAST Service Guide information [27] from the SSF. See clause 7.2.
- By retrieving MBMS USD from the SSF as defined in 3GPP TS 26.346 [11] clause 5.2
- By executing the Procedure for providing missing parameters before session initiation described in clauses 8.2.2 and 8.3.2

## 7.2 User Service Description retrieval for PSS and MBMS

### 7.2.1 Procedures at the UE

#### 7.2.1.1 Procedure for Service Personalisation

For HTTP-based data retrieval, when sending the HTTP request to the SSFs, the UE may provide personalized information to enable a personalized answer. This shall be done by adding the X-3GPP-Intended-Identity HTTP header to the request to transmit the public identity.

The authentication shall follow 3GPP TS 33.102 [19], and may be performed either using the mechanisms specified in 3GPP TS 33.222 [20] or HTTP Digest access authentication, as described in 3GPP TS 24.229 [7].

The UE shall implement Transport Layer Security (TLS), as described in RFC 2246 [36].

#### 7.2.1.2 Request of OMA BCAST ESG

In the pull model of unicast delivery of an OMA BCAST ESG, the HTTP protocol shall be used conforming to OMA TS-BCAST\_Service\_Guide [27], clause 5.4.3.

#### 7.2.1.3 Use of Service Description information

The UE shall use parameters received from the SSF for session initiation.

NOTE: There is no restriction on the UE to use any parameter received from SSF also for other purposes than session initiation, e.g. to present SSF information to the user.

The UE may store a part of the ESG information covering certain period of time and refresh this information periodically. This avoids the UE to contact the SSF every time the user needs to consult the ESG.

If the UE is unable to contact any discovered SSF, it shall not delete stored information immediately.

### 7.2.2 Procedures at the SSF

#### 7.2.2.1 Authentication and authorisation in case of personalized service description information

In case of service selection personalisation the SSF shall authenticate the user.

The authentication shall follow TS 33.102 [19], and may be performed either using the mechanisms specified in 3GPP TS 33.222 [20] or HTTP Digest access authentication as described in 3GPP TS 24.229 [7].

The SSF shall implement Transport Layer Security (TLS) as described in RFC 2246 [36].

An authentication proxy (AP) may exist between the UE and the SSF in which case the behaviour of the AP is assumed to conform to 3GPP TS 24.423 [21].

If an Authentication Proxy (AP) is provided in the path of the HTTP request, then the SSF receives an HTTP request from a trusted source (the AP) and the request contains an HTTP X-3GPP-Asserted-Identity header (3GPP TS 24.109 [22]) that includes an asserted identity of the user. In this case the SSF does not need to authenticate the user, but just provide authorization to access the requested resource.

If an HTTP X-3GPP-Asserted-Identity header (3GPP TS 24.109 [22]) is not present in the HTTP request or if the request is received from a non-trusted source, then the SSF needs to authenticate the user prior to providing personalised information by applying the following procedures:

On receiving an HTTP request that does not contain an Authorization header the SSF shall:

- a) challenge the user by generating a 401 Unauthorized response that contains the proper Digest authentication parameters (e.g. realm), according to 3GPP TS 24.229 [7]. Provisioning of credentials to authenticate the user is outside the scope of the present document; and

- b) forward the 401 Unauthorized response to the sender of the HTTP request.

On receiving an HTTP request that contains an Authorization header, the SSF shall:

- a) apply the authentication procedures defined in 3GPP TS 24.229 [7]; and
- b) authorize or deny authorization depending on the authenticated identity.

### 7.2.2.2 Procedure for Service Personalization

If the public user identity information is present in the query from the UE, the SSF shall extract it to customize/personalize the service information that is returned in the query response.

The SSF shall use the public user identity that is specified in the X-3GPP-Intended-Identity header or the X-3GPPAsserted-Identity header if an authentication proxy is used to fetch the corresponding user profile associated with the user. For instance, the Parental Control (if present) should be used to remove unsuitable elements from the COD listings that are returned to the UE.

### 7.2.2.3 Delivery of OMA BCAST ESG

The procedure for retrieving OMA BCAST service selection information is employed to retrieve one or more Service Guide Delivery Descriptors (SGDD) and/or Service Guide Delivery Units (SGDU). The SGDD describes service level information as well as access information to the Service Guide fragments. The SGDU is the transport-independent network structure for encapsulating Service Guide fragments.

When the ESG SSF receives a HTTP POST request, if personalization headers are presents (in the form of key-value pairs) it shall use those headers in order to build a personalized response. For instance, the ESG SSF may use the provided user identity to retrieve the associated Parental Control Level in the user profile. This Parental Control Level would then be used to remove non suitable elements from the ESG data that are sent back. The provided user identity may also be used to retrieve a personalized ESG using the method in OMA-TS-BCAST\_Service\_Guide-V1\_0 [27], clause 5.4.3.3. The ESG SSF shall send an HTTP response conforming to OMA-TS-BCAST\_Service\_Guide-V1\_0 [27], clause 5.4.3.1. The body of the HTTP response shall contain an XML document with SGResponse data, conforming to OMA-TS-BCAST\_Service\_Guide-V1\_0 [27], clause 5.4.3.1.1.

---

## 8 Streaming session and media control

### 8.1 General

This clause specifies the procedures and protocols used for the IMS based initiation and control of streaming sessions on PSS or MBMS User Service.

The client shall use SIP to initiate and control PSS and MBMS streaming sessions. Once a PSS streaming session is established, the client shall use PSS (RTSP) protocols to perform media control.

### 8.2 PSS Streaming

#### 8.2.1 PSS Media codecs and formats

PSS Media codecs and formats defined in 3GPP TS 26.234 [8] are applicable to the present document for IMS initiated and controlled PSS services.

#### 8.2.2 Procedure for providing missing parameters before session initiation

##### 8.2.2.1 Procedures at the UE

If the UE does not have all the information it needs to form an SDP offer, the UE shall send a SIP OPTIONS message:

- The "Request-URI" is related to the PSS session that the user wants to activate. The Request-URI shall be composed of a user and domain part as defined as follows:
  - The user part contains the content identifier, retrieved from user service description information from SSF.
  - The domain part is the Service Provider domain name, obtained from SSF.
- The TO header shall contain the same URI as in the "Request-URI" parameter.
- The FROM header shall indicate the public user identity of the user.

Upon reception of the 200 OK including SDP, the UE shall initiate PSS session as described in clause 8.2.3.

### 8.2.2.2 Procedures at the SCF

When receiving the SIP OPTIONS message, the SCF shall select the appropriate PSS Adapter and forward the SIP request to the appropriate PSS Adapter by changing the "Request-URI" accordingly.

The SCF shall not change the user-part of the TO header in order to keep the content-id in the OPTIONS request.

### 8.2.2.3 Procedures at the PSS Adapter

When receiving SIP OPTIONS request, the PSS Adapter shall examine the On Demand content identifier present in the user-part of the TO header.

The PSS Adapter shall answer with the user service description information of the content delivery channel in SDP as requested by the request URI.

## 8.2.3 PSS Streaming Session initiation

### 8.2.3.1 General description

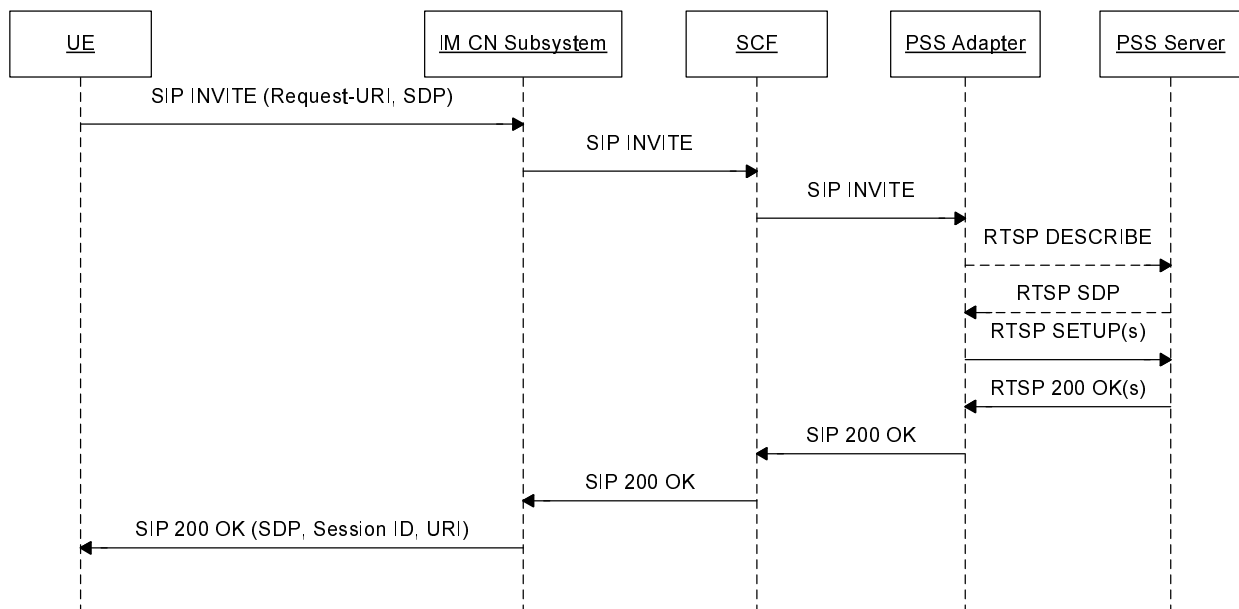

**Figure 7: IMS based PSS initiation**

NOTE 1: This sequence is simplified and does not e.g. show session progress messages and the ACK message from the UE in response to the reception of 200 OK.

NOTE 2: SIP messages between PSS adapter and SCF go through the IM CN Subsystem even if not indicated on the sequences.

### 8.2.3.2 Procedures at the UE

The UE shall generate an initial INVITE request:

- The Request-URI is related to the PSS session that the user wants to activate.
  - For an On Demand service, it shall be composed of a user part and a domain part, as follows:
    - A user part containing the content identifier in a free string format.
    - A domain part containing the content provider domain name, obtained from the SSF.
  - For Live content, it shall contain the PSI (Public Service Identity) of the "Live stream".
- The To header shall contain the same URI as in the Request-URI.
- The From header shall indicate the public user identity of the user.

An SDP Offer shall be included in the initial INVITE request, in accordance with media capabilities and policies available for the PSS session and with the parameters received from the SSF during service selection procedure.

The SDP offer shall contain a media description for the RTSP content control channel and one for the content delivery channel. The RTSP content control media description shall be carried by TCP.

The SDP parameters for the RTSP content control channel shall be set as follows:

- a 'm' line for an RTSP stream of format: `m=<media> <port> <transport> <fmt>`
  - The media field shall have a value of "application".
  - The port field shall be set to a value of 9, which is the discard port. See RFC 4145 [13] and RFC 4572 [14].
  - The transport field shall be set to TCP or TCP/TLS. The former is used when RTSP runs directly on top of TCP and the latter is used when RTSP runs on top of TLS, which in turn runs on top of TCP.
  - The <fmt> parameter shall be included and shall be set to *3gpp\_rtsp*.

NOTE: the *3gpp\_rtsp* application format should have a new MIME subtype registered in IANA.

- An "a=setup" attribute shall be present and set to "active" indicating that the UE will initiate an outgoing TCP connection to the PSS Adapter [7] and [13].
- An "a= connection" attribute shall be present and set as "new" " indicating that the UE will establish a new outgoing TCP connection towards the PSS Adapter [7] and [13].
- A "c" line shall include the network type with the value set to IN, the address type set to IP4 or IP6 and IP address of the flow of the related RTSP content control (ex. `c=IN IP4 <IP_ADDRESS>`).

Example of RTSP 'm' line offer from the UE:

```
m=application 9 TCP 3gpp_rtsp
c=IN IP4 192.0.2.2
a=setup:active
a=connection:new
```

For each media stream controlled by the RTSP content control channel, the SDP offer shall include a "receiver only" content delivery channel media description set as defined in 3GPP TS 26.234 [8], clause 5.3.3:

- the "m=" line indicates the type of the media, the transport protocol and the port of the related content delivery channel. It may also include a fmt parameter which shall indicate the format given by the SSF, a subset of them or the format offered by the UE if none is given by the SSF;



- the "c=" line shall include the network type with the value set to IN, the address type set to IP4 or IP6 and unicast address of the flow of the related content delivery channel;  
(ex. c=IN IP4 <IP\_ADDRESS>)
- optionally a "b=" line may contain the proposed bandwidth. If the user has fetched the bandwidth required for this particular content delivery channel during service selection procedure, the bandwidth attribute at media level shall be set to this value. Otherwise, this attribute shall be set to a pre-configured value;  
(ex. b=AS:15000)
- A "a=" line with a "recvonly".

The UE should receive a SIP 200 OK back containing the final SDP.

### 8.2.3.3 Procedures at the IM CN Subsystem

The IM CN Subsystem handles the SIP dialog as defined in 3GPP TS 23.228 [6].

### 8.2.3.4 Procedures at the SCF

Upon receipt of SIP INVITE request, the SCF shall examine the Request-URI and SDP parameters to determine that it is a PSS session initiation request for Live Streaming or Content-On-Demand. According to the user subscription information, the SCF shall check the service rights of the requested PSS service.

If the Request-URI contains a content identifier in the user part and a domain name in the domain part, the SCF determines that the PSS streaming session is initiated for On Demand content. In this case, the SCF shall select a suitable PSS adapter and forwards the SIP INVITE to the selected PSS adapter by changing the Request-URI accordingly. The SCF shall not change the user part of the To header in order to keep the content identifier in the INVITE request.

When receiving a 301 or 302 response from the PSS adapter, the SCF shall not forward this message to the UE. It may check if the PSS adapter indicated in the Contact header belong to allowed destination. If allowed, the SCF shall use one of the PSS adapter URI indicated in the Contact header of this response and use it as a destination for the redirected INVITE.

If the request-URI contains the PSI "Live Stream", the SCF determines that the PSS streaming session is initiated for Live content. In this case, the SCF shall select a suitable PSS adapter and forwards the SIP INVITE to the selected PSS adapter. The SCF shall include the list of authorized Live content channels for the user in the SIP INVITE transmitted to the PSS adapter by including the package identifiers containing to the list of authorized Live content channels for the session and optionally transmitting the list of authorized RTSP URIs.

Based on the Request-URI and SDP parameters, the SCF selects a suitable PSS Adapter and forwards the SIP INVITE to the selected PSS Adapter.

Once receiving a SIP 200 OK response from PSS Adapter, the SCF shall forward the response to UE.

### 8.2.3.5 Procedures at the PSS Adapter

The PSS Adapter shall be statefully aware of any sessions between the PSS Adapter and a UE, and the PSS Adapter and the PSS Server related to the same streaming session. This means that the RTSP session between the PSS Adapter and the PSS Server and the SIP & RTSP sessions between the PSS Adapter and the UE are associated at the PSS Adapter in order to keep session structure and alignment. This includes, but is not limited to, RTSP parameters such as sessionId, IP version, CSeq, etc.

The PSS Adapter shall support the following RTSP methods for PSS Server session establishment and teardown control:

- DESCRIBE (PSS Adapter to PSS Server).
- SETUP (PSS Adapter to PSS Server).
- TEARDOWN (PSS Adapter to PSS Server).

The PSS Adapter should support the "3gpp-pipelined" feature so as to be able to pipeline SETUP messages.

Upon receipt of a SIP INVITE message, the PSS Adapter performs the following actions:

- It shall resolve the RTSP URI based on the R-URI, the SDP parameters and the selected PSS Server.
- It may send a DESCRIBE message to the PSS Server to fetch the SDP file.
- It shall construct and send the RTSP SETUP message(s) to setup the relevant media streams.
- Return the final SDP to the UE in the SIP 200 OK.

The PSS Adapter shall construct the RTSP SETUP message according to the SIP Invite as follows:

- The Request-Line shall be present of format: Request-Line = Method SP Request-URI SP RTSP-Version CRLF:
  - Method field is set to SETUP;
  - RTSP-Version field to be set of RTSP/1.0.
- The CSeq header field is set to a value allocated by PSS Adapter according to RFC 2326 [25]
- The transport header field:
  - the protocol and profile sub-fields together are set to a value of the protocol sub-field of the corresponding "m=" line in the SDP offer,
  - the unicast | multicast parameter is set to unicast.
  - The destination parameter is set to a value of the "c=" line of the corresponding media delivery channel in the SDP offer,
  - The RTP port value of client\_port parameter is set to the value of the port sub-field of the corresponding "m=" line in the SDP offer, and the RTCP port value of client\_port parameter is set to a value of the RTP port value plus 1.

An example of the RTSP SETUP message is:

```
PSS Adapter->PSS Server: SETUP rtsp://media.example.com/movie001/audiotrack RTSP/1.0
      CSeq: 1
      Transport: RTP/AVP/UDP; unicast; destination=<IP ADDRESS>; client_port=3400-3401
```

The PSS Adapter may send multiple RTSP SETUP messages if multiple media delivery channels are carried within the SDP offer. In this case, the pipeline of multiple RTSP SETUP messages may be supported.

When receiving a RTSP 200 OK response from the PSS Server, the PSS Adapter parses the response, constructs a SIP 200 OK response with the final SDP, and sends the SIP 200 OK response to the SCF. The final SDP shall describe the RTSP session established by the PSS Adapter and the TCP connection to be established by the UE.

The PSS Adapter shall construct the SIP 200 OK message according to RTSP 200 OK as follows:

- an 'm' line for an RTSP stream of format: m=<media> <port> <transport> <fmt>
  - The media field shall have a value of "application".
  - The port field shall be set to the value allocated by PSS Adapter for the UE to establish RTSP session, such as 554.
  - The transport field shall be set to TCP or TCP/TLS. The former is used when RTSP runs directly on top of TCP and the latter is used when RTSP runs on top of TLS, which in turn runs on top of TCP.
- a "c" line shall include the network type with the value set to IN, the address type set to IP4 or IP6 and IP address of PSS Adapter for the flow of the related RTSP content control (e.g. c=IN IP4 <IP\_ADDRESS>).
- The "setup" attribute is set to 'passive' indicating that connection shall be initiated by the other endpoint (UE).
- An "a= connection" attribute shall be present and set as "new" indicating that the UE will establish a new outgoing TCP connection towards the PSS Adapter [7][13].
- An "a=control" attribute shall be present in the format of an absolute URI to be used for the UE in the subsequent RTSP requests.
- One or more a=fmtp lines representing RTSP specific attributes set as follows:
  - a "fmtp:3gpp\_rtsp h-version" attribute representing the RTSP version which the PSS Adapter complies with.
  - a "fmtp:3gpp\_rtsp h-session" attribute representing the session identifier for the RTSP session to be established with the UE.

The PSS Adapter may include "fmtp: 3gpp\_rtsp h-offset" attribute that indicates where the playback is to start from.

Example of RTSP "m" line answer from the PSS Adapter:

```
m=application 554 TCP 3gpp_rtsp
c=IN IP4 192.0.2.1
a=setup:passive
a=connection:new
a=control:rtsp://example.com/channel/content1.sdp
a=fmtp 3gpp_rtsp version=1.0
a=fmtp 3gpp_rtsp h-session=12345
a=fmtp 3gpp_rtsp h-offset=30
```

For each media stream controlled by the RTSP content control channel, the SDP answer shall include a content delivery channel media description set as follows:

- the "m=" line indicates the type of the media, the transport protocol and the port of the related content delivery channel.
  - The port value shall be set to the RTP port value retrieved from the server\_port parameter in the RTSP 200 OK message.
  - If an fmtp parameter is in the SDP offer it shall be completed with the supported format by the PSS Server;
- the "c=" line shall include the network type with the value set to IN, the address type set to IP4 or IP6 and the unicast address of the PSS Server for the flow related to the content delivery channel, (ex. c=IN IP4 <IP\_ADDRESS>);
- the "b=" line shall contain the proposed bandwidth. Since the PSS media stream is unidirectional the bandwidth shall be set to 0, except for the case that the transport is RTP and RTCP is allowed. (ex. b=AS:0);
- an "a=" line with a value of "sendonly". (ex. a=sendonly).

## 8.2.4 PSS Streaming Playback Control

### 8.2.4.1 General Description

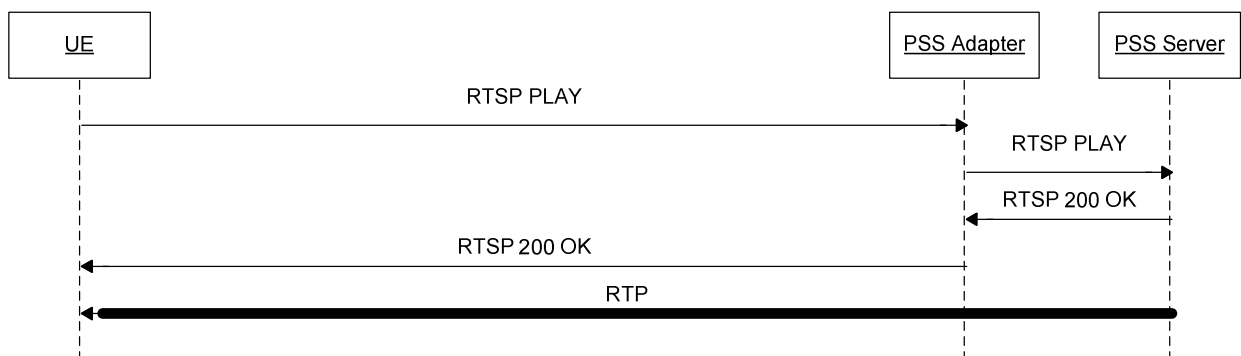

Figure 8: Initial Playback

### 8.2.4.1 Procedures at the UE

The UE shall support the following RTSP methods for RTSP playback control:

- PLAY (UE to PSS Adapter).
- PAUSE (UE to PSS Adapter).
- GET\_PARAMETER (UE to PSS Adapter).
- SET\_PARAMETER (UE to PSS Adapter).
- OPTIONS (UE to PSS Adapter).

When receiving any SIP response, the UE shall examine the media parameters in the received SDP: the UE shall immediately setup the TCP connection carrying RTSP. The UE shall fetch the RTSP session ID from the SDP answer contained in the SIP response. This RTSP session ID shall be used for RTSP media control messages.

After SIP session establishment, the UE can exchange RTSP messages to start to receive media streams. The UE shall send an RTSP PLAY message to the PSS adapter according to 3GPP TS 26.234 [8].

- The RTSP URL shall be set to the value retrieved from the SDP "a=control" attribute in the case of an absolute URI. If the value of "a=control" is a relative URI that is in the form of a media path, then the RTSP absolute URL is constructed by the UE using the SDP IP address (from c-line) and port (from m-line) as the base followed by "a=control" value for the media path.
- The RTSP session ID in the h-session received in the SDP shall be used in RTSP media control messages.
- The version attribute shall be present in the SDP and its value shall be 1.0 in this version of the specification.
- If the h-offset attribute is present in the SDP, the Range parameter in the first RTSP PLAY message may be set to its value. E.g. Range: npt=<OFFSET>- (with OFFSET being the value of the h-offset attribute).

#### 8.2.4.2 Procedures at the PSS Adapter

If the PSS Adapter supports the proxying of RTSP towards the PSS Server then the following methods shall be supported:

- PLAY;
- PAUSE;
- GET\_PARAMETER;
- SET\_PARAMETER;
- OPTIONS.

Upon receipt of a RTSP message from an UE, the PSS Adapter shall match the RTSP session with the RTSP sessions once established with PSS Server according to the Session ID carried in the received RTSP message. If there is a session match, PSS Adapter shall send the RTSP message to PSS Server on the matched RTSP session. If no session matches, PSS Adapter shall response with a RTSP error code 454 (Session Not Found).

When receiving a RTSP response message from a PSS Server, the PSS Adapter shall match the RTSP session with the RTSP sessions once established with UEs according to the Session ID carried in the received RTSP response message, and send the RTSP response message to UE on the matched RTSP session.

#### 8.2.4.3 Procedures at the PSS Server

The procedures at the PSS Server shall conform to those defined in 3GPP TS 26.234 [8].

### 8.2.5 PSS content switching

#### 8.2.5.1 PSS Streaming session modification

##### 8.2.5.1.1 General description

NOTE 1: The specification assumes the UE will trigger a Re-INVITE procedure to change the QoS to fit the new channel requirements. It will be considered whether the network can trigger the QoS change without the UE taking management.

This procedure presents the generic PSS streaming session modification procedure. It can be referred in some cases for PSS Content Switching, when there is a change of media components and/or bandwidth.

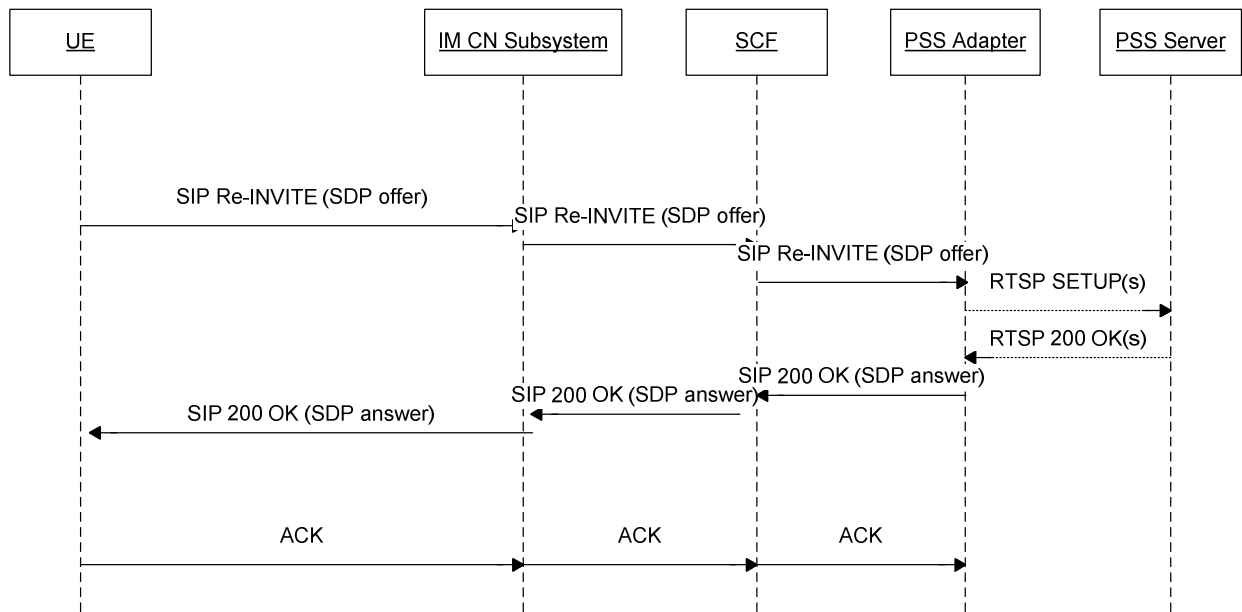

**Figure 9: UE-initiated PSS session modification**

NOTE 2: Like in other call-flows of the specification, the figure does not show that messages exchanged between the PSS adapter and the SCF are routed through the IM CN subsystem.

- 1) The UE sends the Re-INVITE request containing the SDP offer to the IM CN Subsystem to establish the content delivery channel. The IM CN Subsystem may require the PCRF to reserve additional resources for RTP streams according to the SDP in the Re-INVITE. The IM CN subsystem may also issue the PCRF to release resources for RTP streams.
- 2) The IM CN Subsystem forwards the Re-INVITE request to the SCF.
- 3) The SCF sends the Re-INVITE to the PSS adapter via the IM CN Subsystem.
- 4) The PSS adapter sends the according number of RTSP SETUP to the PSS server, if additional media components are described in the SDP.
- 5) The PSS server responds with RTSP 200 OK to the PSS adapter (only, if the PSS adapter has send SETUP messages to the PSS Server).
- 6) The PSS adapter sends one SIP 200 OK to the SCF with the SDP answer containing the new media descriptions of RTP streams to be used.
- 7) The SCF sends the SIP 200 OK to the IM CN Subsystem. The IM CN subsystem interacts with the PCRF to commit the reservation, and then forwards the SIP 200 OK to the UE.
- 8) The UE sends the SIP ACK to the IM CN subsystem, which forwards to the SCF. The SCF forwards the SIP ACK to the PSS adapter.

#### 8.2.5.1.2 Procedures at the UE

To modify the session, the UE shall send a Re-INVITE or an UPDATE request as specified in TS 24.229 [7] for an originating UE.

The UE shall not modify RTSP channel m-line description in the SDP if the media delivery streams controlled by RTSP are not removed (port not set to 0 in the m lines) in the SDP.

Upon receipt of a Re-INVITE request or an UPDATE request, the UE shall modify the request as specified in TS 24.229 [7] if the request is acceptable to the UE.

#### 8.2.5.1.3 Procedures at the IM CN subsystem

The IM CN subsystem handles the SIP dialog as defined in 3GPP TS 23.228 [6].

#### 8.2.5.1.4 Procedures at the SCF

Upon receipt of a Re-INVITE request or an UPDATE request, the SCF shall follow the procedures defined in TS 24.229 [7] concerning the AS acting as a terminating UA or a B2BUA.

When receiving an SDP offer, the SCF may modify the SDP answer in accordance to the user subscription. If the SCF finds a media line not compatible with the user's subscription, it shall set the port of this media line to 0. If none of the media lines are acceptable, it shall reply with a 403 error response.

Then the SCF forwards the Re-INVITE message to the PSS adapter.

#### 8.2.5.1.5 Procedures at the PSS adapter

Upon receipt of a Re-INVITE request or an UPDATE request, the PSS adapter shall modify the session as specified in TS 24.229 [7] if the request is acceptable to the PSS adapter in accordance with the user subscription.

The PSS adapter sets up new media components, if the SDP file contains additional components.

#### 8.2.5.1.6 Procedures at the PSS server

Upon receipt of an RTSP setup, the PSS server executes the requested method and responds with an RTSP status code to the PSS adapter.

### 8.2.5.2 PSS Content switching with available SDP, no change of media component and bandwidth

#### 8.2.5.2.1 General description

The UE has retrieved the SDP prior to the content switching. The procedure is as described as in 3GPP TS 26.234 [8], with the server role being played by the PSS adapter.

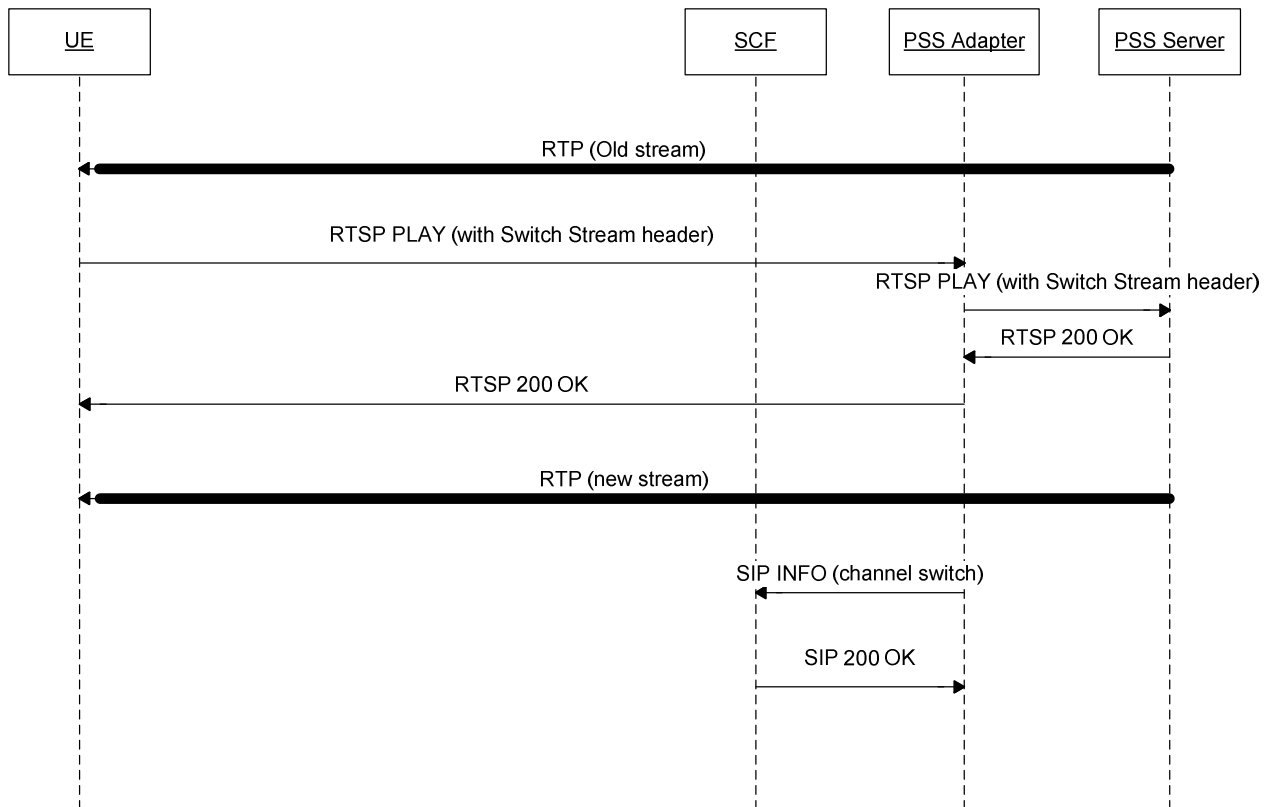

**Figure 10: IMS PSS Content switching**

NOTE: This sequence is simplified and does not e.g. show session progress messages and the ACK message from in response to the reception of 200 OK.

- 1) The UE sends a PLAY request with the aggregated control URI of the new content to the PSS adapter. The PSS client adds the media control URIs of the new streams in the "Switch-Stream" header field to the RTSP PLAY method request as defined 3GPP TS 26.234 [8] clause 5.5.4.3.
- 2) The PSS Adapter sends the RTSP PLAY message to the PSS Server.
- 3) The PSS Server responses a RTSP 200 OK message to the PSS Adapter.
- 4) The PSS Adapter sends the RTSP 200 OK message to UE.
- 5) The PSS server delivers the switched content streams to the UE.
- 6) The PSS Adapter should send a SIP INFO message to the SCF with content switching information. The content switching information may include the URIs of media streams before and after switching, and the mapping information of the URIs before and after switching.

The SIP INFO message shall contain an XML file with the content switching information.

- ImsPssMbmsCommand shall be set to "PssSwitch".
- ContentID is set to the RTSP URI of the new content.
- DateTime is set to the current date and time.

The Content-Type header shall be set to "application/3gpp-ims-pss-mbms-command+xml". The body content of the message is described in annex D and annex E.

The SCF may utilize the content switching information for statistic, charging etc. purpose, and may initiate a SIP Re-INVITE request to the UE to adjust the QoS reservation if the transport resources changed before and after switching.

#### 8.2.5.2.2 Procedures at the UE

To switch content of the PSS streaming session the UE shall send an RTSP PLAY request with the new content URI as defined in TS 26.234 [8] clause 5.5.4.

#### 8.2.5.2.3 Procedures at the IM CN Subsystem

The IM CN subsystem handles the SIP dialog as defined in 3GPP TS 23.228 [6].

#### 8.2.5.2.4 Procedures at the SCF

Upon receipt of a SIP INFO message the SCF shall send a SIP 200 OK to the PSS adapter.

The SCF may also decide to change the timer value, e.g. if it is overloaded. In this case, it shall include an XML document in the SIP 200 OK as defined in Annex C indicating the value of this timer. If the boolean variable SendSwitchingInfo is set to False, the PSS Adapter shall not send further SIP INFO messages for the life of the session.

#### 8.2.5.2.5 Procedures at the PSS Adapter

Upon identification of a successful content switch, the PSS Adapter starts the content switching timer for a particular session. If another content switch occurs during the life of the timer, the timer is restarted. If the session is terminated during the life of the timer, the timer is stopped. After timer expiration, the PSS Adapter should send a SIP INFO message to the SCF with content switching information as defined in Annex E. The content switching information may include the URIs of media streams after switching, and the mapping information of the URIs after switching.

#### 8.2.5.2.6 Procedures at the PSS Server

The PSS Server reacts as defined in 3GPP TS 26.234 [8] clause 5.5.4.

### 8.2.5.3 PSS Content switching with available SDP, change of media components or QoS

#### 8.2.5.3.1 General Description

Fast Content Switching as defined in 26.234 [8] Clause 5.5.4 allows also changing content when the new content channel requires a different number of media components as the old content channel, or when the bandwidth needs to be modified.

For instance, the old content stream consists out of an audio and a video stream and the new content channel offers an audio, video and 3GPP Timed Text media component. Addition a media component to an ongoing stream is defined in 26.234 [8] clause 5.5.4.6 and removing a media component in 26.234 [8] clause 5.5.4.7.



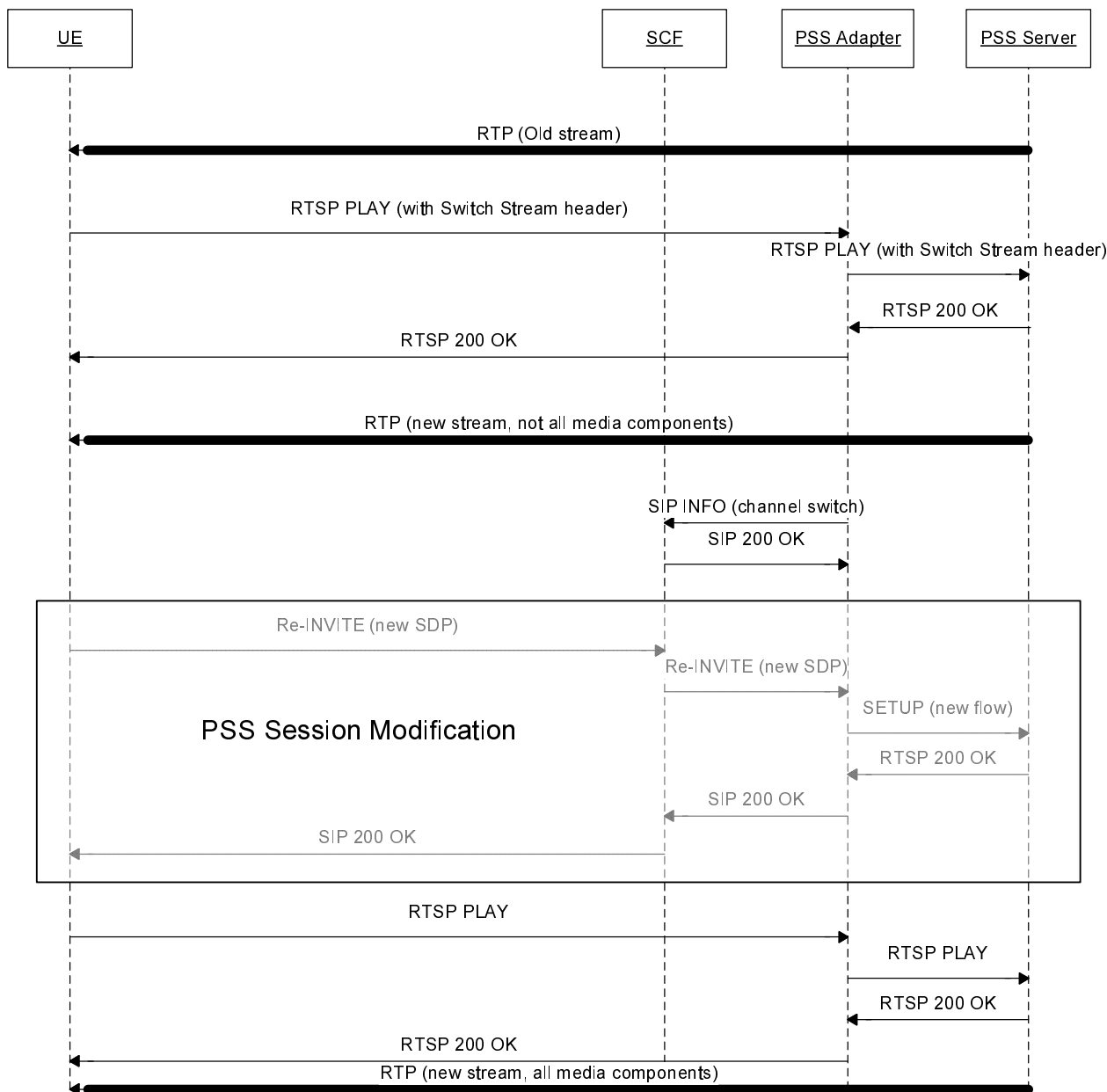

**Figure 11: IMS PSS Content switching**

NOTE 1: This sequence is simplified and does not e.g. show session progress messages and the ACK message from in response to the reception of 200 OK.

NOTE 2: The number of required RTSP SETUP interactions between the PSS Adapter and the PSS Server depend on the number of new media components in the SDP.

The UE determines that the new SDP file contains a different number of media components as the old SDP. The UE updates the streaming session by sending a Re-INVITE with the new SDP file, as described in clause 8.2.4.2 . As soon as the UE receives the 200 OK for the Re-INVITE, the UE initiates a PLAY to get the new synchronization information.

**8.2.5.3.2 Procedures at the UE**

The UE shall send an RTSP PLAY request with the new content URI as defined in TS 26.234 [8] clause 5.5.4. The UE changes the number of media components by sending a Re-INVITE message with the new SDP offer. After receiving the 200 OK for the Re-INVITE the UE initiates a PLAY to get the new synchronization information.

#### 8.2.5.3.3 Procedures at the IM CN Subsystem

The IM CN subsystem handles the SIP dialog as defined in 3GPP TS 23.228 [6].

#### 8.2.5.3.4 Procedures at the SCF

Upon receipt of a SIP INFO message the SCF shall send a SIP 200 OK to the PSS adapter.

The SCF may also decide to change the timer value, e.g. if it is overloaded. In this case, it shall include an XML document in the SIP 200 OK as defined in Annex C, indicating the value of this timer. If the boolean variable SendSwitchingInfo is set to False, the PSS Adapter shall not send further SIP INFO messages for the life of the session.

#### 8.2.5.3.5 Procedures at the PSS Adapter

Upon identification of a successful content switch, the PSS Adapter starts the content switching timer for a particular session. If another content switch occurs during the life of the timer, the timer is restarted. If the session is terminated during the life of the timer, the timer is stopped. After timer expiration, the PSS Adapter should send a SIP INFO message to the SCF with content switching information as defined in Annex E. The content switching information may include the URIs of media streams after switching, and the mapping information of the URIs after switching.

When receiving the SIP Re-INVITE message from the SCF, if a new media component needs to be added, the PSS adapter shall send the RTSP SETUP to the PSS server, indicating the new media component that needs to be added.

#### 8.2.5.3.6 Procedures at the PSS Server

The PSS Server behaves as defined in 3GPP TS 26.234 [8] clause 5.5.4

### 8.2.5.4 PSS Content switching with unavailable SDP, no change of media component and/or bandwidth

#### 8.2.5.4.1 General description

In this case, the UE does not have the SDP for the streams it intends to switch to. The new content has same media and bandwidth characteristics.

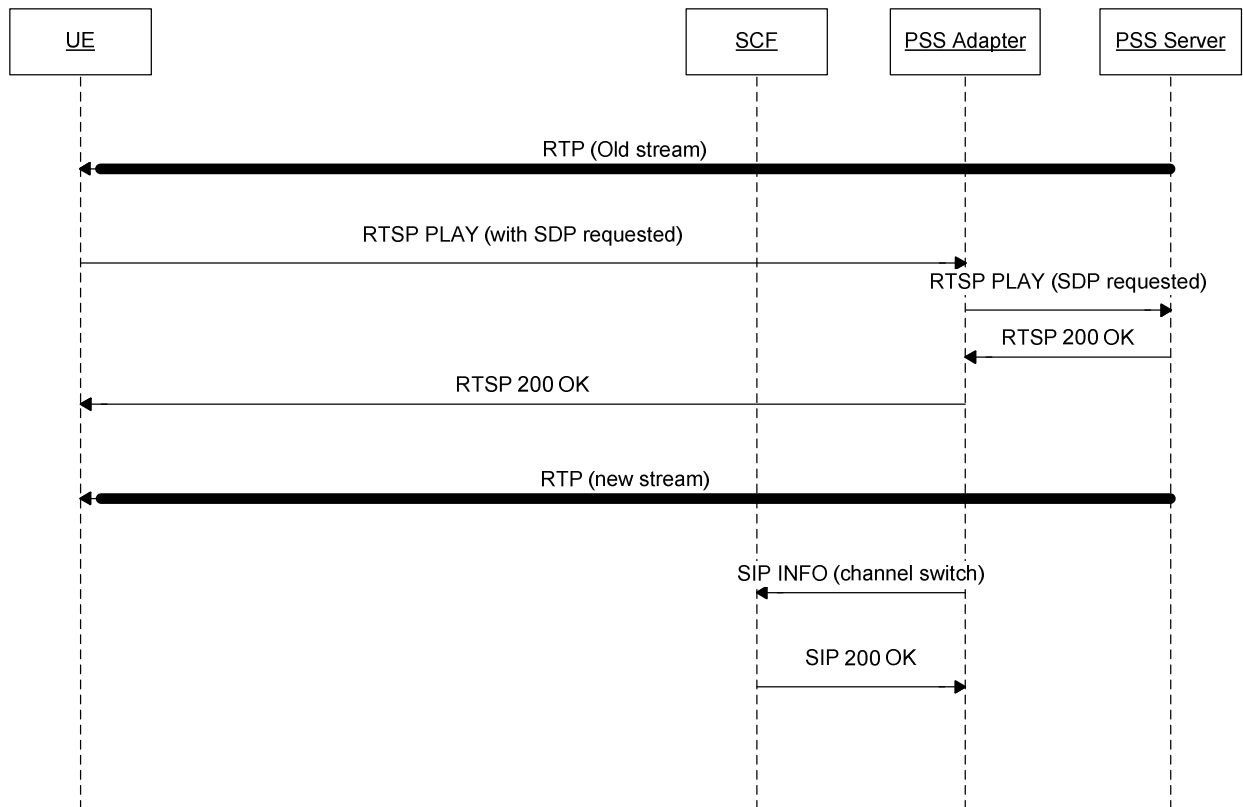

**Figure 12: IMS PSS Content switching without available SDP, no change of media component and/or bandwidth**

NOTE: This sequence is simplified and does not e.g. show session progress messages and the ACK message from in response to the reception of 200 OK.

The UE sends a PLAY request to the PSS adapter indicating that it needs the SDP for the new streams. The PSS Adapter sends the RTSP PLAY message to the PSS Server.

The PSS Server responds a RTSP 200 OK message to the PSS Adapter, PSS Adapter sends the RTSP 200 OK message to UE containing the SDP for the new streams.

The PSS server starts streaming the switched content streams to the UE.

The PSS Adapter should send a SIP INFO message to the SCF with content switching information according to clause 8.2.4.2.1.

#### 8.2.5.4.2 Procedures at the UE

To switch content of the PSS streaming session the UE shall send an RTSP PLAY to request the new SDP as defined in TS 26.234 [8].

#### 8.2.5.4.3 Procedures at the IM CN Subsystem

The IM CN subsystem handles the SIP dialog as defined in 3GPP TS 23.228 [6].

#### 8.2.5.4.4 Procedures at the SCF

Upon receipt of a SIP INFO message the SCF shall send a SIP 200 OK to the PSS adapter.

The SCF may also decide to change the timer value, e.g. if it is overloaded. In this case, it shall include an XML document in the SIP 200 OK as defined in Annex C indicating the value of this timer. If the boolean variable SendSwitchingInfo is set to False, the PSS Adapter shall not send further SIP INFO messages for the life of the session.

#### 8.2.5.4.5 Procedures at the PSS Adapter

Upon identification of a successful content switch, the PSS Adapter starts the content switching timer for a particular session. If another content switch occurs during the life of the timer, the timer is restarted. If the session is terminated during the life of the timer, the timer is stopped. After timer expiration, the PSS Adapter should send a SIP INFO message to the SCF with content switching information as defined in Annex E. The content switching information may include the URIs of media streams after switching, and the mapping information of the URIs after switching.

The PSS Adapter sends the RTSP 200 OK message to UE containing the SDP for the new stream.

#### 8.2.5.4.6 Procedures at the PSS Server

The PSS Server behaves as defined in 3GPP TS 26.234 [8] clause 5.5.4.

### 8.2.5.5 PSS Content switching with unavailable SDP, change of media component and/or bandwidth

#### 8.2.5.5.1 General description

In this case, the UE does not have the SDP for the streams it intends to switch to. And the new content has different media and/or bandwidth characteristics.

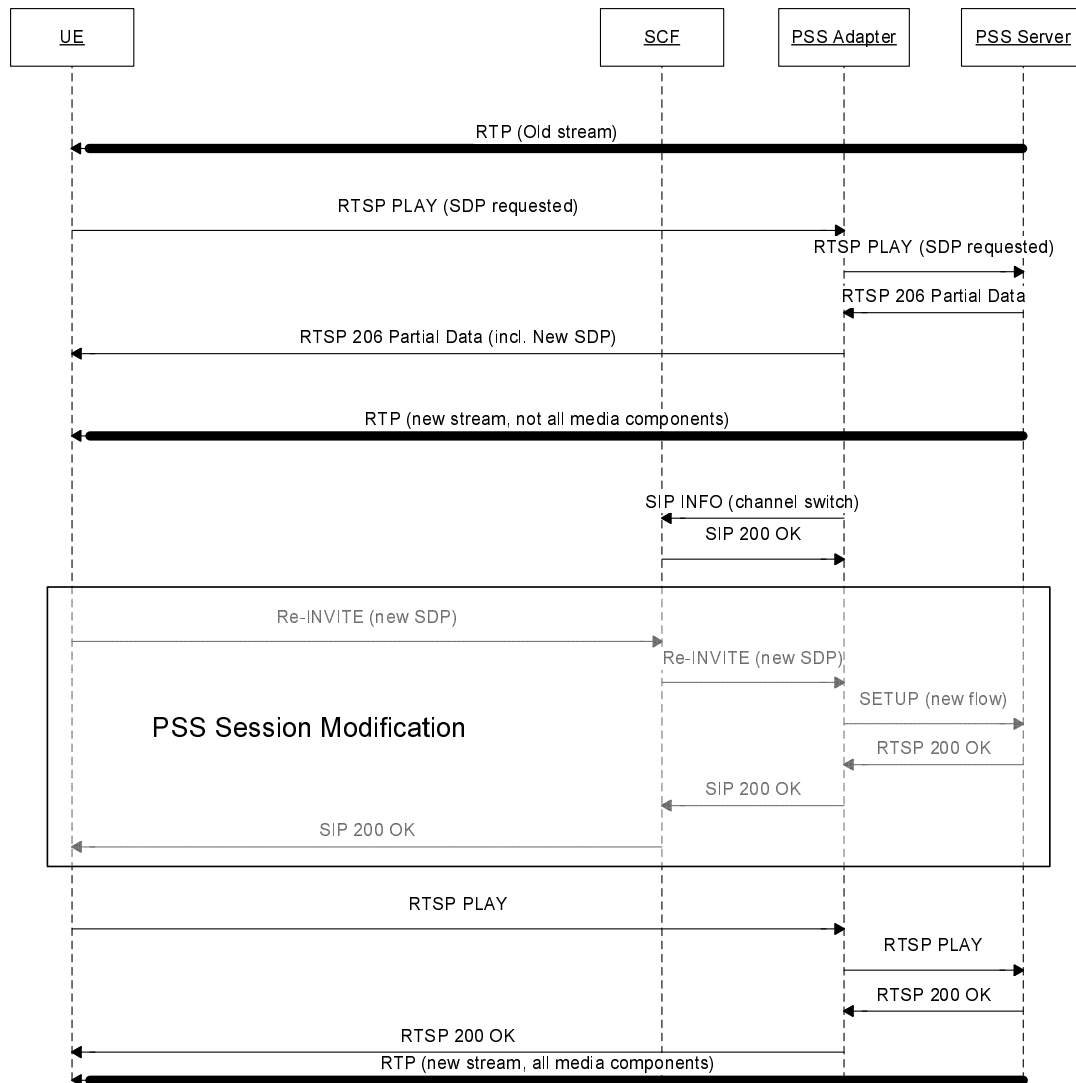

**Figure 13: IMS PSS Content switching without available SDP, change of media component and/or bandwidth**

The UE sends a PLAY request to the PSS adapter indicating that it needs the SDP for the new streams. The PSS Adapter sends the RTSP PLAY message to the PSS Server.. If the UE receives a "206 Partial Data" success status code, then the UE changes the number of media components and/or bandwidth by sending a RE-INVITE message with the new SDP file, as described in clause 8.2.4.1.

**8.2.5.5.2 Procedures at the UE**

If the UE receives a "206 Partial Data" success status code, then the UE changes the number of media components by sending a re-INVITE message with the new SDP file.

**8.2.5.5.3 Procedures at the IM CN Subsystem**

The IM CN subsystem handles the SIP dialog as defined in 3GPP TS 23.228 [6].

**8.2.5.5.4 Procedures at the SCF**

Upon receipt of a SIP INFO message the SCF shall send a SIP 200 OK to the PSS adapter.

The SCF may also decide to change the timer value, e.g. if it is overloaded. In this case, it shall include an XML document in the SIP 200 OK as defined in Annex C indicating the value of this timer. If the boolean variable SendSwitchingInfo is set to False, the PSS Adapter shall not send further SIP INFO messages for the life of the session.

8.2.5.5.5 Procedures at the PSS Adapter

Upon identification of a successful content switch, the PSS Adapter starts the content switching timer for a particular session. If another content switch occurs during the life of the timer, the timer is restarted. If the session is terminated during the life of the timer, the timer is stopped. After timer expiration, the PSS Adapter should send a SIP INFO message to the SCF with content switching information as defined in Annex E. The content switching information may include the URIs of media steams after switching, and the mapping information of the URIs after switching.

When receiving the SIP RE-INVITE message from the SCF, if a new media component needs to be added, the PSS adapter shall send the RTSP SET-UP to the PSS server, indicating the new media component that needs to be added.

8.2.5.5.6 Procedures at the PSS Server

The PSS Server reacts as defined in 3GPP TS 26.234 [8] clause 5.5.4.

8.2.6 PSS Streaming Session Teardown

8.2.6.1 General Description

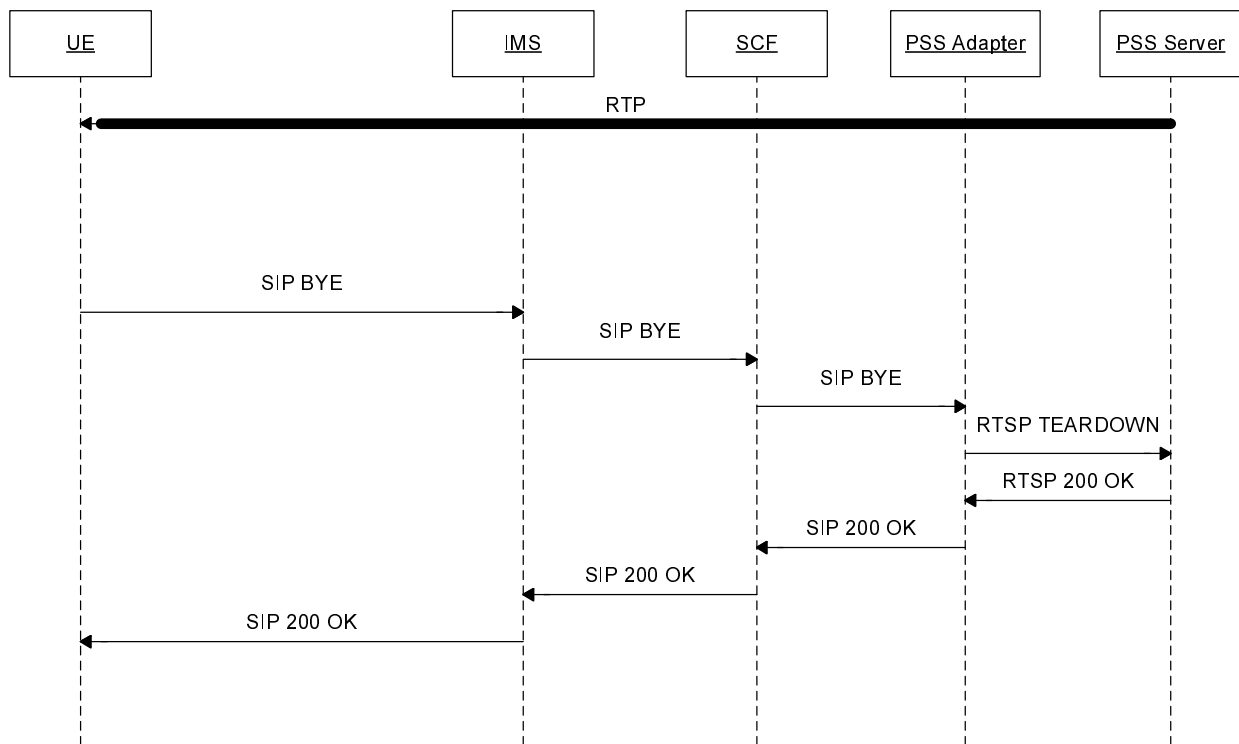

Figure 14: IMS PSS Session termination

NOTE: This sequence is simplified and does not e.g. show session progress messages and the ACK message from the UE in response to the reception of 200 OK

Assuming the streaming session is established, the session can be terminated by the UE or the SCF. Here the case of UE termination is described. The following steps are carried out:

- 1) Note that the PSS Adapter should maintain the RTSP session to the PSS Server until after step 5.
- 2) The UE sends a SIP BYE message.
- 3) The IMS CN subsystem forwards the SIP BYE message to the SCF.

- 4) The SCF sends the SIP BYE message to the PSS adapter.
- 5) The PSS adapter sends a RTSP TEARDOWN to the PSS server.
- 6) In case the PSS Server is transmitting RTP data it stops sending RTP data for this session. The PSS server sends a RTSP 200 OK to the PSS adapter.
- 7) The PSS adapter sends a SIP 200 OK to the UE via SCF and IMS CN subsystem.

### 8.2.6.2 Procedures at the UE

To teardown the PSS streaming session the UE shall close the TCP connection for RTSP between UE and PSS Adapter, if existing. Further, the UE shall send a SIP BYE to the SCF.

### 8.2.6.3 Procedures at the IM CN Subsystem

The IM CN subsystem handles the SIP dialog as defined in 3GPP TS 23.228 [6].

### 8.2.6.4 Procedures at the SCF

Upon receipt of a SIP BYE message the SCF shall forward it to the PSS adapter.

### 8.2.6.5 Procedures at the PSS Adapter

Upon receipt of a SIP BYE message from the SCF the PSS adapter shall send a RTSP TEARDOWN message to the PSS Server.

Upon receipt of a RTSP 200 OK message from the PSS server, the PSS adapter shall send a SIP 200 OK message to the SCF.

The PSS Adapter shall not close the RTSP session to the PSS Server on receipt of a TCP close, but waits until it has received the SIP BYE message in step 4.

### 8.2.6.6 Procedures at the PSS Server

Upon receipt of a RTSP TEARDOWN from the PSS adapter, the PSS server shall stop still on-going RTP transmissions and send a RTSP 200 OK message to the PSS adapter.

## 8.3 MBMS Streaming

### 8.3.1 MBMS Media codecs and formats

MBMS Media codecs and formats defined in 3GPP TS 26.346 [11] are applicable to the present document for IMS initiated and controlled MBMS User service.

### 8.3.2 Procedure for providing missing parameters before session initiation

#### 8.3.2.1 Procedures at the UE

If the UE does not have the all the information it needs to form an SDP offer, the UE shall send a SIP OPTIONS message.

The "Request-URI" is related to the MBMS service that the user wants to activate. The "Request-URI" shall be composed of a user and domain part as defined as follows:

- The user part contains the serviceId.
- The domain part is the Service Provider domain name, obtained from SSF.

The TO header shall contain the same URI as in the "Request-URI" parameter.

The FROM header shall indicate the public user identity of the user.

Upon reception of the 200 OK including service access information encapsulated in multipart/MIME, the UE shall initiate MBMS session as described in clause 8.3.3.

### 8.3.2.2 Procedures at the SCF

When receiving the SIP OPTIONS message, the SCF shall examine the serviceId present in the user-part of the TO header and lookup the requested User Service Description information.

The SCF shall answer with the user service description information of the content delivery channel (encapsulated in multipart/MIME) as requested by the serviceId.

## 8.3.3 MBMS Streaming Session initiation

### 8.3.3.1 General description

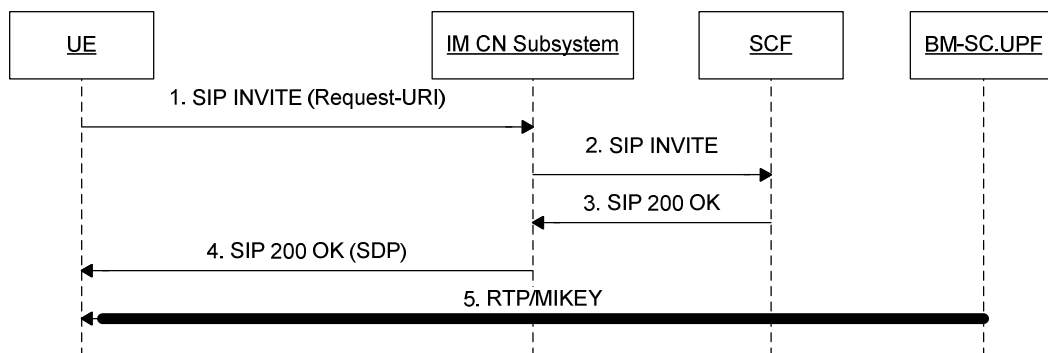

**Figure 15: MBMS Streaming Session Initiation**

It is assumed that the UE has already received the MBMS USD containing the SDP and associated fragments for the service from the SSF before initiating the MBMS session.

- Step 1, 2: UE initiates a SIP INVITE message to SCF, indicating which MBMS Streaming User Service the user has chosen.
- Step 3, 4: SCF responds UE with a SIP 200 OK message when the SIP INVITE is successfully handled. The SIP 200 OK contains an SDP files containing the Multicast address of the service. The UE then activates the MBMS bearers either using the MBMS Broadcast Service Activation procedure [4] or the MBMS Multicast Service Activation Procedure [4].
- Step 5: The UE can start receiving the MBMS Streaming session data when transmitted by the BM-SC.UPF.

The construction of the SDP is not affected by the use of MBMS stream bundling, see section 8.2.2 of [11], nor are any of the procedures.

### 8.3.3.2 Procedures at the UE

The UE shall support the procedures specified in TS 24 229 [7] for originating sessions.



The UE shall generate an initial INVITE request:

- The Request-URI in the INVITE request shall be the well known PSI (Public Service Identifier) of the MBMS Service.
- The To header shall contain the same URI as in the Request-URI.
- The From header shall indicate the public user identity of the user.

An SDP offer shall be included in the request. The SDP offer shall be done in accordance with the parameters received during UE service selection procedure and with media capabilities and required bandwidth available for the MBMS session. The SDP offer corresponds to the MBMS Streaming Session. See 3GPP TS 26.346 [11], clause 8.3.1. . The SDP offer at media level shall include the following elements:

- The m-line(s) shall be set to the media parameters retrieved via service selection procedures for the requested MBMS service.
- The c-line(s) shall be set according to the multicast address retrieved via service selection procedures for the requested MBMS service.
- An a=mbms\_service:MBMS\_ServiceId line to indicate the MBMS service which the UE intends to initiate first.

Once the UE receives the SIP response, the UE shall examine the media parameters in the received SDP, and initiate the MBMS channel according to the a=mbms\_service line. It can activate the corresponding MBMS User Service as described in the USDs. MBMS User Service reception initiation may correspond to the MBMS Broadcast Mode activations as described in 3GPP TS 23.246 [4], clause 8.12 or the MBMS Multicast Mode activation procedure as described in 3GPP TS 23.246 [4], clause 8.2.

### 8.3.3.3 Procedures at the IM CN Subsystem

Once the IMS CN receives the SIP response, PCC procedures are performed as described in clause 9.

### 8.3.3.4 Procedures at the SCF

The SCF shall support the procedures specified in TS 24.229 [7] applicable to an AS acting as a terminating UA.

Upon receipt of SIP INVITE request, the SCF shall perform service authorization procedures to check the service rights of requested MBMS service according to the user subscription information, See clause 5.4.

The SCF shall examine the SDP parameters in the SDP offer.

- It shall examine the a=mbms\_service parameter. This parameter contains the channel the UE intends to join. If the mbms\_service parameter does not point to a channel that the UE is allowed to join the SCF shall not accept the offer and shall answer with a 403 error code.
- It shall examine the c-line(s) to determine that it is a multicast session. It may also check that it corresponds to the mbms\_service parameter. If not, the SCF shall answer with an 403 error code.

If the SDP parameters are examined successfully, the SCF shall answer with a SIP 200 OK, indicating the SDP answer as follows:

- The c-lines and m-lines shall be identical to ones indicated in the SDP offer.
- It shall include an a=recvonly attribute.

### 8.3.3.5 Procedures at the BMSC.UPF

The MBMS session is already ongoing at the BMSC.UPF. No specific action is required.

## 8.3.4 MBMS content switching

### 8.3.4.1 General Description

It is assumed that MBMS streaming reception is already active and a stream is delivered to the UE via MBMS. In case of MBMS content switching, the UE tunes into a new content channel e.g. in case of MBMS multicast mode the UE leaves a multicast channel and joins another one.

The UE should send a SIP INFO Message to inform the SCF about which channel is being received unless the SCF prohibits it. A timer is started with a preconfigured value with default value of 10 seconds, when the channel switch is executed. After timer expiration the SIP INFO message is sent.

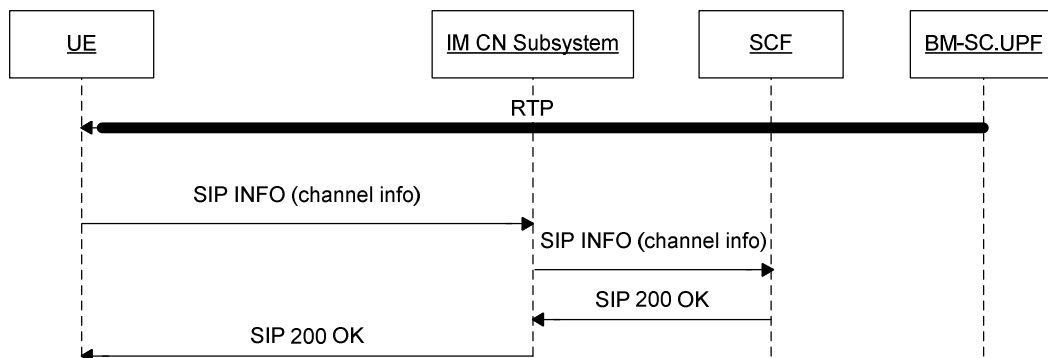

**Figure 16: MBMS content switching**

The UE sends content switching information to the SCF.

The content switching information may include the serviceId after switching. The SCF may utilize the content switching information for statistical or charging purposes etc.

### 8.3.4.2 Procedures at the UE

The UE performs MBMS content switching according to the deactivation/activation procedures defined in [4].

Upon identification of a successful content switch, the UE starts the content switching timer for a particular session. If another content switch occurs during the life of the timer, the timer is restarted. If the session is terminated during the life of the timer, the timer is stopped. After timer expiration, the UE should send a SIP INFO [Annex F] message to the SCF with content switching information.

The SIP INFO message shall be sent by the UE on the same dialogue as the MBMS session initiation and shall contain an XML file with the channel switch information.

- ImsPssMbmsCommand shall be set to "MbmsSwitch";
- ServiceId shall be set to the value of the new channel. If the OMA BCAST ESG [27] is used, this shall be set to Global Service ID, otherwise shall be set to the MBMS User Service Description serviceId.
- ProgrammeId may be present and if present shall be set to the identifier of the current programme of the new channel. If the OMA BCAST ESG [27] is used, this shall be set to service Name.
- DateTime shall be set to the date & time of the channel switch.

The Content-Type header shall be set to "application/3gpp-ims-pss-mbms-command+xml". The body content of the message is described in annex D and annex F.

### 8.3.4.2 Procedures at the IM CN Subsystem

The IM CN subsystem handles the SIP dialog as defined in 3GPP TS 23.228 [6].

### 8.3.4.3 Procedures at the SCF

Upon receipt of a SIP INFO message the SCF shall send a SIP 200 OK to the UE.

The SCF may also decide to change the timer value, e.g. if it is overloaded. In this case, it shall include an XML document in the SIP 200 OK as defined in Annex F indicating the value of this timer. If the boolean variable SendSwitchingInfo is set to False, the UE shall not send further SIP INFO messages for the life of the session.

### 8.3.4.4 Procedures at the BMSC.UPF

The BMSC.UPF transmits the RTP flows, and is not involved in the reporting of content switching information.

## 8.3.5 MBMS Streaming Session Teardown

### 8.3.5.1 General Description

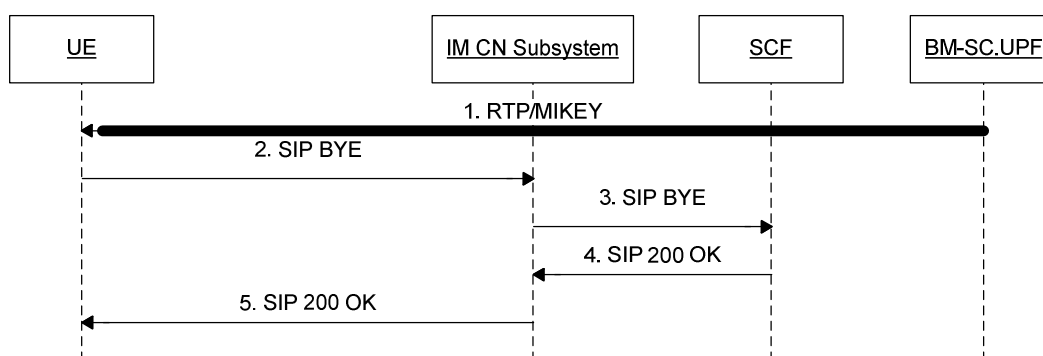

**Figure 17: MBMS Streaming Session Termination**

- Step 1: UE receives Streaming content from the BM-SC.UPF.
- Step 2, 3: UE initiates a SIP BYE message to SCF, indicating which MBMS Streaming session to close.
- Step 4, 5: SCF responds UE with a SIP 200 OK message when the SIP BYE is successfully handled and session terminated. At this stage, the UE can stop receiving the MBMS Streaming session.

The UE may deactivate the according MBMS Bearer Service during steps 2 to 5 or after step 5. The deactivation is either according to the MBMS Broadcast Service deactivation (3GPP TS 23.246 [4]) or the MBMS Multicast Mode deactivation procedure (3GPP TS 23.246 [4]).

### 8.3.5.2 Procedures at the UE

The UE shall send a SIP BYE to the SCF.

The UE may deactivate the according MBMS Bearer Service during steps 2 to 5 or after step 5 of clause 8.3.5.1. The deactivation is either according to the MBMS Broadcast Service deactivation (3GPP TS 23.246 [4]) or the MBMS Multicast Mode deactivation procedure (3GPP TS 23.246 [4]).

### 8.3.5.3 Procedures at the IM CN Subsystem

The IM CN subsystem handles the SIP dialog as defined in 3GPP TS 23.228 [6].

### 8.3.5.4 Procedures at the SCF

The SCF responds to the UE with a SIP 200 OK message after handling of the SIP BYE message.

### 8.3.5.5 Procedures at the BMSC.UPF

The BMSC.UPF is acting as described in 3GPP TS 23.246 [4].

## 8.4 Combined PSS and MBMS Streaming

### 8.4.1 Introduction

Combined PSS and MBMS streaming is important to ensure a consistent user experience. An UE may switch between one and the other depending on certain circumstances, e.g. changing between a PSS and MBMS coverage etc., or triggered by specific user action, e.g. trick play, etc.

It is assumed that the UE has an already established PSS or MBMS session and is capable of switching to the other delivery method.

Clause 8.4.2 gives the different cases and scenarios for switching between PSS and MBMS .

### 8.4.2 PSS - MBMS Switching

In the case of hybrid PSS-MBMS switching, it is distinguished between:

(a) switching from MBMS streaming to PSS streaming:

- Without channel change e.g. when a user is viewing an MBMS user service and moves out of MBMS coverage, or the user initiates trick play mode action, etc.
- With channel change e.g. changing to a channel only available on PSS.

(b) switching from PSS streaming to MBMS streaming:

- Without channel change e.g. the user returns back from trick play mode to a normal MBMS user service, etc.
- With channel change e.g. changing to a channel available on MBMS.

### 8.4.3 Switching from MBMS streaming to PSS streaming

According to clause 8.3.2 an MBMS streaming session was initiated and the UE is receiving the MBMS session from the BM-SC.UPF.

In order to switch from MBMS to unicast reception of a stream via PSS e.g. for allowing trick play mode, a SIP Re-INVITE is issued by the UE. A SDP offer shall be included according to clause 8.2.2.

After receiving the 200 OK, the UE leaves the multicast channel and starts playback.

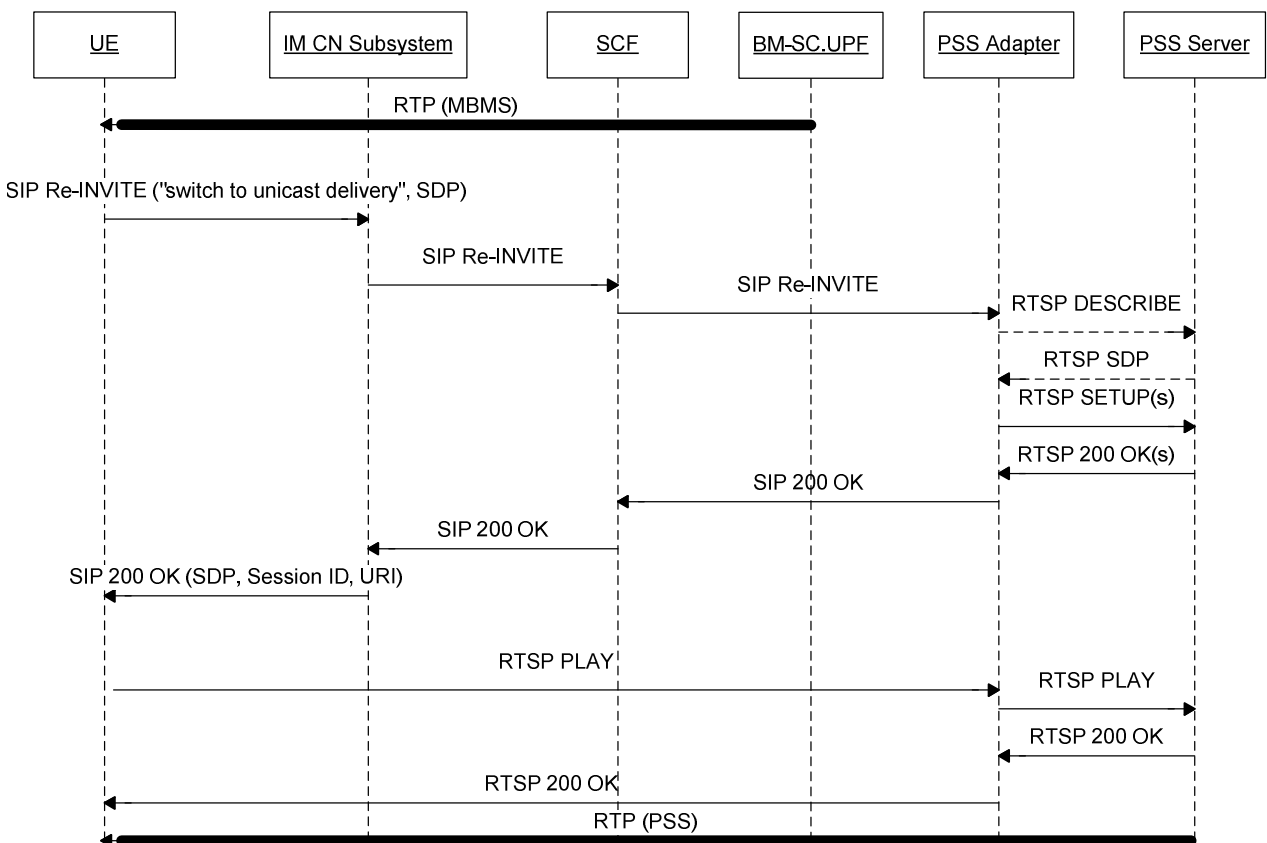

Figure 18: IMS Hybrid PSS-MBMS-to-PSS content switching

8.4.3.1 Combined Session establishment

8.4.3.1.1 Procedures at the UE

When the UE switches from an MBMS User Service to a PSS user service, the UE sends a session modification request, i.e. SIP re-INVITE, with a SDP Offer.

The SDP offer shall include previously negotiated media descriptions with the port set to zero and two or more additional media descriptions: one for media control channel (i.e. RTSP control channel) and one or more for media delivery channel (i.e. delivery channel for the unicast streams).

The RTSP control media descriptor shall follow TS 24.229 [7]. The SDP offer for media delivery shall be identical to the previous SDP offer done for broadcast in term of codecs and transport protocol.

The UE may record the media offset for the MBMS user service.

When receiving SIP 200 OK response, the UE shall setup a media control channel with the PSS Adapter, and setup a media delivery channel with PSS Server according to the SDP answer. The UE shall send RTSP PLAY message to start the delivery of the media streams.

8.4.3.1.2 Procedures at the IM CN Subsystem

The IM CN Subsystem handles the SIP dialog as defined in 3GPP TS 23.228 [6].

8.4.3.1.3 Procedures at the SCF

When receiving the SIP modification request, the SCF will determine if the programme currently broadcasted has MBMS to PSS switching support.

NOTE: The SCF may determine whether the SIP modification request is for MBMS to PSS switching according to the addition of the RTSP media control channel or unicast media delivery channel in the SDP offer.

If MBMS to PSS switching is not available for the UE, the session modification is rejected and the old MBMS session initiation (along with the previous reserved resources) is maintained.

If MBMS to PSS switching is available for the UE, the SCF forwards the session modification request with the SDP parameters for the content control channel of RTSP, and for the media delivery channel of unicast streams.

#### 8.4.3.1.4 Procedures at the PSS Adapter

When receiving a session modification request from SCF, as well as receiving RTSP 200 OK message from PSS Server, the PSS Adapter shall conform to clause 8.2.2.5.

Prior to replying, the PSS Adapter uses real time to calculate the media offset for the MBMS user service when replying with the offered media.

When receiving RTSP message from UE, the PSS Adapter shall conform to clause 8.2.3.2.

#### 8.4.3.1.5 Procedures at the PSS Server

The procedures at the PSS Server shall conform to those defined in 3GPP TS 26.234 [8].

#### 8.4.3.2 Combined session teardown

The combined session teardown shall conform to clause 8.2.5.

### 8.4.4 Switching from PSS streaming to MBMS streaming

According to clause 8.2.2 a PSS streaming session was initiated and the UE is receiving the PSS session from the PSS server.

In order to switch from PSS to MBMS reception of a stream, a SIP Re-INVITE is issued by the UE and sent to the SCF. An SDP offer shall be included according to clause 8.3.2. The SDP offer for media delivery shall be identical to the previous SDP offer done for PSS. Once the UE receives the SIP response, it can activate the corresponding MBMS User Service as described in the SDP. MBMS User Service reception initiation may correspond to the MBMS Broadcast Mode activation procedure as described in 3GPP TS 23.246 [4], clause 8.12 or the MBMS Multicast Mode activation procedure as described in 3GPP TS 23.246 [4], clause 8.2.

After switching to MBMS reception, the PSS session shall be terminated. Here, an RTSP TEARDOWN according to clause 8.2.3 shall be executed. The UE initiates the teardown of the streaming session as defined in clause 8.2.5.

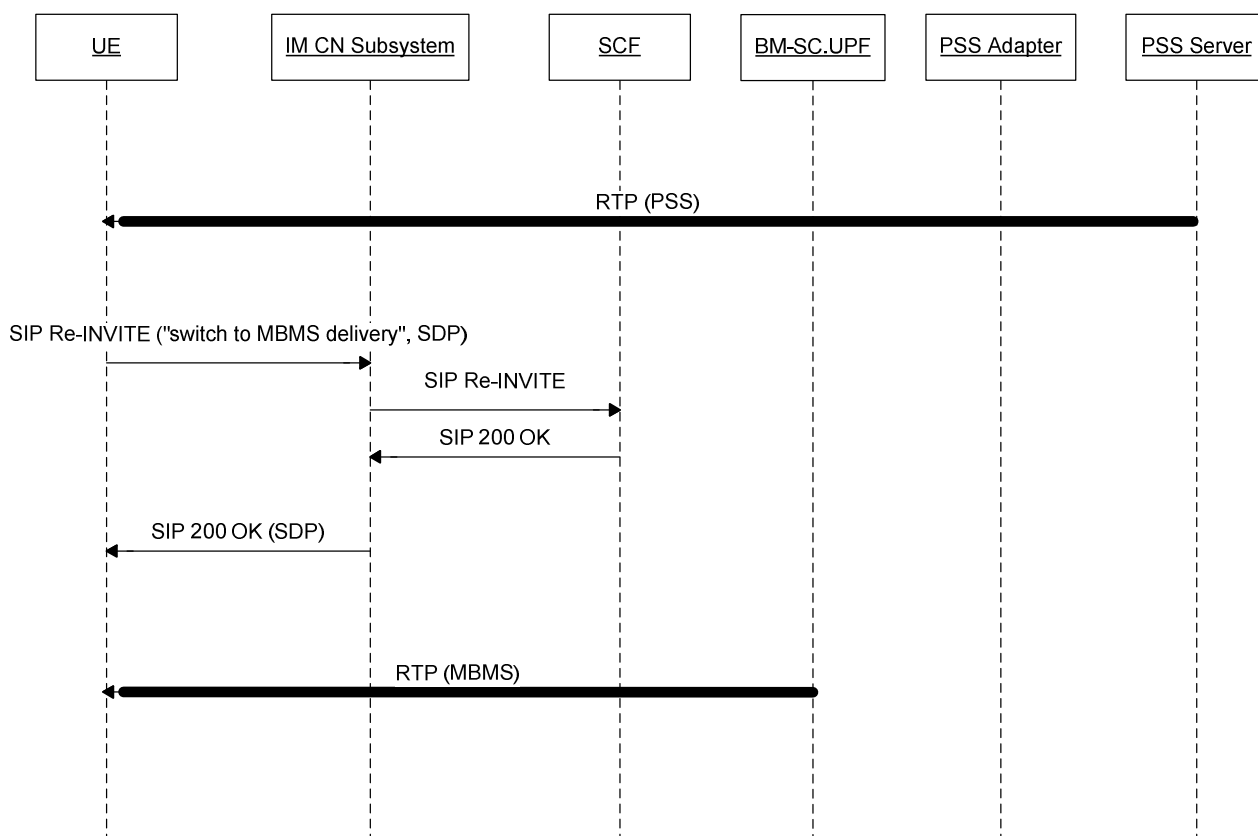

Figure 19: IMS PSS-to-MBMS content switching

## 9 Policy and charging control

### 9.1 General

For the purpose of the present specification, the policy and charging control is according to 3GPP TS 23.203 [12].

Service subscription control is performed by the SCF at registration and at PSS and MBMS session initiation.

QoS control is different for PSS and MBMS User Services. See clause 5.6.2.

### 9.2 QoS control

The P-CSCF is used as the Application Function in the PCC architecture. The PCRF decides how policy control of the QoS is performed for IMS initiated and controlled PSS and MBMS User Service.

In case of PSS, the PCRF shall use the SDP received from the P-CSCF during session establishment to calculate the proper QoS authorization and establish the relevant bearer. The way the QoS is enforced in this architecture is defined in 3GPP TS 23.203 [12].

In case of MBMS, the PCRF shall not initiate the establishment of a specific bearer. In this case the SDP in the SIP 200 OK Body only contains mandatory elements and the multicast address.

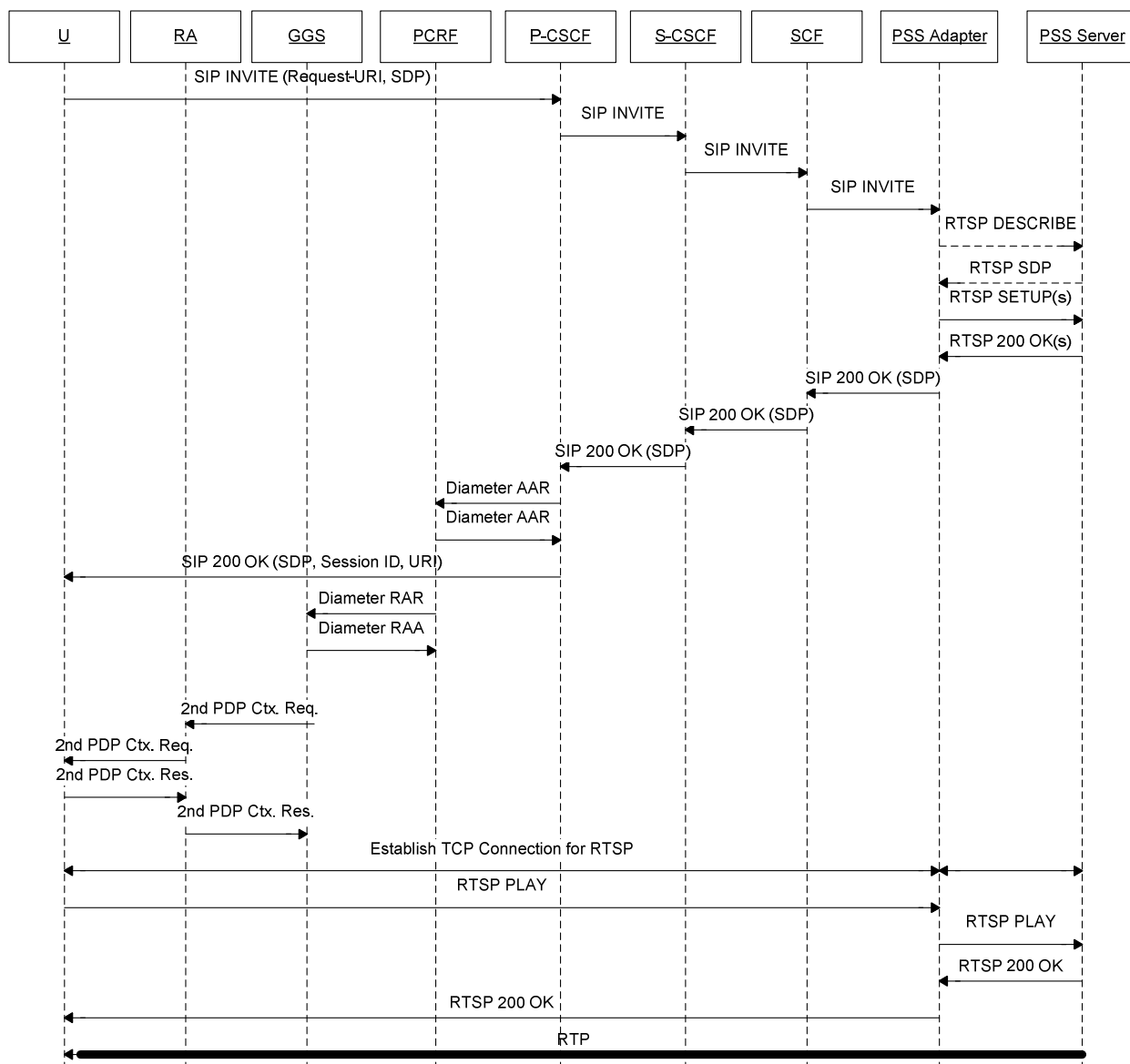

**Figure 20: PSS QoS Policy Control**

NOTE: The sequence shown is simplified and does not e.g. show session progress messages and the ACK message from the UE in response to the reception of 200 OK.

The PSS case of QoS control is shown on figure 20. The appropriate bearer is allocated by the PCRF. Network initiated bearer control is shown in the sequence, but a UE initiated is also possible.

## 10 Security Procedures

### 10.1 General

Different security procedures apply for IMS, MBMS and PSS.

IMS level authentication and access security is performed during IMS registration in accordance to [7].



PSS-Only: PSS defines an optional confidentiality protection of individual RTP payloads used in a streaming session. If PSS confidentiality protection as defined in 3GPP TS 26.234, Annex K, is used, then the terminal initiates the GAA/GBA Bootstrapping procedure TS 33.220 [26] after a successful IMS registration and Service discovery.

MBMS-only and combined PSS/MBMS service offerings: MBMS security is based on GAA/GBA [23]. The GAA/GBA Bootstrapping procedure is initiated by the UE after a successful IMS registration and Service discovery. It is necessary before any service description retrieval and session initiation.

GBA is used to generate a master key  $K_s$  from which NAF specific keys ( $K_{s\_NAF}$ ) can be derived when needed. It is also used to authenticate the user for signaling that is not performed via the IMS core network (e.g. HTTP based service description retrieval).

GBA is also used to generate and provision the  $K_{s\_NAF}$  - which is the Long Term Key that is used in content encryption/decryption procedures – and the B-TID – which is the corresponding bootstrapping transaction identifier.

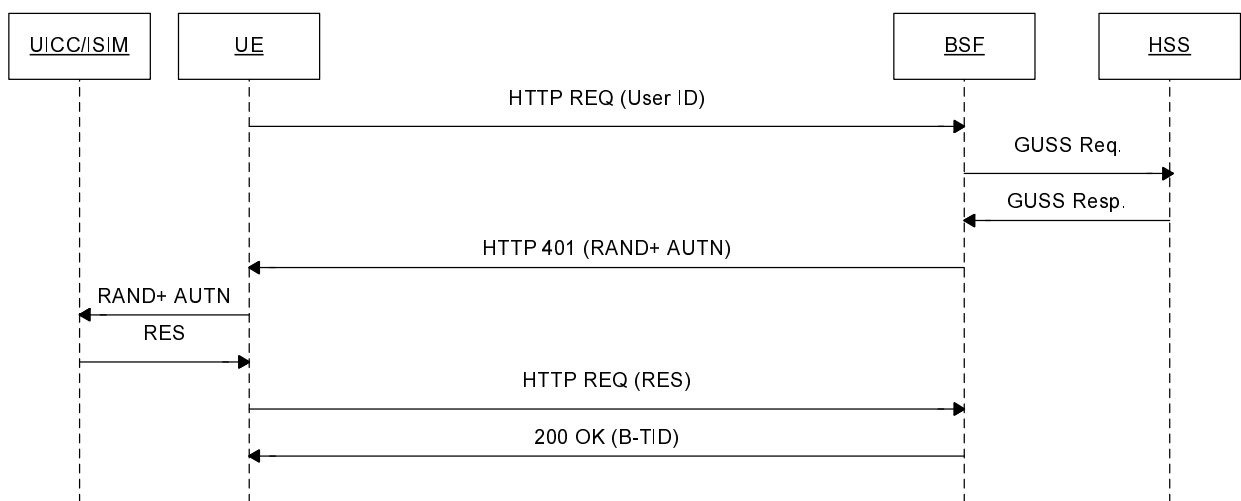

**Figure 21 GBA/GAA Bootstrapping procedure**

Figure 21 illustrates the GBA/GAA bootstrapping procedure. The following steps are performed. See [7] for details:

- The UE shall send a request to the BSF with its IMPI as User ID. The UE shall discover the address of the BSF as specified in [7].
- The BSF then acquires the User's GUSS (GBA User Security Settings) and one Authentication Vector from the HSS and forwards the RAND and AUTN to the UE in the HTTP 401 message.
- The UE checks AUTN to verify that the challenge is from an authorised network.
- The UE sends another HTTP request, containing the Digest AKA response (calculated using RES), to the BSF.
- The BSF authenticates the UE by verifying the Digest AKA response. The BSF shall send a 200 OK message, including a B-TID, to the UE to indicate the success of the authentication.

NOTE: It is FFS whether the ISIM or the USIM should be used for bootstrapping procedure. MBMS Rel-7 currently supports USIM and not ISIM. It is SA4 assumption that an ISIM is present in IMS based PSS&MBMS client UEs. Guidance from SA3 is required.

## 10.2 Secure Service Description Retrieval

The Service Description retrieval procedure allows the UE to acquire the necessary information to select and initiate PSS and/or MBMS sessions using IMS procedures. See clause 7 for more details on this procedure.

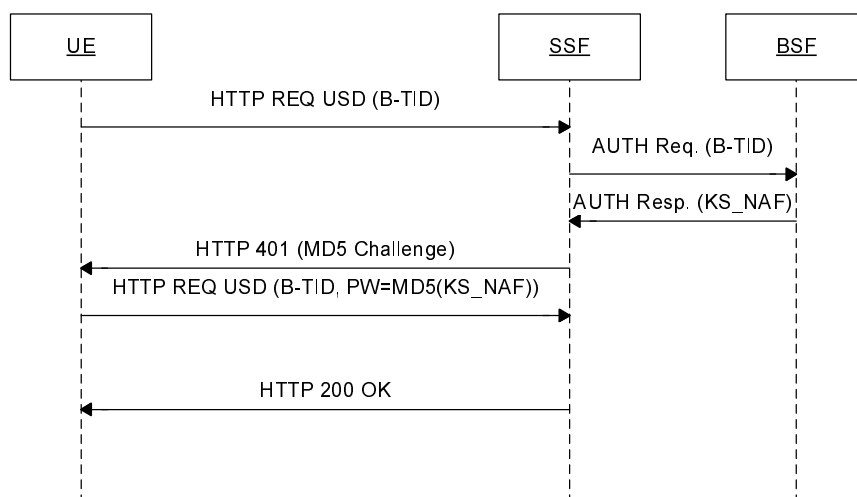

**Figure 22 Service Description retrieval with authentication**

Figure 22 describes the Service Description retrieval procedure with authentication.

The UE requesting a service description towards the SSF (acting as a NAF) shall include the B-TID corresponding to the Ks established during the bootstrapping procedure. When the SSF receives the service description request, it may trigger an authentication request towards the BSF to acquire the Ks\_NAF of the user. The SSF may trigger HTTP digest authentication procedure towards the UE in accordance with 3GPP TS 33.222 [20]. The UE responds to the challenge with B-TID as User ID and the MD5 encrypted Ks\_NAF as password. The SSF then checks the response to authenticate the user and send a 200 OK to indicate successful authentication and sends the service description with 200 OK.

The SSF may use the Ks\_NAF to encrypt the Service Description during retrieval.

### 10.3 PSS Authentication and Content encryption

Void (TBD).

### 10.4 MBMS Security procedures

Void (TBD).

---

## Annex A (normative): 3gpp\_rtsp application

The 3gpp\_rtsp application defines a set of RTSP parameters. An RTSP parameter is included in "a=fmtp" line of the SDP and is expressed in the form of parameter=value.

```
a=fmtp:3gpp_rtsp <parameter name>=<value>
```

The "version" parameter sets the "version-number" representing the version of RTSP that will be used in the RTSP media stream. The version number shall be "1.0" in this version of the specification. The RTSP version shall be included in all SDP offers and answers. The same version shall be used by all entities.

```
a=fmtp:3gpp_rtsp version=<version-number>
```

To exchange RTSP header fields within the SIP offer/answer, the RTSP media stream allows for attributes with the following format:

```
a=fmtp:3gpp_rtsp h-<header-name>=<header-value>,
```

where "header-name" is the name of the RTSP header field being described and "header-value" is the value of the RTSP header field. The value of the header-name is case insensitive. The value of the header-value is interpreted according to the rules of RTSP. The list of authorized headers in the SIP offer/answer is as follows:

- Session: this is the RTSP session id as established by the PSS adapter to be used for further RTSP transactions.
- Offset: this is a range value to be used in the first PLAY request by the UE.
- Supported" header filed with the following feature tags (see 3GPP TS 26.234 [8]):
  - "3gpp-switch" feature-tag, clause 5.5.4.2.
  - "3gpp-switch-req-sdp" feature-tag, clause 5.5.4.3.
  - "3gpp-switch-stream" feature-tag, clause 5.5.4.4.
- Require (see 3GPP TS 26.234 [8]).
- Pipelined-Requests (see 3GPP TS 26.234 [8]).
- 3GPP-Adaptation (see 3GPP TS 26.234 [8]).

UE, PSS Servers and PSS adapters shall support all these headers and feature tags.

## Annex B (informative): Examples

Void (TBD).

---

## Annex C (normative): XML Schema for timer modification

This XML Schema defines the timer modification signalled by the SCF within the body of SIP 200 OK response.

This XML may be included by the SCF:

- For PSS, in the SIP 200 OK response to the SIP INFO message sent after PSS Content Switching
- For MBMS, in the SIP 200 OK response to either the SIP INVITE of the MBMS Streaming session set-up, or the SIP INFO message sent by the UE after MBMS Content Switching.

```
<?xml version="1.0" encoding="UTF-8"?>
<xs:schema
targetNamespace="urn:3GPP:metadata:2008:IMS-PSS-MBMS:TimerModif"
xmlns:xs="http://www.w3.org/2001/XMLSchema"
elementFormDefault="qualified" attributeFormDefault="unqualified">

  <xs:annotation>
    <xs:documentation xml:lang="en">
Indicates modification of the timer value for content switching information reported to the SCF
</xs:documentation>
</xs:annotation>

  <xs:element name="Timer" type="xs:restriction"/>
    <xs:restriction base="xs:integer">
      <xs:minLength value="0"/>
      <xs:maxLength value="3600"/>
    </xs:restriction>

  <xs:simpleType name="SendSwitchingInfo">
<xs:restriction base="xs:boolean"/>
</xs:simpleType>

</xs:schema>
```

---

## Annex D (normative): XML Schema for PSS and MBMS commands

```
<?xml version="1.0" encoding="UTF-8"?>
<xs:schema xmlns:xs="http://www.w3.org/2001/XMLSchema"
xmlns:pss="urn:org:etsi:ngn:params:xml:ns:PssContentSwitchData"
xmlns:mbms="urn:org:etsi:ngn:params:xml:ns:MbmsContentSwitchData"
xmlns:local="urn:org:etsi:ngn:params:xml:ns:PssMbmscommand"
targetNamespace="urn:org:etsi:ngn:params:xml:ns:PssMbmscommand" elementFormDefault="qualified"
attributeFormDefault="unqualified">
  <xs:import namespace="urn:org:etsi:ngn:params:xml:ns:PssContentSwitchData"
schemaLocation="PssSwitchData.xsd"/>
  <xs:import namespace="urn:org:etsi:ngn:params:xml:ns:MbmsContentSwitchData"
schemaLocation="MbmsSwitchData.xsd"/>
  <xs:element name="ImsPssMbmsCommand">
    <xs:complexType>
      <xs:choice>
        <xs:element name="PssSwitch" type="local:tPssSwitch" minOccurs="0"
maxOccurs="unbounded"/>
        <xs:element name="MbmsSwitch" type="local:tMbmsSwitch" minOccurs="0"
maxOccurs="unbounded"/>
      </xs:choice>
    </xs:complexType>
  </xs:element>
  <xs:complexType name="tPssSwitch">
    <xs:choice>
      <xs:element ref="pss:PssSwitchData"/>
    </xs:choice>
  </xs:complexType>
  <xs:complexType name="tMbmsSwitch">
    <xs:choice>
      <xs:element ref="mbms:MbmsSwitchData"/>
    </xs:choice>
  </xs:complexType>
</xs:schema>
```

---

## Annex E (normative): XML Schemas for the PSS content switch data

This annex specifies XML schemas for PSS content switch data:

```
<?xml version="1.0" encoding="UTF-8"?>
<xs:schema xmlns:xs="http://www.w3.org/2001/XMLSchema"
xmlns="urn:org:etsi:ngn:params:xml:ns:PssContentSwitchData"
targetNamespace="urn:org:etsi:ngn:params:xml:ns:PssContentSwitchData" elementFormDefault="qualified"
attributeFormDefault="unqualified">
  <xs:element name="PssSwitchData">
    <xs:complexType>
      <xs:sequence>
        <xs:element name="ContentID" type="xs:string" minOccurs="0"/>
        <xs:element name="DateTime" type="xs:dateTime" minOccurs="0"/>
        <xs:element name="Extension" type="tExtension" minOccurs="0"/>
        <xs:any namespace="##other" processContents="lax" minOccurs="0" maxOccurs="unbounded"/>
      </xs:sequence>
    </xs:complexType>
  </xs:element>
  <xs:complexType name="tExtension">
    <xs:sequence>
      <xs:any processContents="lax" minOccurs="0" maxOccurs="unbounded"/>
    </xs:sequence>
  </xs:complexType>
</xs:schema>
```

---

## Annex F (normative): XML Schemas for the MBMS content switch data

This annex specifies XML schemas for MBMS content switch data:

```
<?xml version="1.0" encoding="UTF-8"?>
<xs:schema xmlns="urn:org:etsi:ngn:params:xml:ns:MbmsContentSwitchData"
xmlns:xs="http://www.w3.org/2001/XMLSchema"
targetNamespace="urn:org:etsi:ngn:params:xml:ns:MbmsContentSwitchData"
elementFormDefault="qualified" attributeFormDefault="unqualified">
  <xs:element name="MbmsSwitchData">
    <xs:complexType>
      <xs:sequence>
        <xs:element name="ServiceId" type="xs:string" minOccurs="0"/>
        <xs:element name="ProgrammeId" type="xs:string" minOccurs="0"/>
        <xs:element name="DateTime" type="xs:dateTime" minOccurs="0"/>
        <xs:element name="Extension" type="tExtension" minOccurs="0"/>
        <xs:any namespace="##other" processContents="lax" minOccurs="0" maxOccurs="unbounded"/>
      </xs:sequence>
    </xs:complexType>
  </xs:element>
  <xs:complexType name="tExtension">
    <xs:sequence>
      <xs:any processContents="lax" minOccurs="0" maxOccurs="unbounded"/>
    </xs:sequence>
  </xs:complexType>
</xs:schema>
```



## Annex G (normative): XML Schema for PSS and MBMS UE Device Capabilities

This XML Schema defines the UE device capabilities that are signalled by the UE within the body of the SIP SUBSCRIBE request when attaching to the service. Another document is also part of the body to describe PSS Capabilities as defined in TS 26.234.

```
<?xml version="1.0" encoding="UTF-8"?>
<xs:schema
targetNamespace="urn:3GPP:metadata:2008:IMS-PSS-MBMS:UECap"
xmlns:xs="http://www.w3.org/2001/XMLSchema"
elementFormDefault="qualified" attributeFormDefault="unqualified">

  <xs:annotation>
    <xs:documentation xml:lang="en">
      Defines the capabilities of the UE that is currently associated with the user
    </xs:documentation>
  </xs:annotation>

  <xs:element name="UEInformation" type="tUEProfile"/>
  <xs:complexType name="tUEProfile">
    <xs:sequence>
      <xs:element name="UserEquipmentModelName" type="xs:string"/>
      <xs:element name="UserEquipmentModelVersion" type="xs:string"/>
      <xs:element name="UserEquipmentID" type="tUEID"/>
      <xs:element name="UserEquipmentClass" type="tUserEquipmentClass"/>
      <xs:element name="UserEquipmentMBMSCapable" type="xs:boolean"/>
    </xs:sequence>
  </xs:complexType>

  <xs:simpleType name="tUEID" final="list restriction">
<xs:annotation>
  <xs:documentation>
    <label xml:lang="en">User Equipment ID</label>
    <definition xml:lang="en">Unique Identifier for the UE(eg;Could be MAC address of UE)
  </definition>
  </xs:documentation>
</xs:annotation>
  <xs:restriction base="xs:string">
    <xs:minLength value="0"/>
    <xs:maxLength value="16"/>
  </xs:restriction>
</xs:simpleType>

  <xs:simpleType name="tUserEquipmentClass" final="list restriction">
<xs:annotation>
  <xs:documentation>
    <label xml:lang="en">User Equipment class</label>
    <definition xml:lang="en">Specifies the type of UE</definition>
  </xs:documentation>
</xs:annotation>
  <xs:restriction base="xs:string">
    <xs:enumeration value="STB"> </xs:enumeration>
    <xs:enumeration value="PC"> </xs:enumeration>
    <xs:enumeration value="Handset"> </xs:enumeration>
  </xs:restriction>
</xs:simpleType>
</xs:schema>
```

## Annex H (normative): XML Schema for Service Attachment Information

This annex describes the XML schema for the service attachment information to be returned to UE by SDF.

```

<?xml version="1.0" encoding="UTF-8"?>
<xs:schema xmlns:xs="http://www.w3.org/2001/XMLSchema" elementFormDefault="qualified"
attributeFormDefault="unqualified">

  <xs:element name="SSF" type="tSSF">
    <xs:annotation>
      <xs:documentation>XML Body of the SDF SIP Notify Response</xs:documentation>
    </xs:annotation>
  </xs:element>

  <xs:complexType name="tSSF">
    <xs:sequence>
      <xs:element name="Description" type="tMultilingual" minOccurs="0"
maxOccurs="unbounded"/>
      <xs:element name="ServiceProvider" type="tSSFSERVICEProvider" minOccurs="0"/>
      <xs:element name="Pull" type="tSSFPull" minOccurs="0" maxOccurs="unbounded"/>
      <xs:element name="Push" type="tSSFPush" minOccurs="0" maxOccurs="unbounded"/>
      <xs:element name="Extension" type="tExtension" minOccurs="0"/>
      <xs:any namespace="##other" processContents="lax" minOccurs="0" maxOccurs="unbounded"/>
    </xs:sequence>
    <xs:attribute name="ID" type="tHexadecimal16bit" use="required"/>
    <xs:attribute name="Technology" type="xs:string" use="required"/>
    <xs:attribute name="Version" type="tVersion">
      <xs:annotation>
        <xs:documentation>The version number is incremented when one or more attributes of
the SSF element have changed, so that the receiver knows whether it should update its data or
not.</xs:documentation>
      </xs:annotation>
    </xs:attribute>
    <xs:anyAttribute namespace="##other" processContents="lax"/>
  </xs:complexType>

  <xs:simpleType name="tVersion">
    <xs:restriction base="xs:integer">
      <xs:minInclusive value="0"/>
      <xs:maxInclusive value="255"/>
    </xs:restriction>
  </xs:simpleType>

  <xs:complexType name="tSSFSERVICEProvider">
    <xs:sequence>
      <xs:element name="Name" type="tMultilingual" maxOccurs="unbounded"/>
      <xs:element name="Description" type="tMultilingual" minOccurs="0"
maxOccurs="unbounded"/>
      <xs:element name="Extension" type="tExtension" minOccurs="0"/>
    </xs:sequence>
    <xs:attribute name="DomainName" type="tDomain" use="required">
      <xs:annotation>
        <xs:documentation>It is recommended that the DomainName complies with the "preferred
name syntax" of RFC1034 clause 3.5</xs:documentation>
      </xs:annotation>
    </xs:attribute>
    <xs:attribute name="LogoURI" type="xs:anyURI" use="optional"/>
    <xs:anyAttribute namespace="##other" processContents="lax"/>
  </xs:complexType>

  <xs:simpleType name="tDomain">
    <xs:restriction base="xs:string">
      <xs:pattern value="((\.|\\n|\\r)*)?(\.(\.|\\n|\\r)*)+"/>
    </xs:restriction>
  </xs:simpleType>

  <xs:complexType name="tSSFPull">
    <xs:complexContent>
      <xs:extension base="tDataTypeList">
        <xs:attribute name="Location" type="xs:anyURI" use="required"/>
        <xs:anyAttribute namespace="##other" processContents="lax">
          <xs:annotation>
            <xs:documentation>Extension attribute to define further
data</xs:documentation>
          </xs:annotation>
        </xs:anyAttribute>
      </xs:extension>
    </xs:complexContent>
  </xs:complexType>

```

```

        </xs:annotation>
      </xs:anyAttribute>
    </xs:extension>
  </xs:complexContent>
</xs:complexType>

<xs:complexType name="tSSFPush">
  <xs:complexContent>
    <xs:extension base="tDataTypeList">
      <xs:attribute name="IpVersion" type="tVersion" use="optional"/>
      <xs:attribute name="MulticastAddress" type="xs:string" use="required"/>
      <xs:attribute name="MulticastPort" type="xs:unsignedShort" use="required"/>
      <xs:attribute name="SourceAddress" type="xs:string" use="optional"/>
      <xs:anyAttribute namespace="##other" processContents="lax">
        <xs:annotation>
          <xs:documentation> Extension attribute to define further data
        </xs:documentation>
      </xs:annotation>
    </xs:extension>
  </xs:complexContent>
</xs:complexType>

<xs:complexType name="tDataTypeList">
  <xs:sequence maxOccurs="unbounded">
    <xs:element name="DataType">
      <xs:complexType>
        <xs:sequence minOccurs="0" maxOccurs="unbounded">
          <xs:element name="Segment">
            <xs:annotation>
              <xs:documentation>Segments are used to logically separate Service
Selection information</xs:documentation>
            </xs:annotation>
            <xs:complexType>
              <xs:attribute name="ID" type="tHexadecimal16bit" use="required"/>
              <xs:attribute name="Version" type="tVersion" use="optional"/>
            </xs:complexType>
          </xs:element>
        </xs:sequence>
        <xs:attribute name="Type" type="tHexadecimal8bit" use="required">
          <xs:annotation>
            <xs:documentation> Specify the type of Service Selection Information
that is delivered by the SSF
          </xs:documentation>
          </xs:annotation>
        </xs:attribute>
      </xs:complexType>
    </xs:element>
  </xs:sequence>
</xs:complexType>

<xs:complexType name="tExtension">
  <xs:sequence>
    <xs:any processContents="lax" minOccurs="0" maxOccurs="unbounded"/>
  </xs:sequence>
</xs:complexType>

<xs:complexType name="tMultilingual">
  <xs:simpleContent>
    <xs:extension base="xs:string">
      <xs:attribute name="Language" type="tLanguage" use="required"/>
    </xs:extension>
  </xs:simpleContent>
</xs:complexType>

<xs:simpleType name="tLanguage">
  <xs:restriction base="xs:string">
    <xs:annotation>
      <xs:documentation>
        <definition xml:lang="en">ISO 639-2 Language code</definition>
      </xs:documentation>
    </xs:annotation>
    <xs:minLength value="3"/>
    <xs:maxLength value="3"/>
  </xs:restriction>
</xs:simpleType>

```

```
<xs:simpleType name="tHexadecimal8bit">
  <xs:restriction base="xs:string">
    <xs:pattern value="[0-9a-fA-F]{1,2}"/>
  </xs:restriction>
</xs:simpleType>

<xs:simpleType name="tHexadecimal16bit">
  <xs:restriction base="xs:string">
    <xs:pattern value="[0-9a-fA-F]{1,4}"/>
  </xs:restriction>
</xs:simpleType>

</xs:schema>
```

---

## Annex I (informative): Change history

Change history							
Date	TSG #	TSG Doc.	CR	Rev	Subject/Comment	Old	New
2008-12		GP-080675			Presented for approval at TSG SA#42	1.0.0	2.0.0
2008-12					Approved at TSG SA#42	2.0.0	8.0.0

---

# History

<b>Document history</b>		
V8.0.0	January 2009	Publication