

ETSI TS 126 267 V9.1.0 (2010-06)

Technical Specification

**Digital cellular telecommunications system (Phase 2+);
Universal Mobile Telecommunications System (UMTS);
eCall data transfer;
In-band modem solution;
General description
(3GPP TS 26.267 version 9.1.0 Release 9)**



Reference

RTS/TSGS-0426267v910

Keywords

GSM, UMTS

ETSI

650 Route des Lucioles
F-06921 Sophia Antipolis Cedex - FRANCE

Tel.: +33 4 92 94 42 00 Fax: +33 4 93 65 47 16

Siret N° 348 623 562 00017 - NAF 742 C
Association à but non lucratif enregistrée à la
Sous-Préfecture de Grasse (06) N° 7803/88

Important notice

Individual copies of the present document can be downloaded from:

<http://www.etsi.org>

The present document may be made available in more than one electronic version or in print. In any case of existing or perceived difference in contents between such versions, the reference version is the Portable Document Format (PDF). In case of dispute, the reference shall be the printing on ETSI printers of the PDF version kept on a specific network drive within ETSI Secretariat.

Users of the present document should be aware that the document may be subject to revision or change of status. Information on the current status of this and other ETSI documents is available at

<http://portal.etsi.org/tb/status/status.asp>

If you find errors in the present document, please send your comment to one of the following services:

http://portal.etsi.org/chaicor/ETSI_support.asp

Copyright Notification

No part may be reproduced except as authorized by written permission.
The copyright and the foregoing restriction extend to reproduction in all media.

© European Telecommunications Standards Institute 2010.
All rights reserved.

DECTTM, **PLUGTESTS**TM, **UMTS**TM, **TIPHON**TM, the TIPHON logo and the ETSI logo are Trade Marks of ETSI registered for the benefit of its Members.

3GPPTM is a Trade Mark of ETSI registered for the benefit of its Members and of the 3GPP Organizational Partners.

LTETM is a Trade Mark of ETSI currently being registered

for the benefit of its Members and of the 3GPP Organizational Partners.

GSM[®] and the GSM logo are Trade Marks registered and owned by the GSM Association.

Intellectual Property Rights

IPRs essential or potentially essential to the present document may have been declared to ETSI. The information pertaining to these essential IPRs, if any, is publicly available for **ETSI members and non-members**, and can be found in ETSI SR 000 314: "*Intellectual Property Rights (IPRs); Essential, or potentially Essential, IPRs notified to ETSI in respect of ETSI standards*", which is available from the ETSI Secretariat. Latest updates are available on the ETSI Web server (<http://webapp.etsi.org/IPR/home.asp>).

Pursuant to the ETSI IPR Policy, no investigation, including IPR searches, has been carried out by ETSI. No guarantee can be given as to the existence of other IPRs not referenced in ETSI SR 000 314 (or the updates on the ETSI Web server) which are, or may be, or may become, essential to the present document.

Foreword

This Technical Specification (TS) has been produced by ETSI 3rd Generation Partnership Project (3GPP).

The present document may refer to technical specifications or reports using their 3GPP identities, UMTS identities or GSM identities. These should be interpreted as being references to the corresponding ETSI deliverables.

The cross reference between GSM, UMTS, 3GPP and ETSI identities can be found under <http://webapp.etsi.org/key/queryform.asp>.

Contents

Intellectual Property Rights	2
Foreword.....	2
Foreword.....	5
Introduction	5
1 Scope	6
2 References	6
3 Definitions and abbreviations.....	7
3.1 Definitions	7
3.2 Abbreviations	7
4 General overview	8
4.1 eCall system overview.....	8
4.2 eCall system requirements.....	9
4.3 eCall in-band modem architecture.....	10
4.3.1 Principle operation of the IVS data modem.....	11
4.3.2 Principle operation of the PSAP data modem.....	11
5 Functional description of the IVS data modem.....	12
5.1 IVS transmitter	12
5.1.1 MSD Message.....	12
5.1.2 CRC code.....	13
5.1.3 HARQ FEC encoder	13
5.1.3.1 Bit scrambling	13
5.1.3.2 Turbo Coding	13
5.1.3.3 HARQ for MSD messages	14
5.1.4 Modulation.....	15
5.1.5 MSD data frame format	16
5.1.6 Synchronization signal and frame format	16
5.1.7 Multiplexing	17
5.1.8 Uplink signal and retransmission.....	17
5.1.9 Additional signal format for <i>push</i> mode	18
5.2 IVS receiver.....	18
5.2.1 Synchronization detector	19
5.2.2 Timing Unit	20
5.2.3 De-multiplexing	20
5.2.4 Data demodulation and FEC decoding	20
5.2.5 Message handler	20
6 Functional description of the PSAP data modem.....	20
6.1 PSAP transmitter	20
6.1.1 Message encoding.....	21
6.1.2 BCH encoding	21
6.1.3 Modulation.....	21
6.1.4 Downlink signal.....	22
6.1.4.1 Link-layer feedback messages	22
6.1.4.2 Compressed higher-layer acknowledgement messages.....	22
6.1.4.3 Handling of downlink messages	23
6.1.5 Synchronization	23
6.1.6 Multiplexing	23
6.2 PSAP receiver	23
6.2.1 Synchronization detector	24
6.2.2 Timing Unit	24
6.2.3 De-multiplexer	24
6.2.4 Data demodulator.....	24

6.2.5	HARQ FEC decoder	25
6.2.6	CRC handling	25
6.2.7	<i>Push</i> mode - <i>push</i> message detector	25
7	Transmission protocol and error handling.....	25
7.1	Normal operation.....	25
7.2	Abnormal operation.....	26
7.3	PSAP and IVS protocol state models	29
Annex A (informative): eCall Performance Requirements/Objectives and Design Constraints.....		32
A.1	Definitions.....	32
A.2	Performance Requirements	32
A.3	Performance Objectives	34
A.4	Design Constraints	35
Annex B (informative): Change history		36
History		37

Foreword

The present document has been produced by the 3rd Generation Partnership Project (3GPP).

The contents of the present document are subject to continuing work within the TSG and may change following formal TSG approval. Should the TSG modify the contents of the present document, it will be re-released by the TSG with an identifying change of release date and an increase in version number as follows:

Version x.y.z

where:

- x the first digit:
 - 1 presented to TSG for information;
 - 2 presented to TSG for approval;
 - 3 or greater indicates TSG approved document under change control.
- y the second digit is incremented for all changes of substance, i.e. technical enhancements, corrections, updates, etc.
- z the third digit is incremented when editorial only changes have been incorporated in the document.

Introduction

eCall refers to an interoperable in-vehicle emergency call service which is envisioned to be introduced and operated across Europe in 2010. According to reports from the European Commission, it is foreseen that eCall will be offered on all new vehicles in the EU by 2010.

The European Commission has brought together standardization bodies, the automotive industry, mobile telecommunication industry, public emergency authorities and others in the eSafety Forum initiative which has identified high-level requirements, recommendations and guidelines for this eCall service [9] and [10]. The eSafety Forum has assigned ETSI MSG to standardize those parts of the eCall service that affect the mobile communication system. The development of the eCall standard has been further delegated to the 3rd Generation Partnership Project (3GPP).

1 Scope

The present document specifies the eCall In-band Modem, which is used for reliable transmission of the eCall Minimum Set of Data (MSD) from an In-Vehicle System (IVS) to the Public Safety Answering Point (PSAP) via the voice channel of cellular and PSTN networks.

The European Union eCall requirements, recommendations and guidelines were developed by eSafety Forum [10] and [11], with important additional work produced by ETSI MSG, GSME, 3GPP, and CEN.

Previous work in 3GPP TR 22.967 [3] "Transfer of Emergency Call Data", examined the issues associated with the transmission of emergency call data from a vehicle to a PSAP. This analysis identified that the preferred option be based on an in-band modem solution.

eCall provides reliable full-duplex data communications between IVS and PSAP in addition to emergency voice call (E112) via the cellular network, and can be initiated either automatically or manually [1]. The eCall In-band Modem uses the same voice channel as used for the emergency voice call. eCall allows reliable transmission of MSD alternating with a speech conversation through the existing voice communication paths in cellular mobile phone systems. The expected benefit is that emergency services will be made aware of accidents much more rapidly, will get precise information on location, vehicle type etc. and therefore will be able to reach accident victims faster, with the potential to save many lives annually.

The eCall in-band modem solution described here exceeds the eCall requirements (see Annex A) by means of a combination of innovations in data modulation scheme, synchronization, forward error correction coding, hybrid ARQ (HARQ) and incremental redundancy transmission.

The present document provides a general overview and algorithm description of the eCall in-band modems, including IVS modem and PSAP modem, to form the complete full-duplex transmission.

The eCall in-band modems (IVS and PSAP) are fully specified by this TS together with the C-code reference as provided in 3GPP TS 26.268 [2].

3GPP TS 26.269 [13] deals with the conformance testing for eCall modem implementations, and 3GPP TR 26.969 [14] contains a characterization report of the in-band modem.

2 References

The following documents contain provisions which, through reference in this text, constitute provisions of the present document.

- References are either specific (identified by date of publication, edition number, version number, etc.) or non-specific.
- For a specific reference, subsequent revisions do not apply.
- For a non-specific reference, the latest version applies. In the case of a reference to a 3GPP document (including a GSM document), a non-specific reference implicitly refers to the latest version of that document *in the same Release as the present document*.

- [1] 3GPP TS 22.101: "Service aspects; Service principles".
- [2] 3GPP TS 26.268: "eCall Data Transfer; In-band modem solution; ANSI-C reference code".
- [3] 3GPP TR 22.967: "Transfer of Emergency Call Data".
- [4] 3GPP TR 26.967: "eCall Data Transfer; In-band modem solution".
- [5] 3GPP TS 46.001: "Full rate speech; Processing functions".
- [6] 3GPP TS 46.032: "Full rate speech; Voice Activity Detection (VAD) for full rate speech traffic channels".

- [7] 3GPP TS 26.071: "AMR speech Codec; General description".
- [8] 3GPP TS 26.094: "Mandatory speech codec speech processing functions; Adaptive Multi-Rate (AMR) speech codec; Voice Activity Detector (VAD)".
- [9] eSafety Forum eCall Driving Group, "European Memorandum of Understanding for Realisation of Interoperable In-Vehicle eCall", May 2004.
- [10] eSafety Forum, "Clarification Paper – EG.2 , High level requirements for a eCall in-vehicle system, Supplier perspective", March 2006, Version 1.0.
- [11] eSafety Forum, "Recommendations of the DG eCall for the introduction of the pan-European eCall", April 2006, Version 2.0.
- [12] 3GPP TS 26.226: "Cellular text telephone modem; General description".
- [13] 3GPP TS 26.269: "eCall Data Transfer; In-band modem solution; Conformance testing".
- [14] 3GPP TR 26.969 " eCall Data Transfer; In-band modem solution; Characterization report".

3 Definitions and abbreviations

3.1 Definitions

For the purposes of the present document, the following terms and definitions apply:

eCall: A manually or automatically initiated emergency call (TS12) from a vehicle, supplemented with a minimum set of emergency related data (MSD), as defined under the EU Commission's eSafety initiative.

eCall In-band Modem: Modem pair (consisting of transmitters and receivers at IVS and PSAP) that operates full-duplex and allows reliable transmission of eCall Minimum Set of Data from IVS to PSAP via the voice channel of the emergency voice call through cellular and PSTN networks.

eSafety: European Commission sponsored forum to improve safety aspects of European citizens.

feedback frame: Downlink signal transmission interval containing feedback data - corresponds to a time interval of 140 ms or 1 120 samples at an 8 kHz sampling rate.

frame (or: speech frame): Time interval equal to 20 ms (corresponding to one AMR or FR speech frame, represented by 160 samples at an 8 kHz sampling rate).

MSD: The Minimum Set of Data forming the data component of an eCall sent from a vehicle to a Public Safety Answering Point or other designated emergency call centre. The MSD has a maximum size of 140 bytes and includes, for example, vehicle identity, location information and time-stamp.

MSD data frame: Uplink signal transmission interval containing the data of one MSD (after synchronization has been established) - corresponds to a time interval of 1 080 ms or 8 640 samples (fast modulator) and 2 080 ms or 16640 samples (robust modulator) assuming an 8 kHz sampling rate.

modulation frame: Symbol transmission time interval equal to 2 ms corresponding to 16 samples at 8 kHz sampling rate (fast modulator), or 4 ms corresponding to 32 samples at 8 kHz sampling rate (robust modulator).

synchronization frame: Signal transmission interval containing synchronization information - corresponds to a time interval of 260 ms or 2 080 samples at an 8 kHz sampling rate.

3.2 Abbreviations

For the purposes of the present document, the following abbreviations apply.

ACK	ACKnowledgement
AMR	Adaptive Multi-Rate (speech codec)

BCH	Bose-Chaudhuri-Hocquenghem (Code)
BP	Band Pass
CRC	Cyclic Redundancy Check
CTM	Cellular Text telephone Modem
eIM	eCall In-band Modem
EU	European Union
FEC	Forward Error Correction
FR	Full Rate (speech codec)
GSM	Global System for Mobile communications
HARQ	Hybrid Automatic Repeat-reQuest
IR	Incremental Redundancy
IVS	In-Vehicle System
LP	Low Pass
MSD	Minimum Set of Data
NACK	Negative ACKnowledgement
PCCC	Parallel Concatenated Convolutional Code
PCM	Pulse Code Modulation
PSAP	Public Safety Answering Point
PSTN	Public Switched Telephone Network
ROM	Read Only Memory
RV	Redundancy Version
SF	Synchronization Frame
UMTS	Universal Mobile Telecommunications Systems
VAD	Voice Activity Detection

4 General overview

4.1 eCall system overview

The eCall system overview is depicted in Figure 1.

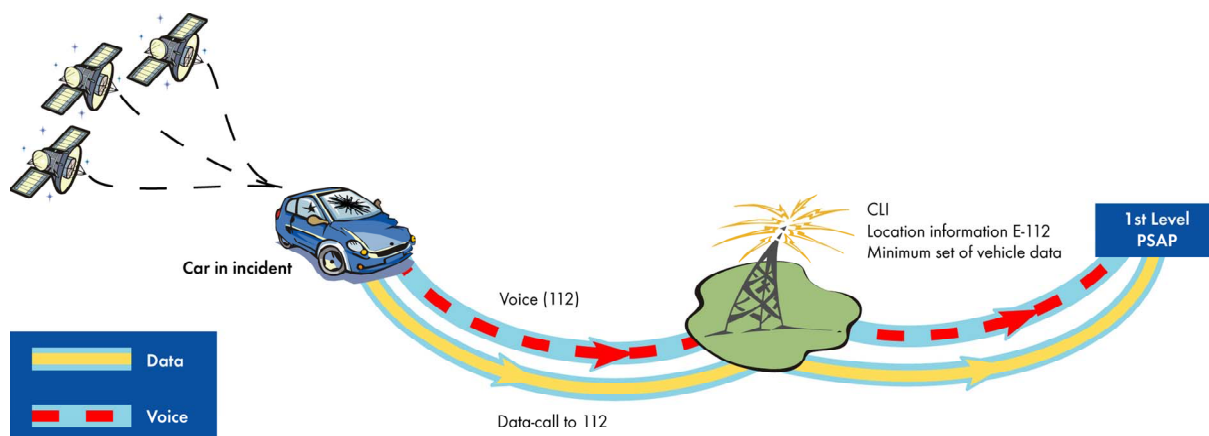

Figure 1: eCall system overview [11]

In the event of a vehicle collision, the eCall in-band modem solution is used in an automatically or manually established emergency voice call (E112) from the vehicle (IVS) via the cellular network to the local emergency agencies, i.e. the PSAP. The eCall modem allows to transfer a data message from the IVS over the cellular network to the PSAP which is denoted as eCall MSD. The MSD can include, e.g. vehicle location information, time stamp, number of passengers, Vehicle Identification Number (VIN), and other relevant accident information.

It is expected that the eCall MSD information will be sent either immediately following the establishment of the voice call or at any point later during the voice call. The integrity of the eCall data sent from the vehicle to the PSAP is ensured by the specified modem.

eCall is a European regional requirement. It shall not have an impact on the global circulation of terminals.

4.2 eCall system requirements

The eCall service requirements have been defined in 3GPP TS 22.101 [1], and are reproduced here for information. Not all of the requirements apply to the eCall modem specification in this document.

- The data may be sent prior to, in parallel with, or at the start of the voice component of an emergency call.
- Should the PSAP request additional data then this may be possible during the established emergency call.
- The realisation of the transfer of data during an emergency call shall minimise changes to the originating and transit networks.
- Both the voice and data components of the emergency call shall be routed to the same PSAP or designated emergency call centre.
- The transmission of the data shall be acknowledged and if necessary data shall be retransmitted.
- A UE configured only to transfer data during emergency calls (e.g. eCall only UE) shall not generate signalling to the network besides what is needed to place an emergency call.
- The UE shall indicate at call setup if the emergency call will carry supplementary data.

The following specific requirements are considered necessary for the satisfactory operation of the eCall service. Additionally, all existing TS12 emergency call requirements shall apply.

- An eCall shall consist of a TS12 emergency call supplemented by a minimum set of emergency related data (MSD).
- An eCall may be initiated automatically, for example due to a vehicle collision, or manually by the vehicle occupants.
- An IVS, or other UE designed to support eCall functionality, shall include in the emergency call set-up an indication that the present call is either a Manually Initiated eCall (MIeC) or an Automatically Initiated eCall (AIeC).
- The Minimum Set of Data (MSD) sent by the In vehicle System (IVS) to the network shall not exceed 140 bytes.
- The MSD should typically be made available to the PSAP within 4 seconds, measured from the time when end to end connection with the PSAP is established.
- Should the MSD component not be included in an eCall, or is corrupted or lost for any reason, then this shall not affect the associated TS12 emergency call speech functionality.
- A call progress indication shall be provided to the user whilst the MSD transmission is in progress.
- To reduce the time taken to establish an eCall an IVS whilst in eCall only mode, may receive network availability information whilst not registered on a PLMN.
- Optionally, PLMNs may make use of eCall indicators, received in the emergency call set-up, to differentiate eCalls from other TS12 emergency calls.
- The MIeC and AIeC may be used to filter or route eCalls to a dedicated PSAP operators.

Throughout the duration of the emergency call and following receipt of the MSD by the PSAP

- It shall be possible for the PSAP to send a confirmation to the IVS that the MSD has been acted upon.
- It shall be possible for the PSAP to request the IVS to re-send its most recent MSD.
- It shall be possible for the PSAP to instruct the IVS to terminate the eCall.

For the purpose of selecting the best performing eIM solution, these service requirements have been further clarified, and performance objectives under different radio channel conditions as well as design constraints are defined in Annex A.

4.3 eCall in-band modem architecture

It is a challenging task to transmit data over the mobile voice channel as required of an in-band modem since speech codecs used in digital cellular systems are optimized explicitly for speech signal compression. Therefore, modem signals may incur heavy distortion after passing through the effective transmission channel consisting of speech codec, possible degradations on the radio channel, and speech decoder with error concealment. Furthermore, in digital cellular communications frame losses occur regularly and increase the burden of data recovery by the in-band modem.

CTM was developed in 3GPP for transmitting text data for text telephony. It was evaluated as a potential solution for eIM in the technical report (3GPP TR 26.967 [4]) and found not able to meet eCall requirements.

The present eIM solution consists of an IVS data modem and a PSAP data modem, employing signals that have been designed to pass through modern speech codecs with only moderate distortion, yet providing sufficiently high data rates for quick MSD transmission.

The overall cellular system architecture, including the IVS and PSAP data modems, is given for information in a simplified diagram in Figure 2.

After an emergency voice call has been (automatically or manually) established, the IVS modem receiver constantly monitors the incoming signal from the speech decoder output. When prompted by a request from the PSAP operator for MSD, the IVS connects the IVS data modem transmitter to the input of the speech coder and mutes any speech from the motorist for the duration of MSD transmission to prevent it from interfering with the eCall data transmission. Alternatively, it can be the IVS that may trigger the MSD transmission. In this case, the IVS asks the PSAP to request an MSD transmission.

The first operation mode shall be referred to as the *pull* mode whereas the latter one is the *push* mode. Essentially, push mode is realized by a request from the IVS to the PSAP to *pull* the MSD.

The requirement about the modem to be configured in either *push* or *pull* mode is beyond the scope of this specification. Refer to clause 4.2 for a reproduction of eCall service requirements.

In general, the microphone has to be detached from the signal path whenever the eCall modem is actively transmitting.

The operational principles of the IVS and PSAP modems within the environment illustrated in Figure 1 are further explained in the following. Details of the employed algorithms and functions are given in clauses 5 and 6.

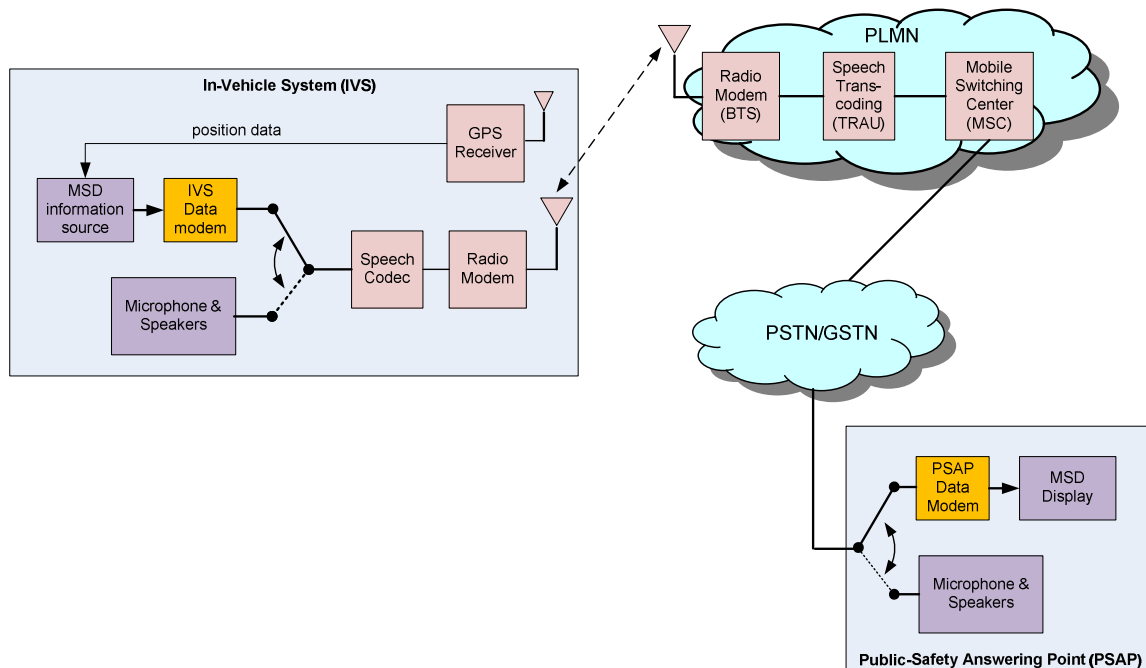

Figure 2: eCall system within the cellular system architecture

4.3.1 Principle operation of the IVS data modem

The main components of the IVS data modem are illustrated in Figure 3. The MSD information input into the IVS transmitter is first appended with CRC information. These bits are then encoded in the hybrid ARQ (HARQ) encoder using FEC coding to reduce the susceptibility to transmission errors. The HARQ encoder employs a powerful state-of-the-art turbo encoding scheme with incremental redundancy added for each retransmission. The signal modulator converts the encoded data into waveform symbols which are especially suitable for transmission through speech codecs employed in present mobile systems, including the GSM Full-Rate (3GPP TS 46.001 [5]) and the various modes of AMR codecs (3GPP TS 26.071 [7]).

The IVS receiver continues to monitor the feedback messages from the PSAP data modem. As long as the received feedback messages are NACK messages, retransmissions of the MSD with incremental redundancy are automatically continued until an ACK message set (containing a link-layer ACK message and a compressed higher-layer ACK message from the application layer) is received by the IVS, or operation is terminated by the PSAP. After the transmission of the MSD information and the higher-layer ACK message is completed, the eCall modem transmitters in both the IVS and PSAP return to idle state and the signal paths from the transmitters are switched off to avoid interference with the normal voice call.

In *push* mode, the IVS reuses the downlink message format for requesting the PSAP to *pull* the MSD. Request messages are transmitted until the IVS receiver detects *START* messages from the PSAP or a timeout occurs. Upon detection of the *START* messages the IVS continues as if it was in *pull* mode.

This document only specifies the eCall modem for the transmission of one MSD of length 140 bytes. Messages shorter than 140 bytes are assumed to have been padded, e.g., with zeros before being fed to the IVS transmitter. Longer message lengths would require a packet segmentation mechanism as well as adaptations to the transmission protocol, which are out of scope for this document.

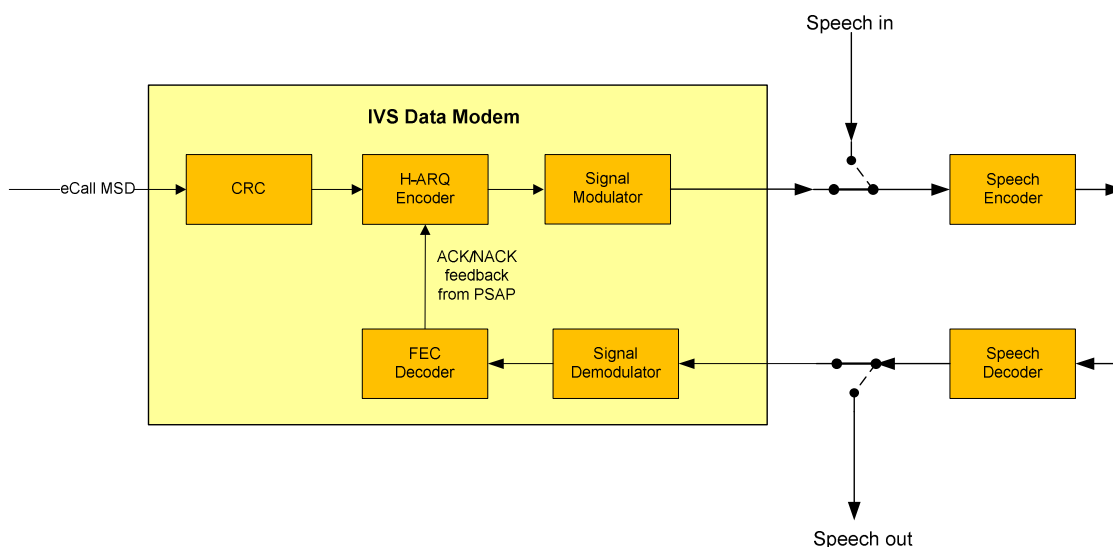

Figure 3: eCall IVS data modem overview

4.3.2 Principle operation of the PSAP data modem

The main components of the PSAP data modem are illustrated in Figure 4. After having triggered the IVS data modem for transmission of MSD, the eCall PSAP receiver continuously monitors the incoming signal from the PSTN. When the eCall data signal is detected and synchronized, the signal demodulator demodulates the incoming data symbols. The HARQ decoder soft-combines the first MSD transmission with any retransmissions of the information and decodes the FEC to determine the information bits, i.e. its estimate of the CRC protected MSD information. If a CRC error is detected in the decoded MSD, the PSAP receiver returns NACK and thereby prompts the IVS transmitter to provide retransmissions with incremental redundancy. Otherwise, the MSD information is provided to the PSAP operator and the IVS transmitter is notified with link-layer ACK messages that retransmissions are no longer required. To conclude the MSD transmission sequence, a compressed higher-layer ACK message (received from the application layer) is repeatedly transmitted from the PSAP to the IVS.

In *push* mode, the PSAP monitors the received signal for a trigger from the IVS. Upon detection of a trigger it transmits a request for MSD transmission as it would do in *pull* mode and continues as described above.

The incoming speech path is switched off when the PSAP transmitter needs to use the voice channel for feedback messages. Once the MSD is correctly received and the compressed higher-layer ACK message is transmitted, the speech path is unmuted to avoid interference with the normal voice call.

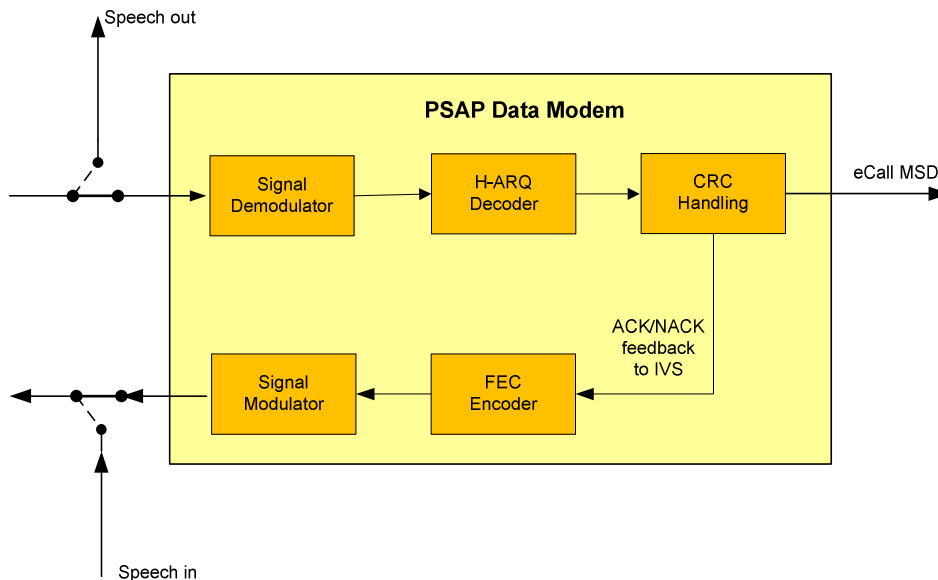

Figure 4: eCall PSAP data modem overview

5 Functional description of the IVS data modem

This clause describes the different functions of the IVS data modem.

5.1 IVS transmitter

The IVS transmitter modulates the MSD data to generate signals suitable for transmission over the in-band voice channel to the PSAP. The different blocks of the IVS transmitter are shown in Figure 5.

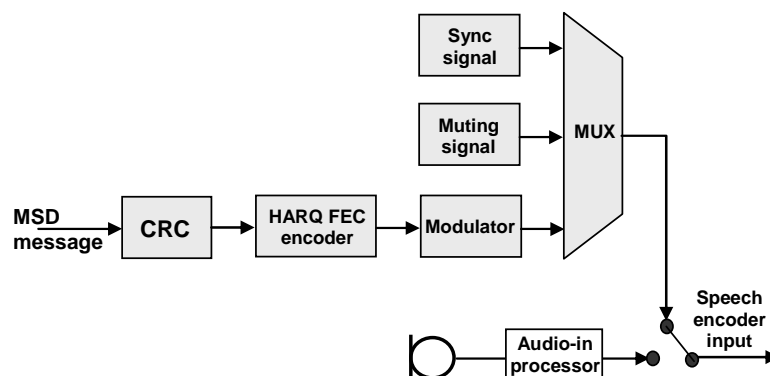

Figure 5: IVS transmitter block diagram

5.1.1 MSD Message

The MSD is represented by a field of 140 bytes (1 120 bits).

The MSD is denoted a_i , $i = 1, \dots, 1120$.

5.1.2 CRC code

Each MSD message is appended by a field of 28 bit CRC code prior to HARQ FEC encoding.

The entire MSD of length $K = 1120$ bits is used to calculate the CRC parity bits. The length of the CRC protected code word is $N = 1148$. Then $N - K = 28$ denotes the degree of the generator polynomial.

The parity bits are generated by the following cyclic generator polynomial:

$$g_{CRC28}(D) = D^{28} + D^{26} + D^{24} + D^{23} + D^{18} + D^{17} + D^{16} + D^{15} + D^{14} + D^{11} + D^8 + D^4 + D^3 + 1$$

Denote the bits in the MSD by a_1, a_2, \dots, a_K and the parity bits by p_1, p_2, \dots, p_{28} .

The encoding is performed in a systematic form, which means that in GF(2), the polynomial

$$a_1 D^{K+27} + a_2 D^{K+26} + \dots + a_K D^{28} + p_1 D^{27} + p_2 D^{26} + \dots + p_{27} D^1 + p_{28}$$

yields a remainder equal to 0 when divided by $g_{CRC28}(D)$.

5.1.3 HARQ FEC encoder

HARQ FEC encoding includes bit scrambling, turbo coding, and the HARQ scheme.

5.1.3.1 Bit scrambling

Bit scrambling is applied to the CRC appended MSD prior to turbo encoding:

$$a_s(i) = a_{crc}(i) \text{ XOR } b_{scm}(i), \quad i = 0, \dots, 1147$$

Where a_{crc} is the MSD and CRC bitstream, and b_{scm} is the scrambling sequence.

5.1.3.2 Turbo Coding

The native scheme of the deployed Turbo encoder is a Parallel Concatenated Convolutional Code (PCCC) with two identical 8-state constituent encoders with the polynomial

$$g_0(D) = g_1(D) = 1 + D^2 + D^3,$$

and one Turbo code internal interleaver. The resulting coding rate of the Turbo coder is $r = 1/3$. The structure of the Turbo coder is illustrated in Figure 6. The initial value of the shift registers of the 8-state constituent encoders are set to zeros prior to encoding the MSD. The bits output from the Turbo code internal interleaver are to be input to the second 8-state constituent encoder.

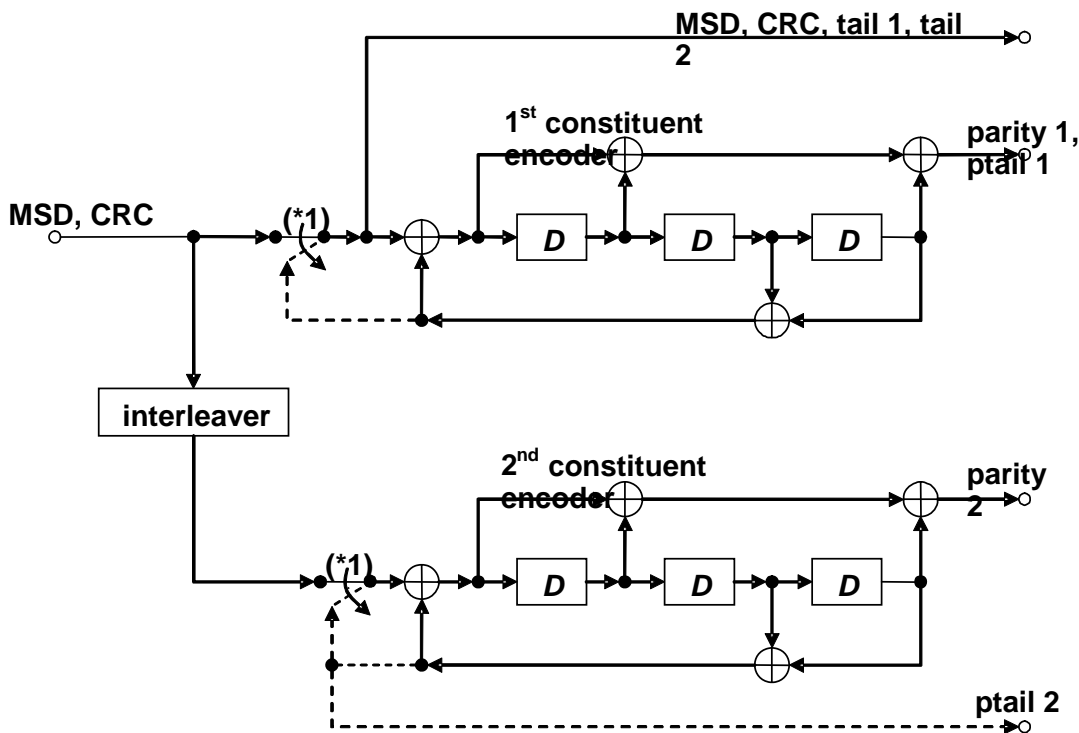

Figure 6: Structure of a rate 1/3 Turbo coder (*1: dotted lines apply for trellis termination only)

Trellis termination is performed by taking the tail bits from the shift register feedback after all information bits are encoded. Tail bits are padded after the encoding of information bits. The first three tail bits are used to terminate the first constituent encoder (upper switch in Figure 4 in lower position) while the second constituent encoder is disabled. The last three tail bits are used to terminate the second constituent encoder (lower switch of Figure 6 in lower position) while the first constituent encoder is disabled.

The Turbo code internal interleaver consists of bits-input to a rectangular matrix with padding, intra-row and inter-row permutations of the rectangular matrix, and bits-output from the rectangular matrix with pruning [2].

The parity blocks are generated with the same convolutional encoder, and 3 tail bits are generated from the FEC encoder states [2].

The encoder outputs are collected in the channel coded bit buffer according to Figure 7.

MSD+CRC	tail ₁	tail ₂	Parity 1	ptail ₁	Parity 2	ptail ₂
---------	-------------------	-------------------	----------	--------------------	----------	--------------------

Figure 7: Channel coded bit buffer

5.1.3.3 HARQ for MSD messages

The applied HARQ scheme can create eight different redundancy versions (RV), *rv0* ... *rv7*, from the channel coded bit buffer. Each one of the RV consists of a subset of 1380 bits from the channel coded bit buffer. *rv0*, *rv2*, *rv4*, and *rv6* contain the entire MSD+CRC part of the channel coded bit buffer. The maximum code rate of the coding scheme is $r_{eff} \approx 0.83$ since the MSD and CRC are 1148 bit altogether. The redundancy is increased with every further transmission of RVs.

The generation of different redundancy versions of the MSD from the above FEC encoded bitstream is defined in ROM tables and can be found in 3GPP TS 26.268 [2].

5.1.4 Modulation

The encoded binary data stream bits b_i are grouped into symbols. Each symbol d_j carries 3 bits of information and modulates one basic uplink waveform which corresponds to one modulation frame.

There are two modulator modes, a fast modulator mode and a robust modulator mode. Under normal conditions, a transmission is successful when applying the fast modulator mode. The robust modulator mode serves as a back up solution if a transmission fails in unusually difficult environments. The modulator modes merely differ by symbol duration, i.e., the length of the modulation frames, which is 2 ms for the fast modulator mode and 4 ms for the robust modulator mode. In terms of samples this is 16 samples for the fast modulator mode and 32 samples for the robust modulator mode at 8 kHz sampling rate. Therefore, a speech frame accommodates 10 modulation frames (containing 10 symbols, or 30 bit) for the fast modulator mode and 5 modulation frames (5 symbols or 15 bit) for the robust modulator mode. Hence, the modulation data rates are 1 500 bit/s and 750 bit/s, respectively, not accounting for muting gaps and synchronization frames.

The uplink waveform is determined by the basic uplink waveform $p_{UL}(n)$, which is

$$p_{UL}(n) = (0, 0, 0, 40, -200, 560, -991, -1400, 7636, 15000, 7636, -1400, -991, 560, -200, 40)$$

for the fast modulator mode ($n = 0, \dots, 15$) and

$$p_{UL}(n) = (0, 0, 0, 0, 0, 40, -200, 560, -991, -1400, 7636, 15000, 7636, -1400, -991, 560, -200, 40, 0, 0, 0, 0, 0, 0, 0, 0, 0, 0, 0, 0, 0, 0, 0)$$

for the robust modulator mode ($n = 0, \dots, 31$). These values are given with respect to a signed 16-bit signal representation. The mapping between the symbol d_j and the uplink waveform is given by a cyclic right-shift of k samples, denoted by $(p \rightarrow k)$, and the sign q of the basic uplink waveform $p_{UL}(n)$. Table 1 details this mapping. Note that the position (cyclic shift) of the waveform carries two bits of information while the sign of the waveform adds another bit of information. Figure 8 illustrates the slot structure of both modulator modes. It represents a particular example symbol sequence in an abstract way by neglecting the actual shape and signs of the waveforms. The large bars indicate the maxima of the basic uplink waveforms according to the example symbols whereas the small ones indicate the other potential maximum positions.

Table 1: Symbol modulation mapping for uplink

Symbol		uplink waveform fast modulator mode $w_{UL}(n) = q \cdot (p(n) \rightarrow k)$ ($n = 0, \dots, 15$)		uplink waveform robust modulator mode $w_{UL}(n) = q \cdot (p(n) \rightarrow k)$ ($n = 0, \dots, 31$)	
d_j	b_i	sign q	cyclic shift k	sign q	cyclic shift k
0	000	1	0	1	0
1	001	1	4	1	8
2	010	1	8	1	16
3	011	1	12	1	24
4	100	-1	12	-1	24
5	101	-1	8	-1	16
6	110	-1	4	-1	8
7	111	-1	0	-1	0

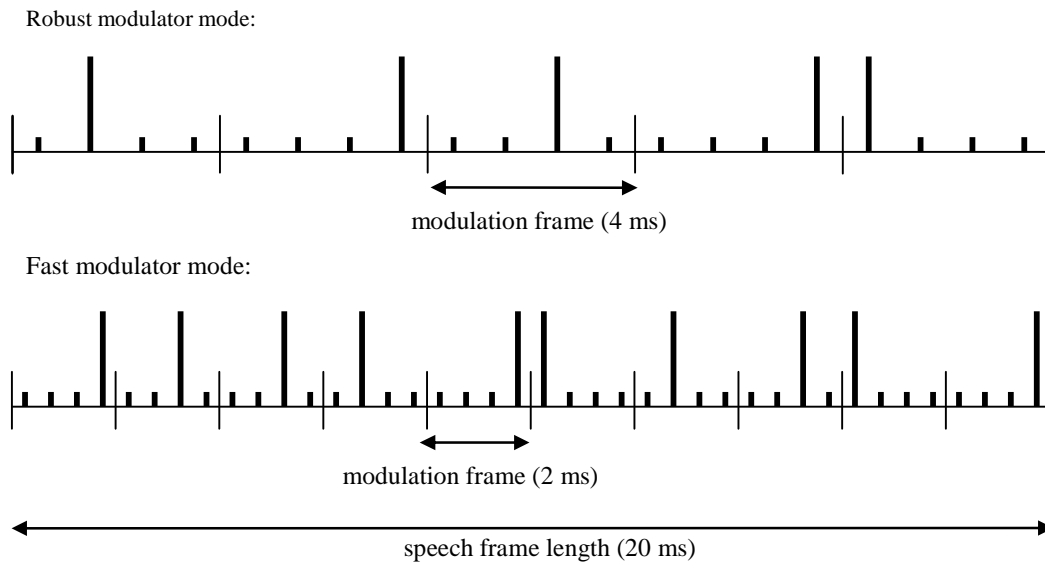

Figure 8: Slot structure of uplink modulator

5.1.5 MSD data frame format

Each MSD data frame includes one encoded MSD message with CRC field, split up into multiple data fields.

The MSD data frame forms the largest fraction of uplink data traffic and consists of three data fields, and four muting gaps, arranged as given in Table 2a.

Table 2a: MSD data frame format

Pos.	Fast modulator mode	Robust modulator mode
1	1 frame of muting, M1 (20 ms)	1 frame of muting, M1 (20 ms)
2	15 frames of modulated data, D1 (300 ms)	30 frames of modulated data, D1 (600 ms)
3	2 frames of muting, M2 (40 ms).	4 frames of muting, M2 (80 ms).
4	15 frames of modulated data, D2 (300 ms).	30 frames of modulated data, D2 (600 ms).
5	2 frames of muting, M3 (40 ms)	4 frames of muting, M3 (80 ms)
6	16 frames of modulated data, D3 (320 ms)	32 frames of modulated data, D3 (640 ms)
7	3 frames of muting, M4 (60 ms)	3 frames of muting, M4 (60 ms)
Sum	54 frames (1 080 ms)	104 frames (2 080 ms)

5.1.6 Synchronization signal and frame format

The synchronization frame consists of the direct concatenation of:

- 1) the synchronization tone $s_t(n)$; and
- 2) the synchronization preamble $s_p(n)$.

The synchronization tone $s_t(n)$ consists of a sampled sinusoidal tone of frequency 500 Hz or 800 Hz, and of 64 ms duration. A frequency of 500 Hz is chosen to indicate that the fast modulator mode is to be applied and a frequency of 800 Hz indicates that the robust modulator mode is used for the subsequent MSD frames.

The synchronization tone $s_t(n)$ is followed by synchronization preamble $s_p(n)$. The synchronization preamble is a pulse sequence known at the receiver. The pulse sequence for the synchronization preamble has been chosen to optimize autocorrelation properties in order to allow a very reliable detection and delay estimation at the same time. The achieved accuracy of the delay estimation is typically exact by sample.

The basis of the synchronization preamble $s_p(n)$ is a PN sequence of length 15 that takes values of (1, 1, 1, 1, -1, 1, -1, 1, 1, -1, -1, 1, -1, -1, -1). Each pulse has an amplitude of 20000 in a signed 16-bit signal representation. The pulse sequence is composed of 5 periods of this PN sequence. The outer periods (number 1 and 5) are inverted (i.e. all elements are multiplied with -1) and those parts that are common to the inverted and non inverted sequence are transmitted just once, see Figure 9. Figure 10 illustrates the resulting pulse sequence.

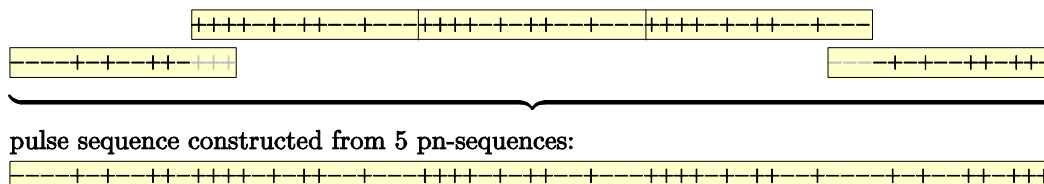

Figure 9: Construction of pulse sequence for the sync preamble (+ := +1 and - := -1)

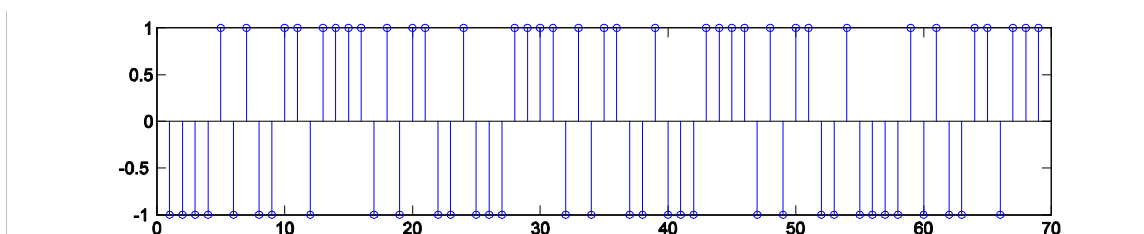

Figure 10: Pulse sequence for generation of synchronization preamble

In the pulse sequence, neighboring pulses are placed 22 samples apart to form the synchronization preamble, i.e. zero-padding of 21 zero samples between pulses is applied. In addition, 71 zero samples are placed before the first pulse. The resulting synchronization preamble has a duration of $71 + 69 + (68 \cdot 21) = 1568$ samples, or 196 ms.

Both synchronization tone $s_t(n)$ and synchronization preamble $s_p(n)$ can be stored in a ROM table to avoid computation at runtime. These tables can be found in 3GPP TS 26.268 [2], and they should serve as a reference of the synchronization signal..

The overall length of the synchronization frame is 13 frames or 260 ms.

5.1.7 Multiplexing

The multiplexer combines the synchronization frame, muting frames and MSD data frames to the effective transmit signal as in Figure 11.

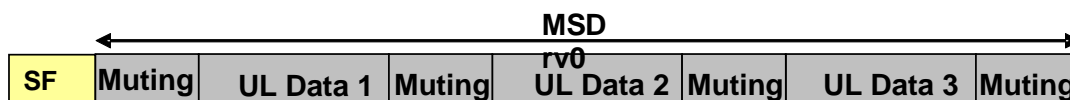

Figure 11: Uplink data format with multiplexing

5.1.8 Uplink signal and retransmission

The uplink signal starts with a synchronization frame (SF) which is succeeded by one or more MSD redundancy versions, e.g. MSD rv_0 , MSD rv_1 , MSD rv_2 , etc. as shown in Figure 12.

MSD *rv0* is the first transmission of a full MSD message. MSD *rv1* represents the first retransmission, MSD *rv2* the second retransmission, each with a different version of incremental redundancy (IR). Up to eight different versions of incremental redundancy are allowed (MSD *rv0* ... MSD *rv7*).

In good channel conditions, the MSD should be successfully decodable after the reception of the first transmission, MSD *rv0*.

The IVS transmitter stops transmitting when an ACK message is received on the downlink by the IVS receiver.

If, after one transmission attempt (consisting of 8 RV transmissions), the MSD message is still not received correctly, the MSD transmission cycle is started again with one synchronization frame and MSD *rv0*, using the robust modulator mode. The PSAP receiver resets the IR combining buffer after 8 received MSD messages, switches the demodulation mode, and restarts combining again.

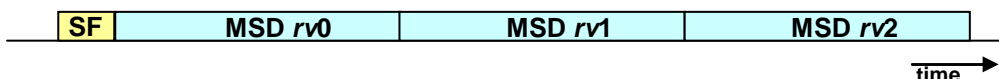

Figure 12: Uplink signal format

The generation of different redundancy versions of the MSD is defined in ROM tables and can be found in 3GPP TS 26.268 [2].

5.1.9 Additional signal format for *push* mode

If the IVS is to issue the request for MSD transmission, it reuses the downlink signal format according to clause 6.1. The message used for the data part is reproduced in Table 2b. The modulated data may be precomputed and stored in the IVS ROM. Several such messages are transmitted before an IVS state change triggers the MSD transmission, or a timeout occurs.

Table 2b: Uplink *push* message encoding

Message	Binary representation	BCH encoder output, <i>b_i</i> (hexadecimal)*
push (IVS initiation message)	0011	DBE 9397 9461 07EA

*: see clause 6.1 for encoding scheme

5.2 IVS receiver

The IVS receiver demodulates and decodes feedback messages (START, NACK, link-layer ACK, and compressed higher-layer ACK) from the PSAP. It starts the IVS transmitter after detecting a request message (the START trigger) for MSD data transmission on the downlink. The different blocks of the IVS receiver are shown in Figure 13.

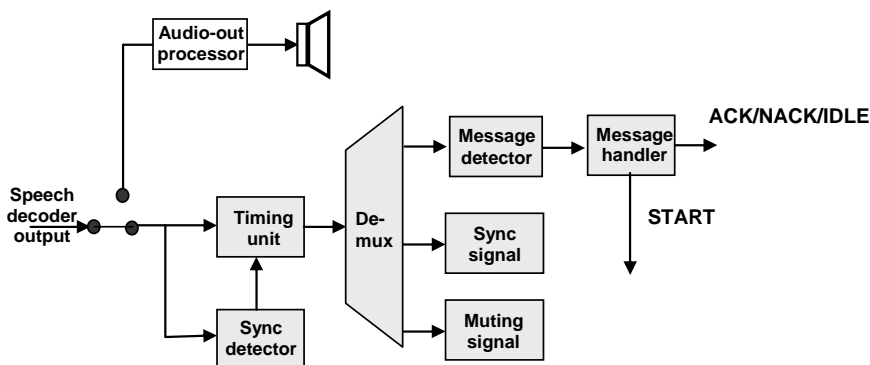

Figure 13: IVS receiver block diagram

5.2.1 Synchronization detector

For support of the synchronization/detection function, each synchronization frame includes two parts, which are denoted as synchronization tone and synchronization preamble as described in clause 5.1.6.

NOTE: The downlink synchronization frame is identical to the uplink synchronization frame (except that the downlink only uses a frequency of 500 Hz for the synchronization tone), however, the data frame formats are different in uplink and downlink.

The synchronization detector has two main functions:

- 1) Scan the input signal and identify the start of an eCall data transmission. The result of this operation is a synchronization detection flag which indicates whether or not eCall data transmission has been detected.
- 2) Determine the timing of the data frame. The result of this operation is timing information from which the location of the data burst in the input signal can be calculated at sample resolution.

To avoid false detection of an eCall data transmission in the IVS receiver, the synchronization detector evaluates three consecutive sync frames. It sets the detection flag $DF = 1$, only if the same timing information is detected in three successively detected sync preambles. This feature is also required to prevent misdetection of the START message and to keep the synchronization failure rate at virtually zero.

The synchronization preamble sequence in Figure 10 is constructed to have good autocorrelation properties for optimal detection as shown in Figure 14.

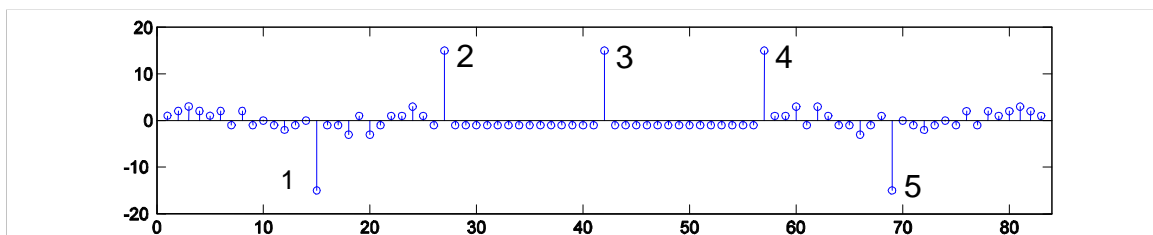

Figure 14: Autocorrelation properties of pulse sequence of Figure 10

The synchronization algorithm acquires the delay value by checking the correctness of the distance between the five correlation peaks. A preamble is considered detected if either the pair of peaks (2, 4) or the pair of peaks (1, 5) exhibit correct distances from each other, provided that they fulfil certain amplitude constraints (the amplitude differences shall not differ by more than a factor of 3 and their average shall not be less than half of the global maximal sync filter output since first activation of the synchronization detector). Additionally, a preamble is also considered detected if any four peaks are detected without significant amplitude constraints except for a global threshold.

To distinguish between compressed higher-layer ACK message and link-layer ACK messages on the downlink, an inverted sync pulse sequence precedes the compressed higher-layer ACK messages. The synchronization detector determines the signs of the autocorrelation pulses independently from the absolute peak values and peak distances. If the IVS has already detected a lower layer acknowledgement for the current MSD, the correlation peak signs are used to determine whether the incoming feedback message is a link-layer ACK or compressed higher-layer ACK message. If an inverted sign of autocorrelation pulses is detected right from the beginning of uplink and/or downlink transmissions, the synchronization detector assumes that a signal inversion is occurring on the transmission path. In this case, all received PCM samples are multiplied by -1 on the affected link for the remainder of the MSD transmission.

Because feedback messages are transmitted continuously on the downlink, it is usually sufficient for the IVS receiver to perform the synchronization only once per MSD. This means, synchronization can be locked once an eCall data transmission has been detected and the timing information has been computed. Nevertheless, there exist rare scenarios that may require a resynchronization due to lost synchronization, e.g. because of an adaptive jitter buffer. Therefore, the correctness of the synchronization is checked continuously (referred to as "Sync Check") by evaluating the correlation at the expected peak positions for any of the feedback messages. The data part of a message is ignored if all five peak values are significantly below the average peak amplitude that triggered the original synchronization event. If this happens 8 times in a row, the IVS resets itself.

5.2.2 Timing Unit

The timing unit adjusts the timing of the received signal for the following processing stages according to the timing information obtained by the synchronization detector.

5.2.3 De-multiplexing

The de-multiplexer removes the muting and synchronization signals from the input data stream.

5.2.4 Data demodulation and FEC decoding

The data demodulator and decoder on the downlink are represented by a single correlator matched directly to the modulated downlink waveforms. The received waveform is correlated to each of the stored waveforms and a maximum likelihood decision on the feedback message, *msg*, is made.

$$metric(k) = \sum_{i=0}^{479} pcm_data(i) * dlPcmMatch(k)(i), k = 0,1,2,3$$

$$msg = \arg \max_k metric(k)$$

Since only a very small number of different data messages (see Table 3) is used on the downlink, the entire expected signal patterns can be stored at the IVS receiver. These patterns have a length of 480 samples each (corresponding to 60 ms, which is the length of modulated feedback messages). In the demodulator/decoder the cross-correlation between the received signal and the stored pattern for each possible transmit message is calculated, and a decision for a message is made according to individual correlation thresholds. If synchronization has detected a message, but the demodulator threshold is not reached for either of the valid messages, the message is marked as unreliable and ignored in the case of lower-layer ACK or NACK. In case of START, the first six unreliable messages are ignored, but subsequent unreliable messages are not distinguished from reliable ones any more. The compressed higher-layer ACK is considered as successfully received if three consecutive messages (irrespective of reliability), or two reliable, consecutive messages, are detected with identical data.

5.2.5 Message handler

This function activates the appropriate functions in the IVS modem according to the message received. If the START message is received, the IVS transmitter is activated to send MSD data to the PSAP. If NACK messages have been received prior to the START messages, it requires at least 3 consecutive reliable START messages to restart the IVS transmitter. If NACK is received, retransmission starts automatically with incremental redundancy. Two subsequent link-layer ACK messages simply instruct the IVS transmitter to stop transmission and wait for the compressed higher-layer ACK message. Also, if the Sync Check fails to detect the preamble, the IVS transmitter is reset to idle state.

6 Functional description of the PSAP data modem

This clause describes the different functions of the PSAP data modem.

6.1 PSAP transmitter

The PSAP transmitter generates the signal sent on the downlink. This signal is required to control the transmission of the MSD message on the uplink. The different blocks of the PSAP transmitter are shown in Figure 15.

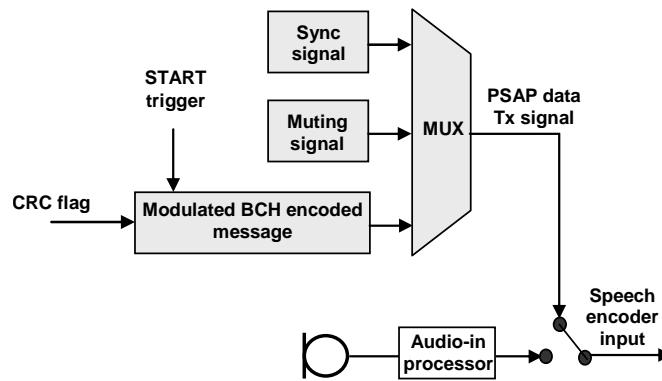

Figure 15: PSAP transmitter block diagram

6.1.1 Message encoding

The PSAP transmitter is designed to send up to 16 different link-layer feedback messages to the IVS. Three of them are used currently as follows:

- 1) START signal, i.e. the signal that triggers start of the IVS MSD transmission.
- 2) NACK, i.e. negative acknowledgement upon CRC check failure.
- 3) ACK, i.e. positive acknowledgement upon CRC check success.

A fourth link-layer message is defined for exclusive use in the compressed higher-layer ACK message (see Table 3).

6.1.2 BCH encoding

The link-layer feedback message code is error protected by a shortened (60, 4) BCH block code which is derived from a (63, 7) BCH code. The messages and their encoded representations are shown in Table 3.

Table 3: Downlink message encoding

Link-layer feedback message	Binary representation	BCH encoder output, b_i (hexadecimal)
START trigger	0000	A72 F298 41FA B376
CRC flag = 1 (ACK)	0001	4C4 1FD6 6ED2 7179
CRC flag = 0 (NACK)	0010	97A 8C41 FAB3 7693
reserved	0011	DBE 9397 9461 07EA
Not used	0100 to 1111	

The binary representations of the link-layer feedback messages defined in Table 3 are re-used for the compressed higher-layer ACK (HL-ACK) message, in which four data bits (i.e., two of the binary link-layer message representations) are transmitted in a different feedback message format (see clause 6.1.4)

6.1.3 Modulation

The encoded binary data stream bits b_i are grouped into symbols. Each symbol d_j carries 4 bits of information and modulates one basic downlink waveform.

The duration of the downlink waveform is 4 ms or 32 samples at 8 kHz sampling rate. Therefore 5 modulation frames correspond in length to one speech frame. Each modulated waveform carries one symbol of 4 bits of binary information and the modulation data rate is 1 000 bits/s for the downlink transmitter (modulation data rate for FEC-encoded bits, not considering muting gaps and synchronization frame).

The basic downlink waveform $p_{DL}(n)$ is defined for $n = 0, \dots, 31$ as follows:

$$p_{DL}(n) = (40, -200, 560, -991, -1400, 7636, 15000, 7636, -1400, -991, 560, -200, 40, 0)$$

Table 4 describes the symbol modulation mapping between symbol and the downlink waveform. The downlink waveform is derived from the basic downlink waveform $p_{DL}(n)$ by a cyclic right-shift by k samples, denoted by $(p \rightarrow k)$, and multiplication with a sign q .

Table 4: Symbol modulation mapping (downlink)

Symbol		Downlink waveform $w_{DL}(n) = q \cdot (p_{DL}(n) \rightarrow k)$ ($n=0,\dots,31$)	
d_j	b_i	sign q	cyclic shift k
0	0000	1	0
1	0001	1	4
2	0010	1	8
3	0011	1	12
4	0100	1	16
5	0101	1	20
6	0110	1	24
7	0111	1	28
8	1000	-1	28
9	1001	-1	24
10	1010	-1	20
11	1011	-1	16
12	1100	-1	12
13	1101	-1	8
14	1110	-1	4
15	1111	-1	0

Since there are only few messages for the downlink and the modulated waveform for each message is relatively short (480 samples), the modulated downlink waveforms are stored in ROM tables to save computation complexity at runtime. The downlink waveforms can be found in 3GPP TS 26.268 [2].

6.1.4 Downlink signal

6.1.4.1 Link-layer feedback messages

Every downlink message starts with a synchronization frame (as defined in clause 5.1.6) and continues with a feedback frame. For the link-layer control messages, the feedback frame consists of a single DL-Data field surrounded by muting periods as follows:

- 1) 2 frames of muting, M1 (40 ms).
- 2) 3 frames of modulated data, DL-Data (60 ms).
- 3) 2 frames of muting, M2 (40 ms).

Each DL-Data field includes one of the three types of link-layer messages in a block-encoded representation as described in clause 6.1.2.

6.1.4.2 Compressed higher-layer acknowledgement messages

For the compressed higher-layer acknowledgement messages, the synchronization frame defined in clause 5.1.6 is inverted (i.e., each sample is multiplied with -1). The feedback frame consists of two DL-Data fields preceded by a muting period as follows:

- 1) 1 frame of muting, M1 (20 ms).

- 2) 3 frames of modulated data, DL-Data 1 (60 ms).
- 3) 3 frames of modulated data, DL-Data 2 (60 ms).

Each DL-Data field includes one of the four types of block-encoded two-bit binary message representations as described in clause 6.1.2. The feedback frame for compressed higher-layer acknowledgement messages therefore transports four information bits for use by the higher-layer application protocol (HLAP). These information bits can be used to satisfy the eCall requirements [1], e.g. to clear down the call.

6.1.4.3 Handling of downlink messages

The PSAP transmitter retransmits the START message multiple times until it has detected the uplink synchronization frame. Upon detection of the synchronization frame, the PSAP transmitter sends a series of NACK messages, until a successful CRC check of the MSD message is obtained. After successful MSD detection, the PSAP transmitter sends link-layer ACK messages and then the compressed higher-layer ACK (HL-ACK). This operation is illustrated in Figure 16.

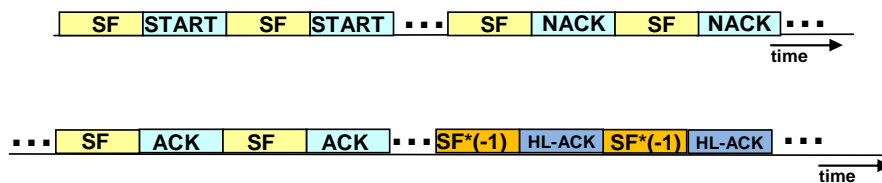

Figure 16: Downlink signal format

If the PSAP transmitter fails to obtain uplink synchronization, it will not start transmitting NACK on the downlink. Instead, START messages are repeated. The IVS awaits the reception of a NACK after transmission of the first uplink synchronization frame. If instead repeated START messages are received, it interrupts the current MSD transmission attempt and starts with a new synchronization frame and MSD $r=0$. If the receiver is not able to decode the message successfully within 8 redundancy versions, it asks the IVS to restart the transmission with a new synchronization frame and MSD $r=0$. This is achieved by switching from NACK to START messages.

The repetition of START messages by the PSAP (in case it does not obtain any uplink synchronization) continues until the PSAP modem is manually switched off by the operator. An automatic PSAP timeout mechanism should be added to the PSAP implementation if this behaviour is not desirable. The PSAP timeout mechanism is not part of this specification.

6.1.5 Synchronization

Synchronization signals for the PSAP transmitter are as described in clause 5.1.6, except that a value of 5000 is added to the PN sequence pulses (i.e., the resulting pulses have amplitudes of 25000 and -15000), and the original zeroes are replaced by samples with a value of 12000.

For compressed higher-layer acknowledgement messages, the synchronization frame defined above is inverted (i.e., each sample is multiplied with -1).

6.1.6 Multiplexing

The multiplexer combines synchronization, muting and feedback frames to form the downlink signal for the PSAP transmitter.

6.2 PSAP receiver

The PSAP receiver demodulates the MSD message from the IVS and checks the integrity of the received MSD by evaluating the CRC field. The different blocks of the PSAP receiver are shown in Figure 17.

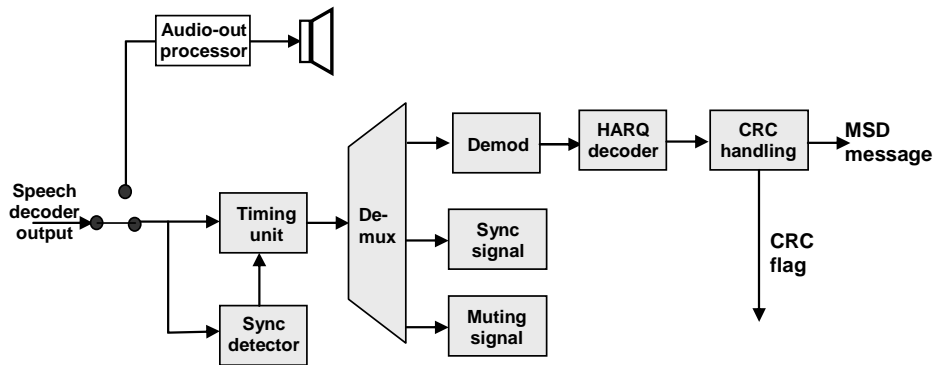

Figure 17: PSAP receiver block diagram

The PSAP receiver continuously monitors traffic from the speech decoder in idle or standby state. When the PSAP receiver is in idle state, speech from the speech decoder passes through as in normal voice call.

Once an eCall sync burst is detected, the PSAP transitions out of idle state and the speech path to audio out is muted.

6.2.1 Synchronization detector

Basically, the uplink synchronization detector works as described in clause 5.2.1. Some differences are given in the following.

The detection of a single synchronization preamble is sufficient to trigger the PSAP. A Sync Observer checks the received signal for another 10 speech frames after a preamble has been detected. This is to ensure that synchronization does not find a more reliable preamble, which would mean that the previous detection would have been a false detection (wrong delay value). In case synchronization does find a better preamble it restarts the reception of the MSD.

A tone detector based on a DFT evaluation at the two reference frequencies is used to evaluate the frequency of the sync tone. If the frequency can be detected reliably, then this decision is taken to decide on which modulator is used for demodulation. If a reliable detection is not possible, the fast modulation scheme is chosen if it is the first time that a preamble has been detected successfully while receiving the current MSD. Otherwise, the robust demodulator is chosen.

6.2.2 Timing Unit

As described in clause 5.2.2.

6.2.3 De-multiplexer

As described in clause 5.2.3.

6.2.4 Data demodulator

The data demodulator is represented by a correlator matched to the modulated waveform applied by the data modulator of the IVS transmitter. Specifically, correlations for all possible symbols are calculated:

$$r(i) = \sum_{j=0}^n ulPulse(j) * ulPulseMatch(i)(j)$$

$$r(i+4) = -r(3-i), \quad i = 0,1,2,3$$

where $n=15$ for the fast modulation mode and $n=31$ for the robust modulation mode.

The correlation values $r(i)$ are then normalized by their variance and subtracted by a mean value to be converted to soft symbols for the HARQ FEC decoder [2].

6.2.5 HARQ FEC decoder

The HARQ decoder combines the demodulated and deinterleaved data signal with previously transmitted redundancy versions. For this operation it applies a two stage rate matching scheme and performs turbo decoding of the combined soft-information.

To speed up the MSD reception in adverse transmission conditions, the HARQ decoding is performed for partially received messages, starting from the second redundancy version, $rv1$. Decoding is then attempted after reception of each of the three data parts of the MSD frame (see clause 5.1.5). The decoding attempts based on partial messages is beneficial since, in many cases, the correct MSD can be decoded already after the incremental redundancy contained in the first data part D1 of $rv1$. Figure 18 summarizes the decoder algorithm.

After MSD data bits are decoded, a descrambling operation as described in clause 5.1.2 applies.

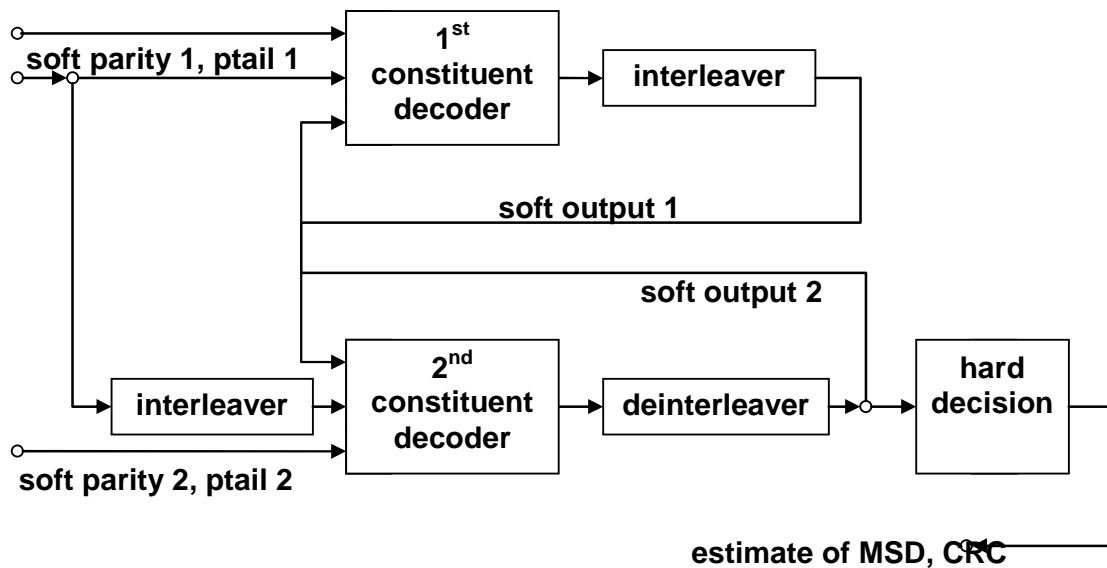

Figure 18: Turbo decoder

6.2.6 CRC handling

This function performs a CRC check and outputs a CRC flag. The CRC flag triggers transmission of an ACK or NACK message by the PSAP transmitter.

6.2.7 Push mode - push message detector

In *push* mode the PSAP receiver starts monitoring the incoming signal immediately after the call has been established. For the *push* message (IVS initiation sequence) detection, it applies the same receiver as described in clause 5.2. A *push* command is considered detected if two correct sync preambles have been detected and a subsequent *push* message (see Table 2b) has been identified.

7 Transmission protocol and error handling

This clause describes the employed eCall transmission protocol in normal operation, and its handling of transmission errors.

7.1 Normal operation

The operation of the eCall data transmission in the "normal" non-erroneous case works as outlined on a high level in the previous clauses.

Upon request by the operator or by the IVS *push* message, the PSAP transmitter starts sending START messages. The IVS receiver shall detect the synchronization preambles that are transmitted along with the START messages and obtain synchronization. This enables the IVS receiver to demodulate and detect the START messages. The PSAP transmitter continues sending START messages to the IVS at this stage.

Upon detection of the START message, the IVS starts the transmission of the first MSD message with incremental redundancy version *rv0* which is preceded by a synchronization frame. The PSAP receiver shall detect the synchronization frame and obtain exact synchronization on the synchronization preamble. The PSAP receiver is then enabled to demodulate the MSD and to decode it.

As soon as the PSAP receiver has obtained synchronization, it changes the PSAP to NACK message transmission and continues sending this message repeatedly. The IVS transmitter then should detect the NACK messages. The IVS continues sending MSD data. When transmission of the MSD message with *rv0* has been completed, the IVS transmitter continues sending the next redundancy version *rv1* of the same MSD, and so on.

The PSAP receiver, after demodulation of the full MSD with *rv0*, performs a CRC check. If the CRC check fails, the PSAP receiver continues sending NACK messages. If the CRC check succeeds, the PSAP transmitter changes the message to the link-layer ACK message. This ACK shall be transmitted consecutively at least four times for security. The IVS receiver should detect at least two of the ACK messages and then stop the IVS transmitter sending the MSD.

After transmitting all of the lower-layer ACK messages, the PSAP immediately sends the compressed higher-layer ACK message. This compressed higher-layer ACK message shall be transmitted consecutively at least five times for security. For a successful HL-ACK message reception, the IVS receiver should either detect three consecutive identical messages with inverted sync preamble (irrespective of correlation reliability threshold) or two reliable consecutive and identical messages.

7.2 Abnormal operation

This clause describes some abnormal scenarios which may occur due to severe signal distortion on the transmission channels and which need to be handled by the overall transmission protocol to avoid any deadlock situations. This description of abnormal scenarios is not necessarily exhaustive.

Table 5 lists potential abnormal scenarios together with the measures implemented against it in the eCall solution. In the table, the reference numbers refer to the following case categorization:

1. IVS error cases
 - 1.1 Sync error
 - 1.1.1 No successful synchronization
 - 1.1.2 Successful synchronization although no sync frames were sent
 - 1.1.3 Successful synchronization, but wrong timing
 - 1.1.4 Lost synchronization
 - 1.2 Sync detected, correct timing, false detection of PSAP messages
 - 1.2.1 Errors at transmission of START messages
 - 1.2.1.1 START message sent, no downlink message detected
 - 1.2.1.2 START message sent, NACK detected
 - 1.2.1.3 START message sent, ACK detected
 - 1.2.2 Errors at transmission of NACK messages
 - 1.2.2.1 NACK message sent, no downlink message detected
 - 1.2.2.2 NACK message sent, START detected
 - 1.2.2.3 NACK message sent, ACK detected

1.2.3 Errors at transmission of ACK messages

1.2.3.1 ACK message sent, no downlink message detected

1.2.3.2 ACK message sent, START detected

1.2.3.3 ACK message sent, NACK detected

2. PSAP error cases

2.1 Sync error

2.1.1 No sync preamble detected

2.1.2 Sync preamble detected, but wrong timing or false detection

2.1.3 False evaluation of sync tone

2.2 Sync detected, correct timing, false detection of MSD messages

Table 5: List of potential abnormal cases and protocol solutions

Ref #	Scenario	Error description	Error handling	Comments
1.1.1	IVS receiver does not detect the sync frames or gets different delays from subsequent preamble detections.	MSD message will never be sent	Start message is sent a defined number times	If the start message is not detected within a defined time, the PSAP goes back to idle state. In this case another attempt could be started manually by the PSAP operator.
1.1.2	IVS receiver detects equal sync frames while none were sent.	Sync false alarm	Sync Check verifies the validity of the sync continuously and resets the IVS if necessary.	Synchronization at the IVS has been designed such that the probability of this error is negligible small (virtually zero).
1.1.3	IVS receiver detects sync frames incorrectly and triggers nevertheless.	START message is usually not detected correctly and MSD message will never be sent	Same as #1.1.2	Same as #1.1.2
1.1.4	Synchronization gets lost due to some abnormal channel conditions	Feedback messages are skipped due to Sync Check	Same as #1.1.2	Could happen due to adaptive jitter buffers or in the unlikely case of a handover
1.2.1.1	In-sync, but detection of START messages fails	If START message is never detected, same as 1.1.1.	START message is repeated a defined number of times. This decreases the likelihood of this case to almost zero	
1.2.1.2	In-sync, instead of a START message a NACK is detected	MSD message is not sent if transmission has not yet started. If a transmission is ongoing, it will not be restarted although the PSAP would want the IVS to restart.	PSAP always transmits more than just one START message. A NACK before the first START message is ignored	

Ref #	Scenario	Error description	Error handling	Comments
1.2.1.3	In-sync, instead of a START message an ACK is detected	MSD message is not sent if transmission has not yet started. If a transmission is ongoing, the IVS could terminate the transmission erroneously	PSAP always transmits more than just one START message. An ACK before the first START message is ignored. If the transmission is terminated, the PSAP operator could retrigger the transmission of the MSD.	
1.2.2.1	In-sync, NACK message is not detected		NACK messages are repeated until the correct MSD is received	IVS behaviour does not change in this case
1.2.2.2	In-sync, instead of a NACK message a START message is detected	MSD transmission may be interrupted and restarted	Only after a successive reception of three START messages the MSD transmission is restarted	The probability of subsequent erroneously detected START messages is very low.
1.2.2.3	In-sync, instead of a NACK message an ACK is detected	IVS stops MSD transmission before PSAP has detected it.	At least two ACK messages need to be detected subsequently in order to stop transmission at the IVS. PSAP operator could retrigger the transmission of the MSD.	The probability of the subsequent erroneously detected ACK messages is very low.
1.2.3.1	In-sync, ACK message is not detected	Results in prolonged MSD transmission	ACK messages are sent several times	Not a problem as long as only few ACKs are missed.
1.2.3.2	In-sync, instead of a ACK message a START message is detected	Same as 1.2.2.2	Same as 1.2.2.2	
1.2.3.3	In-sync, instead of a ACK message a NACK is detected	Same as 1.2.3.1	Same as 1.2.3.1	Same as 1.2.3.1
2.1.1	No sync frame detection	PSAP misses the MSD	The PSAP continues sending START messages to the IVS until it detects a sync preamble. The IVS restarts transmission of the MSD with sync frame when it continuously receives START messages from the PSAP.	
2.1.2	PSAP receiver detects a sync frame while none was sent	Sync frame false alarm, PSAP tries to decode data, but fails.	After having failed the reception of the MSD, the PSAP will ask the IVS to resend the MSD by transmitting START messages again. The new MSD contains a new sync frame, which the PSAP uses to resynchronize.	Introduces a delay in MSD transmission

Ref #	Scenario	Error description	Error handling	Comments
2.1.3	Sync tone evaluated incorrectly	Wrong modulator mode used to demodulate the MSD	If there are doubts about the reliability of the tone detection, the PSAP uses the fast modulator mode for the first trial of demodulating the MSD (first set of 8 RVs) and the robust modulator mode otherwise.	This assumption about the modulator mode will be incorrect only if the IVS completely fails to evaluate many feedback messages, which is very unlikely.
2.2	Sync detected, correct timing, false positive detection of MSD messages	CRC gives incorrect result		Very unlikely

7.3 PSAP and IVS protocol state models

The state model of the PSAP is shown in Figure 19.

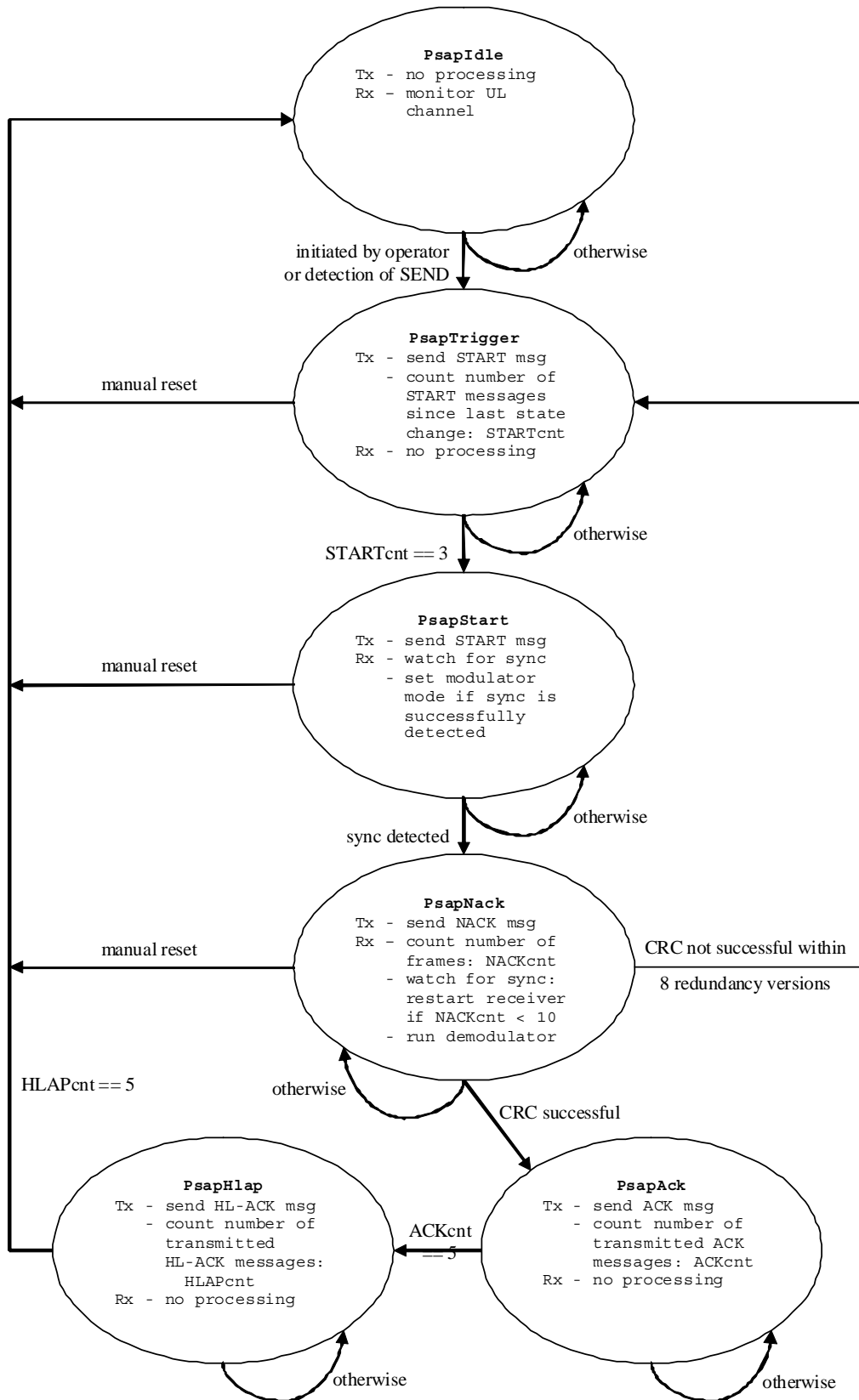

Figure 19: State model of the PSAP

The state model of the IVS is shown in Figure 20.

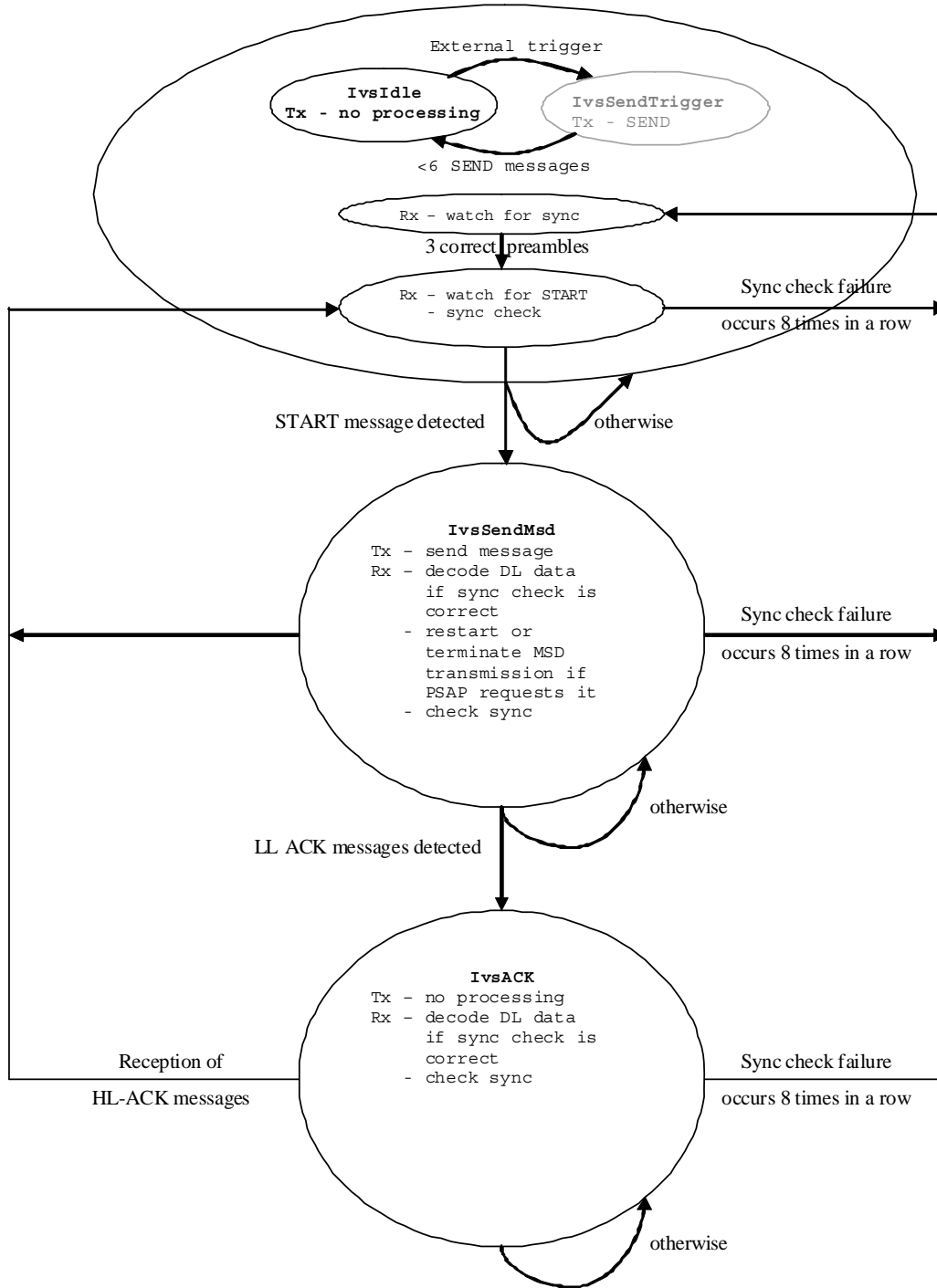

Figure 20: State model of the IVS

Annex A (informative): eCall Performance Requirements/Objectives and Design Constraints

Minimum performance requirements for non-bitexact implementations of the eCall modems, as well as exact performance figures of the bit-exact implementation, are given in a separate Conformance Testing document.

The following is reproduced for information from the permanent document "eCall Performance Requirements / Objectives and Design Constraints", for eCall Phase 2.

A.1 Definitions

Performance Requirements shall be met by an eCall candidate, otherwise it is excluded from the selection.

NOTE: The Performance Requirements include all service requirements.

Performance Objectives provide no hard limits, but allow ranking of candidates according to defined criteria.

Design Constraints provide upper limits (requirements and objectives), e.g. on algorithmic complexity.

Selection Checking of candidate solutions against the Performance Requirements and Design Constraints, and ranking of candidates based on Performance Objectives, after which the highest-ranked candidate is selected.

The **eCall Protocol** is the overall application-layer protocol between the IVS and PSAP. The selected candidate will provide data transport ("MODEM") for the eCall procedure. However, the application-layer of the eCall procedure is out of the scope.

A.2 Performance Requirements

The following text defines point by point the (Service) Performance Requirements for an eCall candidate. They have been taken directly from 3GPP TS 22.101 [1].

NOTE 1: 3GPP TS 22.101 [1] has been modified in the meantime to version V8.8.0. The changes introduced have been evaluated. They have no influence on the selection phase for eCall.

NOTE 2: For the sake of the selection procedure, the candidate shall provide means for automatic retransmission. This is however not necessarily the final eCall Protocol.

1. The data may be sent prior to, in parallel with, or at the start of the voice component of an emergency call.

NOTE 3: In-band data can not be sent prior to the point in time when the voice channel is established end-to-end.

This requirement does not require additional interpretation.

2. Should the PSAP request additional data then this may be possible during the established emergency call.

This service requirement is considered in the selection as follows:

"The eCall candidate algorithm shall allow the PSAP to request additional data at any time during the established emergency call."

3. The realisation of the transfer of data during an emergency call shall minimise changes to the originating and transit networks.

This service requirement is considered in the selection as follows: "The introduction of the eCall data transfer feature should have minimal (ideally no) impact on any existing mobile and transit network (in Europe), i.e. it should not require (major) changes nor impose (major) restrictions to future evolutions of the networks."

4. Both the voice and data components of the emergency call shall be routed to the same PSAP or designated emergency call centre.

NOTE 4: In-band data can not be routed somewhere other than the voice channel it uses.

This service requirement does not need to be considered in the selection.

5. The transmission of the data shall be acknowledged and if necessary data shall be retransmitted.
This service requirement is considered in the selection as follows: "In the case of errors detected by the candidate algorithm in the received data, a retransmission shall be requested by the candidate algorithm."
6. A UE configured only to transfer data during emergency calls (e.g. eCall only UE) shall not generate signalling to the network besides what is needed to place an emergency call.
This service requirement does not need to be considered in the selection.
7. With the exception of the following specific requirements, considered necessary for the satisfactory operation of the eCall service, all existing TS12 emergency call requirements shall apply.
This service requirement does not need to be considered in the selection.
8. An eCall shall consist of a TS12 emergency call supplemented by a minimum set of emergency related data (MSD).
This service requirement does not need to be considered in the selection.
9. An eCall may be initiated automatically, for example due to a vehicle collision, or manually by the vehicle occupants.
This service requirement does not need to be considered in the selection.
10. The Minimum Set of Data (MSD) sent by the In vehicle System (IVS) to the network shall not exceed 140 bytes.
This service requirement is considered in the selection as follows: "The whole 140 Bytes of the MSD shall be made available to the PSAP."
11. The MSD should typically be made available to the PSAP within 4 seconds, measured from the time when end to end connection with the PSAP is established.
This service requirement is considered in the selection as follows: "In optimal conditions (error-free radio channel, GSM FR codec and FR AMR 12.2 kbit/s mode) the eCall candidate procedure shall be able to transmit the whole 140 bytes of the MSD reliably within 4 seconds, measured from the time when the transmission from the IVS to the PSAP begins (after a trigger from the PSAP has been detected)."

NOTE 5: See Performance Requirement 14.

NOTE 6: "Reliability" is defined in the new Performance Requirement 15.

NOTE 7: The Performance Objectives give additional guidelines for the performance under non-ideal channel conditions.

12. Should the MSD component not be included in an eCall, or is corrupted or lost for any reason, then this shall not affect the associated TS12 emergency call speech functionality.
This service requirement does not need to be considered in the selection.

13. A call progress indication shall be provided to the user whilst the MSD transmission is in progress
This service requirement does not need to be considered in the selection.

In addition to the above Service Requirements, the following Performance Requirement shall apply to an eCall candidate solution.

14. Installation of eCall equipment in a vehicle shall not affect an emergency call to a PSAP which is not upgraded to receive eCall data, i.e. the eCall candidate algorithm shall not send the eCall data unless the PSAP requests that it do so.
15. The MSD shall be transmitted reliably to the PSAP. An MSD transmission is considered reliably terminated, if a cyclic redundancy check (CRC) of at least 28 bits, applied to the entire MSD, detects no errors.

NOTE 8: If the CRC detects an error in the MSD, then an automatic retransmission shall be triggered, unless the PSAP decides to stop the transmission.

A.3 Performance Objectives

Performance Objective 1: The overall average transmission time should be as small as possible.

Performance Objective 2: Under all test conditions, a candidate should be as good as or better than the proposed eCall_via_CTM* (see 3GPP TR 26.967 [4]) would be.

NOTE: The objectives in the present document are intended as guidelines for designers of eCall solution candidates. The exact rules of candidate selection are specified in a separate document (PD3, "eCall Selection Test"). Objective 1 will be considered in the formulation of these rules. Objective 2 is intended only as a guideline and will not be considered in the formulation of the selection rules.

Performance Objective 1 is explained in detail in the following:

For any particular test condition (specified by speech codec plus radio channel error condition), the observed transmission time of the 140 bytes of the MSD may vary depending on the parameters of the channel simulation and the specific contents of the MSD. Therefore each MSD transmission may be regarded as one trial k in a random experiment, where the observed transmission time, T_k , is the random variable of interest. For each particular test condition C , the MSD transmission is repeated with different, randomly generated MSD data for at least 100 times ($k = 1, 2, \dots, n$, where $n \geq 100$) to get enough statistical significance.

To ensure a practical limit on the time required for testing a candidate, the observed value of T_k must have a reasonable upper bound. This upper bound, t_{UB} , is fixed at a value of 200 seconds for one trial for all test conditions. Any value of T_k that is observed to be greater than t_{UB} will be classified as a transmission failure and will be assigned the value of t_{UB} .

Each particular test condition C gives an observed sample distribution T_1, T_2, \dots, T_n . The statistic of interest is the average value, $\mu_C = (T_1 + T_2 + \dots + T_n) / n$.

The Figure of Merit (FoM) over *all* test conditions is calculated by unweighted averaging of μ_C over all particular test conditions C_1, C_2, \dots, C_m . A low Figure of Merit is – obviously - better than a higher Figure of Merit. The candidates will be ranked by their Figures of Merit.

The following assumptions are made for the measurement of T_k .

1. The starting time of the transmission with respect to speech codec audio frames is uniformly distributed.
2. The channel error condition is modelled by an error pattern obtained from offline simulations. The following radio conditions will be tested:
 - GMSK Full Rate radio channel at C/I values of 1, 4, 7, 10, 13, 16 dB, and error free; with ideal frequency hopping, with the Typical Urban profile and with slow vehicle speed. These channel conditions will be applied in both directions (uplink and downlink) symmetrically.
 - GMSK Full Rate radio channel at RSSI value -100 dBm with no other interferer. This channel condition will be applied in both directions (uplink and downlink) symmetrically.

The following speech Codecs will be tested: GSM_FR and FR_AMR (12.2, 10.2, 7.95, 7.4, 6.7, 5.9, 5.15, 4.75 kbps). DTX will be enabled in both directions.

Table A.1 gives an allocation of Codec Conditions to radio conditions in order to reduce the test effort to the reasonable minimum. The detailed allocation is defined in PD3, the "Selection Test Plan" Permanent Document.

Table A.1

	GSM_FR	12.2	10.2	7.95	7.4	6.7	5.9	5.15	4.75
C/I = 1 dB									X
C/I = 4 dB							X	X	X
C/I = 7 dB	X	X	X	X	X	X	X	X	X
C/I = 10 dB	X	X	X	X	X				
C/I = 13 dB	X	X	X						
C/I = 16 dB	X								
error free	X	X							
RSSI = -100 dBm	X								X

3. It is assumed that the transmission in the wireline part of the eCall uses PCM (G.711, A-law) without any further transcoding and with a fixed, pre-selected level setting.
4. It is assumed that no acoustical echo is produced by the IVS and that therefore no Acoustic Echo Suppressor is applied in the network.
5. It is assumed that no Hybrid Echo is produced by the PSAP connection and that therefore no Hybrid Echo canceller is applied in the network.
6. The MSD will contain randomly generated data. (Each possible byte sequence is considered to be equally probable.)
7. The round-trip delay between the IVS and PSAP is a randomly generated value in the range (200 ms, 220 ms).

A.4 Design Constraints

- The candidate algorithm as implemented in the IVS should not have more than 10 times the complexity of CTM. The candidate algorithm as implemented in the PSAP should not have more than 20 times the complexity of CTM. The complexity is estimated by compiling the C-Codes under similar compiler conditions and then measuring the processing times.
- The candidate algorithm as implemented in the IVS should not require more than 20KB of data memory. The candidate algorithm as implemented in the PSAP should not require more than 40KB of data memory. The memory requirements are estimated by inspection of the C-Codes.
- The IVS modem shall not be dependent on knowledge of the UE (e.g. the speech codec being used and the radio channel conditions).
- The IVS modem shall not require changes in the UE.
- The PSAP Modem shall not be dependent on knowledge of the call path (e.g. the speech codec being used and the radio channel conditions, delay, transcoding, etc.).

Annex B (informative): Change history

Change history							
Date	TSG SA#	TSG Doc.	CR	Rev	Subject/Comment	Old	New
2009-03	43	SP-090008			Approved at TGS SA#43	2.0.0	8.0.0
2009-06	44	SP-090251	0001	1	Correction of the required number of transmitted ACK messages	8.0.0	8.1.0
2009-09	45	SP-090565	0002	1	Integration of higher-layer acknowledgement message	8.1.0	8.2.0
2009-09	45	SP-090576	0003	1	Integration of IVS-initiated signalling option	8.1.0	8.2.0
2009-09	45	SP-090624	0004	3	IVS transmitter termination correction	8.1.0	8.2.0
2009-12	46	SP-090702	0005	1	Correction to text in clause 4.3	8.2.0	8.3.0
2009-12	46				Version for Release 9	8.3.0	9.0.0
2010-06	48	SP-100297	0007		Detector for handling PCM sample inversion in the network	9.0.0	9.1.0
2010-06	48	SP-100297	0009		Feedback signal modifications to increase robustness in the presence of network echo cancellers	9.0.0	9.1.0

History

Document history		
V9.0.0	January 2010	Publication
V9.1.0	June 2010	Publication