

ETSI TS 129 118 V9.6.0 (2012-01)



**Universal Mobile Telecommunications System (UMTS);
LTE;
Mobility Management Entity (MME)
- Visitor Location Register (VLR)
SGs interface specification
(3GPP TS 29.118 version 9.6.0 Release 9)**



Reference

RTS/TSGC-0129118v960

Keywords

LTE,UMTS

ETSI

650 Route des Lucioles
F-06921 Sophia Antipolis Cedex - FRANCE

Tel.: +33 4 92 94 42 00 Fax: +33 4 93 65 47 16

Siret N° 348 623 562 00017 - NAF 742 C
Association à but non lucratif enregistrée à la
Sous-Préfecture de Grasse (06) N° 7803/88

Important notice

Individual copies of the present document can be downloaded from:

<http://www.etsi.org>

The present document may be made available in more than one electronic version or in print. In any case of existing or perceived difference in contents between such versions, the reference version is the Portable Document Format (PDF). In case of dispute, the reference shall be the printing on ETSI printers of the PDF version kept on a specific network drive within ETSI Secretariat.

Users of the present document should be aware that the document may be subject to revision or change of status. Information on the current status of this and other ETSI documents is available at

<http://portal.etsi.org/tb/status/status.asp>

If you find errors in the present document, please send your comment to one of the following services:

http://portal.etsi.org/chaicor/ETSI_support.asp

Copyright Notification

No part may be reproduced except as authorized by written permission.
The copyright and the foregoing restriction extend to reproduction in all media.

© European Telecommunications Standards Institute 2012.
All rights reserved.

DECT[™], **PLUGTESTS**[™], **UMTS**[™] and the ETSI logo are Trade Marks of ETSI registered for the benefit of its Members.
3GPP[™] and **LTE**[™] are Trade Marks of ETSI registered for the benefit of its Members and
of the 3GPP Organizational Partners.
GSM[®] and the GSM logo are Trade Marks registered and owned by the GSM Association.

Intellectual Property Rights

IPRs essential or potentially essential to the present document may have been declared to ETSI. The information pertaining to these essential IPRs, if any, is publicly available for **ETSI members and non-members**, and can be found in ETSI SR 000 314: *"Intellectual Property Rights (IPRs); Essential, or potentially Essential, IPRs notified to ETSI in respect of ETSI standards"*, which is available from the ETSI Secretariat. Latest updates are available on the ETSI Web server (<http://ipr.etsi.org>).

Pursuant to the ETSI IPR Policy, no investigation, including IPR searches, has been carried out by ETSI. No guarantee can be given as to the existence of other IPRs not referenced in ETSI SR 000 314 (or the updates on the ETSI Web server) which are, or may be, or may become, essential to the present document.

Foreword

This Technical Specification (TS) has been produced by ETSI 3rd Generation Partnership Project (3GPP).

The present document may refer to technical specifications or reports using their 3GPP identities, UMTS identities or GSM identities. These should be interpreted as being references to the corresponding ETSI deliverables.

The cross reference between GSM, UMTS, 3GPP and ETSI identities can be found under <http://webapp.etsi.org/key/queryform.asp>.

Contents

Intellectual Property Rights	2
Foreword.....	2
Foreword.....	7
1 Scope	8
2 References	8
3 Definitions and abbreviations.....	9
3.1 Definitions	9
3.2 Abbreviations	9
4 Description of the SGs association between a VLR and an MME.....	10
4.1 General	10
4.2 SGs association at the VLR.....	10
4.2.1 General.....	10
4.2.2 States at the VLR.....	10
4.3 SGs association at the MME	11
4.3.1 General.....	11
4.3.2 MM context variables at the MME.....	11
4.3.3 States at the MME	11
5 Procedures for SGs.....	12
5.1 Paging for non-EPS services procedure	12
5.1.1 General description	12
5.1.2 Procedures in the VLR.....	12
5.1.2.1 General	12
5.1.2.2 Paging Initiation.....	13
5.1.2.3 Paging Response	13
5.1.2.4 Paging Failure	13
5.1.2.5 UE unreachable	14
5.1.3 Procedures in the MME	14
5.1.3.1 General	14
5.1.3.2 Procedure when no NAS signalling connection exists.....	15
5.1.3.3 Procedure when a NAS signalling connection exists	16
5.2 Location update for non-EPS services procedure.....	16
5.2.1 General description	16
5.2.2 Procedures in the MME	16
5.2.2.1 General	16
5.2.2.2 Location update initiation	16
5.2.2.3 Location update response.....	18
5.2.2.4 Location update failure	18
5.2.2.5 Abnormal cases	18
5.2.3 Procedures in the VLR.....	19
5.2.3.1 General	19
5.2.3.2 Location update response.....	19
5.2.3.3 Location update failure	19
5.2.3.4 TMSI reallocation procedure	19
5.2.3.5 Abnormal cases	19
5.3 Non-EPS alert procedure.....	20
5.3.1 General description	20
5.3.2 Procedures in the VLR.....	20
5.3.2.1 Alert Initiation.....	20
5.3.2.2 Alert Response	20
5.3.2.3 Alert Failure	21
5.3.2.4 Alert Indication	21
5.3.2.5 Abnormal cases	21
5.3.3 Procedures in the MME	21

5.3.3.1	Alert response	21
5.3.3.2	Alert failure	21
5.3.3.3	Alert indication	21
5.4	Explicit IMSI detach from EPS services	21
5.4.1	General description	21
5.4.2	Procedures in the MME	22
5.4.2.1	Explicit EPS detach indication	22
5.4.2.2	Explicit EPS detach response	22
5.4.2.3	Abnormal cases	22
5.4.3	Procedures in the VLR	22
5.5	Explicit IMSI detach from non-EPS services	23
5.5.1	General description	23
5.5.2	Procedures in the MME	23
5.5.2.1	Explicit IMSI detach initiation	23
5.5.2.2	Explicit IMSI detach response	23
5.5.2.3	Abnormal cases	23
5.5.3	Procedures in the VLR	24
5.6	Implicit IMSI detach from non-EPS services	24
5.6.1	General description	24
5.6.2	Procedures in the MME	24
5.6.3	Procedures in the VLR	24
5.7	VLR failure procedure	24
5.7.1	General description	24
5.7.2	Procedures in the VLR	25
5.7.2.1	VLR Reset Initiation	25
5.7.2.2	VLR Reset Response	25
5.7.2.3	Abnormal cases	25
5.7.3	Procedures in the MME	25
5.8	MME failure procedure	25
5.8.1	General description	25
5.8.2	Procedures in the MME	25
5.8.2.1	MME Reset Initiation	25
5.8.2.2	MME Reset Response	26
5.8.2.3	Abnormal cases	26
5.8.3	Procedures in the VLR	26
5.9	HSS failure	26
5.9.1	General description	26
5.9.2	Procedures in the MME	27
5.10	MM information procedure	27
5.10.1	General description	27
5.10.2	Procedures in the VLR	27
5.10.3	Procedures in the MME	27
5.11	Procedure for tunnelling of NAS messages	27
5.11.1	General description	27
5.11.2	Uplink unitdata procedure	27
5.11.2.1	Procedures in the MME	27
5.11.2.2	Procedures in the VLR	28
5.11.2.3	Abnormal cases	28
5.11.3	Downlink unitdata procedure	28
5.11.3.1	Procedures in the VLR	28
5.11.3.2	Procedures in the MME	28
5.11.3.3	Abnormal cases	28
5.11.4	Release procedure	28
5.12	Service request procedure	29
5.12.1	General description	29
5.12.2	Procedures in the MME	29
5.12.3	Procedures in the VLR	29
6	SGs transport	29
6.1	General	29
6.2	IP layer	29
6.3	Transport layer	30

7	Error handling	30
7.1	General	30
7.2	Message too short.....	30
7.3	Unknown or unforeseen message type	31
7.4	Missing mandatory information element.....	31
7.5	Information elements unknown or unforeseen in the message	31
7.6	Out of sequence information elements	31
7.7	Repeated information elements	31
7.8	Syntactically incorrect mandatory information element.....	31
7.9	Syntactically incorrect optional information elements	31
7.10	Conditional information element errors	32
7.11	Information elements with semantically incorrect contents	32
8	Message functional definitions and contents.....	32
8.1	SGsAP-ALERT-ACK message.....	32
8.2	SGsAP-ALERT-REJECT message	32
8.3	SGsAP-ALERT-REQUEST message	33
8.4	SGsAP-DOWNLINK-UNITDATA message.....	33
8.5	SGsAP-EPS-DETACH-ACK message	33
8.6	SGsAP-EPS-DETACH-INDICATION message	33
8.7	SGsAP-IMSI-DETACH-ACK message.....	34
8.8	SGsAP-IMSI-DETACH-INDICATION message.....	34
8.9	SGsAP-LOCATION-UPDATE-ACCEPT message	34
8.9.1	Message definition.....	34
8.9.2	New TMSI, or IMSI.....	35
8.10	SGsAP-LOCATION-UPDATE-REJECT message.....	35
8.11	SGsAP-LOCATION-UPDATE-REQUEST message.....	36
8.11.1	Message definition.....	36
8.11.2	Old location area identifier	36
8.11.3	TMSI status.....	36
8.11.4	IMEISV	36
8.11.5	TAI.....	36
8.11.6	E-CGI.....	36
8.12	SGsAP-MM-INFORMATION-REQUEST	36
8.13	SGsAP-PAGING-REJECT message.....	37
8.14	SGsAP-PAGING-REQUEST message.....	37
8.14.1	Message definition.....	37
8.14.2	TMSI.....	38
8.14.3	CLI.....	38
8.14.4	Location area identifier	38
8.14.5	Global CN-Id	38
8.14.6	SS code	38
8.14.7	LCS indicator.....	38
8.14.8	LCS client identity.....	39
8.14.9	Channel needed.....	39
8.14.10	eMLPP priority	39
8.15	SGsAP-RESET-ACK message	39
8.15.1	Message definition.....	39
8.15.2	MME name	39
8.15.3	VLR name.....	39
8.16	SGsAP-RESET-INDICATION message	39
8.16.1	Message definition.....	39
8.16.2	MME name	40
8.16.3	VLR name.....	40
8.17	SGsAP-SERVICE-REQUEST message.....	40
8.17.1	Message definition.....	40
8.17.2	IMEISV	41
8.17.3	UE Time Zone	41
8.17.4	Mobile Station Classmark 2.....	41
8.17.5	TAI.....	41
8.17.6	E-CGI.....	41
8.17.7	UE EMM Mode	41

8.18	SGsAP-STATUS message	41
8.18.1	Message definition	41
8.18.2	IMSI	41
8.19	SGsAP-TMSI-REALLOCATION-COMplete message	41
8.20	SGsAP-UE-ACTIVITY-INDICATION message	42
8.21	SGsAP-UE-UNREACHABLE message	42
8.22	SGsAP-UPLINK-UNITDATA message	42
8.22.1	Message definition	42
8.22.2	IMEISV	43
8.22.3	UE Time Zone	43
8.22.4	Mobile Station Classmark 2	43
8.22.5	TAI	43
8.22.6	E-CGI	43
8.23	SGsAP-RELEASE-REQUEST message	43
9	Information element coding	44
9.1	Overview	44
9.2	Message type	44
9.3	Information element identifiers	45
9.4	Information elements	45
9.4.1	CLI	45
9.4.2	EPS location update type	45
9.4.3	Erroneous message	46
9.4.3a	E-UTRAN Cell Global Identity	46
9.4.4	Global CN-Id	46
9.4.5	IMEISV	46
9.4.6	IMSI	46
9.4.7	IMSI detach from EPS service type	47
9.4.8	IMSI detach from non-EPS service type	47
9.4.9	LCS client identity	48
9.4.10	LCS indicator	48
9.4.11	Location area identifier	48
9.4.12	MM information	49
9.4.13	MME name	49
9.4.14	Mobile identity	49
9.4.14a	Mobile Station Classmark 2	49
9.4.15	NAS message container	49
9.4.16	Reject cause	49
9.4.17	Service indicator	49
9.4.18	SGs cause	50
9.4.19	SS code	51
9.4.20	TMSI	51
9.4.21	TMSI status	51
9.4.21a	Tracking Area Identity	51
9.4.21b	UE Time Zone	51
9.4.21c	UE EMM mode	51
9.4.22	VLR name	52
9.4.23	Channel needed	52
9.4.24	eMLPP priority	52
10	List of system variables	53
10.1	Timers	53
10.2	Retry counters	54
Annex A (informative): Change history		55
History		57

Foreword

This Technical Specification has been produced by the 3rd Generation Partnership Project (3GPP).

The contents of the present document are subject to continuing work within the TSG and may change following formal TSG approval. Should the TSG modify the contents of the present document, it will be re-released by the TSG with an identifying change of release date and an increase in version number as follows:

Version x.y.z

where:

- x the first digit:
 - 1 presented to TSG for information;
 - 2 presented to TSG for approval;
 - 3 or greater indicates TSG approved document under change control.
- y the second digit is incremented for all changes of substance, i.e. technical enhancements, corrections, updates, etc.
- z the third digit is incremented when editorial only changes have been incorporated in the document.

1 Scope

CS Fallback in the Evolved Packet System (EPS) enables the provisioning of CS-domain services (e.g. voice call, Location Services (LCS) or supplementary services) by reuse of CS infrastructure when the UE is served by E-UTRAN. Additionally, SMS delivery via the CS core network is realized without CS fallback.

The present document specifies the procedures and the SGs Application Part (SGsAP) messages used on the SGs interface between the Mobility Management Entity (MME) in the EPS and the Visitor Location Register (VLR), to allow location management coordination and to relay certain messages related to GSM circuit switched services over the EPS system.

The present document also specifies the use of Stream Control Transmission Protocol (SCTP) for the transport of SGsAP messages.

The present document is applicable to the MME in the EPS and to the VLR. The functional split between the MME and the VLR is defined in 3GPP TS 23.272 [7].

2 References

The following documents contain provisions which, through reference in this text, constitute provisions of the present document.

- References are either specific (identified by date of publication, edition number, version number, etc.) or non-specific.
- For a specific reference, subsequent revisions do not apply.
- For a non-specific reference, the latest version applies. In the case of a reference to a 3GPP document (including a GSM document), a non-specific reference implicitly refers to the latest version of that document *in the same Release as the present document*.

- [1] 3GPP TR 21.905: "Vocabulary for 3GPP Specifications".
- [2] 3GPP TS 22.101: "Service aspects; Service principles".
- [3] 3GPP TS 23.003: "Numbering, addressing and identification".
- [4] 3GPP TS 23.007: "Restoration procedures".
- [5] 3GPP TS 23.018: "Basic call handling; Technical realization".
- [5AA] 3GPP TS 23.078: "Customised Applications for Mobile network Enhanced Logic (CAMEL) Phase 4; Stage 2".
- [5A] 3GPP TS 23.081: "Line identification supplementary services".
- [5B] 3GPP TS 23.082: "Call Forwarding (CF) supplementary services".
- [6] Void.
- [6A] 3GPP TS 23.236: "Intra-domain connection of Radio Access Network (RAN) nodes to multiple Core Network (CN) nodes".
- [7] 3GPP TS 23.272: "Circuit Switched Fallback in Evolved Packet System; Stage 2".
- [8] 3GPP TS 24.008: "Mobile radio interface Layer 3 specification; Core network protocols; Stage 3".
- [9] 3GPP TS 24.010: "Supplementary services specification; General aspects".
- [10] 3GPP TS 24.011: "Point-to-Point (PP) Short Message Service (SMS) support on mobile radio interface".

- [11] 3GPP TS 24.030: "Location Services (LCS); Supplementary service operations; Stage 3".
- [12] 3GPP TS 24.081: "Line Identification Supplementary Services - Stage 3".
- [13] 3GPP TS 24.082: "Call Forwarding (CF) supplementary services; Stage 3".
- [14] 3GPP TS 24.301: "Non-Access-Stratum (NAS) protocol for Evolved Packet System (EPS); Stage 3".
- [15] 3GPP TS 29.002: "Mobile Application Part (MAP) specification".
- [15A] 3GPP TS 29.011: "Signalling interworking for supplementary services".
- [16] 3GPP TS 29.018: "Serving GPRS Support Node (SGSN) - Visitors Location Register (VLR) Gs interface layer 3 specification".
- [17] 3GPP TS 29.272: "MME and SGSN Related Interfaces Based on Diameter Protocol".
- [17A] 3GPP TS 29.274: "3GPP Evolved Packet System (EPS); Evolved General Packet Radio Service (GPRS) Tunnelling Protocol for Control plane (GTPv2-C); Stage 3".
- [17B] 3GPP TS 32.250: "Telecommunication management; Charging management; Circuit Switched (CS) domain charging".
- [18] 3GPP TS 32.422: "Telecommunication management; Subscriber and equipment trace; Trace control and configuration management (CM)".
- [19] 3GPP TS 36.331: "Evolved Universal Terrestrial Radio Access (E-UTRA); Radio Resource Control (RRC) protocol specification".
- [20] IETF RFC 791 (September 1981): "Internet Protocol".
- [21] IETF RFC 1035 (November 1987): "Domain Names - Implementation and Specification".
- [22] IETF RFC 2460 (December 1998): "Internet Protocol, Version 6 (IPv6) Specification".
- [23] IETF RFC 4960 (September 2007): "Stream Control Transmission Protocol".

3 Definitions and abbreviations

3.1 Definitions

For the purposes of the present document, the terms and definitions given in 3GPP TR 21.905 [1] apply. Additionally the following definitions of 3GPP TS 24.301 [14] apply:

Non-EPS services

SMS only

SMS over SGs

3.2 Abbreviations

For the purposes of the present document, the abbreviations given in 3GPP TR 21.905 [1] and the following apply. An abbreviation defined in the present document takes precedence over the definition of the same abbreviation, if any, in 3GPP TR 21.905 [1].

LCS	Location Services
MME	Mobility Management Entity
NEAF	Non-EPS Alert Flag
SCTP	Stream Control Transmission Protocol
SGsAP	SGs Application Part

SMS Short Message Service
PSI Provide Subscriber Information

4 Description of the SGs association between a VLR and an MME

4.1 General

CS fallback function and SMS delivery via the CS core network is realized by reusing Gs interface mechanisms as defined in 3GPP TS 29.018 [16] on the interface between the MME in the EPS and the VLR. This interface is called SGs interface.

NOTE: Within this specification, the term VLR refers to MSC/VLR or MSC Server/VLR.

The SGs interface connects the databases in the VLR and the MME. The procedures described in the present document are used to co-ordinate the location information of UEs that are IMSI attached to both EPS and non-EPS services. The SGs interface is also used to convey some circuit switched related procedures via the MME.

The basis for the interworking between a VLR and an MME is the existence of a SGs association between those entities per UE. The SGs association is applicable to UEs which are configured to use CS fallback and SMS over SGs, or SMS over SGs only.

The behaviour of the VLR and the MME entities related to the SGs interface are defined by the state of the SGs association for a UE. Individual states per SGs association, i.e. per UE are held at both the VLR and the MME.

4.2 SGs association at the VLR

4.2.1 General

The states associated to the SGs interface in the VLR are specified in subclause 4.2.2 and the state diagram at the VLR is shown in figure 4.2.2.1. The state diagram does not include the message error handling specified in clause 7.

4.2.2 States at the VLR

SGs-NULL

There is no SGs association with an MME for the UE and therefore the VLR considers that the UE is IMSI detached for EPS services. In this state no SGsAP-MM-INFORMATION-REQUEST messages are sent to the MME. The VLR may initiate paging on the SGs interface if the "Confirmed by Radio Contact" restoration indicator in the VLR is set to "false" (see 3GPP TS 23.007 [4]). Any message from the MME is ignored except SGsAP-LOCATION-UPDATE-REQUEST and SGsAP-IMSI-DETACH-INDICATION.

LA-UPDATE-PRESENT

The VLR has received an SGsAP-LOCATION-UPDATE-REQUEST message from the MME. In this state, the VLR may be waiting for the outcome of the Update Location procedure from the HSS, if the IMSI is not known in the VLR. For UEs which are configured to use CS fallback and SMS over SGs, or SMS over SGs only, the VLR shall send SGsAP-PAGING-REQUEST messages only via the SGs interface.

SGs-ASSOCIATED

The VLR considers that the UE is attached to both EPS and non-EPS services. For UEs which are configured to use CS fallback and SMS over SGs, or SMS over SGs only, the VLR sends SGsAP-PAGING-REQUEST messages only via the SGs interface. The VLR can perform the MM information procedure.

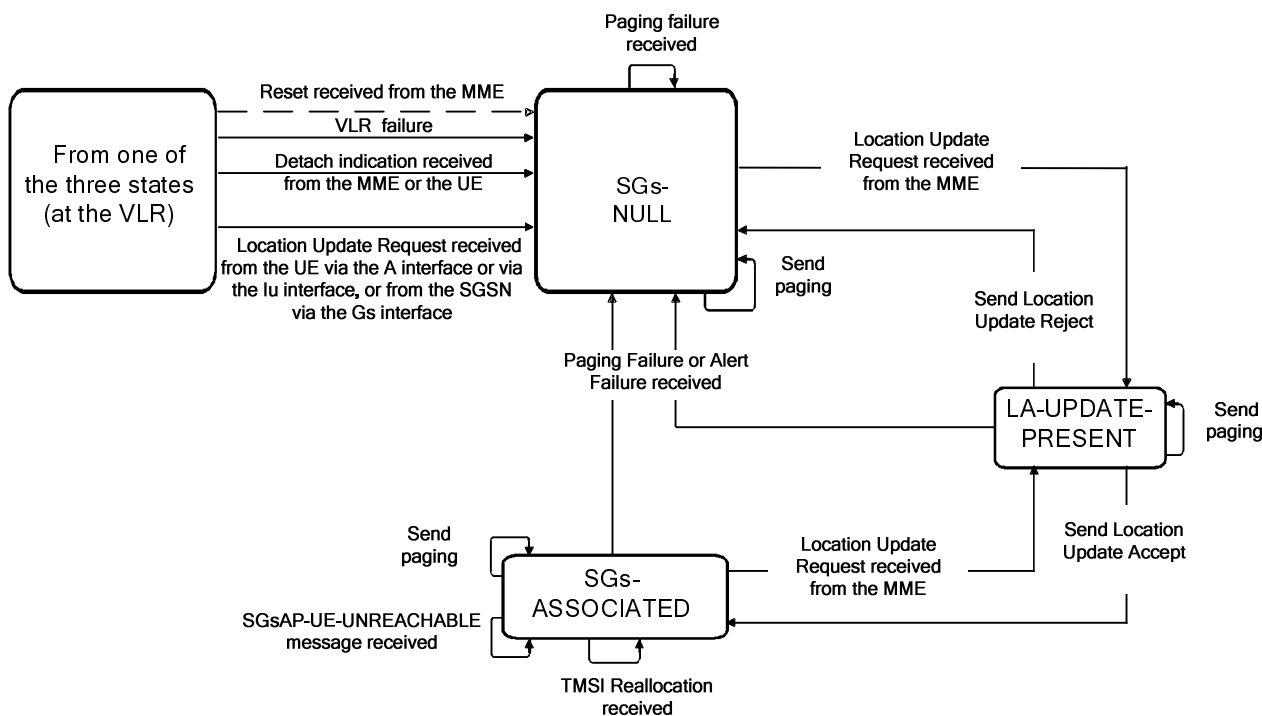

NOTE: Receipt of an SGsAP-RESET-INDICATION message from the MME may change or not the state of the SGs interface of all the associations associated to the restarted MME, see subclause 5.8.3.

Figure 4.2.2.1: State diagram at the VLR

4.3 SGs association at the MME

4.3.1 General

The MM context variables associated to the SGs interface in the MME are specified in subclause 4.3.2 and states associated to the SGs interface in the MME are specified in subclause 4.3.3. The state diagram at the MME is shown in figure 4.3.3.1. The state diagram does not include the message error handling specified in clause 7.

4.3.2 MM context variables at the MME

VLR-Reliable:

Boolean set to "false" when the MME has received a reset indication from the VLR. The MME may request the UE, upon reception of the next tracking area update (periodic or combined) procedure, to re-attach to non-EPS services if the UE is still IMSI attached to non-EPS services. Alternatively, the MME may, upon reception of a periodic or combined tracking area update request from a UE that is still attached for non-EPS services, perform immediately the location update for non-EPS services procedure.

MME-Reset:

Boolean set to "true" when the MME restarts after a failure. The "MME-Reset" restoration indicator is unique within an MME and it applies to all the MM contexts stored in the MME.

4.3.3 States at the MME

SGs-NULL

There is no SGs association with a VLR for the UE and therefore the MME considers that the UE is IMSI detached for non-EPS services. In this state the MME accepts SGsAP-PAGING-REQUEST messages to UEs only if the "MME-Reset" restoration indicator in the MME is set to "true".

LA-UPDATE-REQUESTED

The MME has sent an SGsAP-LOCATION-UPDATE-REQUEST message to the VLR. In this state the MME waits for the outcome of the Update Location for non-EPS services procedure at the VLR before sending the response to the UE. In this state the MME accepts SGsAP-PAGING-REQUEST messages.

SGs-ASSOCIATED

The MME stores an SGs association for the UE. In this state the MME performs the location update for non-EPS services procedure towards the VLR for UEs capable of and configured to use CS Fallback when they are moving to a tracking area not in the list of assigned tracking areas.

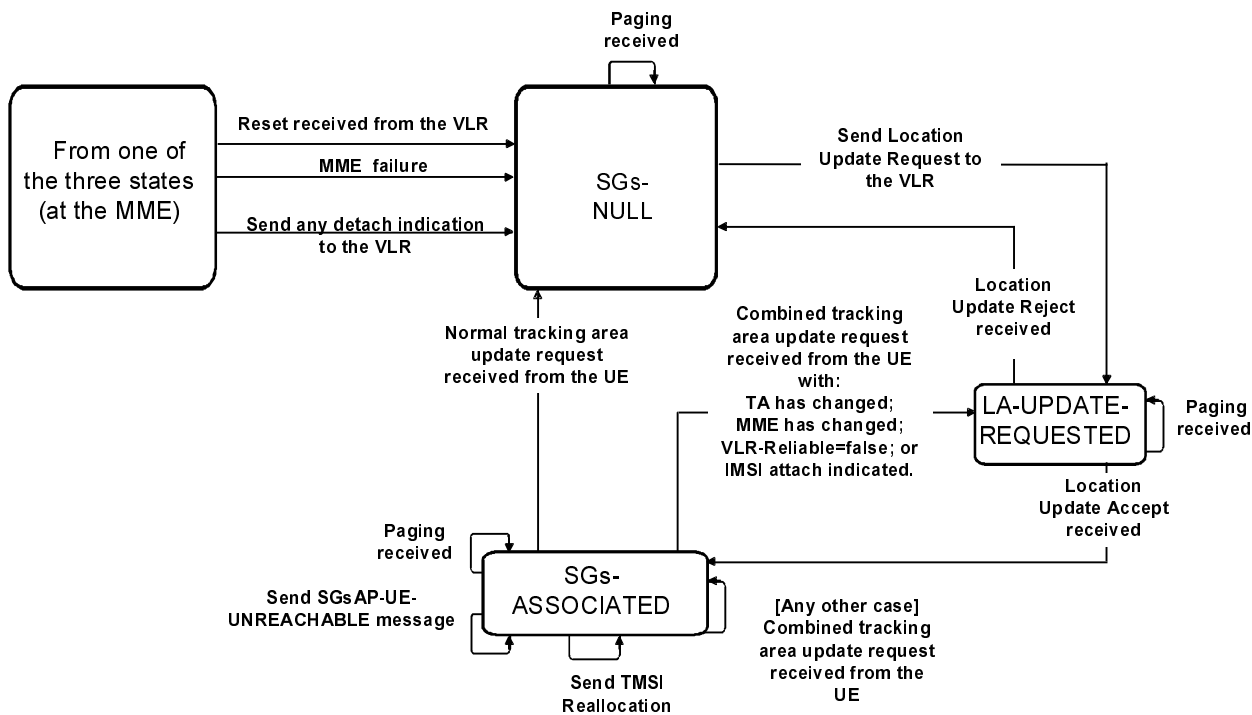

Figure 4.3.3.1: State diagram at the MME

5 Procedures for SGs

5.1 Paging for non-EPS services procedure

5.1.1 General description

This procedure is used by the VLR to send an SGsAP-PAGING-REQUEST message to a UE. This procedure applies to UEs that are simultaneously attached for EPS services and non-EPS services, or for EPS services and SMS only.

5.1.2 Procedures in the VLR

5.1.2.1 General

The VLR shall handle the timers, queuing and retransmission for sending the SGsAP-PAGING-REQUEST message on the SGs interface in the same way that it handles the sending of a PAGING message on the A or Iu interface.

5.1.2.2 Paging Initiation

When a VLR has to page a UE, the VLR shall check whether the VLR has a SGs association for that UE. The VLR sends SGsAP-PAGING-REQUEST messages to the MME if the state of the SGs association for the UE is SGs-ASSOCIATED, LA-UPDATE-PRESENT or if the state of the SGs association is SGs-NULL and the "Confirmed by Radio Contact" restoration indicator is set to "false". The sending of the SGsAP-PAGING-REQUEST message does not change the state of the SGs association with the MME.

If the "Confirmed by Radio Contact" restoration indicator is set to "true", the VLR shall include the Location area identifier information element into the SGsAP-PAGING-REQUEST message, otherwise (i.e. after a VLR failure), the VLR shall not include the Location area identifier information element. When sending the SGsAP-PAGING-REQUEST message, the VLR shall start timer Ts5.

If the state of the SGs association is SGs-NULL and the "Confirmed by Radio Contact" restoration indicator is set to "false", the VLR shall also perform a search procedure as specified in 3GPP TS 23.018 [5].

In this message, the VLR includes the Service indicator information element which will be used to indicate the type of CS service. If the SGs paging request is sent as a result of reception of Provide Subscriber Information Request message, the VLR sets the Service indicator information element to either "SMS indicator" or "CS call indicator" as specified in subclause 7.2.3.5 of 3GPP TS 23.018 [5]. For SMS, SMS indicator is used. For all the other CS services, CS call indicator is used.

If the Calling Line Identification of the service (see 3GPP TS 24.081 [12]) is available in the VLR, the VLR may include the CLI information element in the SGsAP-PAGING-REQUEST message. The conditions specified in 3GPP TS 23.081 [5A] and 3GPP TS 29.011 [15A] apply also here. If the paging is due to a NW-initiated Call Independent SS procedure as defined in 3GPP TS 24.010 [9], the VLR shall include the SS code as defined in 3GPP TS 29.002 [15]. If the paging is due to a Mobile Terminated Location Request as defined in 3GPP TS 24.030 [11], the VLR shall include LCS client identity and LCS indicator as defined in 3GPP TS 29.002 [15] in the SGsAP-PAGING-REQUEST.

While domain specific access control of the PS domain is ongoing, the VLR shall be configured to send paging messages on both the SGs and the A/Iu interface. The VLR may apply implementation specific rules for sending the paging on the A/Iu interface; e.g. paging on the A/Iu interface may be limited to cases when the UE does not respond to a first paging on SGs interface.

5.1.2.3 Paging Response

The VLR stops the paging procedure on expiry of timer Ts5 or on receipt of a SGsAP-SERVICE-REQUEST message from the MME.

NOTE 1: On receipt of an SCCP connection establishment containing the Initial L3 message from the UE via the A or Iu interface, the VLR stops the paging procedure if ongoing, see 3GPP TS 24.008 [8].

Upon receiving the SGsAP-SERVICE-REQUEST message with the UE EMM mode information element indicating "EMM-CONNECTED", the VLR triggers the Call Forwarding on No Reply (CFNRy) as specified in 3GPP TS 23.082 [5B].

If the paging response is received via the A or Iu interface from a location area which differs from the one stored in the VLR, the VLR shall move the SGs association to the SGs-NULL state after the UE has been authenticated successfully.

NOTE 2: UE sends this paging response as a result of receiving paging request with IMSI and with CN domain indicator set to "CS" (see 3GPP TS 24.301 [14]).

5.1.2.4 Paging Failure

On receipt of an SGsAP-PAGING-REJECT message before the timer Ts5 expires, the VLR stops timer Ts5. If the SGs cause information element in the SGsAP-PAGING-REJECT message does not indicate "Mobile terminating CS fallback call rejected by the user", the SGs association is moved to the SGs-NULL state and within this state the SGs association is marked with the contents of the SGs cause information element. If the SGs cause information element in the SGsAP-PAGING-REJECT message indicates "IMSI detached for EPS services" the VLR shall send the paging message on the A/Iu interface. If the SGs cause information element indicates "Mobile terminating CS fallback call rejected by the user", the SGs association state shall not be changed.

When the VLR receives the SGsAP-PAGING-REJECT message with the SGs cause information element indicating "Mobile terminating CS fallback call rejected by the user", the VLR shall trigger User Determined User Busy (UDUB) as specified in 3GPP TS 24.082 [13].

5.1.2.5 UE unreachable

On receipt of an SGsAP-UE-UNREACHABLE message before the timer Ts5 expires, the VLR stops timer Ts5, the paging procedure for that paging request towards the MME is stopped and the VLR applies the equivalent handling as for Call Forwarding on Not Reachable, as specified in 3GPP TS 23.082 [5B] and 3GPP TS 29.011 [15A]. The state of the SGs association at the VLR is not changed.

When the VLR receives the SGsAP-UE-UNREACHABLE message after receipt of the service request message, including the CS call indicator, from the MME, the VLR may trigger Call Forwarding on Not Reachable (CFNRc) as specified in 3GPP TS 23.082 [5B] and 3GPP TS 29.011 [15A]; the SGs association state shall not be changed.

NOTE: If no SCCP connection establishment containing the Initial L3 message from the UE via the A or Iu interface is received, as described in 3GPP TS 24.008 [8], before the timer Ts5 expires, the VLR applies the equivalent handling as for Call Forwarding on Not Reachable, as specified in 3GPP TS 23.082 [5B] and 3GPP TS 29.011 [15A].

5.1.3 Procedures in the MME

5.1.3.1 General

The MME accepts SGsAP-PAGING-REQUEST messages in any state of the SGs association apart from SGs-NULL. When a MME receives a SGs-PAGING-REQUEST message from a VLR, the MME shall first check if the UE is known by the MME. The handling of the paging request depends on the state of the SGs association, the EMM context variables at the MME, and the Service indicator information element in the SGsAP-PAGING-REQUEST message.

If the Service indicator information element in the SGsAP-PAGING-REQUEST message indicates "CS call indicator", the MME shall handle the paging request as follows:

- a) If the UE is known:
 - if the UE is considered to be IMSI attached for EPS services and "SMS only", the MME shall return an SGsAP-PAGING-REJECT message to the VLR indicating in the SGs cause information element "Mobile terminating CS fallback call rejected by the user";
 - if the UE is considered to be IMSI attached for EPS and non-EPS services (i.e. the SGs association is not in the state SGs-NULL), the MME shall page the UE based on the location information stored in the MME. If the location area stored in the MME differs from the one received in the SGsAP-PAGING-REQUEST message, the MME shall use the IMSI to page the UE;
 - if the UE is marked as IMSI detached for EPS services or IMSI (implicitly or explicitly) detached for non-EPS services (i.e. the state of the SGs association is SGs-NULL), the MME shall return an SGsAP-PAGING-REJECT message to that VLR indicating in the SGs cause information element the detach circumstance ("IMSI detached for EPS services", "IMSI detached for non-EPS services" or "IMSI implicitly detached for non-EPS services"); or
 - if the UE is marked as unreachable, indicated by Paging Proceed Flag set to "false", the MME shall return an SGsAP-UE-UNREACHABLE message to that VLR indicating in the SGs cause information element "UE unreachable". The state of the SGs association does not change at the MME.
- b) If the UE is not known and the "MME-Reset" restoration indicator at the MME is set to "false":
 - the MME shall return an SGsAP-PAGING-REJECT message to that VLR indicating in the SGs cause information element "IMSI unknown".
- c) If the UE is not known and the "MME-Reset" restoration indicator at the MME is set to "true", the MME shall handle the paging request as follows:

- if the MME only supports "SMS only", the MME shall return an SGsAP-PAGING-REJECT message to the VLR indicating in the SGs cause information element "Mobile terminating CS fallback call rejected by the user";
- if the SGsAP-PAGING-REQUEST message includes the Location area identifier information element, the MME shall page the UE in all the tracking areas served by the MME that can be mapped to the location area indicated in the Location area identifier information element; or
- if the SGsAP-PAGING-REQUEST message does not include the Location area identifier information element, the MME may page in all the tracking areas served by the MME, or the tracking areas served by the MME and by the VLR.

NOTE: The MME can initiate the paging procedure using IMSI with CN domain indicator set to "PS" to request the UE to initiate the attach procedure as described in 3GPP TS 24.301 [14].

If the Service indicator information element in the SGsAP-PAGING-REQUEST message indicates "SMS indicator", the MME shall handle the paging request as follows:

- a) If the UE is known:
 - if the UE is considered to be IMSI attached for EPS and non-EPS services or IMSI attached for EPS services and "SMS only", the MME shall page the UE based on the location information stored in the MME; or
 - if the UE is marked as IMSI detached for EPS services or IMSI (implicitly or explicitly) detached for non-EPS services, or as unreachable, the MME shall proceed as specified for the case when the service indicator indicates "CS call indicator".
- b) If the UE is not known and the "MME-Reset" restoration indicator at the MME is set to "false":
 - the MME shall return an SGsAP-PAGING-REJECT message to that VLR indicating in the SGs cause information element "IMSI unknown".
- c) If the UE is not known and the "MME-Reset" restoration indicator at the MME is set to "true", the MME shall handle the paging request as follows:
 - if the SGsAP-PAGING-REQUEST message includes the Location area identifier information element, the MME shall page the UE in all the tracking areas served by the MME that can be mapped to the location area indicated in the Location area identifier information element; or
 - if the SGsAP-PAGING-REQUEST message does not include the Location area identifier information element, the MME may page in all the tracking areas served by the MME, or the tracking areas served by the MME and by the VLR.

5.1.3.2 Procedure when no NAS signalling connection exists

If the Service indicator information element in the SGsAP-PAGING-REQUEST message indicates "CS call indicator", the MME shall proceed as follows:

- If the MME accepts the paging request and no NAS signalling connection exists, and the VLR TMSI is omitted or the UE is not known in the MME, the IMSI is used instead of the S-TMSI as a paging address at the radio interface. If location information is reliably known by the MME (i.e. MME stores the list of tracking areas), the MME shall page the UE in all the tracking areas. If the MME does not have a stored tracking area list for the UE, the MME shall use the location information received from the VLR, if any, to page the UE. The MME shall take action as described in 3GPP TS 24.301 [14], subclause 5.6.2.3.

If the Service indicator information element in the SGsAP-PAGING-REQUEST message indicates "SMS indicator", the MME shall use the S-TMSI as paging address at the radio interface and take action as described in 3GPP TS 24.301 [14], subclause 5.6.2.4.

Independent of the Service indicator information element, if the MME has activated Idle mode Signalling Reduction for the UE, the MME shall forward the paging request to the associated SGSN, as described in 3GPP TS 29.274 [17A].

Independent of the Service indicator information element, the MME shall not retransmit the paging message to the UE. Additionally, if the MME has activated Idle mode Signalling Reduction for the UE, the MME shall not retransmit the paging request to the associated SGSN.

5.1.3.3 Procedure when a NAS signalling connection exists

If the Service indicator information element in the SGsAP-PAGING-REQUEST message indicates "CS call indicator", the MME shall proceed as follows:

- If the MME accepts the paging request and a NAS signalling connection exists, the MME shall send the CS SERVICE NOTIFICATION message to the UE through the NAS signalling connection, including the CS service related parameters (CLI, SS code, LCS indicator and LCS client identity), received from the VLR.

If the Service indicator information element in the SGsAP-PAGING-REQUEST message indicates "SMS indicator" and a NAS signalling connection exists, the MME need not take any action towards the UE.

5.2 Location update for non-EPS services procedure

5.2.1 General description

The location update for non-EPS services procedure is a general procedure used by UEs which are configured to use CS fallback and SMS over SGs, or SMS over SGs only. This procedure allows UEs and the network to perform:

- combined IMSI attach for EPS and non-EPS services or for SMS only;
- IMSI attach for non-EPS services or for SMS only if the UE is already IMSI attached for EPS services;
- normal location update procedure to the VLR if the UE is IMSI attached for both EPS and non-EPS services, or for SMS only; or
- allocation of new TMSI to an UE.

The location update for non-EPS services procedure in the SGs interface is always started as a consequence of a direct action from the UE. The combined attach and tracking area update procedures are further specified in 3GPP TS 23.272 [7] and 3GPP TS 24.301 [14].

When a UE is IMSI attached for EPS and non-EPS services, the VLR shall stop any implicit detach timer. Instead the MME uses the "Paging Proceed Flag" to determine the likely availability of the UE to the network. Upon reception of the periodic Tracking Area Update message, the MME does not report to the VLR, and the MME shall not change the state of the SGs association. When the UE performs a detach only for EPS services, the EPS detach indication to the VLR shall cause the VLR's implicit detach timer to be restarted from its initial value.

If the MME performs an implicit detach for both EPS and non-EPS services, then the MME shall send to the VLR an SGsAP-IMSI-DETACH-INDICATION message with cause "Implicit network initiated IMSI detach from non-EPS services", as further described in subclause 5.6 (the implicit IMSI detach message indicates that the UE is unavailable for both EPS and non-EPS services).

5.2.2 Procedures in the MME

5.2.2.1 General

The location update for non-EPS services procedure is initiated with a combined attach or a combined tracking area update procedure. On receipt of an ATTACH REQUEST message or a TRACKING AREA UPDATE REQUEST message from the UE, the MME shall handle the EPS related request as specified in 3GPP TS 24.301 [14]. The location update for non-EPS services procedure is started by the MME when it receives the Update Location Answer message containing subscription data from the HSS. The MME shall wait for the outcome of both location update procedures towards the VLR and the HSS before sending the response message to the UE. If the Update Location Answer message indicates that the UE has subscription for packet only (see 3GPP TS 29.272 [17]), the MME sends the response message to the UE without starting the location update for non-EPS services procedure.

5.2.2.2 Location update initiation

If timer Ts6-1 is not running, the MME shall start the location update for non-EPS services procedure when it receives from the UE:

- an attach request indicating combined EPS/IMSI attach;
- a combined tracking area update request indicating Combined TA/LA updating with IMSI attach;
- a combined tracking area update request and the MME detects that the LAI has changed;
- a combined tracking area update request and the state of the SGs association is SGs-NULL; or
- a combined tracking area update request and the MME serving the UE has changed.

If timer Ts6-1 is not running, the MME may start the location update for non-EPS services procedure when it receives from the UE:

- a combined tracking area update request or a periodic tracking area update, if the MM context variable "VLR-Reliable" for the MS is set to "false" (see subclause 5.7.3).

If multiple PLMNs are available for the CS domain, the MME shall select a PLMN for CS domain as specified in 3GPP TS 23.272 [7]. If the MME cannot select any PLMN for CS domain for the UE, the MME informs the UE that the CS domain is not available.

The MME shall determine the new location area identification as follows:

- if the MME received a combined attach request or combined tracking area update request from the UE with an indication for "SMS only", or the network only supports "SMS only" or the network only has a few VLRs that support SGs interface, the MME may allocate a default location area identification specifically configured for that case;
- else the MME derives the location area identification from the current tracking area identity where the UE is located.

The MME shall derive the VLR name from the location area identification which was determined. In case multiple VLRs serve this location area identification, the MME shall use the location area identification and an IMSI hash value to retrieve the VLR name. The MME shall include the location area identification in the new location area identifier information element in the SGsAP-LOCATION-UPDATE-REQUEST message.

NOTE: The selection of the VLR in the MME follows the same rule as the selection of the VLR in the SGSN, as defined in 3GPP TS 23.236 [6A], and the same IMSI hash values and IMSI hash tables are used by the MME and the SGSN.

In networks supporting the feature "Intra Domain Connection of RAN Nodes to Multiple CN Nodes" as defined in 3GPP TS 23.236 [6A], the MME shall support load re-distribution of UEs to another VLR than the current one. When the MME receives a periodic tracking area update request or a combined tracking area update request, the MME shall check whether for this UE there is a SGs association to a VLR for which load re-distribution has been initiated in the MME by O&M. If this is the case, the MME derives the new VLR name using the new IMSI hash table configured in the MME. The MME shall then send the SGsAP-LOCATION-UPDATE-REQUEST message to the new selected VLR.

The SGsAP-LOCATION-UPDATE-REQUEST message includes the type of location update performed by the UE in the EPS location update type information element. If the UE has performed a combined attach or a combined tracking area update indicating "combined TA/LA updating with IMSI attach", the MME indicates "IMSI attach", otherwise the MME indicates "Normal location update".

The MME shall include the TMSI status in the SGsAP-LOCATION-UPDATE-REQUEST message if the UE indicates in the ATTACH REQUEST or the TRACKING AREA UPDATE REQUEST message that it has no valid TMSI available. The MME shall also include the old location area identifier in the SGsAP-LOCATION-UPDATE-REQUEST message if the UE included the old location area identification in the ATTACH REQUEST or TRACKING AREA UPDATE REQUEST message.

If the MME supports the "Automatic Device Detection" (see 3GPP TS 22.101 [2]) or the "Trace for Management Based Activation/Deactivation" (see 3GPP TS 32.422 [18]), the MME shall include the IMEISV in the SGsAP-LOCATION-UPDATE-REQUEST message.

The MME shall include the UE's current TAI and E-CGI in the SGsAP-LOCATION-UPDATE-REQUEST message.

When the MME sends the SGsAP-LOCATION-UPDATE-REQUEST, the MME shall start timer Ts6-1.

If timer Ts6-1 is running and the MME receives from the UE:

- an attach request indicating combined EPS/IMSI attach; or
- a combined tracking area update with or without IMSI attach.

Then:

- if the LAI determined by the MME is the same as in the outstanding request, the MME shall not process this new request and shall wait for the VLR response to the ongoing procedure;
- if the LAI determined by the MME is different but the VLR name is the same as for previous LAI, any response from the VLR to the outstanding request is ignored, the MME shall stop and reset timer Ts6-1 and the MME shall start the location update for non-EPS services procedure; or
- if the LAI determined by the MME is different and the VLR name is different as for previous LAI, any response from the previously addressed VLR to the outstanding request is ignored, the MME shall stop and reset timer Ts6-1, and the MME shall start the location update for non-EPS services procedure.

When the MME receives from the UE a tracking area update request and the MME serving the UE has changed, the MME shall stop and reset timer Ts6-1.

5.2.2.3 Location update response

If the MME receives an SGsAP-LOCATION-UPDATE-ACCEPT message from the VLR, the MME shall stop timer Ts6-1 and:

- move the state of the SGs association to SGs-ASSOCIATED;
- set the MM context variable "VLR-Reliable" to "true"; and
- indicate to the UE the acceptance of the VLR to the location update procedure. The message sent to the UE includes the Location Area Identity (see 3GPP TS 24.301 [14]).

The MME shall wait for the outcome of the location update for non-EPS services procedure towards the VLR before sending a response to location update procedure to the UE. When the MME receives an SGsAP-LOCATION-UPDATE-REJECT message from the VLR, it will map the reject cause received to the appropriate reject cause as specified in 3GPP TS 24.301 [14], and report this reject cause to the UE.

If the VLR included the Mobile identity information element in the SGsAP-LOCATION-UPDATE-ACCEPT message, the MME shall relay the information received to the UE. If the Mobile identity information element contains a new TMSI, this will cause the UE to perform a TMSI reallocation procedure. In this case, the MME shall send to the VLR the SGsAP-TMSI-REALLOCATION-COMPLETE message when the MME receives the ATTACH COMPLETE or the TRACKING AREA UPDATE COMPLETE message from the UE. If the Mobile identity information element contains an IMSI, this will cause the UE to deallocate its TMSI.

5.2.2.4 Location update failure

If the MME receives an SGsAP-LOCATION-UPDATE-REJECT message from the VLR, the MME shall:

- stop timer Ts6-1;
- move the state of the SGs association to SGs-NULL; and
- indicate to the UE the rejection of the Location Update procedure by the VLR as specified in 3GPP TS 24.301 [14]. The Reject cause value sent by the VLR shall be mapped to the appropriate reject cause as specified in 3GPP TS 24.301 [14], and the latter is forwarded to the UE.

5.2.2.5 Abnormal cases

If timer Ts6-1 expires, the MME shall abort the Location Update for non-EPS service procedure and indicate this to the UE with the Reject cause value 'MSC temporarily not reachable'. The state of the SGs association to the VLR shall be SGs-NULL.

If the MME receives an SGsAP-LOCATION-UPDATE-ACCEPT message and timer Ts6-1 is not running then:

- if timer Ts8 is running (see subclause 5.4), the message shall be ignored;
- if timer Ts9 is running (see subclause 5.5), the message shall be ignored; or
- if timers Ts8 and Ts9 are not running:
 - if the state of the SGs association to the VLR is SGs-ASSOCIATED, the message shall be ignored; or
 - if the state of the SGs association to the VLR is different than SGs-ASSOCIATED, the message shall be treated as a message incompatible with the protocol state of the MME (see subclause 7.3).

5.2.3 Procedures in the VLR

5.2.3.1 General

When a VLR receives an SGsAP-LOCATION-UPDATE-REQUEST message, the VLR shall check whether the IMSI is known. If the IMSI is not known, the VLR shall retrieve the MM context of the UE from the HSS.

5.2.3.2 Location update response

If the location update is accepted by the VLR and, if necessary, by the HSS, the VLR shall:

- move the SGs association to the SGs-ASSOCIATED state;
- set the "Confirmed by Radio Contact" restoration indicator to "true";
- update the SGs association by storing the MME address included in SGsAP-LOCATION-UPDATE-REQUEST message; and
- send an SGsAP-LOCATION-UPDATE-ACCEPT message to the sending MME. This message includes the location area identifier received in the New location area identifier information element in the previous SGsAP-LOCATION-UPDATE-REQUEST message.

5.2.3.3 Location update failure

If the location update is rejected by the VLR, the VLR shall:

- send an SGsAP-LOCATION-UPDATE-REJECT message to the MME with the appropriate reject cause as indicated in 3GPP TS 24.008 [8]; and
- move the SGs association to SGs-NULL.

5.2.3.4 TMSI reallocation procedure

If the VLR decides to allocate a new TMSI to the UE, the VLR shall include the new TMSI in the SGsAP-LOCATION-UPDATE-ACCEPT message. After sending the SGsAP-LOCATION-UPDATE-ACCEPT message with a new TMSI the VLR shall start timer Ts6-2. If the VLR decides to deallocate the TMSI of the UE, the VLR shall include the IMSI of the UE in the SGsAP-LOCATION-UPDATE-ACCEPT message.

Upon receipt of the SGsAP-TMSI-REALLOCATION-COMPLETE message, the VLR shall stop the timer Ts6-2 and consider the new TMSI as valid.

If the IMSI was sent to the UE, the VLR considers the old TMSI as deleted.

If no SGsAP-TMSI-REALLOCATION-COMPLETE message is received by the VLR before the timer Ts6-2 expires, the VLR aborts the TMSI reallocation procedure. The outcome of the TMSI reallocation procedure does not change the state of the SGs association. The VLR uses the IMSI or the new TMSI for paging.

5.2.3.5 Abnormal cases

The following abnormal cases can be identified:

- i) MM signalling via A or Iu interface

If the VLR receives a Location Update request or an IMSI detach indication from the UE by the A or Iu interface when the state of the SGs association in the VLR is not SGs-NULL, the VLR shall move the state of the SGs association to SGs-NULL.

ii) Additional Location Update Request

If the state of the SGs association in the VLR is LA-UPDATE PRESENT and an SGsAP-LOCATION-UPDATE-REQUEST message is received, then:

- if the message is from the same MME and indicates the same New location area identifier information element as the outstanding location update request, then the VLR shall ignore this additional SGsAP-LOCATION-UPDATE-REQUEST message;
- if the message is from the same MME but indicates a different New location area identifier information element to the outstanding location update request, then the VLR shall treat this additional SGsAP-LOCATION-UPDATE-REQUEST message and the VLR shall not send any response to the previous SGsAP-LOCATION-UPDATE-REQUEST message; or
- if the message is from a different MME (indicating either the same or different New location area identifier information element) to the outstanding location update request, then the VLR shall treat this additional SGsAP-LOCATION-UPDATE-REQUEST message and the VLR shall not send any response to the previous SGsAP-LOCATION-UPDATE-REQUEST message.

iii) Detach signalling from the MME

If the state of the SGs association in the VLR is LA-UPDATE PRESENT and either an SGsAP-EPS-DETACH-INDICATION or an SGsAP-IMSI-DETACH-INDICATION message is received, then the VLR shall abandon the Location Update for non-EPS services procedure (neither an SGsAP-LOCATION-UPDATE-ACCEPT nor an SGsAP-LOCATION-UPDATE-REJECT messages is sent) and the further actions described in subclauses 5.4 or 5.5 or 5.6 are followed.

iv) Signalling via Gs interface

If the VLR receives for a UE a BSSAP+-LOCATION-UPDATE-REQUEST message (as defined in 3GPP TS 29.018 [16]) from an SGSN when the state of the SGs association for this UE in the VLR is not SGs-NULL, the VLR shall move the state of the SGs association to SGs-NULL.

5.3 Non-EPS alert procedure

5.3.1 General description

This procedure is used by the VLR to request from an MME an indication when any signalling activity from the UE is detected. This procedure can be invoked at any time by the VLR. The MME shall acknowledge the SGsAP-ALERT-REQUEST message.

5.3.2 Procedures in the VLR

5.3.2.1 Alert Initiation

The VLR may start the Non-EPS alert procedure at any time. When the VLR wants to request from an MME that further activity from a UE is reported by the MME, the VLR shall send an SGsAP-ALERT-REQUEST message to that MME. The VLR starts timer Ts7 when the SGsAP-ALERT-REQUEST message is sent.

5.3.2.2 Alert Response

When an SGsAP-ALERT-ACK message is received, the VLR shall stop the timer Ts7. The state of the SGs association is not changed.

5.3.2.3 Alert Failure

If an SGsAP-ALERT-REJECT message is received, the VLR shall stop the timer Ts7, move the state of the SGs association to SGs-NULL and within this state the SGs association is marked with the contents of the SGs cause information element.

5.3.2.4 Alert Indication

The VLR shall not change the state of the SGs association upon reception of an SGsAP-UE-ACTIVITY-INDICATION message.

5.3.2.5 Abnormal cases

If no SGsAP-ALERT-ACK message is received before the timer Ts7 expires, the VLR shall retransmit the SGsAP-ALERT-REQUEST message a maximum of Ns7 times.

NOTE: If no SGsAP-ALERT-ACK message is received after that, a report is made to the O&M system. The state of the SGs association is not changed.

5.3.3 Procedures in the MME

5.3.3.1 Alert response

The MME may receive an SGsAP-ALERT-REQUEST message in any state of the SGs association. Upon receipt of an SGsAP-ALERT-REQUEST message from the VLR and if the IMSI is known in the MME, the MME shall reply with an SGsAP-ALERT-ACK message and set the NEAF. If the MME has activated Idle mode Signalling Reduction for the UE, the MME shall send an Alert MME Notification message to the associated SGSN, as described in 3GPP TS 29.274 [17A], except for the conditions specified in subclause 8.2.5c of 3GPP TS 23.272 [7].

5.3.3.2 Alert failure

If an SGsAP-ALERT-REQUEST message is received for an IMSI that is unknown at the MME, the MME shall return an SGsAP-ALERT-REJECT message to the VLR indicating the SGs cause information element value "IMSI unknown".

5.3.3.3 Alert indication

The MME shall report to the VLR upon detection of any activity in E-UTRAN (either signalling or, indirectly detected via S-GW, data transfer) from the UE if the NEAF is set. If the MME detects EPS signalling that leads to a procedure towards the VLR, the MME shall follow this procedure and reset the NEAF. If the MME detects activity that does not lead to any procedure towards the VLR, the MME shall send an SGsAP-UE-ACTIVITY-INDICATION message towards the VLR and reset the NEAF. Upon receipt of a UE Activity Notification message from the SGSN, the MME shall reply with a UE Activity Acknowledge message, send an SGsAP-UE-ACTIVITY-INDICATION message to the VLR and reset the NEAF flag.

5.4 Explicit IMSI detach from EPS services

5.4.1 General description

This procedure is used by the MME to indicate to the VLR that the UE has been detached from EPS services and therefore the SGs association between the MME and the VLR has to be deactivated. This procedure only applies to UEs which are not in the SGs-NULL state at the MME. The procedures specified in this subclause apply to EPS detach indication initiated by the UE or by the network as specified in 3GPP TS 24.301 [14].

The procedure is also used by the MME to indicate to the VLR when a combined tracking area update procedure has been rejected by the MME or the MME receives the Detach Notification from the SGSN, as described in 3GPP TS 29.274 [17A], when Idle mode Signalling Reduction is activated.

The Explicit IMSI detach from EPS services procedure aborts any other ongoing procedure related to this UE on the SGs interface in the MME and in the VLR.

5.4.2 Procedures in the MME

5.4.2.1 Explicit EPS detach indication

The MME shall send an SGsAP-EPS-DETACH-INDICATION message to a VLR if:

- the MME receives a detach for EPS from the UE;
- the MME performs network initiated EPS detach procedure;
- the combined tracking area update procedure is rejected by the MME; or
- the MME receives a Detach Notification from the SGSN with the Detach type indicating "PS Detach".

If the MME receives a Detach Request from a UE or Detach Notification from an SGSN and the state of the SGs association to a VLR for that UE is not SGs-NULL, the MME shall check the detach type indicated in the Detach Request message or the detach type indicated in the Detach Notification message. If the UE has indicated EPS detach the MME shall send an SGsAP-EPS-DETACH-INDICATION message to the VLR indicating "UE initiated IMSI detach from EPS services".

If the MME decides to perform a network initiated detach procedure and the state of the SGs association to a VLR for that MS is not SGs-NULL, the MME shall send an SGsAP-EPS-DETACH-INDICATION message to the VLR indicating "MME initiated IMSI detach from EPS services".

If the combined tracking area update procedure is rejected at the MME for a UE with an SGs association state different from SGs-NULL, the MME shall send an SGsAP-EPS-DETACH-INDICATION to the VLR indicating "EPS services not allowed".

After sending of the SGsAP-EPS-DETACH-INDICATION message, the MME shall move the state of the SGs association to SGs-NULL. The MME shall start timer Ts8 upon transmission of the SGsAP-EPS-DETACH-INDICATION message and the MME shall stop and reset timer Ts6-1 if running.

5.4.2.2 Explicit EPS detach response

If a confirmation of the detach needs to be sent to the UE, the MME shall not wait for the reception of the SGsAP-EPS-DETACH-ACK message to send such confirmation.

5.4.2.3 Abnormal cases

If no SGsAP-EPS-DETACH-ACK message is received by the MME in response to a previous SGsAP-EPS-DETACH-INDICATION message before timer Ts8 expires, the MME shall repeat the SGsAP-EPS-DETACH-INDICATION message a maximum of Ns8 times.

NOTE: If no SGsAP-EPS-DETACH-ACK message is received after that, a report is made to the O&M system. The state of the SGs association during the acknowledgement procedure remains SGs-NULL.

5.4.3 Procedures in the VLR

When a VLR receives an SGsAP-EPS-DETACH-INDICATION message, the VLR shall send an SGsAP-EPS-DETACH-ACK message to the sending MME. The VLR shall check the MME name indicated in the SGsAP-EPS-DETACH-INDICATION message. If the received MME name is not changed comparing to the MME name stored in the VLR, the VLR shall move the state of the SGs association for the UE from any state to SGs-NULL and marks the SGs association as "detached for EPS services" with the reason indicated in the IMSI detach from EPS service type information element. Otherwise, the VLR shall discard the SGsAP-EPS-DETACH-INDICATION message and the state of the SGs association shall not be changed.

If the VLR's implicit detach timer is not running then the VLR shall set and restart the implicit detach timer upon reception of an SGsAP-EPS-DETACH-INDICATION message. If the VLR's implicit detach timer is running (the state

of the SGs association was already SGs-NULL) then the reception of an SGsAP-EPS-DETACH-INDICATION message shall not affect VLR's implicit detach timer.

5.5 Explicit IMSI detach from non-EPS services

5.5.1 General description

This procedure is used by the MME to indicate to the VLR that the UE has performed IMSI detach from non-EPS services and therefore the SGs association between the MME and the VLR has to be deactivated. This procedure applies only to UEs for which there is a SGs association at the MME. The procedures specified in this subclause apply only to IMSI detach request, combined IMSI and EPS detach requests from the UE or Detach Notification message from an SGSN.

The explicit IMSI detach from non-EPS services procedure aborts any other ongoing procedure related to this UE on the SGs interface in the MME and in the VLR.

In order to ensure that the VLR and the UE are synchronized as to which paging channel to use for any of the subsequent paging events, the MME shall attempt to inform the VLR about the detach event by using a retry scheme if the initial delivery of the SGsAP-IMSI-DETACH-INDICATION message fails.

5.5.2 Procedures in the MME

5.5.2.1 Explicit IMSI detach initiation

When an MME receives a Detach Request from a UE for which an SGs association exists, the MME shall check the detach type indicated. If the UE is indicating IMSI detach or combined EPS/IMSI detach, the MME shall send an SGsAP-IMSI-DETACH-INDICATION message to the VLR indicating "Explicit UE initiated IMSI detach from non-EPS services" or "Combined UE initiated IMSI detach from EPS and non-EPS services".

When an MME receives a Detach Notification message for a UE from an SGSN and an SGs association for the UE exists, the MME shall check the cause and detach type indicated. If the cause is indicating "IMSI Detach only", the MME shall send an SGsAP-IMSI-DETACH-INDICATION message to the VLR indicating "Explicit UE initiated IMSI detach from non-EPS services". If the cause is indicating "Complete Detach" and detach type is indicating "Combined PS/CS Detach" as specified in 3GPP TS 29.274 [17A], the MME shall send an SGsAP-IMSI-DETACH-INDICATION message to the VLR indicating "Combined UE initiated IMSI detach from EPS and non-EPS services".

After the sending of the SGsAP-IMSI-DETACH-INDICATION message to the VLR, the MME shall move the state of the SGs association to SGs-NULL. The MME shall start timer Ts9 upon transmission of the SGsAP-IMSI-DETACH-INDICATION message and the MME shall stop and reset timer Ts6-1, if running.

5.5.2.2 Explicit IMSI detach response

If the detach type received from the UE indicated IMSI only detach or combined EPS/IMSI detach not due to switch off, the MME shall wait for the reception of the SGsAP-IMSI-DETACH-ACK message before sending the confirmation of the detach to the UE.

5.5.2.3 Abnormal cases

The following abnormal cases can be identified:

- i) no SGsAP-IMSI-DETACH-ACK received for a detach with switch off

If the MME sent an SGsAP-IMSI-DETACH-INDICATION message for a combined IMSI and EPS detach due to switch off and timer Ts9 expires, the MME shall repeat the SGsAP-IMSI-DETACH-INDICATION message a maximum of Ns9 times.

- ii) no SGsAP-IMSI-DETACH-ACK received for a detach with no switch off

If the MME sent an SGsAP-IMSI-DETACH-INDICATION message for an IMSI only detach or a combined IMSI and EPS detach not due to switch off and timer Ts9 expires, the MME shall repeat the SGsAP-IMSI-

DETACH-INDICATION message a maximum of N_{s9} times. If no SGsAP-IMSI-DETACH-ACK is received after that the MME shall send the confirmation of the detach to the UE.

5.5.3 Procedures in the VLR

When a VLR receives an SGsAP-IMSI-DETACH-INDICATION message, the VLR shall send an SGsAP-IMSI-DETACH-ACK message to the sending MME. The VLR shall move the state of the SGs association for the UE from any state to SGs-NULL. If the SGsAP-IMSI-DETACH-INDICATION message indicated "Explicit UE initiated IMSI detach from non-EPS services", the VLR marks the SGs association as "IMSI detached for non-EPS services". If the SGsAP-IMSI-DETACH-INDICATION message indicated "Combined UE initiated IMSI detach from EPS and non-EPS services", the VLR marks the SGs association as "IMSI detached for EPS and non-EPS services".

5.6 Implicit IMSI detach from non-EPS services

5.6.1 General description

This procedure is used by the MME to indicate when an internal MME timer mechanism has caused the MME to delete the EMM context of an UE or mark its EMM context as detached. This procedure only applies to UEs for which there is an SGs association at the MME.

The implicit IMSI detach from non-EPS services procedure aborts any other ongoing procedure related to this UE on the SGs interface in the MME and in the VLR.

In order to ensure that the VLR and the UE are synchronized as to which paging channel to use for any of the subsequent paging events the MME shall attempt to inform the VLR about the detach event by using a retry scheme if the initial delivery of the SGsAP-IMSI-DETACH-INDICATION message fails.

5.6.2 Procedures in the MME

When the implicit IMSI detach from non-EPS services procedure is started for a UE by the above mentioned internal MME timer mechanism, the MME shall send an SGsAP-IMSI-DETACH-INDICATION message to the VLR indicating "Implicit network initiated IMSI detach from non-EPS services".

After the sending of the SGsAP-IMSI-DETACH-INDICATION message, the MME shall move the state of the SGs association to SGs-NULL. The MME shall start timer T_{s10} upon transmission of the SGsAP-IMSI-DETACH-INDICATION message.

If no SGsAP-IMSI-DETACH-ACK message is received by the MME to a previous SGsAP-IMSI-DETACH-INDICATION message before timer T_{s10} expires, the MME shall repeat the SGsAP-IMSI-DETACH-INDICATION message a maximum of N_{s10} times. The state of the SGs association during the acknowledgement procedure remains SGs-NULL.

5.6.3 Procedures in the VLR

When a VLR receives the SGsAP-IMSI-DETACH-INDICATION message and the state of the SGs association is not SGs-NULL, the VLR shall move the state of the SGs association for the UE to SGs-NULL. The VLR marks the SGs association as "IMSI implicitly detached for EPS and non-EPS services". The VLR shall also send an SGsAP-IMSI-DETACH-ACK message to the sending MME.

When a VLR receives the SGsAP-IMSI-DETACH-INDICATION message and the state of the SGs association is SGs-NULL, the VLR shall send an SGsAP-IMSI-DETACH-ACK message to the sending MME.

5.7 VLR failure procedure

5.7.1 General description

This procedure is used by the VLR to inform the MMEs with an SGs association about the recovery from an internal failure that has affected the SGs association with the MMEs.

NOTE: The VLR recovery procedure is handled in such a way that the signalling load on the VLR and MMEs does not create any overload problem.

5.7.2 Procedures in the VLR

5.7.2.1 VLR Reset Initiation

In the event of a failure at the VLR which has resulted in the loss of the SGs association information for some UEs, the VLR shall move from any state to the SGs-NULL state for all the SGs associations with MMEs per UE. The VLR shall also set the "Confirmed by Radio Contact" restoration indicator to "false" (see 3GPP TS 23.007 [4]). The VLR shall not send any SGsAP-MM-INFORMATION-REQUEST messages to UEs with the SGs association in the SGs-NULL state.

When the VLR restarts, the VLR shall send an SGsAP-RESET-INDICATION message to all the MMEs connected to the VLR by the SGs interface. This message indicates to the MME that for the UEs with an SGs association to that VLR, the SGs associations are no longer reliable. The VLR shall also start a separate timer Ts11 for each MME.

5.7.2.2 VLR Reset Response

Upon receipt of an SGsAP-RESET-ACK message from an MME, the VLR shall stop the timer Ts11 for that MME.

5.7.2.3 Abnormal cases

If the VLR does not receive an SGsAP-RESET-ACK message from that MME before the timer Ts11 expires, the VLR shall retransmit the SGsAP-RESET-INDICATION message. The retransmission is repeated a maximum of Ns11 times.

NOTE: If no SGsAP-RESET-ACK is received after that a report is made to the O&M system.

5.7.3 Procedures in the MME

Upon receipt of an SGsAP-RESET-INDICATION message from the VLR, the MME is informed that all the SGs associations with that VLR for all the UEs registered in the MME are no longer reliable because the VLR has lost information about the state of the UEs and during the failure the VLR might have missed signalling messages. The MME shall set the "VLR-Reliable" MM context variable to "false". The detach procedures for deleting the SGs association are still applicable (see subclauses 5.4, 5.5 and 5.6). If the "VLR-Reliable" MM context variable is set to "false", upon reception of a Combined Tracking Area update request or a periodic Tracking Area Update from the UE that is attached for non-EPS service, the MME may request the re-attach to non-EPS services, or may alternatively immediately perform the Location Update for non-EPS services procedure towards the VLR as described in subclause 5.2.

The MME sends an SGsAP-RESET-ACK message to the VLR.

5.8 MME failure procedure

5.8.1 General description

This procedure is used by the MME to inform the associated VLRs about the recovery from an internal failure that has affected the SGs association with the VLRs.

NOTE: The MME recovery procedure is handled in such a way that the signalling load on the MME and VLRs does not create any overload problem.

5.8.2 Procedures in the MME

5.8.2.1 MME Reset Initiation

In the event of a failure at the MME which has resulted in the loss of the SGs association information on some UEs, the MME shall move from any state to the SGs-NULL state all the SGs associations with VLRs per UE. The MME shall

also set the "MME-Reset" MM context variable to "true" and start the timer Ts12-1. When the timer Ts12-1 expires the "MME-Reset" MM context variable is set to "false".

The MME may send an SGsAP-RESET-INDICATION message to all the VLRs connected to the MME by SGs interfaces. The SGsAP-RESET-INDICATION message indicates to the VLR that all the SGs associations with that particular MME for all the UEs registered in the VLR are no longer reliable. The normal procedures for updating the SGs association are still applicable (see subclauses 5.2, 5.4, 5.5 and 5.6). The MME shall also start a separate timer Ts12-2 for each VLR.

If the MME does not send an SGsAP-RESET-INDICATION message, the MME shall move from any state to the SGs-NULL state only the associations of the UEs affected by the loss of VLR association information.

NOTE: The option to not send any SGsAP-RESET-INDICATION message to all the VLRs connected to the MME by SGs interfaces reduces subsequent paging signalling initiated by VLRs by avoiding a complete search of the UE on the entire VLR area.

5.8.2.2 MME Reset Response

Upon receipt of an SGsAP-RESET-ACK message, the MME shall stop the timer Ts12-2 for that VLR.

5.8.2.3 Abnormal cases

If the MME does not receive an SGsAP-RESET-ACK message from that VLR before the timer Ts12-2 expires, the MME shall retransmit the SGsAP-RESET-INDICATION message. The retransmission is repeated a maximum of Ns12 times.

NOTE: If no SGsAP-RESET-ACK is received after that a report is made to the O&M system.

5.8.3 Procedures in the VLR

Upon receipt of an SGsAP-RESET-INDICATION message from the MME, the VLR is informed that all the SGs associations with that MME for all the UEs registered in the MME are no longer reliable because the MME has lost information about the state of the UEs for that VLR and during the failure the MME might have missed signalling messages. The VLR shall either:

- set the "Confirmed by Radio Contact" restoration indicator to "false" in all the SGs associations containing the restarted MME and set the state of all the SGs associations containing the restarted MME to the SGs-NULL state; or
- keep the 'Confirmed by Radio Contact' restoration indication and the state of all the SGs associations containing the restarted MME unchanged.

NOTE: The option to not set the 'Confirmed by Radio Contact' restoration indicator to 'false' in all the associations containing the restarted MME reduces subsequent paging signalling the VLR can initiate by avoiding a complete search of the UE on the entire VLR area.

The VLR shall then send an SGsAP-RESET-ACK message to the MME.

If the "Confirmed by Radio Contact" restoration indicator is "false" the VLR may send paging messages on both the SGs and the A/Iu interface.

5.9 HSS failure

5.9.1 General description

This subclause describes the MME behaviour towards the VLR as a consequence of an HSS reset.

In the case of an HSS failure, the HSS informs the associated MMEs about the recovery from an internal failure that has affected the SGs association with the MMEs according to the HSS reset procedure specified in 3GPP TS 29.272 [17].

This information is used in the MME to trigger the VLR to perform a location update towards the HSS in order to restore the HSS subscriber data.

5.9.2 Procedures in the MME

Upon receipt of a HSS reset indication from the HSS, the MME shall set the NEAF for all registered UEs in the MME for which a valid SGs association with a VLR exists.

Upon detection of any signalling activity from the UE, the MME shall report to the VLR if the NEAF, as defined in subclause 5.3.3, is set for this UE. If the MME detects signalling that leads to a procedure towards the VLR, the MME shall follow this procedure and reset the NEAF. If the MME detects activity that does not lead to any procedure towards the VLR, the MME shall send an SGsAP-UE-ACTIVITY-INDICATION message towards the VLR and reset the NEAF. The MME may delay sending the activity indication for a maximum operator-configuration depending time period to avoid high signalling load.

5.10 MM information procedure

5.10.1 General description

The MM information procedure is performed between the VLR and the MME via the SGs interface if the target UE for the MM information procedure is IMSI attached to both EPS and non-EPS services (i.e. the state of the SGs association is SGs-ASSOCIATED). The outcome of the MM Information procedure does not change the state of the SGs association at the VLR or MME.

5.10.2 Procedures in the VLR

If for the target UE for the MM information procedure the state of the SGs association in the VLR is SGs-ASSOCIATED, the VLR may initiate the MM information procedure by transferring an SGsAP-MM-INFORMATION-REQUEST message to the MME.

5.10.3 Procedures in the MME

If an SGsAP-MM-INFORMATION-REQUEST message is received for a UE for which there exists an SGs association at the MME, the MME shall forward the contents of the MM information information element to the UE indicated in the SGsAP-MM-INFORMATION-REQUEST message, using an EMM INFORMATION message as defined in 3GPP TS 24.301 [14].

5.11 Procedure for tunnelling of NAS messages

5.11.1 General description

The tunnelling of NAS messages procedure is used to encapsulate the NAS messages exchanged between the UE and the VLR. This procedure can be used by either the VLR or the MME depending on the direction of the NAS message. The two procedures are identified as uplink unitdata, in the direction from the MME to the VLR, and downlink unitdata in the direction from the VLR to the MME.

5.11.2 Uplink unitdata procedure

5.11.2.1 Procedures in the MME

When the MME receives an Uplink NAS Transport message (see 3GPP TS 24.301 [14]) from a UE, the MME shall copy the value part of the NAS message container information element to the value part of the NAS message container information element of the SGsAP-UPLINK-UNITDATA message and send the SGsAP-UPLINK-UNITDATA message to the VLR.

In order to permit the VLR to create an accurate charging record, the MME shall add the IMEISV, the UE Time Zone, the Mobile Station Classmark 2, and the UE's current TAI and E-CGI to the SGsAP-UPLINK-UNITDATA message.

5.11.2.2 Procedures in the VLR

Upon reception of an SGsAP-UPLINK-UNITDATA, the VLR shall extract the NAS message container information element and treat the value part of this information element according to the procedures defined in 3GPP TS 24.011 [10].

Other parameters in the message may be used as specified in 3GPP TS 32.250 [17B] and 3GPP TS 23.078 [5AA].

5.11.2.3 Abnormal cases

The following abnormal case can be identified:

- i) if there is no SGs association for the UE at the VLR

If the VLR receives an SGsAP-UPLINK-UNITDATA from the MME for a UE for which no SGs association exists, then the VLR shall ignore the received message.

5.11.3 Downlink unitdata procedure

5.11.3.1 Procedures in the VLR

When the VLR needs to send a NAS message to the UE, the VLR shall first verify whether or not it has an SGs association for the UE. If the state of the SGs association for the UE is SGs-ASSOCIATED and LA-UPDATE-PRESENT, then the VLR continues with the procedure. The VLR shall build and encapsulate the NAS message into the value part of the NAS message container information element of an SGsAP-DOWNLINK-UNITDATA message and send the SGsAP-DOWNLINK-UNITDATA message to the MME.

5.11.3.2 Procedures in the MME

Upon reception of an SGsAP-DOWNLINK-UNITDATA message, the MME shall copy the value part of the NAS message container information element to the value part of the NAS message container information element of a Downlink NAS Transport message (see 3GPP TS 24.301 [14]) and send the Downlink NAS Transport message to the UE.

5.11.3.3 Abnormal cases

The following abnormal case can be identified:

- i) if there is no SGs association for the UE at the MME

If the MME receives an SGsAP-DOWNLINK-UNITDATA message from the VLR for a UE for which there is no SGs association, then the MME shall ignore the received message.

5.11.4 Release procedure

When the VLR determines that there are no more NAS messages to be exchanged between the VLR and the UE, the VLR shall send the SGsAP-RELEASE-REQUEST message to the MME, including the IMSI of the UE for which there are no more NAS messages to be tunnelled.

NOTE: For the SMS transport, the VLR can send the SGsAP-RELEASE-REQUEST message when the SMS transaction is complete (reception of a CP-ACK message for the MO case, sending of a CP-ACK message for the MT case), upon reception of a CP-ERROR message, abort of SMS transaction by upper layers, or upon some error cases such as TC1 expiry.

This indication can be used by the MME to control the release of the NAS signalling connection with the UE indicated in the SGsAP-RELEASE-REQUEST message.

5.12 Service request procedure

5.12.1 General description

After the reception of an SGsAP-PAGING-REQUEST message from the VLR, the MME will use this procedure to indicate to the VLR that a NAS signalling connection exists between the UE and the MME. The procedure can be invoked, by the MME, either upon reception of a Service Request message from the UE or directly after receiving the SGsAP-PAGING-REQUEST message from the VLR, based on the UE's EMM mode.

5.12.2 Procedures in the MME

When receiving the SGsAP-PAGING-REQUEST message, the MME shall first take action as described in subclause 5.1.3 and check whether the UE, for which the paging is sent, is in EMM-IDLE or EMM-CONNECTED mode.

If the MME accepts the paging request, the MME shall proceed as follows:

- If the UE was in EMM-CONNECTED mode, the MME shall immediately create and send an SGsAP-SERVICE-REQUEST message to the VLR. If the UE subsequently rejects the CS fallback call, the MME shall send the SGsAP-PAGING-REJECT message to the VLR with the SGs cause information element indicating "Mobile terminating CS fallback call rejected by the user"; or
- If the UE was in EMM-IDLE mode, the MME shall send the SGsAP-SERVICE-REQUEST message to the VLR when the UE enters EMM-CONNECTED mode.

In both EMM-IDLE and EMM-CONNECTED modes, the MME shall set the service indicator in the SGsAP-SERVICE-REQUEST message equal to what was received in the SGsAP-PAGING-REQUEST message. Additionally, in order to permit the VLR to create an accurate charging record, the MME shall add the IMEISV, the UE Time Zone, the Mobile Station Classmark 2, and the UE's current TAI and E-CGI to the SGsAP-SERVICE-REQUEST message.

5.12.3 Procedures in the VLR

Upon reception of the SGsAP-SERVICE-REQUEST message, the VLR shall stop Timer Ts5 and consider the paging procedure as successful. If the paging procedure is for SMS, the VLR shall then start the delivery of the SMS message(s) according to the subclause 5.11.3.1. If the paging procedure with the Service indicator information element indicating "SMS Indicator" was triggered upon reception of a Provide Subscriber Information Request message, the VLR can return an SGsAP-RELEASE-REQUEST message to the MME as specified in subclause 7.2.3.5 of 3GPP TS 23.018 [5].

Other parameters in the message may be used as specified in 3GPP TS 32.250 [17B] and 3GPP TS 23.078 [5AA].

6 SGs transport

6.1 General

This subclause specifies the standards for signalling transport to be used across SGs interface. SGs interface is a logical interface between the MME and the VLR. All the SGsAP messages described in the present document require an SCTP association between the MME and the VLR.

6.2 IP layer

The MME and the VLR shall support IPv6 (see IETF RFC 2460 [22]) and/or IPv4 (see IETF RFC 791 [20]).

The IP layer of SGs only supports point-to-point transmission for delivering SGsAP messages.

6.3 Transport layer

SCTP (see IETF RFC 4960 [23]) shall be supported as the transport layer of SGsAP messages.

Semi-permanent SCTP associations shall be established between the MME and VLR, i.e. the SCTP associations shall remain up under normal circumstances.

Transport network redundancy can be achieved by SCTP multi-homing between two end-points, of which one or both is assigned with multiple IP addresses. SCTP end-points shall support a multi-homed remote SCTP end-point. For SCTP endpoint redundancy, an SCTP endpoint (in the MME or VLR) may send an INIT, at any time for an already established SCTP association, which the other SCTP endpoint shall handle as defined in IETF RFC 4960 [23].

MME and VLR shall support a configuration with a single SCTP association per MME/VLR pair. Configurations with multiple SCTP endpoints per MME/VLR pair may be supported.

Within the SCTP association established between one MME and one VLR, both MME and VLR shall reserve several stream identifiers, based on the INIT message exchange for the sole use of SGsAP procedures.

The MME shall establish the SCTP association.

The registered port number for SGsAP is 29118.

The payload protocol identifier to be used for SGsAP is 0.

7 Error handling

7.1 General

This subclause specifies procedures for the handling of unknown, unforeseen, and erroneous protocol data by the receiving entity (i.e. the MME or the VLR). These procedures are called "error handling procedures", but in addition to providing recovery mechanisms for error situations they define a compatibility mechanism for future extensions of the protocol.

In this subclause the following terminology is used:

- an information element is defined to be syntactically incorrect in a message if it contains at least one value defined as "reserved", or if its value part violates coding rules. However, it is not a syntactical error that an information element indicates in its Length Indicator a greater length than defined in the relevant subclause; and
- a message is defined to have semantically incorrect contents if it contains information which, possibly dependant on the state of the receiver, is in contradiction to the resources of the receiver and/or to the procedural part of current specification.

When a receiving entity detects the need to send an SGsAP-STATUS message (see errors detailed below), the entity shall copy the IMSI information element value (if included) of the incorrect message to the IMSI information element of the SGsAP-STATUS message. The message in error is also included in the SGsAP-STATUS message. Both the receiving and the sending entity shall abandon the procedure related to the incorrect message and return to the state from where the procedure related to the incorrect message was started.

Both the receiving and the sending entity shall inform the O&M entity upon sending or receiving an SGsAP-STATUS message.

The next subclauses shall be applied in order of precedence.

7.2 Message too short

When the receiving entity receives a message that is too short to contain a complete message type information element, the receiving entity shall ignore that message.

7.3 Unknown or unforeseen message type

The entity receiving a message with a message type not defined or not implemented shall ignore the message. The receiving entity shall return an SGsAP-STATUS message with the SGs cause information element set to "message unknown" and the Erroneous message information element containing the received message.

The entity receiving a message that is not compatible with the protocol state shall return an SGsAP-STATUS message with the SGs cause information element set to "message not compatible with the protocol state" and the erroneous message.

The entity receiving a message that is not defined to be received by that entity (i.e. the message is sent in the wrong direction) shall treat the message as unknown message and shall ignore the message. The entity shall return an SGsAP-STATUS message with the SGs cause information element set to "message unknown" and the Erroneous message information element containing the received message.

7.4 Missing mandatory information element

When the receiving entity diagnoses a "missing mandatory information element" error, the receiving entity shall ignore the message and return an SGsAP-STATUS message with the SGs cause information element set to "missing mandatory information element" and shall return the Erroneous message information element containing the received message.

7.5 Information elements unknown or unforeseen in the message

The receiving entity shall ignore all information elements unknown or unforeseen in a message.

7.6 Out of sequence information elements

The receiving entity shall ignore all information elements that are out of sequence.

7.7 Repeated information elements

If an information element with format T, TV, or TLV is repeated in a message in which repetition of the information element is not specified, the receiving entity shall only handle the contents of the information element appearing first and shall ignore all subsequent repetitions of the information element. When repetition of information elements is specified, the receiving entity shall only handle the contents of specified repeated information elements. If the limit on repetition of information elements is exceeded, the receiving entity shall handle the contents of information elements appearing first up to the limit of repetitions and shall ignore all subsequent repetitions of the information element.

7.8 Syntactically incorrect mandatory information element.

On receipt of a message which contains a syntactically incorrect mandatory information element, the receiver shall ignore the message and return an SGsAP-STATUS message with the SGs cause information element set to "invalid mandatory information" and shall return the Erroneous message information element containing the received message.

7.9 Syntactically incorrect optional information elements

The receiving entity shall treat all optional information elements that are syntactically incorrect in a message as not present in the message.

7.10 Conditional information element errors

When the entity receiving a message diagnoses a "missing conditional information element" error or an "unexpected conditional information element" error or when it receives a message containing at least one syntactically incorrect conditional information element which is required to be present in the message, the receiving entity shall ignore the message and return an SGsAP-STATUS message with the SGs cause information element set to "conditional information element error" and shall return the Erroneous message information element containing the received message.

When the entity receives a message containing a syntactically incorrect conditional information element which is not required to be present in the message, nor required to be absent in the message, then the receiving entity shall ignore that information element.

7.11 Information elements with semantically incorrect contents

When an information element with semantically incorrect contents is received, the foreseen reactions of the procedural part of the present specification are performed.

If however no such reactions are specified, the receiving entity shall ignore that information element and treat the rest of the message. If, because this information element was ignored, the rest of the message can no longer be handled then the receiving entity shall return an SGsAP-STATUS message with the SGs cause information element set to "semantically incorrect message" and shall return the Erroneous message information element containing the received message.

8 Message functional definitions and contents

8.1 SGsAP-ALERT-ACK message

This message is sent by the MME to the VLR to acknowledge a previous SGsAP-ALERT-REQUEST message. Table 8.1.1 shows the content of the SGsAP-ALERT-ACK message.

Table 8.1.1: SGsAP-ALERT-ACK message content

Information element	Type/Reference	Presence	Format	Length
Message type	Message type 9.2	M	V	1
IMSI	IMSI 9.4.6	M	TLV	6-10

8.2 SGsAP-ALERT-REJECT message

This message is sent from the MME to the VLR to indicate that the MME could not identify the IMSI indicated in the SGsAP-ALERT-REQUEST message. Table 8.2.1 shows the content of the SGsAP-ALERT-REJECT message.

Table 8.2.1: SGsAP-ALERT-REJECT message content

Information element	Type/Reference	Presence	Format	Length
Message type	Message type 9.2	M	V	1
IMSI	IMSI 9.4.6	M	TLV	6-10
SGs Cause	SGs cause 9.4.18	M	TLV	3

8.3 SGsAP-ALERT-REQUEST message

This message is sent by the VLR to the MME to request an indication when the next activity of a UE is detected. Table 8.3.1 shows the content of the SGsAP-ALERT-REQUEST message.

Table 8.3.1: SGsAP-ALERT-REQUEST message content

Information element	Type/Reference	Presence	Format	Length
Message type	Message type 9.2	M	V	1
IMSI	IMSI 9.4.6	M	TLV	6-10

8.4 SGsAP-DOWNLINK-UNITDATA message

This message is sent from the VLR to the MME to transparently relay a NAS message, from the VLR, to the UE. Table 8.4.1 shows the content of the SGsAP-DOWNLINK-UNITDATA message.

Table 8.4.1: SGsAP-DOWNLINK-UNITDATA message content

Information element	Type/Reference	Presence	Format	Length
Message type	Message type 9.2	M	V	1
IMSI	IMSI 9.4.6	M	TLV	6-10
NAS message container	NAS message container 9.4.15	M	TLV	4-253

8.5 SGsAP-EPS-DETACH-ACK message

This message is sent by the VLR to the MME to acknowledge a previous SGsAP-EPS-DETACH-INDICATION message. Table 8.5.1 shows the content of the SGsAP-EPS-DETACH-ACK message.

Table 8.5.1: SGsAP-EPS-DETACH-ACK message content

Information element	Type/Reference	Presence	Format	Length
Message type	Message type 9.2	M	V	1
IMSI	IMSI 9.4.6	M	TLV	6-10

8.6 SGsAP-EPS-DETACH-INDICATION message

This message is sent by the MME to the VLR to indicate an EPS detach performed from the UE or the MME. The type of detach is indicated in the IMSI detach from EPS service type information element. Table 8.6.1 shows the content of the SGsAP-EPS-DETACH-INDICATION message.

Table 8.6.1: SGsAP-EPS-DETACH-INDICATION message content

Information element	Type/Reference	Presence	Format	Length
Message type	Message type 9.2	M	V	1
IMSI	IMSI 9.4.6	M	TLV	6-10
MME name	MME name 9.4.13	M	TLV	57
IMSI detach from EPS service type	IMSI detach from EPS service type 9.4.7	M	TLV	3

8.7 SGsAP-IMSI-DETACH-ACK message

This message is sent by the VLR to the MME to acknowledge a previous SGsAP-IMSI-DETACH-INDICATION message. Table 8.7.1 shows the content of the SGsAP-IMSI-DETACH-ACK message.

Table 8.7.1: SGsAP-IMSI-DETACH-ACK message content

Information element	Type/Reference	Presence	Format	Length
Message type	Message type 9.2	M	V	1
IMSI	IMSI 9.4.6	M	TLV	6-10

8.8 SGsAP-IMSI-DETACH-INDICATION message

This message is sent by the MME to the VLR to indicate an IMSI detach performed from the UE. The type of detach is indicated in the IMSI detach from non-EPS service type information element. Table 8.8.1 shows the content of the SGsAP-IMSI-DETACH-INDICATION message.

Table 8.8.1: SGsAP-IMSI-DETACH-INDICATION message content

Information element	Type/Reference	Presence	Format	Length
Message type	Message type 9.2	M	V	1
IMSI	IMSI 9.4.6	M	TLV	6-10
MME name	MME name 9.4.13	M	TLV	57
IMSI Detach from non-EPS service type	IMSI detach from non-EPS service type 9.4.8	M	TLV	3

8.9 SGsAP-LOCATION-UPDATE-ACCEPT message

8.9.1 Message definition

This message is sent by the VLR to the MME to indicate that update or IMSI attach in the VLR has been completed. Table 8.9.1.1 shows the content of the SGsAP-LOCATION-UPDATE-ACCEPT message.

Table 8.9.1.1: SGsAP-LOCATION-UPDATE-ACCEPT message content

Information element	Type/Reference	Presence	Format	Length
Message type	Message type 9.2	M	V	1
IMSI	IMSI 9.4.6	M	TLV	6-10
Location area identifier	Location area identifier 9.4.11	M	TLV	7
New TMSI, or IMSI	Mobile identity 9.4.14	O	TLV	6-10

8.9.2 New TMSI, or IMSI

This information element represents the identity to be used for (and then by) the UE.

If this information element is an IMSI, then the UE is not allocated any TMSI (and deletes any TMSI accordingly). If this information element is a TMSI, then the UE will use this TMSI as the new temporary identity (the UE deletes its old TMSI and stores the new TMSI). If neither a TMSI nor an IMSI are included in this information element, the old TMSI, if any available, will be kept.

8.10 SGsAP-LOCATION-UPDATE-REJECT message

This message is sent by the VLR to the MME to indicate that location update or IMSI attach has failed. Table 8.10.1 shows the content of the SGsAP-LOCATION-UPDATE-REJECT message.

Table 8.10.1: SGsAP-LOCATION-UPDATE-REJECT message content

Information element	Type/Reference	Presence	Format	Length
Message type	Message type 9.2	M	V	1
IMSI	IMSI 9.4.6	M	TLV	6-10
Reject cause	Reject cause 9.4.16	M	TLV	3

8.11 SGsAP-LOCATION-UPDATE-REQUEST message

8.11.1 Message definition

This message is sent by the MME to the VLR either to request update of its location file (normal update) or to request IMSI attach. Table 8.11.1.1 shows the content of the SGsAP-LOCATION-UPDATE-REQUEST message.

Table 8.11.1.1: SGsAP-LOCATION-UPDATE-REQUEST message content

Information element	Type/Reference	Presence	Format	Length
Message type	Message type 9.2	M	V	1
IMSI	IMSI 9.4.6	M	TLV	6-10
MME name	MME name 9.4.13	M	TLV	57
EPS location update type	EPS location update type 9.4.2	M	TLV	3
New location area identifier	Location area identifier 9.4.11	M	TLV	7
Old location area identifier	Location area identifier 9.4.11	O	TLV	7
TMSI status	TMSI status 9.4.21	O	TLV	3
IMEISV	IMEISV 9.4.5	O	TLV	10
TAI	Tracking Area Identity 9.4.21a	O	TLV	7
E-CGI	E-UTRAN Cell Global Identity 9.4.3a	O	TLV	9

8.11.2 Old location area identifier

The MME shall include this information element if the UE included the old location area information in the ATTACH REQUEST or TRACKING AREA UPDATE REQUEST message.

8.11.3 TMSI status

The MME shall include this information element if the TMSI status received in the ATTACH REQUEST or TRACKING AREA UPDATING REQUEST message from the UE indicates that no valid TMSI is available in the UE.

8.11.4 IMEISV

The MME shall include this information element if the MME supports the "Automatic Device Detection" or the "Trace for Management Based Activation/Deactivation".

8.11.5 TAI

If the TAI is available in the MME, the MME shall include this information element.

8.11.6 E-CGI

If the E-CGI is available in the MME, the MME shall include this information element.

8.12 SGsAP-MM-INFORMATION-REQUEST

This message is sent by the VLR to the MME to provide the UE with subscriber specific information. Table 8.12.1 shows the content of the SGsAP-MM-INFORMATION-REQUEST message.

Table 8.12.1: SGsAP-MM-INFORMATION-REQUEST message content

Information element	Type/Reference	Presence	Format	Length
Message type	Message type 9.2	M	V	1
IMSI	IMSI 9.4.6	M	TLV	6-10
MM information	MM information 9.4.12	M	TLV	3-n

8.13 SGsAP-PAGING-REJECT message

This message is sent from the MME to the VLR to indicate that the delivery of a previous SGsAP-PAGING-REQUEST message has failed. Table 8.13.1 shows the content of the SGsAP-PAGING-REJECT message.

Table 8.13.1: SGsAP-PAGING-REJECT message content

Information element	Type/Reference	Presence	Format	Length
Message type	Message type 9.2	M	V	1
IMSI	IMSI 9.4.6	M	TLV	6-10
SGs Cause	SGs Cause 9.4.18	M	TLV	3

8.14 SGsAP-PAGING-REQUEST message

8.14.1 Message definition

This message is sent from the VLR to the MME and contains sufficient information to allow the paging message to be transmitted by the correct cells at the correct time. Table 8.14.1.1 shows the content of the SGsAP-PAGING-REQUEST message.

Table 8.14.1.1: SGsAP-PAGING-REQUEST message content

Information element	Type/Reference	Presence	Format	Length
Message type	Message type 9.2	M	V	1
IMSI	IMSI 9.4.6	M	TLV	6-10
VLR name	VLR name 9.4.22	M	TLV	3-n
Service indicator	Service indicator 9.4.17	M	TLV	3
TMSI	TMSI 9.4.20	O	TLV	6
CLI	CLI 9.4.1	O	TLV	3-14
Location area identifier	Location area identifier 9.4.11	O	TLV	7
Global CN-Id	Global CN-Id 9.4.4	O	TLV	7
SS code	SS code 9.4.19	O	TLV	3
LCS indicator	LCS indicator 9.4.10	O	TLV	3
LCS client identity	LCS client identity 9.4.9	O	TLV	3-n
Channel needed	Channel needed 9.4.23	O	TLV	3
eMLPP Priority	eMLPP Priority 9.4.24	O	TLV	3

8.14.2 TMSI

This element is omitted in the exceptional case where paging with IMSI is performed.

8.14.3 CLI

If the Calling Line Identification is available in the VLR, the VLR shall include this information element.

8.14.4 Location area identifier

The VLR shall include this information element if the "Confirmed by Radio Contact" restoration indicator is set to "true".

8.14.5 Global CN-Id

If the network supports the Intra Domain Connection of RAN Nodes to multiple CN Nodes functionality, the VLR shall include this information element when the VLR initiates paging by IMSI, via the SGs interface.

8.14.6 SS code

The VLR shall include this information element if paging is due to a NW-initiated Call Independent SS procedure (see 3GPP TS 24.010 [9]).

8.14.7 LCS indicator

The VLR shall include this information element if the paging is due to a Mobile Terminated Location Request (see 3GPP TS 24.030 [11]).

8.14.8 LCS client identity

The VLR shall include this information element if the paging is due to a Mobile Terminated Location Request (see 3GPP TS 24.030 [11]).

8.14.9 Channel needed

This information element shall be included if the VLR intends to indicate which channel the UE should use.

8.14.10 eMLPP priority

This information element shall be included if the subscriber has a subscription for eMLPP and the VLR intends to indicate eMLPP priority to the UE.

8.15 SGsAP-RESET-ACK message

8.15.1 Message definition

This message is sent from the MME or the VLR to acknowledge a previous SGsAP-RESET-INDICATION message. This message indicates that all the SGs associations to the VLR or the MME have been marked as invalid.

The sending entity (either MME or VLR) includes its identity in the form of a name in the SGsAP-RESET-ACK message. Table 8.15.1.1 shows the content of the SGsAP-RESET-ACK message.

Table 8.15.1.1: SGsAP-RESET-ACK message content

Information element	Type/Reference	Presence	Format	Length
Message type	Message type 9.2	M	V	1
MME name	MME name 9.4.13	C	TLV	57
VLR name	VLR name 9.4.22	C	TLV	3-n

8.15.2 MME name

If the MME is the sending entity, then the MME shall indicate its identity by including its MME name information element. Otherwise (i.e. if the VLR is the sending entity), then the VLR shall not include the MME name information element.

8.15.3 VLR name

If the VLR is the sending entity, then the VLR shall indicate its identity by including its VLR name information element. Otherwise (i.e. if the MME is the sending entity), then MME shall not include the VLR name information element.

8.16 SGsAP-RESET-INDICATION message

8.16.1 Message definition

This message is sent from the VLR to the MME to indicate that a failure in the VLR has occurred and all the SGs associations to the VLR are be marked as invalid.

This message is also sent from the MME to the VLR to indicate that a failure in the MME has occurred and all the SGs associations to the MME are be marked as invalid.

The sending entity (either MME or VLR) includes its identity in the SGsAP-RESET-INDICATION message. Table 8.16.1.1 shows the content of the SGsAP-RESET-INDICATION message.

Table 8.16.1.1: SGsAP-RESET-INDICATION message content

Information element	Type/Reference	Presence	Format	Length
Message type	Message type 9.2	M	V	1
MME name	MME name 9.4.13	C	TLV	57
VLR name	VLR name 9.4.22	C	TLV	3-n

8.16.2 MME name

If the MME is the sending entity, then the MME shall indicate its identity by including its MME name information element. Otherwise (i.e. if the VLR is the sending entity), then the VLR shall not include the MME name information element.

8.16.3 VLR name

If the VLR is the sending entity, then the VLR shall indicate its identity by including its VLR name information element. Otherwise (i.e. if the MME is the sending entity), then the MME shall not include the VLR name information element.

8.17 SGsAP-SERVICE-REQUEST message

8.17.1 Message definition

This message is sent from the MME to the VLR as a response to a previously received SGsAP-PAGING-REQUEST message to indicate the existence of a NAS signalling connection between the UE and the MME or to indicate to the VLR that the NAS signalling connection has been established after the paging procedure for SMS. Table 8.17.1 shows the content of the SGsAP-SERVICE-REQUEST message.

Table 8.17.1: SGsAP-SERVICE-REQUEST message content

Information element	Type/Reference	Presence	Format	Length
Message type	Message type 9.1	M	V	1
IMSI	IMSI 9.4.6	M	TLV	6-10
Service indicator	Service indicator 9.4.17	M	TLV	3
IMEISV	IMEISV 9.4.5	O	TLV	10
UE Time Zone	UE Time Zone 9.4.21b	O	TLV	3
Mobile Station Classmark 2	Mobile Station Classmark 2 9.4.14a	O	TLV	5
TAI	Tracking Area Identity 9.4.21a	O	TLV	7
E-CGI	E-UTRAN Cell Global Identity 9.4.3a	O	TLV	9
UE EMM Mode	UE EMM mode 9.4.21c	O	TLV	3

8.17.2 IMEISV

If the IMEISV is available in the MME, the MME shall include this information element.

8.17.3 UE Time Zone

If the UE Time Zone is available in the MME, the MME shall include this information element.

8.17.4 Mobile Station Classmark 2

If the Mobile Station Classmark 2 is available in the MME, the MME shall include this information element.

8.17.5 TAI

If the TAI is available in the MME, the MME shall include this information element.

8.17.6 E-CGI

If the E-CGI is available in the MME, the MME shall include this information element.

8.17.7 UE EMM Mode

The MME shall include this information element. This information element indicates the EMM mode of the UE when the SGsAP-PAGING-REQUEST message was received by the MME.

8.18 SGsAP-STATUS message

8.18.1 Message definition

This message is sent by both the VLR and the MME to indicate an error. The contents of SGsAP-STATUS message are shown in table 8.18.1.1.

Table 8.18.1.1: SGsAP-STATUS message content

Information element	Type/Reference	Presence	Format	Length
Message type	Message type 9.2	M	V	1
IMSI	IMSI 9.4.6	O	TLV	6-10
SGs cause	SGs cause 9.4.18	M	TLV	3
Erroneous message	Erroneous message 9.4.3	M	TLV	3-n

8.18.2 IMSI

The MME shall include this information element if the IMSI is present in the erroneous message.

8.19 SGsAP-TMSI-REALLOCATION-COMPLETE message

This message is sent by the MME to the VLR to indicate that TMSI reallocation on the UE has been successfully completed. Table 8.19.1 shows the content of the SGsAP-TMSI-REALLOCATION-COMPLETE message.

Table 8.19.1: SGsAP-TMSI-REALLOCATION-COMPLETE message content

Information element	Type/Reference	Presence	Format	Length
Message type	Message type 9.2	M	V	1
IMSI	IMSI 9.4.6	M	TLV	6-10

8.20 SGsAP-UE-ACTIVITY-INDICATION message

This message is sent by the MME to the VLR to indicate that activity from a UE has been detected. Table 8.20.1 shows the content of the SGsAP-UE-ACTIVITY-INDICATION message.

Table 8.20.1: SGsAP-UE-ACTIVITY-INDICATION message content

Information element	Type/Reference	Presence	Format	Length
Message type	Message type 9.2	M	V	1
IMSI	IMSI 9.4.6	M	TLV	6-10

8.21 SGsAP-UE-UNREACHABLE message

This message is sent from the MME to the VLR to indicate that, for example, paging could not be performed because the UE is marked as unreachable at the MME. Table 8.21.1 shows the content of the SGsAP-UE-UNREACHABLE message.

Table 8.21.1: SGsAP-UE-UNREACHABLE message content

Information element	Type/Reference	Presence	Format	Length
Message type	Message type 9.2	M	V	1
IMSI	IMSI 9.4.6	M	TLV	6-10
SGs cause	SGs cause 9.4.18	M	TLV	3

8.22 SGsAP-UPLINK-UNITDATA message

8.22.1 Message definition

This message is sent from the MME to the VLR to transparently convey a NAS message, from the UE, to the VLR. Table 8.22.1 shows the content of the SGsAP-UPLINK-UNITDATA message.

Table 8.22.1: SGsAP-UPLINK-UNITDATA message content

Information element	Type/Reference	Presence	Format	Length
Message type	Message type 9.2	M	V	1
IMSI	IMSI 9.4.6	M	TLV	6-10
NAS message container	NAS message container 9.4.15	M	TLV	4-253
IMEISV	IMEISV 9.4.5	O	TLV	10
UE Time Zone	UE Time Zone 9.4.21b	O	TLV	3
Mobile Station Classmark 2	Mobile Station Classmark 2 9.4.14a	O	TLV	5
TAI	Tracking Area Identity 9.4.21a	O	TLV	7
E-CGI	E-UTRAN Cell Global Identity 9.4.3a	O	TLV	9

8.22.2 IMEISV

If the IMEISV is available in the MME, the MME shall include this information element.

8.22.3 UE Time Zone

If the UE Time Zone is available in the MME, the MME shall include this information element.

8.22.4 Mobile Station Classmark 2

If the Mobile Station Classmark 2 is available in the MME, the MME shall include this information element.

8.22.5 TAI

If the TAI is available in the MME, the MME shall include this information element.

8.22.6 E-CGI

If the E-CGI is available in the MME, the MME shall include this information element.

8.23 SGsAP-RELEASE-REQUEST message

This message is sent by the VLR to the MME when the VLR determines that there are no more NAS messages to be exchanged between the VLR and the UE. Table 8.23.1 shows the content of the SGsAP-RELEASE-REQUEST message.

Table 8.23.1: SGsAP-RELEASE-REQUEST message content

Information element	Type/Reference	Presence	Format	Length
Message type	Message type 9.2	M	V	1
IMSI	IMSI 9.4.6	M	TLV	6-10

9 Information element coding

9.1 Overview

This clause specifies the coding of the information elements used in by the SGsAP protocol.

The spare bits in the coding of an information element shall be set to zero by the sender and shall be ignored by the receiver.

All unassigned codes (whether omitted or explicitly *Unassigned* in the text) shall be treated as unknown (see clause 7).

9.2 Message type

Message type uniquely identifies the message being sent. It is a single octet information element, mandatory in all messages. Table 9.2.1 defines the value part of the Message type information element.

Table 9.2.1: Message type information element

8 7 6 5 4 3 2 1	Message type	Reference
0 0 0 0 0 0 0 0	Unassigned: treated as an unknown Message type	7
0 0 0 0 0 0 0 1	SGsAP-PAGING-REQUEST	8.14
0 0 0 0 0 0 1 0	SGsAP-PAGING-REJECT	8.13
0 0 0 0 0 0 1 1 to 0 0 0 0 0 1 0 1	Unassigned: treated as an unknown Message type	7
0 0 0 0 0 1 1 0	SGsAP-SERVICE-REQUEST	8.17
0 0 0 0 0 1 1 1	SGsAP-DOWNLINK-UNITDATA	8.4
0 0 0 0 1 0 0 0	SGsAP-UPLINK-UNITDATA	8.22
0 0 0 0 1 0 0 1	SGsAP-LOCATION-UPDATE-REQUEST	8.11
0 0 0 0 1 0 1 0	SGsAP-LOCATION-UPDATE-ACCEPT	8.9
0 0 0 0 1 0 1 1	SGsAP-LOCATION-UPDATE-REJECT	8.10
0 0 0 0 1 1 0 0	SGsAP-TMSI-REALLOCATION-COMPLETE	8.19
0 0 0 0 1 1 0 1	SGsAP-ALERT-REQUEST	8.3
0 0 0 0 1 1 1 0	SGsAP-ALERT-ACK	8.1
0 0 0 0 1 1 1 1	SGsAP-ALERT-REJECT	8.2
0 0 0 1 0 0 0 0	SGsAP-UE-ACTIVITY-INDICATION	8.20
0 0 0 1 0 0 0 1	SGsAP-EPS-DETACH-INDICATION	8.6
0 0 0 1 0 0 1 0	SGsAP-EPS-DETACH-ACK	8.5
0 0 0 1 0 0 1 1	SGsAP-IMSI-DETACH-INDICATION	8.8
0 0 0 1 0 1 0 0	SGsAP-IMSI-DETACH-ACK	8.7
0 0 0 1 0 1 0 1	SGsAP-RESET-INDICATION	8.16
0 0 0 1 0 1 1 0	SGsAP-RESET-ACK	8.15
0 0 0 1 0 1 1 1 to 0 0 0 1 1 0 0 1	Unassigned: treated as an unknown Message type	7
0 0 0 1 1 0 1 0	SGsAP-MM-INFORMATION-REQUEST	8.12
0 0 0 1 1 0 1 1	SGsAP-RELEASE-REQUEST	8.23
0 0 0 1 1 1 0 0	Unassigned: treated as an unknown Message type	7
0 0 0 1 1 1 0 1	SGsAP-STATUS	8.18
0 0 0 1 1 1 1 0	Unassigned: treated as an unknown Message type	7
0 0 0 1 1 1 1 1	SGsAP-UE-UNREACHABLE	8.21

9.3 Information element identifiers

The next list shows the coding of the information element identifiers used in the present document. Table 9.3.1 shows the values assigned for the information element identifiers.

Table 9.3.1: Information element identifier coding

8 7 6 5 4 3 2 1	Information element	Reference
0 0 0 0 0 0 0 1	IMSI	9.4.6
0 0 0 0 0 0 1 0	VLR name	9.4.22
0 0 0 0 0 0 1 1	TMSI	9.4.20
0 0 0 0 0 1 0 0	Location area identifier	9.4.11
0 0 0 0 0 1 0 1	Channel Needed	9.4.23
0 0 0 0 0 1 1 0	eMLPP Priority	9.4.24
0 0 0 0 0 1 1 1	TMSI status	9.4.21
0 0 0 0 1 0 0 0	SGs cause	9.4.18
0 0 0 0 1 0 0 1	MME name	9.4.13
0 0 0 0 1 0 1 0	EPS location update type	9.4.2
0 0 0 0 1 0 1 1	Global CN-Id	9.4.4
0 0 0 0 1 1 1 0	Mobile identity	9.4.14
0 0 0 0 1 1 1 1	Reject cause	9.4.16
0 0 0 1 0 0 0 0	IMSI detach from EPS service type	9.4.7
0 0 0 1 0 0 0 1	IMSI detach from non-EPS service type	9.4.8
0 0 0 1 0 1 0 1	IMEISV	9.4.5
0 0 0 1 0 1 1 0	NAS message container	9.4.15
0 0 0 1 0 1 1 1	MM information	9.4.12
0 0 0 1 1 0 1 1	Erroneous message	9.4.3
0 0 0 1 1 1 0 0	CLI	9.4.1
0 0 0 1 1 1 0 1	LCS client identity	9.4.9
0 0 0 1 1 1 1 0	LCS indicator	9.4.10
0 0 0 1 1 1 1 1	SS code	9.4.19
0 0 1 0 0 0 0 0	Service indicator	9.4.17
0 0 1 0 0 0 0 1	UE Time Zone	9.4.21b
0 0 1 0 0 0 1 0	Mobile Station Classmark 2	9.4.14a
0 0 1 0 0 0 1 1	Tracking Area Identity	9.4.21a
0 0 1 0 0 1 0 0	E-UTRAN Cell Global Identity	9.4.3a
0 0 1 0 0 1 0 1	UE EMM mode	9.4.21c

9.4 Information elements

9.4.1 CLI

This information element is used to represent calling line identification for the terminating call received in the CS domain. The CLI information element is coded as shown in figure 9.4.1.1.

	8	7	6	5	4	3	2	1
Octet 1	IEI							
Octet 2	Length indicator							
Octet 3 To Octet 14	Octets 3 to 14 contain the value part of the Calling party BCD number information element defined in subclause 10.5.4.9 of 3GPP TS 24.008 [8] (octets 3 to 14, i.e. not including 3GPP TS 24.008 IEI and 3GPP TS 24.008 length indicator)							

Figure 9.4.1.1: Calling Line Identification information element

9.4.2 EPS location update type

The purpose of the EPS location update type information element is to indicate to the VLR whether an IMSI attach or a normal location update has been performed by the UE. The EPS location update type information element is coded as shown in figure 9.4.2.1 and table 9.4.2.1.

	8	7	6	5	4	3	2	1
Octet 1	IEI							
Octet 2	Length indicator							
Octet 3	EPS location update type value							

Figure 9.4.2.1: EPS location update type information element

Table 9.4.2.1: EPS location update type information element value part

EPS location update type value (octet 3)	
Bits	
8 7 6 5 4 3 2 1	
0 0 0 0 0 0 0 0	Shall not be sent in this version of the protocol. If received, shall be treated as '00000010'
0 0 0 0 0 0 0 1	IMSI attach
0 0 0 0 0 0 1 0	Normal location update
0 0 0 0 0 0 1 1	
to	Shall not be sent in this version of the protocol. If received, shall be treated as '00000010'
1 1 1 1 1 1 1 1	

9.4.3 Erroneous message

See subclause 18.4.5 in 3GPP TS 29.018 [16].

9.4.3a E-UTRAN Cell Global Identity

The E-UTRAN Cell Global Identity information element indicates the UE's current E-UTRAN Cell Global Identity. The E-UTRAN Cell Global Identity information element is coded as shown in figure 9.4.3a.1.

	8	7	6	5	4	3	2	1
Octet 1	IEI							
Octet 2	Length indicator							
Octet 3	The coding of the E-UTRAN Cell Global Identity value is according to ECGL field information element as specified in subclause 8.21.5 of 3GPP TS 29.274 [17A]							
Octet 9								

Figure 9.4.3a.1: E-UTRAN Cell Global Identity information element

9.4.4 Global CN-Id

See subclause 18.4.27 in 3GPP TS 29.018 [16].

9.4.5 IMEISV

See subclause 18.4.9 in 3GPP TS 29.018 [16].

9.4.6 IMSI

See subclause 18.4.10 in 3GPP TS 29.018 [16].

9.4.7 IMSI detach from EPS service type

The IMSI detach from EPS service type information element indicates from MME to VLR the particular type of IMSI detach from EPS. The IMSI detach from EPS service type information element is coded as shown in figure 9.4.7.1 and table 9.4.7.1.

	8	7	6	5	4	3	2	1
Octet 1	IEI							
Octet 2	Length indicator							
Octet 3	IMSI detach from EPS service type value							

Figure 9.4.7.1: IMSI detach from EPS service type information element

Table 9.4.7.1: IMSI detach from EPS service type information element value

IMSI detach from EPS service type value (octet 3)	
Bits	
8 7 6 5 4 3 2 1	
0 0 0 0 0 0 0 0	Interpreted as reserved in this version of the protocol
0 0 0 0 0 0 0 1	Network initiated IMSI detach from EPS services
0 0 0 0 0 0 1 0	UE initiated IMSI detach from EPS services
0 0 0 0 0 0 1 1	EPS services not allowed
0 0 0 0 0 1 0 0	
to	Interpreted as reserved in this version of the protocol
1 1 1 1 1 1 1 1	

9.4.8 IMSI detach from non-EPS service type

The IMSI detach from non-EPS service type information element indicates from MME to VLR the particular type of IMSI detach from non-EPS. The IMSI detach from non-EPS service type information element is coded as shown in figure 9.4.8.1 and table 9.4.8.1.

	8	7	6	5	4	3	2	1
Octet 1	IEI							
Octet 2	Length indicator							
Octet 3	IMSI detach from non-EPS service type value							

Figure 9.4.8.1: IMSI detach from non-EPS service type information element

Table 9.4.8.1: IMSI detach from non-EPS service type information element value

IMSI detach from non-EPS service type value (octet 3)	
Bits	
8 7 6 5 4 3 2 1	
0 0 0 0 0 0 0 0	Interpreted as reserved in this version of the protocol
0 0 0 0 0 0 0 1	Explicit UE initiated IMSI detach from non-EPS services
0 0 0 0 0 0 1 0	Combined UE initiated IMSI detach from EPS and non-EPS services
0 0 0 0 0 0 1 1	Implicit network initiated IMSI detach from non-EPS services
0 0 0 0 0 1 0 0	
to	Interpreted as reserved in this version of the protocol
1 1 1 1 1 1 1 1	

9.4.9 LCS client identity

The LCS client identity information element is a compound parameter and comprises information related to the client of a LCS request. The LCS client identity information element is coded as shown in figure 9.4.9.1.

	8	7	6	5	4	3	2	1
Octet 1	IEI							
Octet 2	Length indicator							
Octet 3 to Octet n	The coding of the LCS client identity value is according to LCS-ClientID as specified in subclause 17.7.13 of 3GPP TS 29.002 [15]							

Figure 9.4.9.1: LCS client identity information element

9.4.10 LCS indicator

The LCS indicator information element indicates that the origin of the message is due to a LCS request and the type of this request. The LCS indicator information element is coded as shown in figure 9.4.10.1 and table 9.4.10.1.

	8	7	6	5	4	3	2	1
Octet 1	IEI							
Octet 2	Length indicator							
Octet 3	LCS indicator value							

Figure 9.4.10.1: LCS indicator information element

Table 9.4.10.1: LCS indicator value

LCS indicator	
Bits	
8 7 6 5 4 3 2 1	
0 0 0 0 0 0 0 0	Normal, unspecified in this version of the protocol.
0 0 0 0 0 0 0 1	MT-LR
0 0 0 0 0 0 1 0	
to	Normal, unspecified in this version of the protocol
1 1 1 1 1 1 1 1	

9.4.11 Location area identifier

This element uniquely identifies one Location Area. The Location area identifier information element is coded as shown in figure 9.4.11.1.

	8	7	6	5	4	3	2	1
Octet 1	IEI							
Octet 2	Length Indicator							
Octet 3 - Octet 7	Octets 3 to 7 contain the value part of the Location area identification information element defined in 3GPP TS 24.008 [8] (starting with octet 2, i.e. not including 3GPP TS 24.008 IEI)							

Figure 9.4.11.1: Location area identifier information element

9.4.12 MM information

The MM information information element is a TLV information element that encapsulates the user information that the MME forwards to the UE. For the coding see subclause 18.4.16 in 3GPP TS 29.018 [16].

9.4.13 MME name

The MME name information element specifies the MME name and is coded as shown in figure 9.4.13.1. Octets 3 through n contain the name in the form of a fully qualified domain name (FQDN) as specified in 3GPP TS 23.003 [3]. The value part of the MME name information element (not including IEI and length indicator) shall have a length of 55 octets.

	8	7	6	5	4	3	2	1
Octet 1	IEI							
Octet 2	Length Indicator							
Octet 3	MME name (leftmost character of FQDN)							
-	-							
Octet n	MME name (rightmost character of FQDN)							

Figure 9.4.13.1: MME name information element

9.4.14 Mobile identity

See subclause 18.4.17 in 3GPP TS 29.018 [16].

9.4.14a Mobile Station Classmark 2

With the exception of the IEI, the contents are specified in subclause 10.5.1.6 in 3GPP TS 24.008 [8].

9.4.15 NAS message container

This information element is used to encapsulate the SMS messages transferred between the VLR and the MME. The NAS message container information element is coded as shown in figure 9.4.15.1.

	8	7	6	5	4	3	2	1
Octet 1	IEI							
Octet 2	Length indicator							
Octet 3 to Octet 253	Octets 3 to 253 contain the SMS message (i.e. CP-DATA, CP-ACK or CP-ERROR) as defined in subclause 7.2 of 3GPP TS 24.011 [10]							

Figure 9.4.15.1: NAS message container information element

9.4.16 Reject cause

See subclause 18.4.21 in 3GPP TS 29.018 [16].

9.4.17 Service indicator

This information element indicates the type of the CS service (e.g. voice call, Short Message Service). The Service indicator information element is coded as shown in figure 9.4.17.1 and table 9.4.17.1.

	8	7	6	5	4	3	2	1
Octet 1	IEI							
Octet 2	Length indicator							
Octet 3	Service indicator value							

Figure 9.4.17.1: Service indicator information element

Table 9.4.17.1: Service indicator value

Service indicator	
Bits	
8 7 6 5 4 3 2 1	
0 0 0 0 0 0 0 0	Shall not be sent in this version of the protocol. If received, shall be treated as '00000001'
0 0 0 0 0 0 0 1	CS call indicator
0 0 0 0 0 0 1 0	SMS indicator
0 0 0 0 0 0 1 1	
to	Shall not be sent in this version of the protocol. If received, shall be treated as '00000001'
1 1 1 1 1 1 1 1	

9.4.18 SGs cause

The purpose of the SGs cause information element is to indicate an error to the receiving entity. This could be a protocol data error, to indicate to the VLR the reason why a paging procedure could not be performed or to indicate to the VLR that the mobile terminating CS fallback call has been rejected by the user. The SGs cause information element is coded as shown in figure 9.4.18.1 and table 9.4.18.1.

	8	7	6	5	4	3	2	1
Octet 1	IEI							
Octet 2	Length indicator							
Octet 3	SGs cause value							

Figure 9.4.18.1: SGs cause information element

Table 9.4.18.1: SGs cause information element value part

SGs cause value (octet 3)	
Bits	
8 7 6 5 4 3 2 1	
0 0 0 0 0 0 0 0	Normal, unspecified in this version of the protocol.
0 0 0 0 0 0 0 1	IMSI detached for EPS services
0 0 0 0 0 0 1 0	IMSI detached for EPS and non-EPS services
0 0 0 0 0 0 1 1	IMSI unknown
0 0 0 0 0 1 0 0	IMSI detached for non-EPS services
0 0 0 0 0 1 0 1	IMSI implicitly detached for non-EPS services
0 0 0 0 0 1 1 0	UE unreachable
0 0 0 0 0 1 1 1	Message not compatible with the protocol state
0 0 0 0 1 0 0 0	Missing mandatory information element
0 0 0 0 1 0 0 1	Invalid mandatory information
0 0 0 0 1 0 1 0	Conditional information element error
0 0 0 0 1 0 1 1	Semantically incorrect message
0 0 0 0 1 1 0 0	Message unknown
0 0 0 0 1 1 0 1	Mobile terminating CS fallback call rejected by the user
0 0 0 0 1 1 1 0	
to	Normal, unspecified in this version of the protocol
1 1 1 1 1 1 1 1	

NOTE: "Normal, unspecified" has the same meaning than in 3GPP TS 24.008 [8], informative Annex H (UMTS specific cause values for call control). It is used to report a normal event, and should not be interpreted as syntactically incorrect nor unknown if received.

9.4.19 SS code

The SS code information element is used to represent the code identifying a single supplementary service, a group of supplementary services, or all supplementary services. The SS code information element is coded as shown in figure 9.4.19.1.

	8	7	6	5	4	3	2	1
Octet 1	IEI							
Octet 2	Length indicator							
Octet 3	The coding of the SS code value is according to SS-Code as specified in subclause 17.7.5 of 3GPP TS 29.002 [15]							

Figure 9.4.19.1: SS code information element

9.4.20 TMSI

See subclause 18.4.23 in 3GPP TS 29.018 [16].

9.4.21 TMSI status

See subclause 18.4.24 in 3GPP TS 29.018 [16].

9.4.21a Tracking Area Identity

This element uniquely identifies one Tracking Area. The Tracking Area Identity information element is coded as shown in figure 9.4.21a.1.

	8	7	6	5	4	3	2	1
Octet 1	IEI							
Octet 2	Length indicator							
Octet 3 -	Octets 3 to 7 contain the value part of the Tracking Area Identity information element defined in 3GPP TS 24.301 [14] (starting with octet 2, i.e. not including 3GPP TS 24.301 IEI)							
Octet 7								

Figure 9.4.21a.1: Tracking Area Identity information element

9.4.21b UE Time Zone

This element identifies the offset between universal time and local time in steps of 15 minutes. The UE Time Zone information element is coded as shown in figure 9.4.21b.1.

	8	7	6	5	4	3	2	1
Octet 1	IEI							
Octet 2	Length indicator							
Octet 3	The coding of the UE Time Zone value is according to value part of the Time Zone information element as specified in subclause 10.5.3.8 of 3GPP TS 24.008 [8] (i.e. not including 3GPP TS 24.008 IEI)							

Figure 9.4.21b.1: UE Time Zone information element

9.4.21c UE EMM mode

The UE EMM mode information element is used by MME to indicate to the VLR the EMM mode of the UE upon reception of the SGsAP-PAGING-REQUEST message. The UE EMM mode information element is coded as shown in figure 9.4.21c.1 and table 9.4.21c.1.

	8	7	6	5	4	3	2	1
Octet 1	IEI							
Octet 2	Length indicator							
Octet 3	UE EMM mode value							

Figure 9.4.21c.1: UE EMM mode information element

Table 9.4.21c.1: UE EMM mode value

UE EMM mode value (octet 3)	
Bits	
8 7 6 5 4 3 2 1	
0 0 0 0 0 0 0 0	EMM-IDLE
0 0 0 0 0 0 0 1	EMM-CONNECTED
0 0 0 0 0 0 1 0	Interpreted as reserved in this version of the protocol
to	
1 1 1 1 1 1 1 1	

9.4.22 VLR name

The VLR name information element specifies the VLR name and is coded as shown in figure 9.4.22.1. Octets 3 through n contain the VLR name in the form of a fully qualified domain name (FQDN) as specified in IETF RFC 1035 [21]. The VLR name is locally configured in the MME.

	8	7	6	5	4	3	2	1
Octet 1	IEI							
Octet 2	Length Indicator							
Octet 3	VLR name (leftmost character of FQDN)							
-	-							
Octet n	VLR name (rightmost character of FQDN)							

Figure 9.4.22.1: VLR name information element

9.4.23 Channel needed

See subclause 18.4.2 in 3GPP TS 29.018 [16].

9.4.24 eMLPP priority

See subclause 18.4.4 in 3GPP TS 29.018 [16].

10 List of system variables

10.1 Timers

This subclause lists the management timers specified for the operation of the SGsAP protocol. All the implementation shall support the range of values specified in table 10.1.1 or table 10.1.2 as appropriate. The specific value of the timers is under the control of the operator.

Table 10.1.1: Management timers – MME side

Timer name	Default value	Timer range	Granularity	Notes	Relation to other timers
Ts6-1	-	10 s to 90 s	1 s	Guards the Location Update procedure.	It is expected to take a value greater than 2 times the maximum transmission time in the SGs interface, plus the supervision timer of the Update Location procedure (as defined in 3GPP TS 29.002 [15])
Ts8	4 s	1s to 30 s	1 s	Guards the Explicit IMSI detach from EPS services procedure.	None.
Ts9	4 s	1-30 s	1 s	Guards the Explicit IMSI detach from non-EPS services procedure.	None.
Ts10	4 s	1-30 s	1 s	Guards the Implicit IMSI detach from non-EPS services procedure.	None.
Ts12-1	-	8 - 60x384+8 s	1 min	Controls the resetting of the 'MME-Reset' variable.	It is expected to take a value greater than the longest periodic tracking area update timer running on the MME, plus the transmission delay on the radio interface.
Ts12-2	4 s	1-120 s	1 s	Guards the MME reset procedure. There is one Ts12-2 timer per VLR for which the MME has a SGs association.	None.

NOTE: The Default value is the recommended value.

Table 10.1.2: Management timers – VLR side

Timer name	Default value	Timer range	Granularity	Notes	Relation to other timers
Ts5	-	2 s to 20 s	100 ms	Guards the Paging procedure at the VLR.	Value is correlated to paging cycle. The default is set according to maximum paging cycle supported by the MME (operator choice) as defined in 3GPP TS 36.331 [19].
Ts6-2	40 s	5 s to 60 s	1 s	Guards the TMSI reallocation procedure.	It is expected to take a value greater than 2 times the maximum transmission time in the SGs interface, plus 4 times T3450 (as defined in 3GPP TS 24.301 [14])
Ts7	4 s	1 s to 30 s	1 s	Guards the Non-EPS alert procedure.	None.
Ts11	4 s	1-120 s	1 s	Guards the VLR reset procedure. There is one Ts11 timer per MME for which the VLR has a SGs association.	None.

NOTE: The Default value is the recommended value.

10.2 Retry counters

This subclause lists the management retry counters specified for the operation of the SGsAP protocol. The values in table 10.2.1 and table 10.2.2 are recommended values.

Table 10.2.1: Management retry counters – VLR side

Retry counter name	Retry value
Ns7	2
Ns11	2

Table 10.2.2: Management retry counters – MME side

Retry counter name	Retry value
Ns8	2
Ns9	2
Ns10	2
Ns12	2

Annex A (informative): Change history

Change history							
Date	TSG #	TSG Doc.	CR	Rev	Subject/Comment	Old	New
2008-06					Draft skeleton provided by rapporteur.	-	0.0.0
2008-06	CT1#54				Includes the following contributions agreed by CT1: C1-082435, C1-082710	0.0.0	0.1.0
2008-08	CT1#55				Includes the following contributions agreed by CT1: C1-083518, C1-083519, C1-083520, C1-083521, C1-083523, C1-083586	0.1.0	0.2.0
2008-09	e-mail review				Added newly assigned TS number and updated title and scope for correct definition of VLR acronym.	0.2.0	0.2.1
2008-10	CT1#55 bis				Includes the following contributions agreed by CT1: C1-083821, C1-083822, C1-083824, C1-084195, C1-084199, C1-084300, C1-084301, C1-084302, C1-084303, C1-084304, C1-084305, C1-084306, C1-084307, C1-084312, C1-084314, C1-084483, C1-084485, C1-084486, C1-084487, C1-084488	0.2.1	0.3.0
2008-11	CT1#56				Includes the following contributions agreed by CT1: C1-084709, C1-084719, C1-084722, C1-085182, C1-085194, C1-085195, C1-085196, C1-085197, C1-085301, C1-085302, C1-085303, C1-085311, C1-085522 Changes by the rapporteur: - correction of title for 3GPP TS 22.101 and 3GPP TS 32.422 in references subclause - information element identifiers for LCS client identity, LCS indicator, MM information and SS code added to table 9.3.1 - details for coding of LCS client identity moved to figure 9.4.9.1 and details for coding of SS code moved to figure 9.4.19.1 - editorial corrections to align with drafting rules	0.3.0	0.4.0
2008-11					Version 1.0.0 created for presentation to CT#42 for information and approval	0.4.0	1.0.0
2008-12	CT#42				Version 8.0.0 created after approval in CT#42	1.0.0	8.0.0
2009-03	CT#43	CP-090154	0001	2	Handle of CSFB paging procedure when UE is in connected mode	8.0.0	8.1.0
2009-03	CT#43	CP-090154	0002		SGs paging with access control in E-UTRAN	8.0.0	8.1.0
2009-03	CT#43	CP-090154	0003	2	Clarifications of paging procedure in MME	8.0.0	8.1.0
2009-03	CT#43	CP-090154	0004	1	Consistent usage of HSS	8.0.0	8.1.0
2009-03	CT#43	CP-090154	0005		Location update for non-EPS services procedure: failure and abnormal cases	8.0.0	8.1.0
2009-03	CT#43	CP-090154	0006	1	Clarifications for MM information procedure	8.0.0	8.1.0
2009-03	CT#43	CP-090154	0007	1	VLR number derivation	8.0.0	8.1.0
2009-03	CT#43	CP-090154	0008	3	Abnormal conditions for UL and DL Unitdata procedures	8.0.0	8.1.0
2009-03	CT#43	CP-090154	0009	1	MME behaviour when receiving paging for SMS	8.0.0	8.1.0
2009-03	CT#43	CP-090154	0010	1	Adding IE details	8.0.0	8.1.0
2009-03	CT#43	CP-090154	0011	2	Corrections in state models for VLR/MME	8.0.0	8.1.0
2009-03	CT#43	CP-090154	0012	2	SS handling details in VLR	8.0.0	8.1.0
2009-03	CT#43	CP-090154	0013	2	IE of paging request	8.0.0	8.1.0
2009-03	CT#43	CP-090154	0014	1	Corrections and additions for procedures for SMS delivery over SGs	8.0.0	8.1.0
2009-06	CT#44	CP-090421	0017		Removing Editor's note on EPS location update type	8.1.0	8.2.0
2009-06	CT#44	CP-090421	0019	1	Correction of the location update initiation	8.1.0	8.2.0
2009-06	CT#44	CP-090421	0021	1	Paging Procedure when MME restarts	8.1.0	8.2.0
2009-06	CT#44	CP-090421	0022		Forward of CS paging to the SGSN when ISR is activated	8.1.0	8.2.0
2009-09	CT#45	CP-090674	0023		Correction to the Location update for non-EPS services procedure in the MME	8.2.0	8.3.0
2009-09	CT#45	CP-090674	0024	1	Support multiple SCTP associations	8.2.0	8.3.0
2009-09	CT#45	CP-090674	0025		Port number and payload protocol identifier for SGsAP	8.2.0	8.3.0
2009-09	CT#45	CP-090674	0026		The usage of timer Ns12	8.2.0	8.3.0
2009-09	CT#45	CP-090674	0027		Corrections for the length of IE	8.2.0	8.3.0
2009-09	CT#45	CP-090674	0028	2	Clarification of Location Update	8.2.0	8.3.0
2009-09	CT#45	CP-090675	0029	2	Update for "SMS-only" behaviour	8.2.0	8.3.0
2009-09	CT#45	CP-090674	0031	2	Clarify the condition for starting the location update for non-EPS services procedure	8.2.0	8.3.0
2009-09	CT#45	CP-090675	0033	1	SMS over SGs charging and authority enquiry parameters	8.2.0	8.3.0
2009-09	CT#46	CP-090916	0036	1	Paging procedure in MME for supporting SMS only	8.3.0	8.4.0
2009-09	CT#46	CP-090916	0037	1	Location update initiation for SMS over SGs only	8.3.0	8.4.0
2009-09	CT#46	CP-090915	0038	6	Corrections for SGs Service Request	8.3.0	8.4.0

2009-09	CT#46	CP-090916	0039	2	Correction for Online and offline charging parameters	8.3.0	8.4.0
2009-09	CT#46	CP-090915	0040	1	Correction of definition of MME name	8.3.0	8.4.0
2009-09	CT#46	CP-090915	0041	1	Implicit detach procedure in VLR correction	8.3.0	8.4.0
2009-09	CT#46	CP-090916	0042		Remove use case of UE not supporting combined attach for "SMS only"	8.3.0	8.4.0
2009-09	CT#46	CP-090915	0043	1	Handling of EPS detach indication	8.3.0	8.4.0
2009-09	CT#46	CP-090915	0044		Correction of reference to TS 23.195	8.3.0	8.4.0
2009-09	CT#46	CP-090915	0046		MME executing the HSS location updating procedure and location update procedure for non-EPS services	8.3.0	8.4.0
2009-09	CT#46	CP-090915	0047	1	Correction of values of IMSI detach from EPS service type IE and IMSI detach from non-EPS service type IE	8.3.0	8.4.0
2009-09	CT#46	CP-090922	0034	1	Paging signalling optimization after MME failure	8.4.0	9.0.0
2009-09	CT#46	CP-090922	0035	2	Paging clarifications	8.4.0	9.0.0
2009-09	CT#46	CP-090922	0048	1	Add UE EMM Mode IE in SGsAP-SERVICE-REQUEST message	8.4.0	9.0.0
2010-03	CT#47	CP-100126	0049	2	MME Name octet length correction	9.0.0	9.1.0
2010-03	CT#47	CP-100126	0052		Alignment term "CSFB and SMS over SGs" with TS23.401 (Part III)	9.0.0	9.1.0
2010-03	CT#47	CP-100134	0053	2	Modification of the paging procedure	9.0.0	9.1.0
2010-03	CT#47	CP-100126	0056		Clarification of paging procedure for SMS	9.0.0	9.1.0
2010-03	CT#47	CP-100126	0058	1	Paging for SMS on S3 and no paging retransmission in the MME	9.0.0	9.1.0
2010-06	CT#48	CP-100348	0065	2	Alert MME Notification / UE Activity Notification procedure on S3 interface	9.1.0	9.2.0
2010-06	CT#48	CP-100348	0069	3	Paging Procedures in the MME for SMS Service Type	9.1.0	9.2.0
2010-06	CT#48	CP-100348	0072		Removal of reference to TS 23.195	9.1.0	9.2.0
2010-06	CT#48	CP-100354	0074	1	New LAI derivation at MME	9.1.0	9.2.0
2010-09	CT#49	CP-100501	0085	2	Correction to LAI derivation for default SGs scenario	9.2.0	9.3.0
2010-09	CT#49	CP-100495	0090	1	IMSI detach from EPS and Non-EPS services	9.2.0	9.3.0
2010-12	CT#50	CP-100742	0113	3	CS PLMN determination for CSFB	9.3.0	9.4.0
2010-12	CT#50	CP-100740	0121	1	Paging failure on SGs	9.3.0	9.4.0
2010-12	CT#50	CP-100740	0135		Removal of VLR number derivation by the MME	9.3.0	9.4.0
2011-06	CT#52	CP-110457	0161	1	Removal of CS PLMN reselection requirement for CSFB	9.4.0	9.5.0
2011-12	CT#54	CP-110858	0191	1	Inclusion of E-UTRAN location in SGs Location Update message	9.5.0	9.6.0
2011-12	CT#54	CP-110940	0188	5	Provide Subscriber Information handling for UE under LTE	9.5.0	9.6.0

History

Document history		
V9.0.0	January 2010	Publication
V9.1.0	April 2010	Publication
V9.2.0	June 2010	Publication
V9.3.0	October 2010	Publication
V9.4.0	January 2011	Publication
V9.5.0	June 2011	Publication
V9.6.0	January 2012	Publication