

ETSI TS 129 207 V6.3.0 (2005-03)

Technical Specification

**Digital cellular telecommunications system (Phase 2+);
Universal Mobile Telecommunications System (UMTS);
Policy control over Gb interface
(3GPP TS 29.207 version 6.3.0 Release 6)**



Reference

RTS/TSGC-0329207v630

Keywords

GSM, UMTS

ETSI

650 Route des Lucioles
F-06921 Sophia Antipolis Cedex - FRANCE

Tel.: +33 4 92 94 42 00 Fax: +33 4 93 65 47 16

Siret N° 348 623 562 00017 - NAF 742 C
Association à but non lucratif enregistrée à la
Sous-Préfecture de Grasse (06) N° 7803/88

Important notice

Individual copies of the present document can be downloaded from:

<http://www.etsi.org>

The present document may be made available in more than one electronic version or in print. In any case of existing or perceived difference in contents between such versions, the reference version is the Portable Document Format (PDF). In case of dispute, the reference shall be the printing on ETSI printers of the PDF version kept on a specific network drive within ETSI Secretariat.

Users of the present document should be aware that the document may be subject to revision or change of status. Information on the current status of this and other ETSI documents is available at

<http://portal.etsi.org/tb/status/status.asp>

If you find errors in the present document, please send your comment to one of the following services:

http://portal.etsi.org/chaicor/ETSI_support.asp

Copyright Notification

No part may be reproduced except as authorized by written permission.
The copyright and the foregoing restriction extend to reproduction in all media.

© European Telecommunications Standards Institute 2005.
All rights reserved.

DECTTM, **PLUGTESTS**TM and **UMTS**TM are Trade Marks of ETSI registered for the benefit of its Members.
TIPHONTM and the **TIPHON logo** are Trade Marks currently being registered by ETSI for the benefit of its Members.
3GPPTM is a Trade Mark of ETSI registered for the benefit of its Members and of the 3GPP Organizational Partners.

Intellectual Property Rights

IPRs essential or potentially essential to the present document may have been declared to ETSI. The information pertaining to these essential IPRs, if any, is publicly available for **ETSI members and non-members**, and can be found in ETSI SR 000 314: "*Intellectual Property Rights (IPRs); Essential, or potentially Essential, IPRs notified to ETSI in respect of ETSI standards*", which is available from the ETSI Secretariat. Latest updates are available on the ETSI Web server (<http://webapp.etsi.org/IPR/home.asp>).

Pursuant to the ETSI IPR Policy, no investigation, including IPR searches, has been carried out by ETSI. No guarantee can be given as to the existence of other IPRs not referenced in ETSI SR 000 314 (or the updates on the ETSI Web server) which are, or may be, or may become, essential to the present document.

Foreword

This Technical Specification (TS) has been produced by ETSI 3rd Generation Partnership Project (3GPP).

The present document may refer to technical specifications or reports using their 3GPP identities, UMTS identities or GSM identities. These should be interpreted as being references to the corresponding ETSI deliverables.

The cross reference between GSM, UMTS, 3GPP and ETSI identities can be found under <http://webapp.etsi.org/key/queryform.asp>.

Contents

Intellectual Property Rights	2
Foreword.....	2
Foreword.....	5
1 Scope	6
2 References	6
3 Definitions and abbreviations.....	7
3.1 Definitions	7
3.2 Abbreviations	8
4 Go interface	9
4.1 Overview	9
4.2 Go reference model	11
4.3 Functional elements and capabilities.....	12
4.3.1 GGSN	12
4.3.1.1 Service-based local policy enforcement point.....	12
4.3.1.1.1 QoS Information processing.....	12
4.3.1.2 Initialisation and maintenance.....	13
4.3.1.3 Gate function.....	13
4.3.1.4 Void.....	14
4.3.1.5 Binding mechanism handling	14
4.3.2 PDF.....	15
4.3.2.1 Service-based local policy decision point	15
4.3.2.2 Initialisation and maintenance.....	16
4.3.2.3 Binding mechanism handling.....	16
5 Policy control procedures.....	17
5.1 GGSN	17
5.1.1 Initial authorization at PDP context activation	17
5.1.2 Modification of previously authorized PDP context.....	17
5.1.3 Session modification initiated decision.....	18
5.1.4 PDP context deactivation.....	18
5.1.5 Gate control operation	18
5.1.6 User plane operation	18
5.2 PDF	19
5.2.1 SBLP decisions	19
5.2.1.1 SBLP authorisation decision	19
5.2.1.2 Session modification initiated decision.....	21
5.2.1.3 SBLP revoke decision	21
5.2.1.4 SBLP gate decision	21
5.2.2 Support for SIP forking.....	22
5.2.2.1 Authorization of resources for forked responses.....	22
5.2.2.2 Updating the authorization information at the final answer	22
6 Go protocol.....	22
6.1 Protocol support	22
6.1.1 TCP connection for COPS protocol.....	22
6.1.2 COPS protocol	23
6.2 Basic COPS events/messages.....	23
6.2.1 Type of messages.....	23
6.3 Go events/messages.....	23
6.3.1 Event descriptions.....	24
6.3.1.1 Common Header, Client Type	24
6.3.1.2 Context Object	24
6.3.1.3 Client Specific Information (ClientSI) for outsourcing Operation.....	24
6.3.1.4 Conformance Section	24

6.3.1.5	Reporting of Device Capabilities and Device Limitations	26
6.3.1.6	Initial Go Policy Provisioning	26
6.3.2	Message description.....	26
6.4	Go data	29
6.5	Security Considerations.....	29
Annex A:	(Void).....	30
Annex B (normative):	3GPP Go PIB.....	31
Annex C (normative):	Flow identifiers: Format definition and examples.....	50
C.1	Format of a flow identifier	50
C.2	Example 1.....	51
C.3	Example 2.....	52
C.4	Example 3 without media components.....	54
C.5	Example 4.....	54
Annex D (normative):	Go interface related error code values for the PDP context handling	56
Annex E (informative):	Overview of the 3GPP Go PIB working mode	57
Annex F (informative):	Change history	59
History		60

Foreword

This Technical Specification has been produced by the 3rd Generation Partnership Project (3GPP).

The contents of the present document are subject to continuing work within the TSG and may change following formal TSG approval. Should the TSG modify the contents of the present document, it will be re-released by the TSG with an identifying change of release date and an increase in version number as follows:

Version x.y.z

where:

- x the first digit:
 - 1 presented to TSG for information;
 - 2 presented to TSG for approval;
 - 3 or greater indicates TSG approved document under change control.
- y the second digit is incremented for all changes of substance, i.e. technical enhancements, corrections, updates, etc.
- z the third digit is incremented when editorial only changes have been incorporated in the document.

1 Scope

The present document provides the stage 3 specification of the Go interface. The functional requirements and the stage 2 specifications of the Go interface are contained in 3GPP TS 23.002 [2] and 3GPP TS 23.207 [3]. The Go interface is the interface between the GGSN and the Policy Decision Function (PDF).

The present document defines:

- the protocol to be used between PDF and GGSN over the Go interface;
- the signalling interactions to be performed between PDF and GGSN over the Go interface;
- the information to be exchanged between PDF and GGSN over the Go interface.

2 References

The following documents contain provisions which, through reference in this text, constitute provisions of the present document.

- References are either specific (identified by date of publication and/or edition number or version number) or non-specific.
- For a specific reference, subsequent revisions do not apply.
- For a non-specific reference, the latest version applies. In the case of a reference to a 3GPP document (including a GSM document), a non-specific reference implicitly refers to the latest version of that document *in the same Release as the present document*.

- [1] 3GPP TR 21.905: "Vocabulary for 3GPP Specifications".
- [2] 3GPP TS 23.002: "Network architecture".
- [3] 3GPP TS 23.207: "End-to-end Quality of Service (QoS) concept and architecture".
- [4] 3GPP TS 23.228: "IP Multimedia Subsystem (IMS); Stage 2".
- [5] Void.
- [6] IETF RFC 2753: "A Framework for Policy-based Admission Control".
- [7] IETF RFC 2748: "The COPS (Common Open Policy Service) Protocol".
- [8] IETF RFC 3084: "COPS Usage for Policy Provisioning (COPS-PR)".
- [9] IETF RFC 3159: "Structure of Policy Provisioning Information (SPPI)".
- [10] Void.
- [11] IETF RFC 3520: "Session Authorization Policy Element".
- [12] 3GPP TS 24.008: "Mobile radio interface Layer 3 specification; Core network protocols; Stage 3".
- [13] 3GPP TS 27.060: "Packet domain; Mobile Station (MS) supporting Packet Switched services".
- [14] 3GPP TS 24.229: "IP Multimedia Call Control Protocol based on SIP and SDP; Stage 3".
- [15] IETF RFC 3318: "Framework Policy Information Base".
- [16] IETF RFC 3289: "Management Information Base for the Differentiated Services Architecture".
- [17] IETF RFC 2327: "SDP: Session Description Protocol".
- [18] 3GPP TS 29.208: "End-to-end Quality of Service (QoS) signalling flows".

- [19] IETF RFC 3291: "Textual Conventions for Internet Network Addresses".
- [20] 3GPP TS 29.060: "General Packet Radio Service (GPRS); GPRS Tunnelling Protocol (GTP) across the Gn and Gp interface".
- [21] 3GPP TS 32.225: "Telecommunication management; Charging management; Charging data description for the IP Multimedia Subsystem (IMS)".
- [22] IETF RFC 3313: "Private Session Initiation Protocol (SIP) Extensions for Media Authorization"
- [23] 3GPP TS 29.209: "Policy control over Gq interface".
- [24] IETF RFC 3605: "Real Time Control Protocol (RTCP) attribute in Session Description Protocol (SDP)"

3 Definitions and abbreviations

3.1 Definitions

For the purposes of the present document, the terms and definitions given in 3GPP TR 21.905 [1] and the following apply:

Application Function: The Application Function (AF) is an element offering applications that require the control of IP bearer resources. The AF is capable of communicating with the PDF to transfer dynamic QoS-related application information. One example of an AF is the P-CSCF of the IM CN subsystem.

AF session: An AF session is established by an application level signalling protocol offered by the AF that requires a session set-up with explicit session description before the use of the service. One example of an application session is an IMS session.

AF session signalling: AF session signalling is used to control the AF session. One example of AF session signalling is SIP/SDP.

Authorization Token: consists of the AF session identifier and the PDF identifier in conformance with RFC 3520 [11]. It is used for authorizing the QoS for the IP flow (s). The UE includes an authorization token as part of the binding information in order to obtain QoS authorization for the AF session. The UE obtains this authorization token via the AF session signalling from the AF, e.g. via SIP from the P-CSCF by means of an extension SIP header described in RFC 3313 [22]. The AF communicates with the PDF in order to obtain a suitable authorization token for the UE.

Binding Information: consists of an authorization token and the flow identifier(s) of IP flow(s) carried by a PDP context. When receiving an authorization token, the UE includes binding information when activating or modifying a PDP context. It is used for authorizing the QoS of the IP flows carried within a PDP context and to verify that the grouping of the IP flows is correct.

Client Handle: an object in the COPS messages used as a unique number to correlate all the COPS messages with the same dialogue. Over the Go interface the Client Handle is used to correlate COPS messages with respect to the same PDP Context. For the exact definition see RFC 2748 [7] and RFC 3084 [8].

Common Open Policy Service (COPS) protocol: is a simple query and response protocol that can be used to exchange policy information between a policy server (Policy Decision Point) and its clients (Policy Enforcement Points)

Flow identifier: used for the identification of the IP flows, described within a media component associated with an AF session. A Flow identifier consists of two parts: 1) the ordinal number of the position of the media component description in the session description information and 2) the ordinal number of the IP flow(s) within the media component description assigned in the order of increasing port numbers. Examples are provided in Annex C.

Go Interface: interface between PDF and GGSN (3GPP TS 23.002 [2])

Gq Interface: interface between PDF and the AF. It is specified in 3GPP TS 29.209 [23]

GPRS Charging ID (GCID): the Charging Id generated by the GGSN as defined in 3GPP TS 29.060 [20].

IP Bearer Service Manager: uses standard IP mechanisms to manage the IP Bearer Service. It resides in the GGSN and optionally in the UE.

IP flow: a unidirectional flow of IP packets with the same source IP address and port number and the same destination IP address and port number and the same transport protocol. Port numbers are only applicable if used by the transport protocol.

Media component: is a part of an AF session description (e.g. SDP) conveying information about media (e.g. media type, format, IP address, port(s), transport protocol, bandwidth, direction).

The media described by a media component can be either bi- or unidirectional. Media using RTP for transport may also have associated RTCP. If so, the media component also conveys information about the associated RTCP (port and possibly bandwidth). An AF session description can consist of more than one media component.

For, SDP, a media component shall not be deleted nor its position changed within the SDP session description. An SDP media component line where the port number has previously been set to 0 may be reused for a new media component.

Policy Decision Function (PDF): is a logical policy decision element that uses standard IP mechanisms to implement policy in the IP media layer

The PDF makes decisions in regard to network based IP policy using policy rules, and communicates these decisions to the PEP in the GGSN.

Proxy Call Session Control Function (P-CSCF): is a network element providing session management services (e.g. telephony call control)

Policy Enforcement Point (PEP): is a logical entity that enforces policy decisions made by the PDF. It resides in the IP BS Manager of the GGSN

Policy Information Base (PIB): is a set of policy data carried by COPS-PR

The protocol assumes a named data structure, known as a Policy Information Base (PIB), to identify the type and purpose of solicited and unsolicited policy information that is sent from the Policy Decision Point to the Policy Enforcement Point for provisioning policy or sent from the Policy Enforcement Point to the Policy Decision Point as a notification.

Provisioning Instance Identifier (PRID): uniquely identifies an instance of a PRC

QoS class: identifies a bearer service (which is associated with a set of bearer service characteristics)

Session Description Information (SDI): The set of information describing the AF session (e.g. type of media, bandwidth, IP address and port number) agreed between the UE and the AF required to perform the Service Based Local Policy (SBLP).. For example, in the IMS case, this information is negotiated between the UE and AF using SDP.

Service Information: The set of information conveyed from the AF to the PDF over the Gq interface to be used as a basis for the service-based local policy decisions at the PDF, including information about the AF session (e.g. application identifier, type of media, bandwidth, IP address and port number) and parameters controlling the PDF behavior. The encoding of the service information is provided in 3GPP TS 29.209 [23].

Translation/mapping function: provides the inter-working between the mechanisms and parameters used within the UMTS Bearer Service and those used within the IP Bearer Service

UMTS Bearer Service Manager: handles resource reservation requests from the UE. It resides in the GGSN and the UE

3.2 Abbreviations

For the purposes of the present document, the abbreviations given in 3GPP TR 21.905 [1] and the following apply:

AF	Application Function
COPS	Common Open Policy Service protocol
COPS-PR	COPS for policy PRovisioning
DEC	COPS DECision message
DRQ	COPS Delete ReQuest state message
GCID	GPRS Charging IDentifier
ICID	IM CN Subsystem Charging IDentifier

IMS	IP Multimedia core network Subsystem
MIB	Management Information Base
P-CSCF	Proxy Call Session Control Function
PDF	Policy Decision Function
PEP	Policy Enforcement Point
PIB	Policy Information Base
PRC	PRovisioning Class (a type of policy data)
PRI	PRovisioning Instance (an instance of a PRC)
PRID	PRovisioning Instance iDentifier
QoS	Quality of Service
REQ	COPS REQuest message
RPT	COPS RePorT state message
RTCP	RTP Control Protocol
SBLP	Service Based Local Policy
SDI	Session Description Information
SDP	Session Description Protocol

4 Go interface

4.1 Overview

The Go interface allows service-based local policy information to be "pushed" to or requested by the Policy Enforcement Point (PEP) in the GGSN from a Policy Decision Function (PDF). As defined in the stage 2 specifications 3GPP TS 23.207 [3], this information is used by the GGSN for:

- GPRS bearer authorisation;
- Charging correlation;
- Policy based "gating" function in GGSN;

The Go interface uses IP flow based policies.

The Common Open Policy Service (COPS) protocol has been developed as a protocol for use between a policy server and a network device, as described in RFC 2748 [7].

In addition, COPS for Provisioning extensions have been developed as described in RFC 3084 [8] with RFC 3159 [9] describing a structure for specifying policy information that can then be transmitted to a network device for the purpose of configuring policy at that device. The model underlying this structure is one of well-defined provisioning classes and instances of these classes residing in a virtual information store called the Policy Information Base (PIB).

The Go interface shall conform to the IETF COPS (RFC 2748 [7]) and the extensions of COPS-PR (RFC 3084 [8]). For the purpose of exchanging the required specific Go information, a 3GPP Go COPS-PR Policy Information Base (PIB) is defined in the present document.

COPS Usage for Policy Provisioning (COPS-PR) is independent of the type of policy being provisioned (QoS, Security, etc.). In the present document, COPS-PR is used to communicate service-based local policy information between PDF and GGSN. COPS-PR can be extended to provide per-flow policy control along with a 3GPP Go Policy Information Base (PIB). The 3GPP Go PIB may inherit part of the data object definitions from other PIBs and MIBs defined in the IETF.

Signalling flows related to the Go interface are specified in 3GPP TS 29.208 [18].

The minimum functionalities that the Go interface shall cover are introduced below.

1. Media Authorisation request from GGSN:

The GGSN receives the binding information during the activation of a (Secondary) PDP context or during the modification of an existing PDP context that has been previously authorized by the PDF. To authorise the PDP context activation, the GGSN shall send a media authorisation request to the PDF. To authorise the PDP

context modification, the GGSN shall send a media authorisation request to the PDF when the requested QoS exceeds the authorised QoS or new binding information is received.

This authorisation request shall include the following information:

- Binding information:

The binding information is used by the GGSN to identify the correct PDF and subsequently request service-based local policy information from the PDF. The GGSN may receive one or more sets of the binding information during an activation or modification of a PDP context. Each set of binding information consists of:

- One Authorisation token;
- One or more Flow identifiers within the session.

2. Media authorisation decision from PDF:

The media authorisation information sent by the PDF to the GGSN, contains at a minimum the following information:

- Decision on the binding information.

The PDF shall respond with an authorisation decision for the binding information. The authorisation decision shall identify that the binding information is validated with an ongoing AF session. Additionally, the PDF shall verify if the IP flows of the multiple media components are correctly assigned to the PDP Context. If validated, the PDF shall also communicate the following media authorisation details to the GGSN:

- "Authorised QoS".

This information is used by the GGSN to authorise the media resources according to the service-based local policy and the requested bearer QoS.

The "Authorised QoS" signalled over the Go interface is based on the service information requirements conveyed over the Gq interface, which are based on SDI possibly signalled and agreed previously within AF session signalling for this session.

The "Authorised QoS" specifies the maximum QoS that is authorised for a PDP context for that specific binding information. In case of an aggregation of multiple media components within one PDP context, the combination of the "Authorised QoS" information of the individual IP flows of the media components is provided as the "Authorised QoS" for the bearer.

The "Authorised QoS" contains the following information:

- QoS class:

The QoS class information represents the highest class that can be used for the media component. It is derived from the service information received from the AF. The QoS class within the "Authorized QoS" information for the bearer is determined from the QoS class values of the individual IP flows of these media components identified in the binding information.

- Data rate:

The Data rate information is derived from the service information. In the IMS case, it is derived from the SDP bandwidth parameters converted by the P-CSCF to bandwidth information within the service information. The Data rate includes all the overhead coming from the IP-layer and the layers above, e.g. UDP, RTP or RTCP. If multiple codecs are agreed to be used in a session, the authorized data rate is set according to the codec requiring the highest bandwidth, meaning that terminals may under use the authorized data rate when choosing to use another agreed codec. The Data rate within the "Authorized QoS" information for the bearer is determined from the data rate values of the individual IP flows identified in the binding information.

- Packet Classifier.

The packet classifier for media components is based on the IP-address and port number information in the service information and shall allow for all IP flows associated with the service information media component description.

3. Charging correlation:

The PDF may send the AF charging information e.g. ICID (see 3GPP TS 24.229 [14]) provided by the P-CSCF in the IMS case, as part of the authorisation decision. The GGSN shall send the GCID (see 3GPP TS 29.060 [20]) of the PDP Context and the GGSN address to the PDF as part of the authorisation report.

4. Approval of QoS Commit / Removal of QoS Commit / Revoke Authorisation for GPRS and IP resources:

The PDF controls media components and may revoke resources at any time. Approval of QoS Commit / Removal of QoS Commit / Revoke Authorisation for GPRS and IP resources is communicated by the PDF to the GGSN.

5. Indication of PDP Context Release / Modification to/from 0 kbit/s:

The GGSN informs the PDF of bearer changes related to the authorised resources for the AF session in the following cases:

- Loss of radio contact (modification to/from 0 kbit/s for conversational and streaming class);
- Deactivation of PDP context.

4.2 Go reference model

The Go interface is defined between the PDF and the GGSN (3GPP TS 23.002 [2]).

The PDF is in the same PLMN as the GGSN.

The relationships between the different functional entities involved are depicted in figure 4.2.

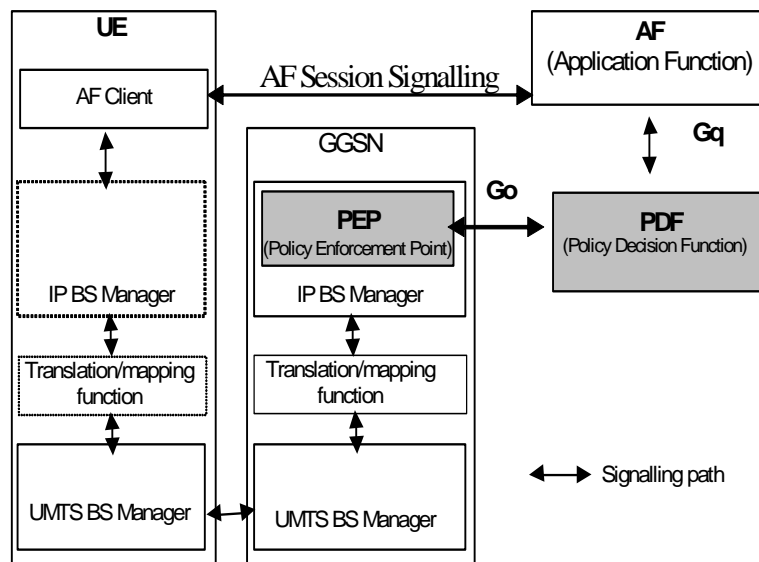

NOTE: For clarity in the diagram, network elements that are not involved in service-based local policy are not presented here (e.g. radio network elements, SGSN, etc).

Figure 4.2: Go interface architecture model

4.3 Functional elements and capabilities

4.3.1 GGSN

4.3.1.1 Service-based local policy enforcement point

The Policy Enforcement Point (PEP) is a logical entity which resides in the GGSN and communicates with the PDF regarding Service-based local policy (SBLP) control. Hereafter in the present document, the GGSN is assumed to contain the PEP implicitly unless otherwise stated. The GGSN sends requests to and receives decisions from the PDF. The GGSN may cache the policy decision data of the PDF decisions. This cached information may be used later for a local policy decision allowing the GGSN to make policy control decision about the QoS authorization for PDP context modifications without requiring additional interaction with the PDF in case the modification request does not exceed the previously authorized QoS.

The following policy enforcement point functionalities for SBLP in the GGSN are identified:

- Policy based Authorisation:

The GGSN requests authorisation information from the PDF for the IP flows carried by a PDP context. The GGSN enforces the PDF decisions for this PDP context.

The GGSN shall enforce unsolicited authorisation decisions which update the QoS and packet classifiers.

Additionally, policy-based authorisation ensures that the resources, which can be used by the PDP context are within the "Authorised QoS" specified by the PDF. This information is mapped by the Translation/mapping function in the GGSN to give the authorised resources for GPRS bearer admission control.

The GGSN shall also report to the PDF its success or failure in carrying out the PDF decision.

- Policy based gating functionality:

Policy based gating functionality represent the control of the GGSN over the Gate Function in the user plane, i.e. the forwarding of IP packets associated with a media component. In the user plane, a "gate" is defined for each IP flow of a media component. The PDF provides the gate description and the commands to open or close the gate. The gate description is received from the PDF in the authorisation decision. The command to open or close the gate shall be sent either in the authorisation decision or in subsequent decisions from the PDF.

- Indication of bearer release/modification to/from 0 kb/s:

The GGSN shall inform the PDF when the bearer changes to or from a data rate of 0 kb/s (an indication of bearer loss/recovery), and at bearer release.

- Charging Correlation

To ensure charging correlation, the PEP shall send the GCID and the GGSN address to the PDF. The PDF shall also send the AF charging identifier, if available, to the GGSN.

4.3.1.1.1 QoS Information processing

The GGSN is responsible for the policy based authorisation, i.e. to ensure that the requested QoS is in-line with the "Authorized QoS".

The GGSN needs the "Authorised QoS" information of the PDP context for the uplink as well as for the downlink direction. Therefore, the "Authorized QoS" information for the combination of all IP flows of each direction associated with the media component as determined by the PDF is used.

In case of an aggregation of multiple media components within one PDP context, the "Authorised QoS" for the bearer is provided by the PDF as the combination of the "Authorised QoS" information of the individual media components.

The GGSN shall perform the proper mapping between the IP QoS information and the UMTS QoS information. This mapping is performed by the Translation/mapping function which maps the "Authorised QoS" information for the PDP context into authorised UMTS QoS information.

The GGSN shall derive the highest allowed UMTS Traffic class for the PDP context from the QoS class in the "Authorized QoS" according to table 4.3.1.1.1.

Table 4.3.1.1.1

QoS class	UMTS Traffic Class	Traffic Handling Priority
A	Conversational	N/A
B	Streaming	N/A
C	Interactive	1
D		2
E		3
F	Background	N/A
NOTE: QoS class represents the highest class that can be used for the bearer.		

The QoS class values given by the PDF are equal for both the uplink and the downlink directions.

The Data rate within the "Authorized QoS" information for the bearer is the combination of the data rate values of the "Authorised QoS" of the individual IP flows of the media components.

In the case of real-time UMTS bearers (conversational and streaming traffic classes), the GGSN shall consider, the Data rate value of the "Authorized QoS" information as the maximum value of the 'Guaranteed bitrate' UMTS QoS parameter, whereas the 'Maximum bitrate' UMTS QoS parameter is limited by the subscriber and service specific setting in the HLR/HSS (SGSN) and by the capacity/capabilities/service configuration of the network (GGSN, SGSN). In the case of non-real-time bearers (interactive and background traffic classes) the GGSN shall consider, the Data rate value of the "Authorized QoS" information as the maximum value of the 'Maximum bitrate' UMTS QoS parameter.

The UMTS BS Manager receives the authorised UMTS QoS information for the PDP context from the Translation/mapping function. If the requested QoS exceeds the authorised QoS, the UMTS BS Manager shall downgrade the requested UMTS QoS information to the authorised UMTS QoS information.

The GGSN may store the authorized QoS for the binding information of an active PDP context in order to be able to make local decisions, when the UE requests for a PDP context modification.

4.3.1.2 Initialisation and maintenance

The GGSN shall comply to the procedures described in RFC 2748 [7] for the initialisation and maintenance of the COPS protocol over the Go interface.

4.3.1.3 Gate function

The Gate Function represents a user plane function enabling or disabling the forwarding of IP packets. A gate is described by a set of packet classifiers that identify IP flows associated to the gate. The packet classifier includes the standard 5-tuple (source IP address, destination IP address, source port, destination port, protocol) explicitly describing a unidirectional IP flow.

The packet classifier is received from the PDF in an authorisation decision.

The GGSN installs the packet filter corresponding to the packet classifier. The packet classifier includes the status that the gate shall be set to.

The commands to open or close the gate lead to the enabling or disabling of the passage for IP packets. If the gate is closed all packets of the related IP flows are dropped. If the gate is opened the packets of the related IP flows are allowed to be forwarded. The opening of the gate may be part of the authorisation decision event. The closing of the gate may be part of the revoke authorisation decision event.

IP Packets matching a SBLP supplied filter are subject to the gate associated with that packet filter. In the uplink direction, IP packets which do not match any SBLP supplied filter shall be silently discarded. In the downlink direction, IP packets which do not match any SBLP supplied filter shall be matched against TFT supplied filters that are installed for PDP contexts where SBLP is not applied.

4.3.1.4 Void

4.3.1.5 Binding mechanism handling

The binding information is used by the GGSN to identify the correct PDF and subsequently request service-based local policy information from the PDF. The binding information associates a PDP context with one or more media components or IP flows of an AF session. The GGSN may receive one or more sets of the binding information during an activation or modification of a secondary PDP context. Each set of binding information consists of an authorisation token and the flow identifier(s) related to the IP flow(s) within the same session

The GGSN shall store the binding information and apply it to correlate events and actions between the PDP context and the service-based local policy.

The GGSN shall determine the IP address of the PDF from the PDF identifier received as part of the Authorization Token. This identifier shall be in the format of a fully qualified domain name. If the GGSN receives multiple sets of binding information in the secondary PDP context activation, the GGSN shall search for the first Authorization Token containing the PDF identifier (Authorization Token is of type AUTH_SESSION and contains AUTH_END_ID) and use that to identify the correct PDF. If none of the tokens included in the binding information are of type AUTH_SESSION, or they do not contain an AUTH_ENT_ID attribute to resolve the PDF address, then the GGSN shall reject the secondary PDP context activation request. The reason for the rejection is indicated to the UE with the error code value "Invalid binding information" (see annex D).

The GGSN shall forward the binding information received from the UE to the PDF. If multiple sets of binding information are received by the GGSN, it shall forward them to the PDF.

If the binding information is successfully modified using the PDP context modification procedure, the GGSN shall replace the old binding information with the new binding information.

When the GGSN receives a secondary PDP context activation request to an APN for which the Go interface is enabled and no binding information is received, the GGSN may either reject the secondary PDP context activation request, or accept it within the limit imposed by a locally stored QoS policy. This local QoS policy shall be operator configurable within the GGSN. If the request is rejected, the reason for the rejection is indicated to the UE with the error code value "Missing binding information" (see annex D). If the requested PDP context is **non-realtime (UMTS Traffic class 'background' or 'interactive')** and such a PDP context is not yet assigned for the UE for the same APN, then the GGSN shall accept the secondary PDP context activation request **without binding information and SBLP authorization. If such a PDP context is already assigned, then the GGSN may accept the secondary PDP context request according to operator policy.**

When the GGSN receives a PDP context modification request for a secondary PDP context to an APN for which the Go interface is enabled, and no binding information is received (e.g. due to a SGSN initiated PDP context modification of maximum bitrate to 0 kbit/s), the GGSN shall accept the PDP context modification if binding information has been previously provided for the PDP context. SBLP still applies for this PDP context. If a request for service-based local policy information from the PDF is necessary, the GGSN shall use the stored binding information of this PDP context.

If no binding information has previously been received, the GGSN may either reject the PDP context modification request, or accept it within the limit imposed by a locally stored QoS policy. This local QoS policy shall be operator configurable within the GGSN. If the request is rejected, the reason for the rejection is indicated to the UE with the error code value "Missing binding information" (see annex D). If the modified PDP context is **non-realtime (UMTS Traffic class 'background' or 'interactive')**, then the GGSN shall accept the secondary PDP context modification request **without binding information and SBLP authorization.**

When binding information is received, the GGSN shall ignore any UE supplied TFT, and filters in that TFT shall not be installed in the packet processing table.

The GGSN shall reject a secondary PDP context activation or PDP context modification request with the error code "Binding information not allowed" (see annex D) in the following cases:

- The Go interface is disabled and the GGSN receives a Create PDP Context Request or Update PDP Context Request message that includes binding information.
- The GGSN receives a Create PDP Context Request or Update PDP Context Request message that includes both binding information and the IM CN Subsystem Signalling Flag.

- The GGSN receives an Update PDP Context Request message that includes binding information to modify a previously non-authorized PDP context.

4.3.2 PDF

4.3.2.1 Service-based local policy decision point

The PDF functions as a Policy Decision Point for the service-based local policy control. The PDF makes policy decisions based on session and media related information obtained from the AF via the Gq interface. The PDF shall exchange the decision information with the GGSN via the Go interface.

The following policy decision point functionalities for SBLP are identified:

- Authorisation function:

The PDF shall be able to provide an authorisation decision upon receiving a bearer authorisation request from the GGSN. The PDF shall authorise the request according to the stored session and media related information received from the AF.

The PDF shall use the binding information to determine the AF session(s) and the set of IP flows. Multiple sets of binding information and multiple AF sessions may be involved, if flows from separate AF sessions are multiplexed in the same PDP context. Based on the IP flows, the PDF shall determine the authorised QoS, packet filters, and gate status to be applied. The authorised QoS specifies the maximum allowed QoS class, and the data rate for the set of IP flows identified in the binding information.

The PDF shall be able to provide updates to the authorisation decision, if receiving modified service information from the AF which changes the QoS and packet classifiers for PDP contexts which are already established.

- Revoke function:

The PDF may revoke the authorisation of resources at any time. Revoke Authorisation for GPRS and IP resources is communicated by the PDF to the GGSN.

- Approval of QoS Commit / Removal of QoS Commit:

The PDF may allow or deny the usage of the PDP context for the selected IP flow(s) by controlling the correlated gate(s).

The "Approval of QoS Commit" command may either be part of the authorisation decision, or the PDF may provide a separate decision with the "Approval of QoS Commit" command to open the gate.

The "Removal of QoS Commit" command is a separate decision to close the gate(s) e.g. when a media IP flow(s) is put on hold.

- Actions due to Indication of bearer release:

When the GGSN informs the PDF of bearer deactivation, the PDF shall remove the corresponding authorisation request state. Additionally, the PDF shall inform the AF about this deletion event.

- Actions due to Indication of bearer modification:

When the PDF receives an indication of bearer modification of the maximum bitrate to or from 0 kbits/s, the PDF shall inform the AF about this modification event.

- Generation of authorisation token:

The PDF generates an authorisation token for the AF session as specified in 3GPP TS 29.209 [23].

- Mapping service information to "Authorized QoS" parameters:

To perform proper authorisation, the PDF shall map the necessary service information containing session and media related information to "Authorized QoS" parameters.

- Charging identifiers exchange:

The PDF shall send the AF charging information (e.g. ICID if the AF is P-CSCF) , if provided by the AF, as part of the initial authorisation decision(s) for all the bearer authorization request(s) that correspond to the respective AF session.

When the PDF receives the GCID together with the GGSN address from the GGSN, it shall forward this information to the AF to ensure charging correlation. This information should not be forwarded over an inter-operator interface.

4.3.2.2 Initialisation and maintenance

The PDF shall comply to the procedures described in RFC 2748 [7] for the initialisation and maintenance of the COPS protocol over the Go interface.

4.3.2.3 Binding mechanism handling

The binding information is used by the GGSN to identify the correct PDF and subsequently request service-based local policy information from the PDF. Each set of binding information consists of an authorisation token and one or more flow identifier(s).

The PDF generates an Authorisation Token for the AF session as specified in 3GPP TS 29.209 [23]. The Authorisation token shall be sent to the AF which forwards it to the UE in the AF session signalling. The PDF shall provide its PDF identifier as part of the Authorization Token. This identifier shall be in the format of a fully qualified domain name.

The PDF receives the binding information and a Client Handle as part of a REQ from the GGSN. The PDF shall store the Client Handle for each flow identifier identified by the binding information for subsequent message exchanges.

The authorisation token is applied by the PDF to identify the AF session. If flows from separate AF sessions are multiplexed in the same PDP context, there are more than one authorization token, and the PDF identifies one AF session per each token. If no AF session can be found for an authorisation token, or if the authorization token for the Client Handle has been modified, or if the PDF is otherwise unable to authorise the binding information, the PDF shall send a COPS decision message carrying both an INSTALL and REMOVE decision. The INSTALL decision shall identify an authorisation failure to the GGSN, and may include further details identifying the cause. The REMOVE decision shall subsequently remove this state from the GGSN. The "Request State" flag shall not be set within the REMOVE decision. For an initial authorisation, the GGSN will send a COPS Delete Request State (DRQ) message to the PDF to clean up the corresponding COPS handle.

For a valid authorisation token the flow identifier(s) are used to select the available information on the IP flows of this AF session. The PDF sends the available authorisation information back to the GGSN. If there are more than one authorization tokens per client handle, the authorization information comprises an aggregate of the information of all related flows. If the PDF has already communicated authorisation for the same authorisation token and flow identifier(s) to this (or another) GGSN on this AF session, then the previous authorisation shall be revoked, and this revocation shall be communicated to the appropriate GGSN.

If the binding information consists of more than one flow identifier, the PDF shall also verify that the media components identified by the flow identifiers are allowed to be transferred in the same PDP context. If any of these media components was mandated to be carried in a separate PDP Context, the PDF shall send a COPS decision message carrying both an INSTALL and REMOVE decision. The INSTALL decision shall identify an authorisation failure to the GGSN, and may include further details identifying the cause. The REMOVE decision shall subsequently remove this state from the GGSN. For an initial authorisation, the PDF shall then initiate a remove for the authorisation request.

For a valid binding information consisting of more than one flow identifier, the information sent back to the GGSN shall include the aggregated QoS for all the IP flows and suitable packet filter(s) for these IP flows. If there are more than one sets of binding information per client handle, the authorization information comprises an aggregate of the information of all related flows. Each flow identifier within the binding information can identify one or more IP flows of a single media component.

5 Policy control procedures

5.1 GGSN

5.1.1 Initial authorization at PDP context activation

The GGSN may receive binding information during the activation of a secondary PDP context by the UE. To perform initial authorization at the secondary PDP context activation the GGSN shall send an authorisation request to the PDF including the binding information received from the UE.

The GGSN identifies the required PDF from the authorisation token of the binding information. The authorisation token is formatted according to the structure of the policy element AUTH_SESSION defined in RFC 3520 [11]. The policy element AUTH_SESSION shall include the AUTH_ENT_ID and the SESSION_ID attributes. The GGSN checks for that Policy Element and retrieves the AUTH_ENT_ID attribute from this. If this is in the form of a Fully Qualified Domain Name, then this is used to identify the correct PDF.

The GGSN authorisation request message to the PDF shall allow the GGSN to request policy information for authorisation of the IP flows identified by the flow identifiers within the binding information carried by a PDP context.

When the GGSN receives the PDF decision, the GGSN shall enforce the policy decision. To enforce the policy decision, the GGSN shall install the packet filters received from the PDF, and ignore the UE supplied TFT.

If the PDF decision information indicates that the binding information provided by the GGSN is authorised, the GGSN shall proceed with activation of the secondary PDP context. The GGSN shall map the authorized QoS resources into authorized resources for the bearer admission control.

To ensure charging correlation, the GGSN shall send the GCID and GGSN address information to the PDF after the successful establishment of the secondary PDP context, i.e. with the report following the initial authorization decision.

When the PDF detects that the binding information provided by the GGSN is not associated with an ongoing AF session at application layer, or is otherwise unable to authorise the binding information, the GGSN will receive a COPS decision message from the PDF carrying both an INSTALL and REMOVE decision. The "Request State" flag is not set within the REMOVE decision. The reason for the rejection is indicated by the INSTALL decision with an appropriate authorisation request failure reason. The GGSN shall reject the secondary PDP context activation with a corresponding error code, see annex D. The GGSN shall subsequently remove this state according to the REMOVE decision. For an initial authorisation request, the GGSN shall then send a COPS Delete Request State (DRQ) message to the PDF to remove the state in the GGSN and the PDF.

When the GGSN sends an authorization request to the PDF but the PDF does not respond with the decision message or the communication between the GGSN and the PDF fails, the GGSN shall reject the secondary PDP context activation with the error code "Authorizing entity temporarily unavailable" (see annex D).

5.1.2 Modification of previously authorized PDP context

The GGSN is responsible for notifying the PDF when a procedure of PDP context modification of a previously authorized PDP context is performed. A modification of a previously authorized PDP Context may occur for example when a new media component is added or when the codec change requires new resources. To authorise the PDP context modification the GGSN shall send an authorisation request to the PDF including the binding information received from the UE in the following cases:

- Requested QoS exceeds "Authorised QoS";
- New binding information is received.

The GGSN on receiving the PDP context modification request from the UE will verify the authorisation. If the GGSN does not have sufficient information to authorize the PDP context modification request then the GGSN shall interrogate the PDF for modification request authorisation.

If the requested QoS is within the already "Authorized QoS" and the binding information is not changed, the GGSN need not send an authorization request to the PDF.

If the PDF does not respond with a decision message to an authorization request sent by the GGSN or the communication between the GGSN and the PDF fails, the GGSN shall reject the PDP context modification with the error code "Authorizing entity temporarily unavailable" (see annex D).

When the GGSN receives an authorisation decision as response from the PDF containing a set of packet classifiers, the GGSN shall install this set of packet classifiers, removing any existing packet classifiers that are not included in this set.

The GGSN is responsible for notifying the PDF, by sending a COPS Report State (RPT) message, when the procedure of the PDP context modification is performed in the following cases:

- Requested QoS maximum bit rate is 0 kbit/s;
- Requested QoS maximum bit rate changes from 0 kbit/s.

5.1.3 Session modification initiated decision

The PDF may receive updated service information from the AF, conveying information about an AF session modification. An AF session modification may occur that modifies the media without adding or removing media component, for example, a change in the bandwidth for the media component, or a change to the port number. The GGSN will receive unsolicited authorisation decision from the PDF due to such modifications.

When the GGSN receives an unsolicited authorisation decision from the PDF with updated QoS information, the GGSN shall update the stored authorised QoS. If the existing QoS of the PDP context exceeds the updated authorised QoS, the GGSN shall initiate a timer for the UE to modify the PDP context to decrease the QoS to within the authorised limit. At expiry of the timer, if the PDP context still exceeds the authorised QoS, the GGSN shall perform a network initiated PDP context modification to reduce the QoS to the authorised level.

When the GGSN receives an unsolicited authorisation decision from the PDF, the GGSN shall also install the new set of packet classifiers, removing any existing packet classifiers that are not included in the new set.

5.1.4 PDP context deactivation

The GGSN is responsible for notifying the PDF when a procedure of a PDP context deactivation is performed. In case of a PDP context deactivation, the GGSN shall inform the PDF of the bearer release related to the AF session(s) by sending a COPS Delete Request State (DRQ) message.

When a revoke authorisation procedure is performed, the GGSN receives a decision message from the PDF for disabling the use of the "Authorised QoS" resources and deactivation of the PDP context associated with the binding information. The GGSN shall disable the use of the "Authorized QoS" resources. The GGSN shall initiate deactivation of the PDP context in case that the UE has not performed it yet.

5.1.5 Gate control operation

Upon receiving a gate decision from the PDF, the GGSN shall enforce this decision on the user plane. For each gate contained in the gate decision the GGSN shall perform the specified command. In case of an "Approval of QoS Commit" command the GGSN shall open the corresponding gate. In case of a "Removal of QoS Commit" command the GGSN shall close the corresponding gate.

5.1.6 User plane operation

The GGSN shall enforce the configuration of the policy based "gating" functionality according to additional authorisation information received from the PDF.

The filter(s) and associated gate(s) are connected to the PDP contexts where SBLP applies. For each such PDP context, the information received in the TFT is ignored. In the downlink direction, packets are processed against each filter in turn until a match is found. If a match is not found, packet processing shall then continue against filters installed from UE supplied TFTs for PDP contexts where SBLP is not applied. If a match is found against an SBLP supplied filter, the packet shall be processed according to the associated gate function. If the gate is open, the packet shall be passed to the UE on the associated PDP context. If the gate is closed, the packet shall be silently discarded.

In the uplink direction, packets received on a PDP context with SBLP supplied filters shall be matched against those filters. If a match is found, the packet shall be passed if the gate associated with that filter is open. If the gate is closed, or if the packet does not match any of the packet filters, the packet shall be silently discarded.

5.2 PDF

5.2.1 SBLP decisions

5.2.1.1 SBLP authorisation decision

The service information needed in the PDF to perform media authorization is provided by the AF via the Gq interface. The Gq interface between the AF and the PDF is specified in the 3GPP TS 29.209 [23].

The PDF should authorize all media components if no application ID is available within the service information.

The PDF stores the authorised policy information based on the service information received from the AF, and uses an Authorisation Token to identify this decision.

The Authorisation Token is in the form of a Session Authorisation Data Policy Element as described in RFC 3520 [11]. The PDF shall include an AUTH_ENT_ID attribute containing the Fully Qualified Domain Name of the PDF and the SESSION_ID attribute.

Upon receiving the bearer authorization request from the GGSN, the PDF shall authorize the request according to the stored service based local policy information for the session(s) identified by the binding information in the request.

- Decision on the binding information:
 - The authorisation shall contain the decision on verifying the binding information. The PDF shall identify whether each set of the binding information indeed corresponds to an initiated AF session. If the corresponding AF session cannot be found for a set of binding information or the binding information contains invalid flow identifier(s), or the authorization token(s) has changed in an authorization modification request, the PDF shall enforce the rejection of this PDP context request by sending an INSTALL and REMOVE decision to the GGSN. The reason for the rejection is indicated by the INSTALL decision with the "noCorrespondingSession" reason in the Authorisation Request Failure Decision. If the PDF is otherwise unable to authorise the binding information, the INSTALL decision shall identify a general authorisation failure with the "authorisationFailure" of the request reason in the Authorisation Request Failure Decision.
 - If the PDF is unable to get sufficient service information from the AF to authorise the binding information, the PDF may enforce the rejection of this PDP context request by sending an INSTALL and REMOVE decision to the GGSN. The reason for the rejection is indicated by the INSTALL decision with the "authorisationFailure" reason in the Authorisation Request Failure Decision.
 - The authorization shall also contain the decision on the list of flow identifiers contained in the bearer authorisation request sent by the GGSN representing the IP flows of the media components intended to be carried in the same PDP Context. This decision shall verify that these IP flow(s) are indeed allowed to be carried in the same PDP Context. The PDF shall make this decision by comparing the list of flow identifiers contained in the bearer authorization request received from the GGSN to the media component grouping indication information received from the AF.
 - In case the UE violates the AF level indication, and attempts to set up IP flows of multiple media components in a single PDP context despite of an indication that mandated separate PDP contexts, the PDF shall enforce the rejection of this PDP context request by sending an INSTALL and REMOVE decision to the GGSN. The reason for the rejection is indicated by the INSTALL decision with the "invalidBundling" reason in the Authorisation Request Failure Decision.

- If the sets of binding information and the list of flow identifiers are successfully authorised (verified) as per the means described above, the PDF shall also communicate the authorisation details to the GGSN.
- If the PDF has already communicated authorisation for the same authorisation token(s) and flow identifier(s) to this (or another) GGSN, then the previous authorisation shall be revoked, and this revocation shall be communicated to the GGSN.
- The authorisation details contain the "Authorised QoS" and the packet classifier(s) of the IP flows. In case of an aggregation of multiple media components within one PDP context, the combination of the "Authorised QoS" information of the individual IP flows of the media components is provided as the "Authorised QoS".
- Based on the media direction information and the direction of the source provided by the AF, the PDF shall define the direction (upstream or downstream) of the "Authorised QoS" and the packet classifier(s).
- Packet classifier(s):
 - The PDF shall derive the uplink and downlink packet classifiers from the IP addresses and port numbers for uplink and downlink IP flows provided by the AF as part of the service information. The PDF should not modify the address and port information received from the AF.
 - The PDF shall send the destination address and the destination port number for each IP flow associated with the media component.
- "Authorized QoS":
 - The "Authorised QoS" information (consisting of maximum QoS Class and Data Rate) for IP flows of media is extracted from the service information received from the AF, e.g. from the media type information, bandwidth information and AF application ID. The PDF should select the QoS Class which is the highest class that can be used for the media. The PDF shall use an equal QoS Class for both the uplink and the downlink directions when both directions are used.
 - The PDF shall derive the Data Rate value for the IP flow (s) from the service information , e.g. from contained bandwidth information, received from the AF.
 - For non-real-time bearers the Data rate value shall be considered as the maximum value of the 'Maximum bitrate' parameter.
 - In case of an aggregation of multiple media components within one PDP context, the PDF shall provide the "Authorised QoS" for the bearer as the combination of the "Authorised QoS" information of the individual IP flows of the media components. The QoS Class in the "Authorised QoS" for the bearer shall contain the highest QoS class amongst the ones applied for the individual IP flows and indicates the highest UMTS traffic class that can be applied to the PDP context.
 - The Data Rate of the "Authorised QoS" for the bearer shall be the sum of the Data Rate values of the individual media IP flows of components and it is used as the maximum Data Rate value for the PDP context.
 - The detailed rules for calculating the "Authorized QoS" are specified in 3GPP TS 29.208 [18].

The PDF shall either include the gate enabling command as part of the authorisation decision, or the PDF may provide a separate decision for opening the gate, depending on the gating policy indicated as part of the service information received from the AF.

The PDF shall send the AF charging identifier possibly provided by the AF as part of the authorisation decision to the GGSN.

Upon receiving the modified service information from the AF, the PDF shall update the media authorization information for the session. The PDF may push this updated authorisation information to the GGSN. Under certain condition e.g. revoke of authorization, the PDF shall push the updated policy decision to the GGSN. If there are IP flows of several sessions under the same client handle, the PDF shall include the aggregate authorization information of all of these flows in the push decision.

5.2.1.2 Session modification initiated decision

The PDF may receive updated service information from the AF, conveying information about an AF session modification. A session modification may occur that modifies the media without adding or removing media components, for example, a change in the bandwidth for the media component, or a change to the port number.

When there are updates to the media components which are currently authorised, the authorisation information (QoS, packet classifiers) may change. The updated information (QoS, packet classifiers) shall be pushed down to the GGSN using an unsolicited authorisation decision.

However, if the update for media components which are currently authorised happens in the way of only changing a bidirectional media (Flow status "ENABLED") to unidirectional (Flow status "ENABLED-UPLINK" or "ENABLED-DOWNLINK"), then the updated QoS information shall not be pushed down to the GGSN. In this case "Removal of QoS commit" for the deactivated direction of the media shall be sent to the GGSN to close the gate in that direction.

5.2.1.3 SBLP revoke decision

Upon release of an AF session of a given client handle (PDP context) the PDF shall send a revoke authorisation decision to the GGSN after an operator specific time. The revoke authorisation decision shall be sent for each handle (PDP context) related to the session as a separate decision to the GGSN corresponding to the previous SBLP authorisation decision.

The timer for a pending session release shall be terminated if the PDF receives an indication on the deactivation (If there are no more media streams in a PDP context, the UE will remove this PDP) or new authorisation request with the same handle where the IP flow(s) of the released AF session have been removed (If at least one media stream is still present in the PDP context, the UE will modify this PDP context) of each of the PDP context(s) related to the released session.

Additionally, when a media component which is bound to a PDP context is removed from an AF session and the UE has not performed the corresponding modification or deactivation of the PDP context within an operator specific time the PDF shall revoke the authorisation for the set of IP flows of the media components on that PDP context.

The timer for a pending media component removal shall be terminated if the PDF receives either a new authorisation request with the same handle where the IP flows of that media component has been removed, or an indication of the termination of the PDP context.

NOTE: The values of the timers for session termination and media component removal might be different, e.g. to allow for some more time for the required modification of the PDP context.

If the PDF receives a request from a GGSN for the same authorisation token and flow identifier(s) that this (or another) GGSN was already communicated authorisation, then the previous authorisation shall be revoked, and this revocation shall be communicated to the GGSN.

5.2.1.4 SBLP gate decision

Updated service information received from the AF may demand that the PDF enables or disables IP flows. The PDF may send a gate decision whenever the status of a media component changes during the session (e.g. the media IP flow(s) of a media component is put on hold or resumed, or a media component is removed), or when a session is released and the related IP flows are removed from a PDP context that multiplexes IP flows from several sessions. The PDF shall not send a gate decision to the GGSN before it has sent the initial authorisation decision. If the initial authorisation decision has already been sent, the PDF shall send a gate decision to the GGSN to modify the status of one or several gate(s) on the user plane. The gate decision shall only contain the gate(s) for which the status was changed compared to the last authorisation or gate decision sent to the GGSN. The gate decision contains for each gate either the "Approval of QoS Commit" command to open the gate or the "Removal of QoS Commit" command to close the gate. The open gate command may either be a part of the authorization decision or the PDF may provide a separate decision with the "Approval of QoS Commit" command to open the gate. When a media IP flow is put on hold, the PDF may send the "Removal of QoS Commit" command to the GGSN to close the relevant gate – the possible RTCP gate shall be left open to keep the connection alive. The open gate command shall be used to resume the media from hold.

5.2.2 Support for SIP forking

The PDF shall be able to handle SIP forking when SBLP is applied. For the IMS, forking can occur as specified in 3GPP TS 23.228 [4].

5.2.2.1 Authorization of resources for forked responses

As part of the service information, the PDF is informed by the AF if the second or subsequent SIP early dialogues are encountered within one SIP session. The AF provides separate service information for each SIP dialogue. The PDF shall allocate the same authorization token to all the early dialogues within one AF session.

For the second, and any subsequent early dialogue, the PDF shall identify the existing authorization information for that session. The PDF shall authorize any additional media components and any increased QoS requirements for the previously authorized media components, as requested by the forked response. Thus, the QoS authorized for a media component shall be equal to the highest QoS requested for that media component by any of the forked responses. Authorization is done by the procedures for authorization request in subclauses 5.1.1 and 5.1.2 and SBLP decisions in subclause 5.2.1.1.

Additional packet classifiers as required by the subsequent responses are sent to the GGSN by the session modification initiated decision specified in subclause 5.2.1.2.

5.2.2.2 Updating the authorization information at the final answer

As part of the service information, the PDF is informed by the AF when the first SIP early dialogue is progressed to establish the final SIP session. All the other early dialogues are terminated. The authorization information for the SIP session is updated to match the requirements of the remaining early dialogue only. Several actions may be needed in the PDF:

- Only the packet classifiers and the QoS indicated by the first final answer shall remain authorized. This information shall be sent to the GGSN by the session modification initiated decision specified in subclause 5.2.1.2. This should be done without delay in order to reduce the risk for initial clipping of the media stream, and minimising possible misuse of resources.
- The authorization for PDP contexts that were used only for the terminated early dialogues, shall be revoked as specified in subclause 5.1.4.
- The PDF shall await new authorization requests for remaining PDP contexts with updated binding information to remove any media components that were authorized for the terminated early dialogues only. If necessary (i.e. after timeout), the authorization for these PDP contexts shall be revoked as specified in subclause 5.2.1.3.

EXAMPLE: Assume that three forked responses for a certain media component indicate the bandwidths 10 kbps, 30 kbps and 20 kbps, respectively. This media component will first be authorized for 10 kbps and then upgraded to 30 kbps, which will be its final value for the early dialogue phase. If the first final answer corresponds to the third forked, provisional response, then QoS is finally downgraded to 20 kbps.

6 Go protocol

6.1 Protocol support

6.1.1 TCP connection for COPS protocol

The GGSN receives the PDF identifier received as part of the Authorization Token, during the secondary PDP context activation or PDP context modification procedure. The GGSN resolves the PDF IP address from the PDF identifier, which is in the form of a fully qualified domain name.

If there is no existing TCP connection to the PDF, the GGSN shall establish a TCP connection for COPS interactions to the PDF. The GGSN shall use an existing TCP connection to the PDF, whenever present.

The TCP connection between the GGSN and the PDF may be pre-established by configuring the PDF addresses on the GGSN.

All communication between the GGSN and the PDFs shall use a standardised Client-Type with a corresponding standardised PIB, as defined in annex B.

The validity of the PDF may be ensured either by using a private DNS for resolving the PDF IP address or by configuring a list of allowed PDF IP addresses on the GGSN.

6.1.2 COPS protocol

The Go interface allows service-based local policy and QoS inter-working information to be "pushed" to or requested by the GGSN from a PDF.

The COPS protocol supports a client/server interface between the GGSN and the PDF. The Go interface shall conform to the IETF COPS framework as a requirement and guideline for Stage 3 work.

The COPS protocol allows both push and pull operations. For the purpose of the initial authorisation of QoS resources the pull operation shall be used. Subsequently the interactions between the PDF and the GGSN may use either pull or push operations.

Policy decisions may be stored by the COPS client in a local policy decision point allowing the GGSN to make admission control decisions without requiring additional interaction with the PDF.

The COPS client (PEP) can request a policy decision from the PDF triggered by a QoS signalling request. One PEP request may be followed by one or more asynchronous PDF decisions. Each of the decisions will allow the PDF to notify the PEP in the GGSN whenever necessary to change earlier decisions, generate errors etc.

Protocol stack: IP, TCP and COPS.

6.2 Basic COPS events/messages

The Go interface supports event triggered information transfer between the GGSN and PDF

6.2.1 Type of messages

The COPS protocol supports several messages between GGSN and PDF. The message content is dependent on the type of COPS operation (e.g. Client-Open/Client-Accept/Client-Close, Request, Decision and Delete Request State).

The Client Open, Client Accept, Client Close, Keep Alive, Synchronize State Request and Synchronize State Complete messages are used for setting up and maintaining the connection between the PDF and the GGSN.

The following messages supported by the COPS layer for Go interface are used for the policy control operations:

- **Request (REQ)** message from the GGSN to the PDF is used by the GGSN to request SBLP and QoS inter-working information.
- **Decision (DEC)** message from the PDF to the GGSN is a response to the Request message or an asynchronous notification from PDF to the GGSN whenever necessary in order to change earlier decisions, generate errors, etc.
- **Report State (RPT)** message from the GGSN to the PDF is used to communicate the success, failure or changes to the client state of the GGSN in carrying out the PDF's decision indicated in the Decision message.
- **Delete Request State (DRQ)** message from the GGSN to the PDF indicates that the state identified by the client handle is no longer available/relevant and the corresponding state may be removed from the PDF.

6.3 Go events/messages

The UMTS-specific information is carried in specific COPS-PR objects, as defined in the 3GPP Go PIB that is given in annex B.

6.3.1 Event descriptions

The Go Interface uses COPS-PR (RFC 3084 [8]) schematics and the 3GPP Go PIB. For COPS-PR to support the Outsourcing Model it is required to add a new 3GPP Go PIB with objects to:

- Describe the Triggering Event Handling.
- Describe the Outsourcing Event.
- Describe the Decision for the Outsourced Event.
- Describe the Termination of the Outsourced Event.
- Describe the resource used for the Outsourced Event.

6.3.1.1 Common Header, Client Type

The COPS Client-type number for go3gpp is 0x8009 (Client type number assigned by IANA).

6.3.1.2 Context Object

The COPS Context Object is sent in the REQ and DEC messages. This object is used to indicate the triggering event.

C-Num = 2, C-Type = 1

0 1 2 3

R-Type	M-Type
--------	--------

R-Type (Request Type Flag)

0x08 for configuration request

M-Type (Message Type)

0x01 initial capability negotiation

0x02 create event state

0x03 update event state

0x04 terminate event state

6.3.1.3 Client Specific Information (ClientSI) for outsourcing Operation

The binding information consisting of the Authorization Token and flow identifier(s) received by the GGSN are encapsulated inside the Client Specific Information object of the COPS request message sent from the GGSN to the PDF. The PDF identifier is extracted from the token and used inside the GGSN to resolve the address of the actual PDF. However, from the Go message perspective, the token is treated as an opaque entity.

6.3.1.4 Conformance Section

The conformance section indicates the PIB objects, i.e. provisioning classes (PRCs), that a PIB shall have to be conformant to 3GPP Go PIB. To be conformant to the 3GPP Go PIB, it is mandatory to have all the 3GPP Go PIB PRCs and the frwkPrcSupportGroup, frwkDeviceIdGroup included from the Framework PIB ([15]). The supported PRCs are notified using these mandatory groups of PRCs from the Framework PIB.

The following GGSN capabilities are notified to the PDF by indicating the corresponding PRCs:

- Bearer authorisation capabilities:

The GGSN notifies the PDF that it supports bearer authorisation capabilities. The GGSN will provide the token(s) and flow identifier(s) in the REQ for verifying the binding information and the grouping of the media flows by the PDF. The go3gppAuthReqEventGroup together with the go3gppBindingInfoGroup and the go3gppFlowIdGroup are used for this purpose.

Furthermore, the GGSN will enforce any requested or unrequested decision for the authorisation of GPRS and IP resources. If the authorisation at the PDF fails the go3gppAuthReqFailDecGroup is used to give some information on the reason of failure to the GGSN. The go3gppAuthReqDecGroup together with the go3gppAuthReqDirDecGroup are used in case of a successful authorisation at the PDF. This also includes the following capabilities:

- "Authorised QoS" capabilities:

The GGSN notifies the PDF that it is capable to enforce the combined "Authorised QoS" for the bearer. The go3gppQosGroup is used for this purpose.

- Gating capabilities:

The GGSN notifies the PDF that it is capable to enforce the gating functionality. The go3gppGateGroup together with the frwkBaseFilterGroup and the frwkIpFilterGroup are used for this purpose.

- Indication of device capabilities and device limitations:

The GGSN informs the PDF that it is able to notify its device capabilities and device limitations. The go3gppAuthReqCapGroup and the go3gppAuthReqDecCapGroup are used for this purpose.

- Open /close the gate capabilities:

The GGSN informs the PDF that it is capable to enforce a separate decision on opening the gate for the authorised media flow and it is capable to enforce a separate decision from the PDF regarding disabling of the gate. The go3gppGateDecGroup together with the go3gppGateGroup are used for this purpose.

- Revoke media authorisation capabilities:

The GGSN notifies the PDF that it is capable to enforce the revoke authorisation for GPRS and IP resources decision from the PDF. No PRCs are required to indicate this capability.

- Charging co-ordination:

The GGSN informs the PDF that it is capable to send GCID(s) and GGSN address to the PDF. The go3gppReportGroup together with the go3gppRprtGPRSchrgInfoGroup are used for this purpose.

The GGSN informs the PDF that it is capable to receive ICID(s) from the PDF. The go3gppAuthReqDecGroup together with the go3gppIcidGroup are used for this purpose.

- Indication of QoS modifications to 0 kbps and from 0 kbps:

The GGSN informs the PDF that it is able to notify when the maximum bit rate for the PDP context is modified to 0 kbps or that the maximum bit rate for the PDP context is changed from 0 kbps. The go3gppReportGroup together with the go3gppRprtUsageGroup are used for this purpose.

- Indication of bearer release:

The GGSN notifies the PDF that it is capable to notify when the previously authorised GPRS and IP resources are released, i.e. PDP context is deactivated. No PRCs are required to indicate this capability.

- COPS-PR specific capabilities:

The GGSN informs the PDF that it supports the following COPS-PR (RFC 3084 [8]) specific capabilities:

- Outsourcing capability:

The GGSN informs the PDF that it supports the outsourcing model. The go3gppAuthReqHandlerGroup is used for this purpose.

6.3.1.5 Reporting of Device Capabilities and Device Limitations

The functionality of reporting of device capabilities and device limitations is as described in RFC 3084 [8]. In addition, the following shall apply.

The configuration request message serves as a request from the GGSN to the PDF and includes provisioning client information to provide the PDF with client-specific configuration or capability information about the GGSN. The capability information to be exchanged could include additional PIB objects supported by the GGSN which are part of the capability section. If no value information is exchanged then the default value will be used as if it had been exchanged. This information from the client assists the server in deciding what types of policy the GGSN can install and enforce.

The following GGSN capabilities and limitations may be provided in the configuration request message:

- Indication of the maximum number of binding information:
The GGSN may notify the PDF how many binding information the GGSN is able to send with an `Authorization_Request`.
- Indication of the maximum number of Flow identifiers:
The GGSN may notify the PDF how many Flow identifiers the GGSN is able to send with an `Authorization_Request`.
- Indication of the maximum number of ICIDs:
The GGSN may notify the PDF how many ICIDs the GGSN is able to receive with an `Authorization_Decision`.

The device capabilities information exchanged by the initial messages shall be stored in the PDF.

6.3.1.6 Initial Go Policy Provisioning

The functionality of initial Go policy provisioning is as described in RFC 3084 [8]. In addition, the following shall apply:

- The DEC message is sent from the PDF to the GGSN in response to the REQ message received from the GGSN. The Client Handle shall be the same as that received in the corresponding REQ message.
- The DEC message is sent as an immediate response to a configuration request with the solicited message flag set in the COPS message header. The PDF shall also inform the GGSN what types of events shall trigger policy control requests over the Go interface.
- The R-type = 0x08 for configuration request is used here and M-type = 0x01 initial capability negotiation is used here.

6.3.2 Message description

The following messages and events are available on the Go interface (after the initial policy provisioning described in subclause 6.3.1.5):

- `Authorisation_Request (REQ) (GGSN→PDF)`:
This event allows the GGSN to request authorisation data from the PDF. It contains the following information:
 - Client Handle;
 - Binding Information.The R-type = 0x08 for configuration request is used here and M-type = 0x02 create event state is used here.
- `Authorisation_Decision (DEC)(PDF→GGSN)`, contains an `INSTALL` decision:

This event provides the GGSN with the relevant authorisation data. The event contains the following information:

- Client Handle;
- ICID(s) (only in the initial Authorisation_Decision). Only one ICID is transferred in this Release. The form of the ICID is defined in 3GPP TS 32.225 [21];
- Unidirectional set (this parameter shall appear once for each direction (uplink and downlink)):
 - Direction indicator;
 - "Authorised QoS";
 - Gate description (this parameter shall appear once for each required gate for this direction):
 - Filter Specification - The information about the authorised IP end points addresses and ports is detailed below. The Filter Specification parameters are:
 - Source IP address;
 - Destination IP address;
 - Source ports;
 - Destination ports;
 - Protocol ID.

The Source and Destination ports are described with a range consisting of a minimum and maximum value. If only one port is authorised, the minimum value and maximum value of the range are identical.

A filter specification describing more than one IP flow shall be only used in case of identical Protocol IDs, IP addresses and successive port numbers (e.g. RTP and RTCP IP flow of a media component). Furthermore, the gate status of all IP flows described by this filter specification shall be identical, too.

The Base and IP Filter definitions from the IETF Framework PIB [15] shall be used in the 3GPP Go PIB to represent the filter specification. Only a subset of the available filter attributes shall be used. The attributes `frwkIpFilterDscp`, and `frwkIpFilterFlowId` in the filter description shall have their values set to -1, indicating a "match-all" wildcard condition, in effect a "not used" condition. The attribute `frwkBaseFilterNegation` shall have its value set to "false" to indicate not using negation, in effect a "not used" condition. The GGSN shall ignore them if they are set otherwise. Wildcarding of filter elements is detailed in Annex B.

- Gate status (opened/closed)

The R-type = 0x08 for configuration request is used here and M-type = 0x02 create event state is used here.

- Authorisation_Failure (DEC) (PDF→GGSN), contains an INSTALL and a REMOVE decision:

This event provides the GGSN with an indication of an authorisation failure, and may carry additional reason details. The event contains the following information:

- Client Handle;
- Authorisation failure (including any provided reason information).

The R-type = 0x08 for configuration request is used here and M-type = 0x04 terminate event state is used here.

The COPS Decision Flags object 0x02 ("Request-State" flag) shall not be set for the REMOVE decision.

- Gate Decision (DEC) (PDF→GGSN), contains an INSTALL decision:

The Gate Decision indicates to the GGSN the new status of the gate(s) established for a client handle (PDP context). The gate status indicates to the GGSN that the gate shall be opened or closed. Only the gate(s) for which the status is changed are indicated by this event. The event contains the following information:

- Client Handle;
- Unidirectional set (this parameter shall appear once for each direction for which gates are being updated (uplink and/or downlink)):
 - Direction indicator;
 - Gate description (this parameter shall appear once for each gate to be modified for this direction) :
 - Filter Specification - The information about the authorised IP end points addresses and ports is detailed below. The Filter Specification parameters are:
 - Source IP address;
 - Destination IP address;
 - Source ports;
 - Destination ports;
 - Protocol ID.

The Source and Destination ports are described with a range consisting of a minimum and maximum value. If only one port is authorised, the minimum value and maximum value of the range are identical.

A filter specification describing more than one IP flow shall be only used in case of identical Protocol IDs, IP addresses and successive port numbers (e.g. RTP and RTCP IP flow of a media component). Furthermore, the gate status of all IP flows described by this filter specification shall be identical, too.

The Base and IP Filter definitions from the IETF Framework PIB [15] shall be used in the 3GPP Go PIB to represent the filter specification. Only a subset of the available filter attributes shall be used. The attributes `frwkIpFilterDscp`, and `frwkIpFilterFlowId` in the filter description shall have their values set to -1, indicating a "match-all" wildcard condition, in effect a "not used" condition. The attribute `frwkBaseFilterNegation` shall have its value set to "false" to indicate not using negation, in effect a "not used" condition. The GGSN shall ignore them if they are set otherwise. Wildcarding of filter elements is detailed in Annex B.

- Gate status (opened/closed)

NOTE: The opening of the gate may occur at the same time / be part of the authorisation decision event.

The R-type = 0x08 for configuration request is used here and M-type = 0x03 update event state is used here.

- Report (RPT) (GGSN→PDF):

The GGSN sends a COPS RPT message as a response to a decision (DEC) message back to the PDF reporting that it enforced or not the `Authorisation_Decision` or the `Authorization_Failure_Decision` (`Authorization_Report`) or the `Gate_Decision` (`Gate_Report`).

The events contain the following information:

- Client Handle;
- Success / Failure.

In addition, the `Authorization_report` of the initial `Authorisation_Decision` includes:

- GCID;
- GGSN address.

- Report of state changes:

The GGSN sends the report of state change message to the PDF reporting that the maximum bit rate for the PDP context is modified to 0 kbps or that the maximum bit rate for the PDP context is changed from 0 kbps.

The event contains the following information:

- Client Handle;
- Maximum bit rate (set to 0 kbps / changed from 0 kbps).

- Delete Request State (DRQ) (GGSN→PDF):

The GGSN informs the PDF via the delete request state message, that the PDP context is deactivated and the request state identified by the client handle is no longer available/relevant at the GGSN, so the corresponding state shall also be removed at the PDF.

The DRQ message includes the reason why the request state was deleted.

The event contains the following information:

- Client Handle;
- Reason code: value 4:
- Value 4 "Tear": This value is used when the PDP context has been deactivated as a result from normal PDP context signalling handling.
- Value 7 "Insufficient bearer resources": This value is used when the PDP context has been deactivated due to insufficient bearer resources at the GGSN.

- Remove_Decision (DEC) (PDF→GGSN):

The PDF uses the Remove_Decision to inform the GGSN that the PDF revokes the authorized resources for the client handle (PDP context). The Remove_Decision is a specific Decision message with the COPS Decision Flags object set to 0x02 ("Request-State" flag) and the Command-Code set to "REMOVE"; see IETF RFC 3084 [8].

The event contains the following information:

- Client Handle.

The R-type = 0x08 for configuration request is used here and M-type = 0x04 terminate event state is used here.

6.4 Go data

The detailed data description is provided in annex B.

6.5 Security Considerations

The security mechanisms described in COPS (RFC 2748 [7]) and COPS-PR (RFC 3084 [8]) should be re-used in 3GPP.

Annex A:
(Void)

Annex B (normative): 3GPP Go PIB

```

GO3GPP-PIB  PIB-DEFINITIONS ::= BEGIN

IMPORTS
    Unsigned32, Integer32, MODULE-IDENTITY,
    MODULE-COMPLIANCE, OBJECT-TYPE, OBJECT-GROUP
        FROM COPS-PR-SPPI          -- Defined in RFC 3159 [9]
    InstanceId, Prid
        FROM COPS-PR-SPPI-TC      -- Defined in RFC 3159 [9]
    zeroDotZero
        FROM SNMPv2-SMI

    InetAddress, InetAddressType,
    InetAddressPrefixLength
        FROM INET-ADDRESS-MIB;    -- Defined in RFC 3291 [19]

go3gppPib  MODULE-IDENTITY
    SUBJECT-CATEGORIES { go3gpp (0x8009) } -- Go 3GPP COPS Client Type

    LAST-UPDATED "200305240000Z"
    ORGANIZATION "3GPP TSG CN WG3"
    CONTACT-INFO
        "Kwok Ho Chan
        Nortel Networks
        600 Technology Park Drive
        Billerica, MA 01821 USA
        Phone: +1 978 288 8175
        Email: khchan@nortelnetworks.com

        Louis-Nicolas Hamer
        Nortel Networks
        PO Box 3511 Station C
        Ottawa, Ontario
        Canada, K1Y 4H7
        Phone: +1 613 768 3409
        Email: nhamer@nortelnetworks.com"

    DESCRIPTION
        "A PIB module containing the set of provisioning
        classes that are required for support of policies for
        3GPP's GO interface, Release 5."
    REVISION "200305240000Z "
    DESCRIPTION
        "The 3GPP Go PIB for release 5
        Annex B of 3GPP TS 29.207 v5.4.0."

    ::= { 1 3 6 1 4 1 10415 1 1 } -- full specification of object ID tree.
        -- The final syntax should be { 3gpp_pib 1 }
        -- With imports from the document that shows
        -- that 3gpp_pib means ( 1.3.6.1.4.1.10415.1 )

--
-- The root OID for PRCs in the 3GPP GO PIB
--

go3gppCapabilityClasses      OBJECT IDENTIFIER ::= { go3gppPib 1 }
go3gppEventHandlerClasses   OBJECT IDENTIFIER ::= { go3gppPib 2 }
go3gppEventClasses          OBJECT IDENTIFIER ::= { go3gppPib 3 }
go3gppEventInfoClasses      OBJECT IDENTIFIER ::= { go3gppPib 4 }
go3gppReqInfoClasses        OBJECT IDENTIFIER ::= { go3gppEventInfoClasses 1 }
go3gppDecInfoClasses        OBJECT IDENTIFIER ::= { go3gppEventInfoClasses 2 }
go3gppReportClasses         OBJECT IDENTIFIER ::= { go3gppPib 5 }
go3gppConformance          OBJECT IDENTIFIER ::= { go3gppPib 6 }

-- -----
--
-- Capability and Limitation Policy Rule Classes

```



```

--
--
-- 3GPP GO Capability Table
--
go3gppAuthReqCapTable OBJECT-TYPE
    SYNTAX      SEQUENCE OF Go3gppAuthReqCapEntry
    PIB-ACCESS   notify
    STATUS       current
    DESCRIPTION
        "The 3GPP Go Authorization Request Capability PRC."
    ::= { go3gppCapabilityClasses 1 }

go3gppAuthReqCapEntry OBJECT-TYPE
    SYNTAX      Go3gppAuthReqCapEntry
    STATUS       current
    DESCRIPTION
        "An instance of the go3gppAuthReqCap class identifies a
         specific PRC and associated attributes as supported
         by the device."

    PIB-INDEX { go3gppAuthReqCapPrid }
    UNIQUENESS { }
    ::= { go3gppAuthReqCapTable 1 }

Go3gppAuthReqCapEntry ::= SEQUENCE {
    go3gppAuthReqCapPrid      InstanceId,
    go3gppAuthReqCapBindingInfos Unsigned32,
    go3gppAuthReqCapFlowIds   Unsigned32
}

go3gppAuthReqCapPrid OBJECT-TYPE
    SYNTAX      InstanceId
    STATUS       current
    DESCRIPTION
        "An arbitrary integer index that uniquely identifies an
         instance of the go3gppAuthReqCap class."
    ::= { go3gppAuthReqCapEntry 1 }

go3gppAuthReqCapBindingInfos OBJECT-TYPE
    SYNTAX      Unsigned32
    STATUS       current
    DESCRIPTION
        "Indication of the maximum number of Binding Information
         the PEP can send with each Authorization Request.
         The value of zero indicates limit is not specified."
    DEFVAL { 0 }
    ::= { go3gppAuthReqCapEntry 2 }

go3gppAuthReqCapFlowIds OBJECT-TYPE
    SYNTAX      Unsigned32
    STATUS       current
    DESCRIPTION
        "Indication of the maximum number of Flow identifiers the PEP can
         send with each Authorization Request.
         The value of zero indicates limit is not specified."
    DEFVAL { 0 }
    ::= { go3gppAuthReqCapEntry 3 }

--
-- Go 3GPP Authorization Request Decision Capabilities
--
go3gppAuthReqDecCapTable OBJECT-TYPE
    SYNTAX      SEQUENCE OF Go3gppAuthReqDecCapEntry
    PIB-ACCESS   notify
    STATUS       current
    DESCRIPTION
        "The 3GPP Go Authorization Request Decision Capability PRC."
    ::= { go3gppCapabilityClasses 2 }

```

```

go3gppAuthReqDecCapEntry OBJECT-TYPE
    SYNTAX      Go3gppAuthReqDecCapEntry
    STATUS      current
    DESCRIPTION
        "An instance of the go3gppAuthReqDecCap class identifies a
        specific PRC and associated attributes as supported
        by the device."

    PIB-INDEX { go3gppAuthReqDecCapPrid }
    UNIQUENESS { }
    ::= { go3gppAuthReqDecCapTable 1 }

Go3gppAuthReqDecCapEntry ::= SEQUENCE {
    go3gppAuthReqDecCapPrid      InstanceId,
    go3gppAuthReqDecCapIcids     Unsigned32
}

go3gppAuthReqDecCapPrid OBJECT-TYPE
    SYNTAX      InstanceId
    STATUS      current
    DESCRIPTION
        "An arbitrary integer index that uniquely identifies an
        instance of the go3gppAuthReqDecCap class."
    ::= { go3gppAuthReqDecCapEntry 1 }

go3gppAuthReqDecCapIcids OBJECT-TYPE
    SYNTAX      Unsigned32
    STATUS      current
    DESCRIPTION
        "Indication of the maximum number of Icid possible
        in a single Authorization Request Decision.
        The value of zero indicates limit is not specified."
    DEFVAL     { 0 }
    ::= { go3gppAuthReqDecCapEntry 2 }

--
-- Component Limitations Table
--
-- This table supports the ability to export information
-- detailing provisioning class/attribute implementation limitations
-- to the policy decision function. This Component Limitations Table
-- shall be implementation dependant and does not need to be standardized.

-- -----
--
-- 3GPP GO Event Handler Provisioning Classes
--
-- PRCs sent from PDF to PEP for indicating how to handle each
-- kind of event that require actions by the GO interface.
--
-- For 3GPP Release 5, PRCs for Event Handling of Authorization
-- Request containing Binding Information, Flow identifiers, and QoS is
-- specified.
--
--
-- 3GPP GO Authorization Request Event Handler Provisioning Table
--

go3gppAuthReqHandlerTable OBJECT-TYPE
    SYNTAX      SEQUENCE OF Go3gppAuthReqHandlerEntry
    PIB-ACCESS  install
    STATUS      current
    DESCRIPTION
        "PRC from PDF to PEP carried by COPS DEC messages
        indicating GO actions to take at the GGSN when an Authorization
        Request Event is detected by the GGSN. An example of an
        Authorization Request Event is the receive of a PDP Context message."
    ::= { go3gppEventHandlerClasses 1 }

go3gppAuthReqHandlerEntry OBJECT-TYPE

```

```

SYNTAX          Go3gppAuthReqHandlerEntry
STATUS          current
DESCRIPTION
  "An instance of the go3gppAuthReqHandler class sent by the PDF to
  the PEP what the PEP should send upon detection of an Authorization
  Request Event."
PIB-INDEX { go3gppAuthReqHandlerPrid }
UNIQUENESS { go3gppAuthReqHandlerEnable,
              go3gppAuthReqHandlerBindingInfo
            }
 ::= { go3gppAuthReqHandlerTable 1 }

```

```

Go3gppAuthReqHandlerEntry ::= SEQUENCE {
  go3gppAuthReqHandlerPrid      InstanceId,
  go3gppAuthReqHandlerEnable    INTEGER,
  go3gppAuthReqHandlerBindingInfo Unsigned32
}

```

```

go3gppAuthReqHandlerPrid OBJECT-TYPE
SYNTAX          InstanceId
STATUS          current
DESCRIPTION
  "An arbitrary integer index that uniquely identifies an
  instance of this class."
 ::= { go3gppAuthReqHandlerEntry 1 }

```

```

go3gppAuthReqHandlerEnable OBJECT-TYPE
SYNTAX          INTEGER {
                  enable(1),
                  disable(2)
                }
STATUS          current
DESCRIPTION
  "Controls the usage of 3GPP Authorization Request Events
  to trigger COPS requests to PDF on the go interface."
DEFVAL { enable }
 ::= { go3gppAuthReqHandlerEntry 2 }

```

```

go3gppAuthReqHandlerBindingInfo OBJECT-TYPE
SYNTAX          Unsigned32
STATUS          current
DESCRIPTION
  "Indication of the maximum number of Binding Information
  be associated with a each Authorizing Request.
  The value of zero indicates policy control does not impose
  any limit."
DEFVAL { 0 }
 ::= { go3gppAuthReqHandlerEntry 3 }

```

```

-- -----
--
-- 3GPP GO Event Classes
--
-- PRCs from PEP to PDF carried by COPS REQ messages
-- indicating the detection of specific events in the GGSN.
-- Information required for PDF to make decision on behave
-- of GGSN is also defined here to be carried by REQ messages.
--
--
-- 3GPP GO Authorization Request Event Table
--
go3gppAuthReqEventTable OBJECT-TYPE
SYNTAX          SEQUENCE OF Go3gppAuthReqEventEntry
PIB-ACCESS      notify
STATUS          current
DESCRIPTION
  "PRC for indication of Authorization Request Event
  and its relevant information.
  Sent by PEP to PDF upon receive of an Authorization
  Request. Using COPS REQ message."
 ::= { go3gppEventClasses 1 }

```

```

go3gppAuthReqEventEntry OBJECT-TYPE
    SYNTAX          Go3gppAuthReqEventEntry
    STATUS          current
    DESCRIPTION
        "An entry in the Authorization Request Event Table
        describe a single Event sent by the PEP to the PDF."
    PIB-INDEX { go3gppAuthReqEventPrid }
    UNIQUENESS { }
    ::= { go3gppAuthReqEventTable 1 }

Go3gppAuthReqEventEntry ::= SEQUENCE {
    go3gppAuthReqEventPrid      InstanceId,
    go3gppAuthReqEventBindingInfos Prid
}

go3gppAuthReqEventPrid OBJECT-TYPE
    SYNTAX          InstanceId
    STATUS          current
    DESCRIPTION
        "An arbitrary integer index that uniquely identifies an
        instance of the go3gppAuthReqEvent class."
    ::= { go3gppAuthReqEventEntry 1 }

go3gppAuthReqEventBindingInfos OBJECT-TYPE
    SYNTAX          Prid
    STATUS          current
    DESCRIPTION
        "References the first of a list of go3gppBindingInfo
        class instances that are associated with this
        Authorization Request Event.
        A value of zeroDotZero indicates there are no
        go3gppBindingInfo class instance associated with
        this Authorization Event."
    ::= { go3gppAuthReqEventEntry 2 }

--
-- 3GPP Go Event Request Info Classes
--
--
-- 3GPP GO Binding Information Table
--
go3gppBindingInfoTable OBJECT-TYPE
    SYNTAX          SEQUENCE OF Go3gppBindingInfoEntry
    PIB-ACCESS      notify
    STATUS          current
    DESCRIPTION
        "PRC representing Binding Information.
        Sent by PEP to PDF as part of an Authorization
        Request. In a COPS REQ message."
    ::= { go3gppReqInfoClasses 1 }

go3gppBindingInfoEntry OBJECT-TYPE
    SYNTAX          Go3gppBindingInfoEntry
    STATUS          current
    DESCRIPTION
        "An entry in the Binding Information Table
        describing a single Binding Info.
        Each entry is referenced by go3gppAuthReqEventBindingInfos
        or go3gppBindingInfoNext."
    PIB-INDEX { go3gppBindingInfoPrid }
    UNIQUENESS { }
    ::= { go3gppBindingInfoTable 1 }

Go3gppBindingInfoEntry ::= SEQUENCE {
    go3gppBindingInfoPrid      InstanceId,
    go3gppBindingInfoToken     OCTET STRING,
    go3gppBindingInfoFlowIds   Prid,
    go3gppBindingInfoNext     Prid
}

```

```

go3gppBindingInfoPrid OBJECT-TYPE
    SYNTAX      InstanceId
    STATUS      current
    DESCRIPTION
        "An arbitrary integer index that uniquely identifies an
        instance of the go3gppBindingInfo class."
    ::= { go3gppBindingInfoEntry 1 }

```

```

go3gppBindingInfoToken OBJECT-TYPE
    SYNTAX      OCTET STRING
    STATUS      current
    DESCRIPTION
        "The Authorization Token associated with this
        instance of the go3gppBindingInfo class.
        Each Binding Information must have a Token."
    ::= { go3gppBindingInfoEntry 2 }

```

```

go3gppBindingInfoFlowIds OBJECT-TYPE
    SYNTAX      Prid
    STATUS      current
    DESCRIPTION
        "References the first of a list of FlowIds associated
        with this instance of go3gppBindingInfo class.
        This is the anchor of a list of go3gppFlowIdEntry
        Instances.
        A value of zeroDotZero indicates an empty list which
        is an error condition."
    DEFVAL { zeroDotZero }
    ::= { go3gppBindingInfoEntry 3 }

```

```

go3gppBindingInfoNext OBJECT-TYPE
    SYNTAX      Prid
    STATUS      current
    DESCRIPTION
        "References the next of a list of go3gppBindingInfo
        instances associated with an Authorization Request.
        A value of zeroDotZero indicates this is the last of
        a list of go3gppBindingInfo instances associated with
        an Authorization Request."
    DEFVAL { zeroDotZero }
    ::= { go3gppBindingInfoEntry 4 }

```

```

--
-- 3GPP Go Authorization Request FlowID Table
--

```

```

go3gppFlowIdTable OBJECT-TYPE
    SYNTAX      SEQUENCE OF Go3gppFlowIdEntry
    PIB-ACCESS  notify
    STATUS      current
    DESCRIPTION
        "Represents the collection of FlowIDs."
    ::= { go3gppReqInfoClasses 2 }

```

```

go3gppFlowIdEntry OBJECT-TYPE
    SYNTAX      Go3gppFlowIdEntry
    STATUS      current
    DESCRIPTION
        "Each entry describes a single FlowID."
    PIB-INDEX { go3gppFlowIdPrid }
    UNIQUENESS { }
    ::= { go3gppFlowIdTable 1 }

```

```

Go3gppFlowIdEntry ::= SEQUENCE {
    go3gppFlowIdPrid      InstanceId,
    go3gppFlowIdFlowId   Unsigned32,
    go3gppFlowIdNext     Prid
}

```

```

go3gppFlowIdPrid OBJECT-TYPE

```

```

SYNTAX      InstanceId
STATUS      current
DESCRIPTION
  "An arbitrary integer index that uniquely identifies an
  instance of the go3gppFlowId class."
 ::= { go3gppFlowIdEntry 1 }

```

```

go3gppFlowIdFlowId OBJECT-TYPE
SYNTAX      Unsigned32
STATUS      current
DESCRIPTION
  "The FlowId itself."
 ::= { go3gppFlowIdEntry 2 }

```

```

go3gppFlowIdNext OBJECT-TYPE
SYNTAX      Prid
STATUS      current
DESCRIPTION
  "References the next FlowId in the list associated with the
  same Binding Information of an Authorization Request.
  This points to a list of go3gppFlowIdEntry Instances.
  A value of zeroDotZero indicates end of the list."
DEFVAL     { zeroDotZero }
 ::= { go3gppFlowIdEntry 3 }

```

```

-----
--
-- 3GPP Go Authorization Request Decisions
--
-- PRCs for carrying the Event Decision send from PDF to PEP,
-- carried by the COPS DEC message.
-- These PRCs include support for Gates/Filters, QoS, ICIDs.
--
--
-- Failure Decisions can be defined by use of COPS-PR DEC message
-- containing first an install decision (with objects indicating
-- what failed and some indication to the GGSN how to react to this
-- Error Decision), and second a remove decision (for cleanup of
-- the installed Error Decision Object).
--
--
-- Failures indicated by PDF to GGSN
--   Authorization Failure
--
--
-- Authorization Request Failure Decision Table
--
go3gppAuthReqFailDecTable OBJECT-TYPE
SYNTAX      SEQUENCE OF Go3gppAuthReqFailDecEntry
PIB-ACCESS  install
STATUS      current
DESCRIPTION
  "The Authorization failure Table. Indicates failures decisions to the PEP."
 ::= { go3gppDecInfoClasses 1 }

go3gppAuthReqFailDecEntry OBJECT-TYPE
SYNTAX      Go3gppAuthReqFailDecEntry
STATUS      current
DESCRIPTION
  "Each go3gppAuthReqFailDecEntry is per request."
PIB-INDEX  { go3gppAuthReqFailDecPrid }
UNIQUENESS { }
 ::= { go3gppAuthReqFailDecTable 1 }

Go3gppAuthReqFailDecEntry ::= SEQUENCE {
    go3gppAuthReqFailDecPrid      InstanceId,

    go3gppAuthReqFailDecReason    INTEGER
}

go3gppAuthReqFailDecPrid OBJECT-TYPE

```

```

SYNTAX      InstanceId
STATUS      current
DESCRIPTION
  "An arbitrary integer index that uniquely identifies an
  instance of the go3gppAuthReqFailDec class."
 ::= { go3gppAuthReqFailDecEntry 1 }

```

```
go3gppAuthReqFailDecReason OBJECT-TYPE
```

```

SYNTAX      INTEGER {
                noCorrespondingSession (1),
                invalidBundling (2),
                authorizationFailure (3)
            }
STATUS      current
DESCRIPTION
  "Reason for Auth Request Failure Decision given by PDF:

  noCorrespondingSession:      No corresponding session was found
                                by the PDF

  invalidBundling:             In case the UE violates the AF level indication
                                and attempts to set up multiple AF media components
                                in a single PDP context despite of an indication that
                                mandated separate PDP contexts or if the list
                                of flowidentifiers contained in the bearer authorization
                                request doesn't match with the grouping indication
                                information the PDF has received from the AF.

  authorizationFailure:        The PDF is unable to authorise the binding information.
                                This is a generic failure indication that can be used
                                if the actual reason is not any of the other specified
                                reasons."
 ::= { go3gppAuthReqFailDecEntry 2 }

```

```

--
-- Authorization Request Decision Table
--

```

```
go3gppAuthReqDecTable OBJECT-TYPE
```

```

SYNTAX      SEQUENCE OF Go3gppAuthReqDecEntry
PIB-ACCESS  install
STATUS      current
DESCRIPTION
  "The Authorization Request Decision Table. "
 ::= { go3gppDecInfoClasses 2 }

```

```
go3gppAuthReqDecEntry OBJECT-TYPE
```

```

SYNTAX      Go3gppAuthReqDecEntry
STATUS      current
DESCRIPTION
  "Each go3gppAuthReqDecEntry is per Authorization Request."
PIB-INDEX  { go3gppAuthReqDecPrid }
UNIQUENESS { }
 ::= { go3gppAuthReqDecTable 1 }

```

```

Go3gppAuthReqDecEntry ::= SEQUENCE {
    go3gppAuthReqDecPrid      InstanceId,
    go3gppAuthReqDecIcids     Prid,
    go3gppAuthReqDecDirDecs   Prid
}

```

```
go3gppAuthReqDecPrid OBJECT-TYPE
```

```

SYNTAX      InstanceId
STATUS      current
DESCRIPTION
  "An arbitrary integer index that uniquely identifies an
  instance of the go3gppAuthReqDec class."
 ::= { go3gppAuthReqDecEntry 1 }

```

```
go3gppAuthReqDecIcids OBJECT-TYPE
```

```

SYNTAX      Prid

```

```

STATUS          current
DESCRIPTION
  "References the first of a list of IcIDs associated
  with this instance of go3gppAuthReqDec class.
  There should be one IcID on this list for each Binding
  Information in the corresponding Authorization Request.
  A value of zeroDotZero indicates an empty list and there
  is no IcID change associated with this Authorization Request
  Decision."
DEFVAL { zeroDotZero }
 ::= { go3gppAuthReqDecEntry 2 }

```

```

go3gppAuthReqDecDirDecs OBJECT-TYPE
SYNTAX          Prid
STATUS          current
DESCRIPTION
  "References the first of a list of Directional Decisions
  associated with this instance of go3gppAuthReqDec class.
  There should be at least one and at most two Directional
  Decisions per Authorization Request Decision.
  Hence a value of zeroDotZero is illegal."
 ::= { go3gppAuthReqDecEntry 3 }

```

```

--
-- 3GPP Go ICID Table
--

```

```

go3gppIcidTable OBJECT-TYPE
SYNTAX          SEQUENCE OF Go3gppIcidEntry
PIB-ACCESS      install
STATUS          current
DESCRIPTION
  "Represents the collection of ICID entries"
 ::= { go3gppDecInfoClasses 3 }

```

```

go3gppIcidEntry OBJECT-TYPE
SYNTAX          Go3gppIcidEntry
STATUS          current
DESCRIPTION
  "Represents the ICID Entry"
PIB-INDEX { go3gppIcidPrid }
UNIQUENESS { go3gppIcidValue }
 ::= { go3gppIcidTable 1 }

```

```

Go3gppIcidEntry ::= SEQUENCE {
    go3gppIcidPrid      InstanceId,
    go3gppIcidValue    OCTET STRING,
    go3gppIcidNext     Prid
}

```

```

go3gppIcidPrid OBJECT-TYPE
SYNTAX          InstanceId
STATUS          current
DESCRIPTION
  "An arbitrary integer index that uniquely identifies an
  instance of the go3gppIcid class."
 ::= { go3gppIcidEntry 1 }

```

```

go3gppIcidValue OBJECT-TYPE
SYNTAX          OCTET STRING
STATUS          current
DESCRIPTION
  "The ICID itself. "
 ::= { go3gppIcidEntry 2 }

```

```

go3gppIcidNext OBJECT-TYPE
SYNTAX          Prid
STATUS          current
DESCRIPTION
  "References the next go3gppIcidEntry of a list of ICIDs
  associated with this instance of go3gppAuthReqDec class.
  There should be one ICID on this list for each Binding

```

Information in the corresponding Authorization Request.
 A value of zeroDotZero indicates the end of the list of
 ICIDs associated with an Authorization Request Decision."
 DEFVAL { zeroDotZero }
 ::= { go3gppIcidEntry 3 }

```
--
-- 3GPP Go Authorization Request Directional Decision Table
--
go3gppAuthReqDirDecTable OBJECT-TYPE
    SYNTAX          SEQUENCE OF Go3gppAuthReqDirDecEntry
    PIB-ACCESS      install
    STATUS          current
    DESCRIPTION
        "This table represents the authorization request decision for
        unique direction (e.g. uplink and downlink)."  

    ::= { go3gppDecInfoClasses 4 }

go3gppAuthReqDirDecEntry OBJECT-TYPE
    SYNTAX          Go3gppAuthReqDirDecEntry
    STATUS          current
    DESCRIPTION
        "There should be one of these per direction per AuthReqDec."  

    PIB-INDEX { go3gppAuthReqDirDecPrid }
    UNIQUENESS { }
    ::= { go3gppAuthReqDirDecTable 1 }

Go3gppAuthReqDirDecEntry ::= SEQUENCE {
    go3gppAuthReqDirDecPrid      InstanceId,
    go3gppAuthReqDirDecDirection INTEGER,
    go3gppAuthReqDirDecQos      Prid,
    go3gppAuthReqDirDecGates    Prid,
    go3gppAuthReqDirDecNext     Prid
}

go3gppAuthReqDirDecPrid OBJECT-TYPE
    SYNTAX          InstanceId
    STATUS          current
    DESCRIPTION
        "An arbitrary integer index that uniquely identifies an
        instance of the go3gppAuthReqDirDec class."  

    ::= { go3gppAuthReqDirDecEntry 1 }

go3gppAuthReqDirDecDirection OBJECT-TYPE
    SYNTAX          INTEGER {
                uplink (1),
                downlink (2)
            }
    STATUS          current
    DESCRIPTION
        "Indicates the direction this decision applies to."  

    ::= { go3gppAuthReqDirDecEntry 2 }

go3gppAuthReqDirDecQos OBJECT-TYPE
    SYNTAX          Prid
    STATUS          current
    DESCRIPTION
        " The Authorized QoS. References the go3gppQos class."  

    ::= { go3gppAuthReqDirDecEntry 3 }

go3gppAuthReqDirDecGates OBJECT-TYPE
    SYNTAX          Prid
    STATUS          current
    DESCRIPTION
        "References the first instance of a list of the go3gppGate class."  

    ::= { go3gppAuthReqDirDecEntry 4 }

go3gppAuthReqDirDecNext OBJECT-TYPE
    SYNTAX          Prid
    STATUS          current
```

```

DESCRIPTION
  "References the next instance of a list of
  go3gppAuthReqDirDec class."
 ::= { go3gppAuthReqDirDecEntry 5 }

--
-- 3GPP Go QoS Table
--
go3gppQoSTable OBJECT-TYPE
  SYNTAX      SEQUENCE OF Go3gppQoSEntry
  PIB-ACCESS  install
  STATUS      current
  DESCRIPTION
    "This table represents the Authorised QoS.
    It is referenced by the go3gppAuthReqDirDecQoS entry of the
    go3gppAuthReqDirDecEntry class."
 ::= { go3gppDecInfoClasses 5 }

go3gppQoSEntry OBJECT-TYPE
  SYNTAX      Go3gppQoSEntry
  STATUS      current
  DESCRIPTION
    "There should be one of these per direction per AuthReqDec."
  PIB-INDEX  { go3gppQoSPrId }
  UNIQUENESS { }
 ::= { go3gppQoSTable 1 }

Go3gppQoSEntry ::= SEQUENCE {
    go3gppQoSPrId          InstanceId,
    go3gppQoSServiceClass INTEGER,
    go3gppQoSDataRateUnit INTEGER,
    go3gppQoSDataRate     Unsigned32
}

go3gppQoSPrId OBJECT-TYPE
  SYNTAX      InstanceId
  STATUS      current
  DESCRIPTION
    "An arbitrary integer index that uniquely identifies an
    instance of the go3gppQoS class."
 ::= { go3gppQoSEntry 1 }

go3gppQoSServiceClass OBJECT-TYPE
  SYNTAX      INTEGER {
        qosclassA (1),
        qosclassB (2),
        qosclassC (3),
        qosclassD (4),
        qosclassE (5),
        qosclassF (6)
      }
  STATUS      current
  DESCRIPTION
    "The QoS Service Class indicates the highest authorized QoS class."
 ::= { go3gppQoSEntry 2 }

go3gppQoSDataRateUnit OBJECT-TYPE
  SYNTAX      INTEGER {
        bps (1),
        kbps (2),
        mbps (3)
      }
  STATUS      current
  DESCRIPTION
    "Indication of the unit of measure for go3gppQoSDataRate,
    in bits per second, kilo bits per second, or mega bits per
    second."
 ::= { go3gppQoSEntry 3 }

```

```

go3gppQosDataRate OBJECT-TYPE
    SYNTAX      Unsigned32
    STATUS      current
    DESCRIPTION
        "The Data Rate with unit of measure indicated by
        go3gppQosDataRateUnit."
    ::= { go3gppQosEntry 4 }

--
-- 3GPP Go Gate Decision Table
--
--
-- There could be one of these per direction per GateDec.
--
-- This is for changing Gating Status only when used alone
-- (not as part of Direction Decision).

-- go3gppGateDec is sent in a different COPS DEC message
-- from the DEC message carrying go3gppAuthReqDec. PDF must
-- have sent a go3gppAuthReqDec before using go3gppGateDec.

go3gppGateDecTable OBJECT-TYPE
    SYNTAX      SEQUENCE OF Go3gppGateDecEntry
    PIB-ACCESS  install
    STATUS      current
    DESCRIPTION
        "This table represents an updated gating decision."
    ::= { go3gppDecInfoClasses 6 }

go3gppGateDecEntry OBJECT-TYPE
    SYNTAX      Go3gppGateDecEntry
    STATUS      current
    DESCRIPTION
        "There should be one of these per direction per AuthReqDec."
    PIB-INDEX { go3gppGateDecPrid }
    UNIQUENESS { }
    ::= { go3gppGateDecTable 1 }

Go3gppGateDecEntry ::= SEQUENCE {
    go3gppGateDecPrid      InstanceId,
    go3gppGateDecDirection INTEGER,
    go3gppGateDecGates     Prid,
    go3gppGateDecNext      Prid
}

go3gppGateDecPrid OBJECT-TYPE
    SYNTAX      InstanceId
    STATUS      current
    DESCRIPTION
        "An arbitrary integer index that uniquely identifies an
        instance of the go3gppGateDec class."
    ::= { go3gppGateDecEntry 1 }

go3gppGateDecDirection OBJECT-TYPE
    SYNTAX      INTEGER {
        uplink (1),
        downlink (2)
    }
    STATUS      current
    DESCRIPTION
        "References the gate direction."
    ::= { go3gppGateDecEntry 2 }

go3gppGateDecGates OBJECT-TYPE
    SYNTAX      Prid
    STATUS      current
    DESCRIPTION
        "References the first instance of a list of go3gppGate class."
    ::= { go3gppGateDecEntry 3 }

```

```

go3gppGateDecNext OBJECT-TYPE
    SYNTAX      Prid
    STATUS      current
    DESCRIPTION
        "References the next instance of a list of go3gppGateDec class."
    ::= { go3gppGateDecEntry 4 }

--
-- 3GPP Go Gate Table
--
go3gppGateTable OBJECT-TYPE
    SYNTAX      SEQUENCE OF Go3gppGateEntry
    PIB-ACCESS  install
    STATUS      current
    DESCRIPTION
        "PRC representing a Gate."
    ::= { go3gppDecInfoClasses 7 }

go3gppGateEntry OBJECT-TYPE
    SYNTAX      Go3gppGateEntry
    STATUS      current
    DESCRIPTION
        "Each instance represents one Gate."
    PIB-INDEX { go3gppGatePrid }
    UNIQUENESS { }
    ::= { go3gppGateTable 1 }

Go3gppGateEntry ::= SEQUENCE {
    go3gppGatePrid      InstanceId,
    go3gppGateFilter    Prid,
    go3gppGateStatus    INTEGER,
    go3gppGateNext     Prid
}

go3gppGatePrid OBJECT-TYPE
    SYNTAX      InstanceId
    STATUS      current
    DESCRIPTION
        "An arbitrary integer index that uniquely identifies an
        instance of the go3gppGate class."
    ::= { go3gppGateEntry 1 }

go3gppGateFilter OBJECT-TYPE
    SYNTAX      Prid
    STATUS      current
    DESCRIPTION
        "References an entry in frwkIpFilterTable (Framework PIB)
        that describes the applicable classification filter.

        When a decision requiring the definition of an IP filter
        is sent to the GGSN, the IP filter will be represented by the
        IP filter definition frwkIpFilterTable, provided by the
        Framework PIB, RFC 3318. Such IP filter frwkIpFilterTable
        must be part of the same decision message. The attribute
        go3gppGateFilter is used to reference the frwkIpFilterTable
        entry for this Gate.

        Wildcarding of the attributes for deriving the address and protocol values
        is as specified in RFC 3318 [15]. Wildcarding of the source ports is achieved as follows:
        - frwkIpFilterSrcL4PortMin shall be set to 0,
        - and frwkIpFilterSrcL4PortMax shall be set to 65535

        The frwkBaseFilterNegation attribute of the frwkBaseFilterTable is
        not required, its "not-used" condition is indicated by setting its
        value to "false".

        The frwkIpFilterDscp and frwkIpFilterFlowId attributes
        of the frwkIpFilterTable are not required, their "not-used" condition is
        indicated by setting their values to -1."

```

A value of zeroDotZero indicates no filter is used with this go3gppGate."
 ::= { go3gppGateEntry 2 }

go3gppGateStatus OBJECT-TYPE

SYNTAX INTEGER {
 close (1),
 open (2)
 }

STATUS current

DESCRIPTION

"Indicates if this gate will allow traffic to flow."

DEFVAL { close }

::= { go3gppGateEntry 3 }

go3gppGateNext OBJECT-TYPE

SYNTAX Prid

STATUS current

DESCRIPTION

"Reference the next Gate on a list of go3gppGate instances.

A value of zeroDotZero indicates this is the last Gate

on the list."

::= { go3gppGateEntry 4 }

```
-----
--
-- 3GPP Go Reports
--
-- PRCs for carrying the Decision enforcement result sent from PEP to PDF,
-- carried using the COPS REPORT message.
-- These PRCs include support for the success or failure of the PEP in
-- carrying out the PDF's decision or -change of the state in the GGSN.
--
```

go3gppReportTable OBJECT-TYPE

SYNTAX SEQUENCE OF Go3gppReportEntry

PIB-ACCESS notify

STATUS current

DESCRIPTION

"This table represents the success or failure of the decision enforcement and state changes in the PEP."

::= { go3gppReportClasses 1 }

go3gppReportEntry OBJECT-TYPE

SYNTAX Go3gppReportEntry

STATUS current

DESCRIPTION

" "

PIB-INDEX { go3gppReportPrid }

UNIQUENESS { }

::= { go3gppReportTable 1 }

```
Go3gppReportEntry ::= SEQUENCE {
    go3gppReportPrid      InstanceId,
    go3gppReportStatus   INTEGER,
    go3gppReportDetails  Prid
}
```

go3gppReportPrid OBJECT-TYPE

SYNTAX InstanceId

STATUS current

DESCRIPTION

"An arbitrary integer index that uniquely identifies an instance of the go3gppReport class."

::= { go3gppReportEntry 1 }

go3gppReportStatus OBJECT-TYPE

SYNTAX INTEGER {
 success (1),
 failure (2),
 usage (3) }

STATUS current

DESCRIPTION

"When Status is:

- success: Indicates the successful implementation of the decision.
 - go3gppReportDetails: Reference an instance of go3gppRprtGPRSchrgInfo for initial authorization request decision; References nothing otherwise (contains the value zeroDotZero).
- Failure: Indicates the failure of implementing the decision.
 - go3gppReportDetails may references an Error object, or may have the value zeroDotZero when no error object is needed, in which case COPS and COPS-PR error codes and error objects are sufficient.
- Usage: go3gppReportDetails references an instance of go3gppRprtUsage class."

```
::= { go3gppReportEntry 2 }
```

go3gppReportDetails OBJECT-TYPE

SYNTAX Prid

STATUS current

DESCRIPTION

"May reference an instance of go3gppRprtGPRSchrgInfo, go3gppRprtError(not defined), or go3gppRprtUsage class, or may have the value of zeroDotZero depending on the value of go3gppReportStatus."

```
::= { go3gppReportEntry 3 }
```

go3gppRprtGPRSchrgInfoTable OBJECT-TYPE

SYNTAX SEQUENCE OF Go3gppRprtGPRSchrgInfoEntry

PIB-ACCESS notify

STATUS current

DESCRIPTION

"This table represents the GPRS Charging information"

```
::= { go3gppReportClasses 2 }
```

go3gppRprtGPRSchrgInfoEntry OBJECT-TYPE

SYNTAX Go3gppRprtGPRSchrgInfoEntry

STATUS current

DESCRIPTION

"This entry represents the GPRS Charging Identifier and GGSN address."

PIB-INDEX { go3gppRprtGPRSchrgInfoPrid }

UNIQUENESS { go3gppRprtGPRSchrgInfoAddrType,
go3gppRprtGPRSchrgInfoGGSNAddr,
go3gppRprtGPRSchrgInfoGCID }

```
::= { go3gppRprtGPRSchrgInfoTable 1 }
```

Go3gppRprtGPRSchrgInfoEntry ::= SEQUENCE {

go3gppRprtGPRSchrgInfoPrid InstanceId,

go3gppRprtGPRSchrgInfoAddrType InetAddressType,

go3gppRprtGPRSchrgInfoGGSNAddr InetAddress,

go3gppRprtGPRSchrgInfoGCID OCTET STRING

}

go3gppRprtGPRSchrgInfoPrid OBJECT-TYPE

SYNTAX InstanceId

STATUS current

DESCRIPTION

"An arbitrary integer index that uniquely identifies an instance of the go3gppRprtGPRSchrgInfo class."

```
::= { go3gppRprtGPRSchrgInfoEntry 1 }
```

go3gppRprtGPRSchrgInfoAddrType OBJECT-TYPE

SYNTAX InetAddressType

STATUS current

DESCRIPTION

"The address type enumeration value to specify the type of the packet's IP address."

REFERENCE

```

    "Textual Conventions for Internet Network Addresses [INETADDR]."
    ::= { go3gppRprtGPRSChrgInfoEntry 2 }

go3gppRprtGPRSChrgInfoGGSNAddr OBJECT-TYPE
    SYNTAX      InetAddress
    STATUS      current
    DESCRIPTION
        "Contains the IP Address of the GGSN providing the GCID
        upon successful handling of an Authorization Request."
    REFERENCE
        "Textual Conventions for Internet Network Addresses [INETADDR]."
        ::= { go3gppRprtGPRSChrgInfoEntry 3 }

go3gppRprtGPRSChrgInfoGCID OBJECT-TYPE
    SYNTAX      OCTET STRING
    STATUS      current
    DESCRIPTION
        "The GPRS Charging ID related to this Authorization Request."
    ::= { go3gppRprtGPRSChrgInfoEntry 4 }

--
-- Notice go3gppRprtError PRC is currently not defined because all
-- error condition handling is satisfactorily covered by using the
-- standard COPS-PR error handling mechanism and error objects.
-- go3gppRprtError PRC should only be used for 3GPP GO Application
-- error indications if necessary.
--

go3gppRprtUsageTable OBJECT-TYPE
    SYNTAX      SEQUENCE OF Go3gppRprtUsageEntry
    PIB-ACCESS  notify
    STATUS      current
    DESCRIPTION
        ""
    ::= { go3gppReportClasses 3 }

go3gppRprtUsageEntry OBJECT-TYPE
    SYNTAX      Go3gppRprtUsageEntry
    STATUS      current
    DESCRIPTION
        "This entry represents the PEP state changes."
    PIB-INDEX  { go3gppRprtUsagePrid }
    UNIQUENESS { go3gppRprtUsageIndication }
    ::= { go3gppRprtUsageTable 1 }

Go3gppRprtUsageEntry ::= SEQUENCE {
    go3gppRprtUsagePrid      InstanceId,
    go3gppRprtUsageIndication INTEGER
}

go3gppRprtUsagePrid OBJECT-TYPE
    SYNTAX      InstanceId
    STATUS      current
    DESCRIPTION
        "An arbitrary integer index that uniquely identifies an
        instance of the go3gppRprtUsage class."
    ::= { go3gppRprtUsageEntry 1 }

go3gppRprtUsageIndication OBJECT-TYPE
    SYNTAX      INTEGER {
        chngdTo0kbs (1),
        chngdFrom0kbs (2) }
    STATUS      current
    DESCRIPTION
        "Indication of GPRS Usage change.
        chngdTo0kbs indicates changing to 0kbs,
        chngdFrom0kbs indicates changing from 0kbs."
    ::= { go3gppRprtUsageEntry 2 }

```

```

--
-- Conformance Section
--

go3gppCompliances          OBJECT IDENTIFIER ::= { go3gppConformance 1 }
go3gppGroups               OBJECT IDENTIFIER ::= { go3gppConformance 2 }

go3gppCompliance MODULE-COMPLIANCE
  STATUS current
  DESCRIPTION
    "Describes the requirements for conformance to the
    3GPP GO PIB."

  MODULE FRAMEWORK-PIB          -- Defined in RFC 3318 [15]
    MANDATORY-GROUPS {
      frwkPrcSupportGroup,
      frwkDeviceIdGroup,
      frwkBaseFilterGroup,
      frwkIpFilterGroup }

  MODULE GO3GPP-PIB -- this module
    MANDATORY-GROUPS {
      go3gppAuthReqCapGroup,
      go3gppAuthReqDecCapGroup,
      go3gppAuthReqHandlerGroup,
      go3gppAuthReqEventGroup,
      go3gppBindingInfoGroup,
      go3gppFlowIdGroup,
      go3gppAuthReqFailDecGroup,
      go3gppAuthReqDecGroup,
      go3gppIcidGroup,
      go3gppAuthReqDirDecGroup,
      go3gppQosGroup,
      go3gppGateDecGroup,
      go3gppGateGroup,
      go3gppReportGroup,
      go3gppRprtGPRSchrgInfoGroup,
      go3gppRprtUsageGroup }
    ::= { go3gppCompliances 1 }

go3gppAuthReqCapGroup OBJECT-GROUP
  OBJECTS {
    go3gppAuthReqCapBindingInfos,
    go3gppAuthReqCapFlowIds
  }
  STATUS current
  DESCRIPTION
    "This Group defines the PIB Objects that describe the
    Authorization Request capabilities."
  ::= { go3gppGroups 1 }

go3gppAuthReqDecCapGroup OBJECT-GROUP
  OBJECTS {
    go3gppAuthReqDecCapIcids
  }
  STATUS current
  DESCRIPTION
    "This Group defines the PIB
    Objects that describe the Authorization Decision capabilities."
  ::= { go3gppGroups 2 }

go3gppAuthReqHandlerGroup OBJECT-GROUP
  OBJECTS {
    go3gppAuthReqHandlerEnable,
    go3gppAuthReqHandlerBindingInfo
  }
  STATUS current
  DESCRIPTION
    "This Group defines the PIB
    Objects that describe the Authorization request event handler."
  ::= { go3gppGroups 3 }

```



```
go3gppAuthReqEventGroup OBJECT-GROUP
OBJECTS {
  go3gppAuthReqEventBindingInfos
}
STATUS current
DESCRIPTION
  "This Group defines the PIB
  Objects that describe the Authorization request events."
 ::= { go3gppGroups 4 }

go3gppBindingInfoGroup OBJECT-GROUP
OBJECTS {
  go3gppBindingInfoToken,
  go3gppBindingInfoFlowIds,
  go3gppBindingInfoNext
}
STATUS current
DESCRIPTION
  "This Group defines the PIB
  Objects that describe the binding information."
 ::= { go3gppGroups 5 }

go3gppFlowIdGroup OBJECT-GROUP
OBJECTS {
  go3gppFlowIdFlowId,
  go3gppFlowIdNext
}
STATUS current
DESCRIPTION
  "This Group defines the PIB
  Objects that describe the flow identifier."
 ::= { go3gppGroups 6 }

go3gppAuthReqFailDecGroup OBJECT-GROUP
OBJECTS {
  go3gppAuthReqFailDecReason
}
STATUS current
DESCRIPTION
  "This Group defines the PIB
  Objects that describe the Authorization failure decisions."
 ::= { go3gppGroups 7 }

go3gppAuthReqDecGroup OBJECT-GROUP
OBJECTS {
  go3gppAuthReqDecIcids,
  go3gppAuthReqDecDirDecs
}
STATUS current
DESCRIPTION
  "This Group defines the PIB
  Objects that describe the Authorization decisions."
 ::= { go3gppGroups 8 }

go3gppIcidGroup OBJECT-GROUP
OBJECTS {
  go3gppIcidValue,
  go3gppIcidNext
}
STATUS current
DESCRIPTION
  "This Group defines the PIB
  Objects that describe the ICID."
 ::= { go3gppGroups 9 }

go3gppAuthReqDirDecGroup OBJECT-GROUP
OBJECTS {
  go3gppAuthReqDirDecDirection,
  go3gppAuthReqDirDecQos,
  go3gppAuthReqDirDecGates,
  go3gppAuthReqDirDecNext
}
STATUS current
DESCRIPTION
  "This Group defines the PIB
  Objects that describe the authorization decision direction."
 ::= { go3gppGroups 10 }
```

```
go3gppQoSGroup OBJECT-GROUP
  OBJECTS {
    go3gppQoSServiceClass,
    go3gppQoSDataRateUnit,
    go3gppQoSDataRate
  }
  STATUS current
  DESCRIPTION
    "This Group defines the PIB
    Objects that describe the QoS information."
  ::= { go3gppGroups 11 }

go3gppGateDecGroup OBJECT-GROUP
  OBJECTS {
    go3gppGateDecDirection,
    go3gppGateDecGates,
    go3gppGateDecNext
  }
  STATUS current
  DESCRIPTION
    "This Group defines the PIB
    Objects that describe the Gate decision."
  ::= { go3gppGroups 12 }

go3gppGateGroup OBJECT-GROUP
  OBJECTS {
    go3gppGateFilter,
    go3gppGateStatus,
    go3gppGateNext
  }
  STATUS current
  DESCRIPTION
    "This Group defines the PIB
    Objects that describe the gate."
  ::= { go3gppGroups 13 }

go3gppReportGroup OBJECT-GROUP
  OBJECTS {
    go3gppReportStatus,
    go3gppReportDetails
  }
  STATUS current
  DESCRIPTION
    "This Group defines the PIB
    Objects that describe the PEP reports."
  ::= { go3gppGroups 14 }

go3gppRprtGPRSchrgInfoGroup OBJECT-GROUP
  OBJECTS {
    go3gppRprtGPRSchrgInfoAddrType,
    go3gppRprtGPRSchrgInfoGGSNAddr,
    go3gppRprtGPRSchrgInfoGCID
  }
  STATUS current
  DESCRIPTION
    "This Group defines the PIB
    Objects that describe the charging information."
  ::= { go3gppGroups 15 }

go3gppRprtUsageGroup OBJECT-GROUP
  OBJECTS {
    go3gppRprtUsageIndication
  }
  STATUS current
  DESCRIPTION
    "This Group defines the PIB
    Objects that describe the report usage."
  ::= { go3gppGroups 16 }
```

END

Annex C (normative): Flow identifiers: Format definition and examples

C.1 Format of a flow identifier

A flow identifier is expressed as a 2-tuple as follows:

<The ordinal number of the position of the media component description in the SDI , The ordinal number of the IP flow(s) within the media component description assigned in the order of increasing uplink port numbers as detailed below >

where both are numbered starting from 1. The encoding of the flow identifier is as indicated in 3GPP TS 24.008 [12].

If UE and AF share an algorithm for a given application, which guarantees that UE and AF assign the same ordinal number to each media component, the ordinal numbers of the IP Flows within a media component shall be assigned according to the following rules:

- All IP flow(s) or bidirectional combinations of two IP flow(s) within the media component, for which an uplink destination port number is available, shall be assigned ordinal numbers in the order of uplink destination port numbers.
- All IP flows, where no uplink destination port number is available, shall be assigned the next higher ordinal numbers in the order of downlink destination port numbers.

The ordinal number of a media component shall not be changed when the session description information is modified.

For SDP, the flow identifier shall be assigned in the following way:

The ordinal number of the position of the "m=" line in the SDP	The ordinal number of the IP flow(s) within the 'm=' line assigned in the order of increasing uplink destination port numbers, if uplink destination port numbers are available. For downlink or inactive unicast media IP flows, an uplink destination port number is nevertheless available, if SDP offer-answer according to RFC 3264 is used. The ordinal number of the IP flow(s) within the 'm=' line assigned in the order of increasing downlink destination port numbers, if no uplink destination port numbers are available.
--	---

If no SDI with fixed and unique positions for media components is exchanged between UE and AF, the UE and AF may assign the ordinal numbers of the media components in another application-dependent algorithm which guarantees that UE and AF assign the same ordinal number to each media component.

If UE and AF do not share an algorithm for a given application, which guarantees that UE and AF assign the same ordinal number to each media component, the ordinal number of the media component shall be set to zero and the ordinal number of the IP flows shall be assigned according to the following rules:

1. If ordinal numbers for several IP flows are assigned at the same time, all uplink IP flows shall be assigned lower ordinal number than all downlink IP flows.

2. If ordinal numbers for several IP flows are assigned at the same time, all uplink and all downlink IP flows shall separately be assigned ordinal numbers according to increasing internet protocol number assigned by IANA (e.g. 8 for TCP and 17 for UDP)
3. If ordinal numbers for several IP flows are assigned at the same time, for each internet protocol with a port concept, all uplink and all downlink IP flows of this internet protocol shall separately be assigned ordinal numbers according to increasing port numbers.
4. If IP flows are removed from an existing session, the previously assigned binding info shall remain unmodified for the remaining IP flows.
5. If IP flows are added to an existing session, the previously assigned binding info shall remain unmodified and the new IP flows shall be assigned ordinal numbers following the rules 1. to 3., starting with the first previously unused ordinal number. The numbers freed in step 4. shall not be reused.

C.2 Example 1

An UE, as the offerer, sends a SDP session description, as shown in table C.2.1, to an application server (only relevant SDP parameters are shown):

Table C.2.1: The values of the SDP parameters sent by the UE in example 1.

<pre>v=0 o=ecsreid 3262464865 3262464868 IN IP6 2001:0646:00F1:0045:02D0:59FF:FE14:F33A s=MM01 i=One unidirectional audio media and one unidirectional video media and one bidirectional application media t=3262377600 3262809600 m=video 50230 RTP/AVP 31 c=IN IP6 2001:0646:00F1:0045:02D0:59FF:FE14:F33A a=recvonly m=audio 50330 RTP/AVP 0 c=IN IP6 2001:0646:00F1:0045:02D0:59FF:FE14:F33A a=sendonly m=application 50430 udp wb c=IN IP6 2001:0646:00F1:0045:02D0:59FF:FE14:F33A a=sendrecv</pre>
--

and receives the SDP parameters, as shown in table C.2.2, from the application server:

Table C.2.2: The values of the SDP parameters sent by the application server in example 1.

<pre>v=0 o=ecsreid 3262464865 3262464868 IN IP6 2001:0646:00F1:0045:02D0:59FF:FE14:F33A s=MM01 i=One unidirectional audio media and one unidirectional video media and one bidirectional application media t=3262377600 3262809600 m=video 51372 RTP/AVP 31 c=IN IP6 2001:0646:000A:03A7:02D0:59FF:FE40:2014 a=sendonly m=audio 49170 RTP/AVP 0 c=IN IP6 2001:0646:000A:03A7:02D0:59FF:FE40:2014 a=recvonly m=application 32416 udp wb c=IN IP6 2001:0646:000A:03A7:0250:DAFF:FE0E:C6F2 a=sendrecv</pre>
--

From this offer–answer exchange of SDP parameters the UE and the PDF each creates a list of flow identifiers comprising the IP flows as shown in table C.2.3:

Table C.2.3: Flow identifiers in example 1.

Order of "m=" -line	Type of IP flows	Destination IP address / Port number of the IP flows	Flow identifier
1	RTP (Video) DL	2001:0646:00F1:0045:02D0:59FF:FE14:F33A / 50230	<1,1>
1	RTCP DL	2001:0646:00F1:0045:02D0:59FF:FE14:F33A / 50231	<1,2>
1	RTCP UL	2001:0646:000A:03A7:02D0:59FF:FE40:2014 / 51373	<1,2>
2	RTP (Audio) UL	2001:0646:000A:03A7:02D0:59FF:FE40:2014 / 49170	<2,1>
2	RTCP DL	2001:0646:00F1:0045:02D0:59FF:FE14:F33A / 50331	<2,2>
2	RTCP UL	2001:0646:000A:03A7:02D0:59FF:FE40:2014 / 49171	<2,2>
3	UDP (application) DL	2001:0646:00F1:0045:02D0:59FF:FE14:F33A / 50430	<3,1>
3	UDP (application) UL	2001:0646:000A:03A7:0250:DAFF:FE0E:C6F2 / 32416	<3,1>

C.3 Example 2

In the general case, multiple ports may be specified with a "number of ports" qualifier as follows, RFC 2327 [17]:

m=<media> <port>/<number of ports> <transport> <fmt list>

An UE, as the offerer, sends a SDP session description, as shown in table C.3.1, to an application server (only relevant SDP parameters are shown):

Table C.3.1: The values of the SDP parameters sent by the UE in example 2.

```
v=0
o=ecsreid 3262464321 3262464325 IN IP6 2001:0646:00F1:0045:02D0:59FF:FE14:F33A
s=MM02
i=One unidirectional audio media consisting of two media IP flows described by one media component
t=3262377600 3262809600
m=audio 50330/2 RTP/AVP 0
c=IN IP6 2001:0646:00F1:0045:02D0:59FF:FE14:F33A
a=recvonly
```

and receives the SDP parameters, as shown in table C.3.2, from the application server:

Table C.3.2: The values of the SDP parameters sent by the application server in example 2.

```
v=0
o=ecsreid 3262464321 3262464325 IN IP6 2001:0646:00F1:0045:02D0:59FF:FE14:F33A
s=MM02
i=One unidirectional audio media consisting of two media IP flows described by one media component
t=3262377600 3262809600
m=audio 49170/2 RTP/AVP 0
c=IN IP6 2001:0646:000A:03A7:02D0:59FF:FE40:2014
a=sendonly
```

From this offer–answer exchange of SDP parameters the UE and the PDF each creates a list of flow identifiers comprising the IP flows as shown in table C.3.3:

Table C.3.3: Flow identifiers in example 2.

Order of "m="line	Type of IP flows	Destination IP address / Port number of the IP flows	Flow identifier
1	RTP (audio) DL	2001:0646:00F1:0045:02D0:59FF:FE14:F33A / 50330	<1,1>
1	RTCP DL	2001:0646:00F1:0045:02D0:59FF:FE14:F33A / 50231	<1,2>
1	RTCP UL	2001:0646:000A:03A7:02D0:59FF:FE40:2014 / 49171	<1,2>
1	RTP (audio) DL	2001:0646:00F1:0045:02D0:59FF:FE14:F33A / 50332	<1,3>
1	RTCP DL	2001:0646:00F1:0045:02D0:59FF:FE14:F33A / 50333	<1,4>
1	RTCP UL	2001:0646:000A:03A7:02D0:59FF:FE40:2014 / 49173	<1,4>

C.4 Example 3 without media components.

The UE and AF do not exchange SDP for an application and do not share an algorithm, which guarantees that UE and AF assign the same ordinal number to each media component.

At the AF session initiation, the UE and AF agree to set up the following IP flows:

- Uplink UDP flow with destination port 100.
- Downlink UDP flow with destination port 100.
- Downlink TCP flow with destination port 100.
- Uplink TCP flow with destination port 100.
- Uplink UDP flow with destination port 200.

The following binding info is assigned to these IP flows.

- Uplink UDP flow with destination port 100: (0, 2)
- Downlink UDP flow with destination port 100: (0, 5)
- Downlink TCP flow with destination port 100: (0, 4)
- Uplink TCP flow with destination port 100: (0, 1)
- Uplink UDP flow with destination port 200: (0, 3)

At a later stage in the session, the TCP IP flows are removed and the following IP flows are added:

- Uplink UDP flow with destination port 150.
- Downlink UDP flow with destination port 50.

The following binding info is assigned to the IP flows existing at this stage:

- Uplink UDP flow with destination port 100: (0, 2)
- Downlink UDP flow with destination port 100: (0, 5)
- Uplink UDP flow with destination port 200: (0, 3)
- Uplink UDP flow with destination port 150: (0, 6)
- Downlink UDP flow with destination port 50: (0, 7)

C.5 Example 4

In this example, the SDP 'a=rtcp' attribute defined in IETF RFC 3605 is used.

An UE, as the offerer, sends a SDP session description, as shown in table C.5.1, to an application server (only relevant SDP parameters are shown):

Table C.5.1: The values of the SDP parameters sent by the UE in example 1.

```
v=0
o=ecsreid 3262464865 3262464868 IN IP6 2001:0646:00F1:0045:02D0:59FF:FE14:F33A
s=MM01
i=One unidirectional video media
t=3262377600 3262809600
m=video 50230 RTP/AVP 31
c=IN IP6 2001:0646:00F1:0045:02D0:59FF:FE14:F33A
```

```
a=recvonly
a=rtcp:53020
```

and receives the SDP parameters, as shown in table C.5.2, from the application server:

Table C.5.2: The values of the SDP parameters sent by the application server in example 1.

```
v=0
o=ecsreid 3262464865 3262464868 IN IP6 2001:0646:00F1:0045:02D0:59FF:FE14:F33A
s=MM01
i=One unidirectional video media
t=3262377600 3262809600
m=video 51372 RTP/AVP 31
c=IN IP6 2001:0646:000A:03A7:02D0:59FF:FE40:2014
a=sendonly
a=rtcp:49320
```

From this offer–answer exchange of SDP parameters the UE and the PDF each creates a list of flow identifiers comprising the IP flows as shown in table C.5.3:

Table C.5.3: Flow identifiers in example 4.

Order of "m=" -line	Type of IP flows	Destination IP address / Port number of the IP flows	Flow identifier
1	RTP (Video) DL	2001:0646:00F1:0045:02D0:59FF:FE14:F33A / 50230	<1,2>
1	RTCP DL	2001:0646:00F1:0045:02D0:59FF:FE14:F33A / 53020	<1,1>
1	RTCP UL	2001:0646:000A:03A7:02D0:59FF:FE40:2014 / 49320	<1,1>

Annex D (normative): Go interface related error code values for the PDP context handling

The following error codes are used to indicate Go interface related errors from the GGSN to the UE. The error codes listed below are transferred to the UE in the Protocol Configuration Options information element as defined in 3GPP TS 24.008 [12]:

The error code values transported in the container contents field shall be the binary representations of the error code numbers listed below.

In all the cases listed below a common GTP cause code, "User authentication failed", see 3GPP TS 29 060 [20], shall be used in the response message.

Error code No. 1 "Authorization failure of the request"

This error code indicates that the secondary PDP context request is rejected because the authorizing entity is unable to provide an authorization decision for the binding information.

Error code No. 2 "Missing binding information"

This error code indicates that the secondary PDP context activation or PDP context modification request is rejected because the binding information was not included in the request although required.

Error code No. 3 "Invalid binding information"

This error code indicates that the secondary PDP context activation or PDP context modification request is rejected because the authorizing entity could not be resolved from the binding information.

Error code No. 4 "Binding information not allowed"

This error code indicates that the secondary PDP context activation or PDP context modification request is rejected because the Go interface is disabled or not supported in the GGSN and hence binding information is not allowed. The error code may also indicate that the PDP context modification is rejected because binding information is not allowed for modification of previously non-authorized PDP context or that the binding information is not allowed when the PDP context is indicated to be used for IMS signaling.

Error code No.5 "Authorizing entity temporarily unavailable"

This error code indicates that the secondary PDP context activation or PDP context modification request is rejected because the authorizing entity indicated by the binding information is temporarily unavailable.

Error code No. 6 "No corresponding session"

This error code indicates that the secondary PDP context activation request is rejected because the authorizing entity cannot associate the Authorisation token of binding information with any ongoing session or binding information contains invalid flow identifier(s). The error code also indicates that the PDP context modification request is rejected by the authorizing entity because the authorization token has changed or the binding information contains invalid flow identifier(s).

Error code No. 7 "Invalid bundling"

This error code indicates that the secondary PDP context activation or PDP context modification request is rejected because the authorizing entity does not allow the grouping of the flow identifiers in the same PDP Context.

Annex E (informative): Overview of the 3GPP Go PIB working mode

When the GGSN initialise for the first time, the PEP instances are initialised. The GGSN will use a TCP connection with the PDF (that will be created as specified in the normative text above subclause 6.1.1) in order to transport COPS protocol.

Then, the GGSN sends the first COPS REQ message to the PDF indicating capabilities and the supported PRCs. This is done using:

frwkSupportTable containing the supported PRCs and attributes.

frwkDeviceIdTable used to facilitate efficient policy communication by a PDP. The PDP can take into account certain device characteristics during policy installation as hardware and software of the GGSN, or maximum COPS-PR message size.

go3gppAuthReqCapTable indicating the maximum number of Binding Information and maximum number of Flow Identifiers the PEP can send with each Authorization Request.

go3gppAuthReqDecCapTable indicating the maximum number of ICID possible in a single Authorization Request Decision.

Then, the PDF send to the PEP PRCs for indicating how to handle each kind of event that require actions by the Go interface. This is done in a COPS DEC message using:

go3gppAuthReqHandlerTable indicating Go actions to take at the GGSN when an Authorization Request Event is detected by the GGSN (an example of an Authorization Request Event is the receive of a PDP Context message); the maximum number of Binding Information associated with each Authorization Request; and if COPS Req. can be triggered, are also indicated here.

Then, the GGSN will send PRCs to the PDF in a COPS REQ indicating the detection of specific events in the GGSN (i.e. when the GGSN receives the PDP context activation). Information required to PDF on behave of GGSN is carried also by REQ messages. This is done using:

go3gppAuthReqEventTable indicates Authorization Request Event and its relevant information (binding information **go3gppBindingInfoTable**, **go3gppFlowIDTable**).

Then, PRCs carrying the Event Decision sent from PDF to PEP are carried by the COPS DEC message. These PRCs include support for Gates/Filters, QoS, ICIDs.

If the authorization request is rejected (for reasons such as no corresponding session was found by the PDF, incorrect bundling and others) a COPS-PR DEC containing the reason (**go3gppAuthReqFailDecTable**) is sent.

If not, the following PRCs are sent:

go3gppAuthReqDecTable indicates an ICID for each binding information received. To do so, table **go3gppIcidTable** is used. Also for each binding information a Directional Decision is sent (**go3gppAuthreqDirDecTable**)

Within the later the following is indicated:

- The direction where the decision applies (uplink or downlink).
- The Auth QoS (**go3gppQoSTable**) indicating the service class through DSCP encoding, and the data rate to be applied in the PDP requesting authorization.
- The gate definition (**go3gppGateTable**): including status (open/closed), and Ip filter definition through the **frwkBaseFilterTable** and **frwkIpFilterTable** (which includes source and destination address, port, protocol, etc).

There is, also, the possibility of sending, in a different COPS DEC message from the one carrying the **go3gppAuthReqDec**, information about changing status of the Gate. This is done using the **go3gppGateDecTable**, that includes the direction to which this decision applies and a reference to a **go3gppGateTable**.

Finally, the PEP will send to the PDF PRCs with the information on the Decision enforcement result. This is done in the COPS REPORT message. These PRCs include support for the success or failure of the PEP in carrying out the PDF's decision or change of the state in the GGSN, and are:

go3gppReportTable will indicate the status of the enforcement: success or failure or usage.

- If success, then, the **go3gppRprtGPRSChrgInfoTable** is sent to indicate the details for charging (GGSN address and GCID).
- If failure, then, the standard COPS-PR error handling mechanism and error objects are enough.
- Usage means that GPRS Usage has changed to 0kbps or from 0kbps. **go3gppUsageTable** is used.

To be conformant to the Go PIB, on top of the Go PIB PRCs defined in the present document, is mandatory to include from the framework PIB: frwkPrcSupportGroup, frwkDeviceGroup.

The PDF can revoke the authorization by using the Remove_Decision at any time the current specification indicates that this action is required. The GGSN sends a COPS DRQ message to ultimately remove the corresponding state in the PDF.

The Handle included in the COPS message will be used as the unique number to correlate all the COPS messages with the same dialogue.

Annex F (informative): Change history

Change history							
Date	TSG #	TSG Doc.	CR	Rev	Subject/Comment	Old	New
2004-06	NP#24	NP-040247	129		Multiple IMS sessions using the same PDP context	5.8.0	6.0.0
2004-09	NP#25	NP-040333	132	2	COPS DEC message handling	6.0.0	6.1.0
2004-09	NP#25	NP-040333	134	2	COPS-PR 'Request State' flag not set for authorization failure decision	6.0.0	6.1.0
2004-09	NP#25	NP-040338	137		Accumulated CR on Gq impacts	6.0.0	6.1.0
2004-12	NP#26	NP-040560	138	2	SBLP and non-real-time PDP Contexts	6.1.0	6.2.0
2004-12	NP#26	NP-040560	142	3	QoS procedure at session release	6.1.0	6.2.0
2005-03	NP#27	NP-050106	150	3	Clarification on charging identifier(s) exchange	6.2.0	6.3.0

History

Document history		
V6.2.0	December 2004	Publication
V6.3.0	March 2005	Publication