

ETSI TS 129 232 V6.9.0 (2007-03)

Technical Specification

**Universal Mobile Telecommunications System (UMTS);
Media Gateway Controller (MGC) -
Media Gateway (MGW) interface;
Stage 3
(3GPP TS 29.232 version 6.9.0 Release 6)**



Reference

RTS/TSGC-0429232v690

Keywords

UMTS

ETSI

650 Route des Lucioles
F-06921 Sophia Antipolis Cedex - FRANCE

Tel.: +33 4 92 94 42 00 Fax: +33 4 93 65 47 16

Siret N° 348 623 562 00017 - NAF 742 C
Association à but non lucratif enregistrée à la
Sous-Préfecture de Grasse (06) N° 7803/88

Important notice

Individual copies of the present document can be downloaded from:

<http://www.etsi.org>

The present document may be made available in more than one electronic version or in print. In any case of existing or perceived difference in contents between such versions, the reference version is the Portable Document Format (PDF). In case of dispute, the reference shall be the printing on ETSI printers of the PDF version kept on a specific network drive within ETSI Secretariat.

Users of the present document should be aware that the document may be subject to revision or change of status. Information on the current status of this and other ETSI documents is available at

<http://portal.etsi.org/tb/status/status.asp>

If you find errors in the present document, please send your comment to one of the following services:

http://portal.etsi.org/chaicor/ETSI_support.asp

Copyright Notification

No part may be reproduced except as authorized by written permission.
The copyright and the foregoing restriction extend to reproduction in all media.

© European Telecommunications Standards Institute 2007.
All rights reserved.

DECTTM, **PLUGTESTS**TM and **UMTS**TM are Trade Marks of ETSI registered for the benefit of its Members.
TIPHONTM and the **TIPHON logo** are Trade Marks currently being registered by ETSI for the benefit of its Members.
3GPPTM is a Trade Mark of ETSI registered for the benefit of its Members and of the 3GPP Organizational Partners.

Intellectual Property Rights

IPRs essential or potentially essential to the present document may have been declared to ETSI. The information pertaining to these essential IPRs, if any, is publicly available for **ETSI members and non-members**, and can be found in ETSI SR 000 314: *"Intellectual Property Rights (IPRs); Essential, or potentially Essential, IPRs notified to ETSI in respect of ETSI standards"*, which is available from the ETSI Secretariat. Latest updates are available on the ETSI Web server (<http://webapp.etsi.org/IPR/home.asp>).

Pursuant to the ETSI IPR Policy, no investigation, including IPR searches, has been carried out by ETSI. No guarantee can be given as to the existence of other IPRs not referenced in ETSI SR 000 314 (or the updates on the ETSI Web server) which are, or may be, or may become, essential to the present document.

Foreword

This Technical Specification (TS) has been produced by ETSI 3rd Generation Partnership Project (3GPP).

The present document may refer to technical specifications or reports using their 3GPP identities, UMTS identities or GSM identities. These should be interpreted as being references to the corresponding ETSI deliverables.

The cross reference between GSM, UMTS, 3GPP and ETSI identities can be found under <http://webapp.etsi.org/key/queryform.asp>.

Contents

| | |
|--|----|
| Intellectual Property Rights | 2 |
| Foreword..... | 2 |
| Foreword..... | 7 |
| 1 Scope | 8 |
| 2 References | 8 |
| 3 Definitions, symbols and abbreviations | 9 |
| 3.1 Definitions | 9 |
| 3.2 Symbols..... | 10 |
| 3.3 Abbreviations | 10 |
| 4 UMTS capability set..... | 10 |
| 4.1 Profile Identification..... | 10 |
| 4.2 Profile Registration..... | 11 |
| 5 Naming conventions..... | 11 |
| 5.1 MGC/MGW naming conventions | 11 |
| 5.2 Termination names | 11 |
| 5.2.1 Termination naming convention | 11 |
| 5.2.2 Termination naming convention for TDM terminations..... | 12 |
| 6 Topology descriptor | 13 |
| 7 Transaction timers | 13 |
| 8 Transport | 13 |
| 9 Multiple Virtual MG. | 13 |
| 10 Formats and codes | 13 |
| 11 Mandatory Support of SDP and H.248.1 annex C information elements | 15 |
| 12 General on Packages and Transactions | 15 |
| 13 BICC packages | 17 |
| 13.1 Mandatory BICC packages..... | 17 |
| 13.2 Optional BICC packages | 17 |
| 14 H.248 standard packages | 17 |
| 14.1 Call independent H.248 transactions | 18 |
| 14.1.1 MGW Out of service/Maintenance Locking..... | 18 |
| 14.1.2 MGW Communication Up..... | 19 |
| 14.1.3 MGW Restoration..... | 19 |
| 14.1.4 MGW Register..... | 19 |
| 14.1.5 MGW Re-register | 20 |
| 14.1.6 (G)MSC Server Ordered Re-register | 20 |
| 14.1.7 (G)MSC Server Restoration..... | 20 |
| 14.1.8 Termination Out-of-Service..... | 20 |
| 14.1.9 Termination Restoration | 21 |
| 14.1.10 Audit Value..... | 21 |
| 14.1.11 Audit Capability..... | 23 |
| 14.1.12 MGW Capability Change | 24 |
| 14.1.13 (G)MSC Server Out of Service..... | 24 |
| 14.1.14 MGW Resource Congestion Handling - Activate..... | 24 |
| 14.1.15 MGW Resource Congestion Handling - Indication | 24 |
| 14.1.16 Continuity Check Tone | 25 |
| 14.1.17 Continuity Check Verify..... | 25 |
| 14.1.18 Continuity Check Response..... | 25 |

| | | |
|----------|--|----|
| 14.2 | Call related H.248 transactions..... | 25 |
| 14.2.1 | Change Flow Direction..... | 27 |
| 14.2.2 | Isolate Bearer Termination..... | 27 |
| 14.2.3 | Join Bearer Termination..... | 27 |
| 14.2.4 | Establish Bearer..... | 27 |
| 14.2.5 | Prepare Bearer..... | 28 |
| 14.2.6 | Change Through Connection..... | 28 |
| 14.2.7 | Activate Interworking Function..... | 28 |
| 14.2.8 | Release procedures..... | 29 |
| 14.2.8.1 | Release Bearer..... | 29 |
| 14.2.8.2 | Release Termination..... | 29 |
| 14.2.9 | Bearer Released..... | 30 |
| 14.2.10 | Bearer Established..... | 30 |
| 14.2.11 | Send Tone..... | 30 |
| 14.2.12 | Play Announcement..... | 30 |
| 14.2.13 | Send DTMF..... | 30 |
| 14.2.14 | Detect DTMF..... | 30 |
| 14.2.15 | Report DTMF..... | 31 |
| 14.2.16 | Announcement Completed..... | 31 |
| 14.2.17 | Activate Voice Processing Function..... | 31 |
| 14.2.18 | Reserve Circuit..... | 31 |
| 14.2.19 | Tunnel Information Up..... | 32 |
| 14.2.20 | Tunnel Information Down..... | 32 |
| 14.2.21 | Tone Completed..... | 33 |
| 14.2.22 | Stop Announcement..... | 33 |
| 14.2.23 | Stop Tone..... | 33 |
| 14.2.24 | Stop DTMF Detection..... | 33 |
| 14.2.25 | Stop DTMF..... | 33 |
| 14.2.26 | Confirm Char..... | 33 |
| 14.2.27 | Modify Char..... | 33 |
| 14.2.28 | Reserve Char..... | 33 |
| 14.2.29 | Bearer Modified..... | 33 |
| 14.2.30 | Bearer Modification Failed..... | 33 |
| 14.2.31 | TFO Activation..... | 33 |
| 14.2.32 | Optimal Codec and Distant List_Notify..... | 34 |
| 14.2.33 | Codec Modify..... | 34 |
| 14.2.34 | Distant Codec List..... | 35 |
| 14.2.35 | Command Rejected..... | 35 |
| 14.2.36 | Modify Bearer Characteristics..... | 36 |
| 14.2.37 | Protocol Negotiation Result..... | 36 |
| 14.2.38 | Rate Change..... | 37 |
| 14.2.39 | Bearer Modification Support..... | 37 |
| 14.2.40 | CTM report..... | 37 |
| 14.2.41 | Prepare IP transport..... | 38 |
| 14.2.42 | Modify IP transport address..... | 39 |
| 14.2.43 | Reserve Bearer Characteristics..... | 40 |
| 14.2.44 | Confirm Bearer Characteristics..... | 40 |
| 14.2.45 | Trace activation/deactivation..... | 40 |
| 14.2.46 | Trace Activation result notification..... | 41 |
| 14.2.47 | Emergency Call Indication..... | 42 |
| 14.2.48 | TFO status Notify..... | 42 |
| 14.2.49 | TFO Status..... | 43 |
| 15 | UMTS packages..... | 43 |
| 15.1 | Mandatory UMTS packages..... | 43 |
| 15.1.1 | 3GUP package..... | 44 |
| 15.1.1.1 | Properties..... | 44 |
| 15.1.1.2 | Events..... | 46 |
| 15.1.1.3 | Signals..... | 46 |
| 15.1.1.4 | Statistics..... | 46 |
| 15.1.1.5 | Procedures..... | 46 |
| 15.1.2 | Void..... | 49 |

| | | |
|----------|--|----|
| 15.1.3 | Void | 49 |
| 15.1.4 | Void | 49 |
| 15.1.5 | Void | 49 |
| 15.1.6 | Void | 49 |
| 15.1.7 | Void | 49 |
| 15.1.8 | Void | 49 |
| 15.1.9 | Void | 49 |
| 15.2 | Optional UMTS packages | 49 |
| 15.2.1 | Circuit Switched Data package | 49 |
| 15.2.1.1 | Properties | 49 |
| 15.2.1.2 | Events | 50 |
| 15.2.1.3 | Signals | 51 |
| 15.2.1.4 | Statistics | 51 |
| 15.2.1.5 | Procedures | 51 |
| 15.2.2 | TFO package | 52 |
| 15.2.2.1 | Properties | 52 |
| 15.2.2.2 | Events | 53 |
| 15.2.2.3 | Signals | 55 |
| 15.2.2.4 | Statistics | 55 |
| 15.2.2.5 | Procedures | 55 |
| 15.2.3 | 3G Expanded Call Progress Tones Generator Package | 55 |
| 15.2.3.1 | Properties | 55 |
| 15.2.3.2 | Events | 55 |
| 15.2.3.3 | Signals | 55 |
| 15.2.3.4 | Statistics | 56 |
| 15.2.3.5 | Procedures | 56 |
| 15.2.4 | Modification Of Link Characteristics Bearer Capability | 56 |
| 15.2.4.1 | Properties | 56 |
| 15.2.4.2 | Events | 56 |
| 15.2.4.3 | Signals | 56 |
| 15.2.4.4 | Statistics | 57 |
| 15.2.4.5 | Procedures | 57 |
| 15.2.5 | Enhanced Circuit Switched Data package | 57 |
| 15.2.5.1 | Properties | 57 |
| 15.2.5.2 | Events | 57 |
| 15.2.5.3 | Signals | 57 |
| 15.2.5.4 | Statistics | 57 |
| 15.2.5.5 | Procedures | 57 |
| 15.2.6 | Cellular Text telephone Modem Text Transport | 57 |
| 15.2.6.1 | Properties | 58 |
| 15.2.6.2 | Events | 59 |
| 15.2.6.3 | Signals | 59 |
| 15.2.6.4 | Statistics | 59 |
| 15.2.6.5 | Procedures | 59 |
| 15.2.7 | IP transport package | 60 |
| 15.2.7.1 | Properties | 60 |
| 15.2.7.2 | Events | 60 |
| 15.2.7.3 | Signals | 61 |
| 15.2.7.4 | Statistics | 61 |
| 15.2.7.5 | Procedures | 61 |
| 15.2.8 | Flexible Tone Generator Package | 61 |
| 15.2.8.1 | Properties | 61 |
| 15.2.8.2 | Events | 61 |
| 15.2.8.3 | Signals | 61 |
| 15.2.8.4 | Statistics | 63 |
| 15.2.8.5 | Procedures | 63 |
| 15.2.9 | Trace Package | 63 |
| 15.2.9.1 | Properties | 63 |
| 15.2.9.2 | Events | 65 |
| 15.2.9.3 | Signals | 65 |
| 15.2.9.4 | Statistics | 65 |
| 15.2.9.5 | Procedures | 65 |

Annex A (informative): The Framing protocol Interworking Function (FPIF)67

A.1 Introduction67

A.2 FPIF procedures with respect to Iu framing protocol.....67

A.2.1 Payload68

A.2.2 RFCIs68

A.2.3 FQC.....68

A.2.4 Frame number68

A.3 Relay of status information68

A.3.1 Void.....68

A.3.2 Rate Control Frames.....68

A.3.2 Time Alignment69

Annex B (informative): Examples for Usage of the 3GUP Package "Initialization Direction" Property70

Annex C (informative): Change history71

History75

Foreword

This Technical Specification has been produced by the 3rd Generation Partnership Project (3GPP).

The contents of the present document are subject to continuing work within the TSG and may change following formal TSG approval. Should the TSG modify the contents of the present document, it will be re-released by the TSG with an identifying change of release date and an increase in version number as follows:

Version x.y.z

where:

- x the first digit:
 - 1 presented to TSG for information;
 - 2 presented to TSG for approval;
 - 3 or greater indicates TSG approved document under change control.
- y the second digit is incremented for all changes of substance, i.e. technical enhancements, corrections, updates, etc.
- z the third digit is incremented when editorial only changes have been incorporated in the document.

1 Scope

The present document describes the protocol to be used on the Media Gateway Controller (MGC) – Media Gateway (MGW) interface. The Media Gateway Controllers covered in this specification are the MSC server and the GMSC server. The basis for this interface profile is the H.248.1 [10] protocol as specified in ITU-T. The BICC architecture as described in 3GPP TS 23.205 [2] and 3GPP TS 29.205 [7] defines the usage of this protocol.

This specification describes the changes to H.248 which are needed to handle 3GPP specific traffic cases. This is done by using the H.248 standard extension mechanism. In addition certain aspects of the base protocol H.248 are not needed for this interface and thus excluded by this profile.

2 References

The following documents contain provisions which, through reference in this text, constitute provisions of the present document.

- References are either specific (identified by date of publication, edition number, version number, etc.) or non-specific.
- For a specific reference, subsequent revisions do not apply.
- For a non-specific reference, the latest version applies. In the case of a reference to a 3GPP document (including a GSM document), a non-specific reference implicitly refers to the latest version of that document *in the same Release as the present document*.

- [1] 3GPP TS 23.153: "Out of band transcoder control; Stage 2".
- [2] 3GPP TS 23.205: "Bearer independent circuit-switched core network; Stage 2".
- [3] 3GPP TS 24.008: "Mobile radio interface Layer 3 specification; Core network protocols; Stage 3".
- [4] 3GPP TS 25.415: "UTRAN Iu interface user plane protocols".
- [5] 3GPP TS 28.062: "Inband Tandem Free Operation (TFO) of speech codecs; Service description; Stage 3".
- [6] 3GPP TS 29.007: "General requirements on interworking between the Public Land Mobile Network (PLMN) and the Integrated Services Digital Network (ISDN) or Public Switched Telephone Network (PSTN)".
- [7] 3GPP TS 29.205: "Application of Q.1900 series to Bearer Independent circuit-switched network architecture; Stage 3".
- [8] 3GPP TS 29.415: "Core Network Nb interface user plane protocols".
- [9] 3GPP TS 48.008: "Mobile Switching Centre - Base Station System (MSC - BSS) interface; Layer 3 specification".
- [10] ITU-T Recommendation H.248.1 (05/2002): "Gateway control protocol". Version 2, including the Corrigendum1 for Version 2 (03/04).
- [11] ITU-T Recommendation Q.2210 (1996): "Message transfer part level 3 functions and messages using the services of ITU-T Recommendation Q.2140".
- [12] IETF RFC 2960: "Stream control transmission protocol".
- [13] 3GPP TS 29.202: "Signalling System No. 7 (SS7) signalling transport in core network; Stage 3".
- [14] ITU-U Recommendation H.248.8: "Error codes and service change reason description".
- [15] ITU-U Recommendation H.248.10: "Media gateway resource congestion handling package".

- [16] 3GPP TS 26.103: "Speech codec list for GSM and UMTS".
- [17] ITU-U Recommendation H.248.2 (01/2005): "Facsimile, text conversation and call discrimination packages".
- [18] 3GPP TS 26.226: "Cellular text telephony; Transport of text in the voice channel".
- [19] ITU-T Recommendation T.140: "Protocol for multimedia application text conversation".
- [20] 3GPP TS 25.413: "UTRAN Iu interface RANAP signalling".
- [21] 3GPP TS 25.414: "UTRAN Iu interface data transport and transport signalling".
- [22] 3GPP TS 23.078: "Customized Applications for Mobile network Enhanced Logic (CAMEL); Stage 2".
- [23] ITU-T Recommendation Q.1950 (12/2002):: "Bearer independent call bearer control protocol".
- [24] ITU-T Recommendation Q.765.5: "Signalling system No. 7 - Application transport mechanism: Bearer Independent Call Control (BICC)".
- [25] ITU-T Recommendation G.711: "Pulse code modulation (PCM) of voice frequencies".
- [26] 3GPP TS 26.102: "3rd Generation Partnership Project; Mandatory speech codec; AMR speech codec; Interface to Iu, Uu and Nb"
- [27] 3GPP TS 23.014: "Technical Specification Group Core Network; Support of Dual Tone Multi-Frequency (DTMF) signalling".
- [28] ITU-T Recommendation H.248.7: "Generic Announcement Package".
- [29] 3GPP TS 32.421: " Subscriber and equipment trace: Trace concepts and requirements "
- [30] 3GPP TS 32.422: "Subscriber and equipment trace: Trace control and configuration management".
- [31] 3GPP TS 32.423: "Subscriber and equipment trace: Trace data definition and management".
- [32] 3GPP TS 29.414: "Core Network Nb data transport and transport signalling".
- [33] ITU-T Recommendation X.213 (11/95): "Information technology - Open systems interconnection - Network Service Definitions".
- [34] IETF RFC 2327: " Session Description Protocol".
- [35] 3GPP TS 43.045: "Technical Realization Of Facsimile Group 3 service - Transparent".
- [36] 3GPP TS 23.172 : "Technical Specification Group Core Network and Terminals;Technical realization of Circuit Switched (CS);multimedia service UDI/RDI fallback and service modification;Stage 2
- [37] 3GPP TS 33.210 : "Technical Specification Group Services and System Aspects;3G Security; Network Domain Security; IP Network Layer Security.
- [38] ITU-T Recommendation X.690: "ASN.1 encoding rules: Specification of Basic Encoding Rules (BER), Canonical Encoding Rules (CER) and Distinguished Encoding Rules (DER)"

3 Definitions, symbols and abbreviations

3.1 Definitions

For the purposes of the present document, the following terms and definitions apply:

context (H.248): association between a number of Terminations

The context describes the topology (who hears/sees whom) and the media mixing and/or switching parameters if more than two terminations are involved in the association.

package (H.248): different types of gateways may implement terminations which have differing characteristics

Variations in terminations are accommodated in the protocol by allowing terminations to have optional properties. Such options are grouped into packages, and a termination may realise a set of such packages.

termination (H.248): logical entity on an MGW which is the source and/or sink of media and/or control streams

A termination is described by a number of characterising properties, which are grouped in a set of descriptors which are included in commands. Each termination has a unique identity (TerminationID).

termination property (H.248): used to describe terminations

Related properties are grouped into descriptors. Each termination property has a unique identity (PropertyID).

3.2 Symbols

For the purposes of the present document, the following symbols apply:

| | |
|----|---|
| Iu | Interface between the RNS and the core network. It is also considered as a reference point. |
| Mc | Interface between the server and the media gateway. |

3.3 Abbreviations

For the purposes of the present document, the following abbreviations apply:

| | |
|------|--|
| BICC | Bearer Independent Call Control |
| M3UA | SS7 MTP3 – User Adaptation Layer |
| MGC | Media Gateway Controller |
| MTP3 | Message Transfer Part layer 3 |
| RFC | Request For Comment; this includes both discussion documents and specifications in the IETF domain |
| SCTP | Stream Control Transmission Protocol |
| TFO | Tandem Free Operation |
| TrFO | Transcoder Free Operation |

4 UMTS capability set

The support of the Mc interface capability set shall be identified by the Mc profile and support of this profile shall then be indicated in ServiceChange procedure via the ServiceChangeProfile parameter as defined in H.248.1 [10] and clarified in section 4.2. The mandatory parts of this profile shall be used in their entirety.. Failure to do so will result in a non-standard implementation.

ITU-T Recommendation H.248.1 [10] shall be the basis for this profile. The compatibility rules for packages, signals, events, properties and statistics and the H.248 protocol are defined in ITU-T Recommendation H.248.1 [10] Their use or exclusion for this interface is clarified in clause 12.

4.1 Profile Identification

Table 4.1.1: Profile Identification

| | |
|---------------|-------------|
| Profile name: | threegbicsn |
| Version: | 2 |

H,248 Protocol version handling shall be implemented. Support of this release of the specification requires support of H.248.1 Version 2. Negotiation of the protocol version shall be in accordance to clause 11.3 of H.248.1 version 2 [10].

4.2 Profile Registration

The following description is based on H.248.1 profile registration procedure with some clarifications. The reply to the ServiceChange Request containing the SCP parameter indicates if the MSC Server supports the requested profile or if it does not support it and wants to propose an alternative profile. The profile (name and version) is only returned in the reply if the MGC cannot support the specified profile in the ServiceChangeRequest. The returned reply shall indicate the profile and version supported or "NoProfile" if no profile is supported. Upon reception of a profile in the reply, if the MGW supports the indicated profile, it shall issue a new ServiceChange Request with the agreed profile to explicitly confirm the acceptance of the profile to the MGC ; otherwise, if the MGW does not support the indicated profile, it may continue the registration or re-registration procedure by issuing a new ServiceChange Request with an alternative profile; until such procedure is successfully completed the MGW shall remain out of service. In the instance that the MGW did not indicate a profile in the original ServiceChangeRequest and the MGC returned a profile in the reply, the MGW shall issue a new ServiceChangeRequest with the appropriate profile or "NoProfile" if no profile is supported. If the profile is not returned the MGC shall use the capabilities specified by the Profile indicated in the service change request.

NOTE: It should be observed that the profile registration is not a "cold calling" negotiation; the operator shall have configured the network to support certain profiles and so the profile registration within the Mc interface permits network upgrade scenarios but otherwise is simply a means to confirm the connection of the profile to be used over the Mc interface between MGC and MGW.

5 Naming conventions

5.1 MGC/MGW naming conventions

The MGC shall be named according to the naming structure of the underlying transport protocol which carries the H.248 protocol.

5.2 Termination names

The Termination ID structure shall follow the guidelines of H.248 and the structure is either relevant or irrelevant for MGC and MGW.

The relevance depends on the utilized bearer type for termination. With ephemeral ATM/AAL2 and IP endpoint bearer types the internal structure of Termination ID is irrelevant for MGW and MGC and therefore Termination ID is only numeric identifier for termination. When bearer type is physical timeslot within TDM circuit the Termination ID structure shall follow the Termination naming convention for TDM circuit bearer.

5.2.1 Termination naming convention

The following general structure of termination ID shall be used:

ASN.1 coding:

4 octets shall be used for the termination ID. The following defines the general structure for the termination ID:

Table 5.2.1: ASN.1 coding

| | |
|------------------|---|
| Termination type | X |
|------------------|---|

Termination type:

Length 3 bits

Values:

000 Reserved

001 Ephemeral termination

010 TDM termination

011 - 110 Reserved

111 Reserved for ROOT termination Id (ROOT Termination ID = 0xFFFFFFFF)

X:

Length 29 bits.

Usage dependent on Termination type. TDM terminations specified below in subclause 5.2.2. Other usage unspecified.

ABNF coding:

TerminationID = "ROOT" / pathName / "\$" / "*" ; According to H.248.1 annex B

With ephemeral termination:

pathName = EphTokenUNDERSCORE(EPHsystem/"*")

EphToken = "Ephemeral"

UNDERSCORE = %x5F ; "_"

EPHsystem : Usage is not specified

5.2.2 Termination naming convention for TDM terminations

ASN.1 coding:

5.2.2: ASN.1 coding

| Termination type (=010) | PCM system | Individual |
|-------------------------|------------|------------|
|-------------------------|------------|------------|

PCM system:

Length 24 bits

Usage unspecified. Uniquely identifies PCM interface in MGw

Individual:

Length: 5 bits

Max. of 32 individuals (timeslots) per PCM system (max. 24 for a 24 channel system)

ABNF coding:

pathName = TDMDToken UNDERSCORE ((PCMsystem / "*") SLASH (Individual / "*"))

TDMDToken = "TDM"

UNDERSCORE = %x5F ; "_"

PCMsystem : Usage not specified

Individual = 1 * 2 (DIGIT) ; 0-31

6 Topology descriptor

The Topology Descriptor shall be supported by the MGW and MGC for handover and lawful interception. It can also be used for sending tones and playing announcements.

7 Transaction timers

All transaction timers specified in ITU-T Recommendation H.248.1 [10] shall be supported in this subset of the protocol.

8 Transport

Each implementation of the Mc interface should provide the appropriate protocol options: MTP3B as defined in ITU-T Recommendation Q.2210 [11] (for ATM signalling transport) or SCTP as defined in RFC 2960 [12] (for IP signalling transport) and in the case where the signalling relation consists of both ATM signalling transport and IP signalling transport the M3UA protocol layer (3GPP TS 29.202 [13]) shall be added to SCTP to provide interworking. M3UA layer may also be added to SCTP for pure IP signalling transport. IPsec shall not be used by MSC Server or MGW for the Mc interface. Normally the Mc interface lies within a single operator's secure domain. If this is not the case then a Za interface (Security Gateway deploying IPsec) may be required, however this is a separate logical function/entity and thus is not attributed to Mc profile, the MSC Server or the MGW; for further details see 3GPP TS 33.210 [37] In summary:

- 1) For pure IP connections, H.248/SCTP/IP should be used. .In addition, to allow for flexible implementations of gateways and controllers in order to offer efficient use of SCTP associations the M3UA layer may also be added on top of SCTP
- 2) For pure ATM connections, H.248/MTP3b/SSCF/SSCOP/AAL5/ATM should be used.
- 3) For mixed IP&ATM connections, H.248/M3UA/SCTP/IP shall be used as the IP transport.

If using SCTP as defined in IETF RFC 2960 [12] the MGW shall always be the node to perform the "Initiation".

For a BICC network with IP transport and IPBCP is transported within H.248 messages, text encoding is not recommended to be used on Mc interface until ITU has resolved the contradiction in RFC2327 [34] and H.248.1 [10] on the usage of CR (ASCII carriage return 0x0d) and/or LF (ASCII newline 0x0a) characters e.g. in SDP these Characters are missing when using the currently specified "quotedString" type.

9 Multiple Virtual MG.

If an MGW is connected to more than one (G)MSC, the MGW shall fulfil the requirements outlined in the subclause "Multiple virtual MGW" in ITU-T Recommendation H.248.1 [10].

10 Formats and codes

Table 1 shows the parameters which are required, in addition to those defined in the subclause "Formats and Codes" of ITU-T Recommendation Q.1950 [23] (see 3GPP TS 29.205 [7]).

The coding rules applied in ITU-T Recommendation H.248.1 [10] for the applicable coding technique shall be followed for the UMTS capability set. . The binary encoding rules which are applicable to the defined Abstract Syntaxes are the Basic Encoding Rules for Abstract Syntax Notation One, defined in ITU-T Recommendation X.690 [38]. Specifically in accordance with ITU-T Recommendation X.690 [38] section 7.3, alternative encodings based on the definite and indefinite form of length are permitted by the basic encoding rules as a sender's option. Receivers shall support both alternatives.

Unsupported values of parameters or properties may be reported by the MGW and shall be supported by the MSC as such by using H.248.1 error code #449 "Unsupported or Unknown Parameter or Property Value". **Error Text in the error Descriptor:** The unsupported or unknown value is included in the error text in the error descriptor.

Table 10.1: Additional parameters required

| | | |
|---|---------------------------|--|
| actprot | Signal descriptor | As for the signal "Activate protocol" in subclause 15. 2.1.3 |
| Mode | Local control | As for the property "UP mode of operation" in subclause 15.1.1.1 |
| Version | Local control | As for the property "Upversion" in subclause 15.1.1.1 |
| Value | Local control | As for the property " Delivery of erroneous SDUs" in subclause 15.1.1.1 |
| Interface | Local control | As for the property " Interface" in subclause 15.1.1.1 |
| Initdirection | Local control | As for the property " Initialization Direction" in subclause 15.1.1.1 |
| PLMN bearer capability | Local control | As for the property "PLMN BC" in subclause 15. 2.1.1 |
| | | |
| Coding | Local control | As for the property " GSM channel coding" in subclause 15. 2.1.1 |
| tfoactvalue | Local control | As for the property " TFO activity control" in subclause 15. 2.2.1 |
| Codeclist | Local control | As for the property " TFO Codec List" in subclause 15. 2.2.1 |
| Result | ObservedEvent descriptor | As for the ObservedEventDescriptor parameter "Protocol Negotiation Result" in subclause 15. 2.1.2 |
| Cause | ObservedEvent descriptor | As for the ObservedEventDescriptor parameter "Protocol Negotiation Result" in subclause 15. 2.1.2 |
| Rate | ObservedEvent descriptor | As for the ObservedEventDescriptor parameter "Rate Change" in subclause 15. 2.1.2 |
| Optimalcodec | ObservedEvent descriptor | As for the ObservedEventDescriptor parameter "Optimal Codec Type" in subclause 15. 2.2.2 |
| Distlist | ObservedEvent descriptor | As for the ObservedEventDescriptor parameter "Distant TFO List" in subclause 15. 2.2.2 |
| On/Off | Local control | As for the property "Echo cancelling" in subclause E.13.1 in ITU-T Recommendation H.248.1 [10] . Default value is Off. |
| Error | Error descriptor | As defined in the subclause "Command error code" in ITU-T Recommendation H.248.1 [10] |
| MGW Resource Congestion Handling - Indication | EventDescriptor | As for the EventDescriptor in subclause 4.2.1/H.248.10 "MGCongestion" |
| Reduction | ObservedEvent descriptor | As for the ObservedEventDescriptor in subclause 4.2.1/H.248.10 "MGCongestion".. |
| Bearer Modification Support | EventDescriptor | As for the EventsDescriptor in "Bearer Modification Support" in subclause 15. 2.3.2. |
| Bearer modification possible | ObservedEvent descriptor | As for the ObservedEventDescriptor in "Bearer Modification Support" in subclause 15. 2.3.2. |
| Ctmstate | TerminationState | As for the TerminationState "Text termination connection state" in subclause 15. 2.6.1. |
| Ctmtransport | Local control | As for the property "Text Transport" in subclause 15.2.6.1. |
| Ctmtext version | Local control | As for the property " Text Protocol Version" in subclause 15.2.6.1. |
| Connchnng | ObservedEventDescriptor | As for the ObservedEventDescriptor " Connection State Change in subclause 15.2.6.2 |
| Ctmbits | Statistics descriptor | As for the Statistics descriptor "Characters Transferred" in subclause 15.2.6.4 |
| Bitrate | Local control | As for the property " Bitrate" in subclause 15.1.7.1 |
| Ippaddress | Local control | As for the property " IP transport address" in subclause 15.2.7.1 |
| UDPport | Local control | As for the property " UDP port " in subclause 15.2.7.1 |
| Flexitone | Local control | As for the signal "Flexible Tone " in subclause 15.2.8.1 |
| Trace reference | Local control | As for the property "Trace Reference" in subclause 15.2.9.1 |
| Trace Recording Session Reference | Local control | As for the property "Trace Recording Session Reference" in subclause 15.2.1.1 |
| Trace Depth | Local control | As for the property "Trace Depth" in subclause 15.2.9.1 |
| Triggering events | Local control | As for the property "Triggering events" in subclause 15.2.9.1 |
| List of interfaces | Local control | As for the property "List of interfaces" in subclause 15.2.9.1 |
| IMSI | Local control | As for the property "IMSI" in subclause 15.2.9.1 |
| IMEI(SV) | Local control | As for the property "IMEI(SV)" in subclause 15.2.9.1 |
| Trace activativity request | Local control | As for the property "Trace Activation Control" in subclause 15.2.9.1 |
| Trace Activation Result | ObservedEvents descriptor | As for the ObservedEventDescriptor " Trace Activation result" in subclause 15.2.9.2 |

11 Mandatory Support of SDP and H.248.1 annex C information elements

This section shall be in accordance with the subclause "Mandatory Support of SDP and H.248.1 annex C information elements" in ITU-T Recommendation Q.1950 [23] (see 3GPP TS 29.205 [7]) with the following requirements:

- Mc Single Codec encoding:

The ACodec property in H.248 binary encoding and codeconfig attribute in H.248 text encoding are set as defined in ITU-T Recommendation Q.765.5 [24], for single codec information (figure 14/Q.765.5), where the Codec Information is defined either in ITU-T Recommendation Q.765.5 [24] or in another specification for the given Organization Identifier. For 3GPP codecs these are defined in 3GPP TS 26.103 [16]. The codeconfig and ACodec parameters contain the contents of the Single Codec IE, excluding the Single Codec Identifier, Length Indication and Compatibility Information.

The "vsel" attribute is omitted in H.248 text encoding.

Example of encoding of an AMR codec:

ACodec = 0206959504 (binary encoding)

codeconfig = 0206959504 (text encoding)

where the AMR parameters are: ETSI, UMTS_AMR_2, [ACS={4.75, 5.90, 7.4, 12.2}, SCS={4.75, 5.90, 7.4, 12.2}, OM=0, MACS=4]

Example of encoding of the G.711 codec:

ACodec = 0101 (binary encoding)

codeconfig = 0101 (text encoding)

NOTE: The "Mc Single Codec IE" differs from the ITU-T defined "Single Codec IE", while on the Nc interface (i.e. in OoBTC) the ITU-T Single Codec IE is used without deviation.

The ACodec property or codeconfig attribute set to the MuMe Dummy codec denotes a multimedia call. The ACodec property and codeconfig attribute shall never be set to the MuMe2 Dummy codec. See 3GPP TS 26.103 [16] and 3GPP TS 23.172 [36].

The content of the RNC Transport Address or BIWF Address depends on the used transport interface but the principle is that NSAP format is used. See 3GPP TS 25.414 [21] for RNC and for core network see 3GPP TS 29.414 [32]. For IP the IANA ICP IDI format of the NSAP addressing format as specified in X.213 [33] shall be used. For Ipv4 networks the Ipv4 format recommended by X.213 shall be adopted.

For this application the BIR length shall be fixed at 4 Octets and the NSAP length shall be fixed at 20 Octets.

12 General on Packages and Transactions

The base root package (0x0002) properties shall be provisioned in the MGW.

Event Buffering shall not be supported.

Error Descriptor in NotifyRequest shall not be used.

DigitMaps shall not be supported.

H.248 Statistics shall not be audited via the Mc interface and shall be suppressed in the replies to Subtract commands, except where specific 3GPP packages define their use.

Embedded Signals shall not be supported on the Mc interface.

Embedded Events shall not be supported on the Mc interface.

Only a single media stream per Termination shall be supported.

Stream ID in Topology Descriptor shall not be supported.

The use of "Overspecified" (e.g. range of values) and "Underspecified" (e.g. "?") parameter specification shall not be permitted except where explicitly indicated in or referenced by the Mc interface specification.

ServiceChange Method "Failover" with the "MG impending failure" reason shall not be used on this interface

ServiceChange Method "Handoff" involving more than 1 MSC or MGW shall not be used on this interface.

Note : This does not preclude the use of the MGCIId in a ServiceChange (Handoff) scenario, nor does it change the expected MG behaviour upon receipt of such a message, as the MGW has actually no means to differentiate whether the ServiceChangeMgcId parameter that may be received in a ServiceChange (handoff) message relates to a logical MGC inside the same MSC server or is part of another MSC-Server.

When ADD, MOD, or MOV commands exclude an Audit Descriptor, the MGW response shall only include descriptors which contained underspecified or overspecified properties in the command request, with the exception of the Error Descriptor. Furthermore, only those properties that were underspecified or overspecified in the request shall be sent in the reply.

Note1: This does not exclude tunnel information returned as part of the IPBCP tunnelling procedures.

Note2: The applicability of this restriction for text encoding is FFS.

The following Service Change Reasons are not supported:

- Modem Capability Failure (911)
- Mux Capability Failure (912).

The following MGW capabilities shall be supported by the Audit Capability procedure:

- FFS

When a Service Change command on the Root termination with a method other than Graceful is sent, the command shall always be sent as the only command in a message. The sending node shall always wait for the reply to a Service Change command on the Root termination with a method other than Graceful before sending further command requests. A Service Change command on the Root termination with method Graceful may be combined with other commands in a single message.

Signals on ROOT termination shall not be supported

Modem descriptor shall not be supported.

Multiplex descriptor shall not be supported.

An action request sent to a MG shall not include a request to audit attributes of a Context. Hence, for ASN.1 encoding ContextAttributeAuditReq shall not be used and for text encoding contextAudit attribute of a contextRequest shall not be used.

The ServiceState property within the TerminationState descriptor shall not take the value "Test".

The use of the Announcement Variant parameter is optional for both Fixed Announcements and Variable Announcements.

The use of wildcarding for the Termination Id shall be performed using 1 octet only.

Wildcarded responses shall only be used in Release procedures (Release Bearer and Release Termination), when multiple terminations are released with one command and in audit responses where multiple terminations are implied by the audit request.

Notifications shall not be sent by the MGW in response to Release Termination procedure.

Context Attribute Priority shall not be supported.

Stream Mode Loopback shall not be supported.

Parameter modification and event notification shall not be permitted on non-ROOT Terminations in the NULL Context. Commands on ROOT Termination shall only use the NULL Context.

13 BICC packages

13.1 Mandatory BICC packages

The following BICC packages shall be supported:

- Bearer Characteristics Package (see ITU-T Recommendation Q.1950 [23] annex A.3).
- Generic Bearer Connection Package (see ITU-T Recommendation Q.1950 [23] annex A.6).

13.2 Optional BICC packages

The following BICC packages shall be supported as required by the network services deployed in the network:

- Basic Call Progress Tones Generator with Directionality, (see ITU-T Recommendation Q.1950 [23] annex A.8).
- Expanded Call Progress tones Generator Package (see ITU-T Recommendation Q.1950 [23] annex A.9).
- Basic Services Tones Generation Package, (see ITU-T Recommendation Q.1950 [23] annex A.10).
- Bearer Control Tunnelling Package (see ITU-T Recommendation Q.1950 [23] annex A.7).
- Expanded Services Tones Generation Package (see ITU-T Recommendation Q.1950 [23] annex A.11).
- Intrusion Tones Generation Package (see ITU-T Recommendation Q.1950 [23] annex A.12).
- Business Tones Generation Package (see ITU-T Recommendation Q.1950 [23] annex A.13).

14 H.248 standard packages

The following H.248 packages shall be supported by this UMTS Capability Set:

- Generic v1 (see ITU-T Recommendation H.248.1 [10] annex E.1).
- Base Root Package v2 (see ITU-T Recommendation H.248.1 [10] annex E.2).
- Tone Detection Package v1 (see ITU-T Recommendation H.248.1 [10] annex E.4). This package is "for extension only" and shall not be published over the Mc interface.
- Basic DTMF Generator Package v1 (see ITU-T Recommendation H.248.1 [10] annex E.5). Only the DTMF Signal Ids shall be used, not the Tone Ids within the PlayTone Signal Id.
- DTMF Detection Package v1 (see ITU-T Recommendation H.248.1 [10] annex E.6).
- Generic Announcement Package v1 (see ITU-T Recommendation H.248.7 [28]) – Fixed Announcements.
- TDM Circuit Package v1 (see ITU-T Recommendation H.248.1 [10] annex E.13) , however Network Package (annex E.11) extended by this package shall not be supported
- Media Gateway Resource Congestion Handling Package v1 (see ITU-T Recommendation H.248.10 [15]).

The following H.248 packages may be supported by this UMTS Capability Set as required by the network services deployed in the network:

- Tone Generator Package v1 (see ITU-T Recommendation H.248.1 [10] annex E.3). This package is "for extension only" and shall not be published over the Mc interface.

- Generic Announcement Package v1 (see ITU-T Recommendation H.248.7 [28]) – Variable Announcements.
- Text Telephony Package (see ITU-T Recommendation H.248.2 [17]).
- Call Discrimination package v2 (see ITU-T Recommendation H.248.2 [17]).
- - Basic Continuity Package v1 (see ITU-T Recommendation H.248.1 [10] annex E.10).

14.1 Call independent H.248 transactions

Table 2 shows the relationship between each non call-related procedure in ITU-T Recommendation Q.1950 [23] (see 3GPP TS 29.205 [7]) and the corresponding stage 2 procedure defined in 3GPP TS 23.205 [2].

For further description of error codes and service change reasons, refer to ITU-T Recommendation H.248.8 [14].

Table 14.1.1: Correspondence between ITU-T Recommendation Q.1950 [23] non call-related transactions and 3GPP TS 23.205 [2] procedures

| Transaction used in ITU-T Recommendation Q.1950 [23] | Procedure defined in 3GPP TS 23.205 [2] | Support | Comments |
|--|---|-----------|---|
| BIWF_Service_Cancellation_Indication | MGW Out of Service | Mandatory | |
| BIWF_Lost_Communication | MGW Communication Up | Mandatory | |
| BIWF_Service_Restoration_Indication | MGW Restoration | Mandatory | |
| BIWF_Registration | MGW Register | Mandatory | |
| BIWF_Re-Registration | MGW Re-register | Mandatory | |
| CCU Ordered BIWF Re-Registration | (G)MSC Server Ordered Re-register | Mandatory | |
| CCU Initiated Service Restoration | (G)MSC Server Restoration | Optional | |
| CCU Initiated Service Cancellation | (G)MSC Server Out of Service | Optional | |
| BIWF_Service_Cancellation_Indication | Termination Out-of-Service | Mandatory | Is a part of BIWF Service cancellation in Q.1950 |
| BIWF_Service_Restoration_Indication | Termination Restoration | Mandatory | Is a part of BIWF Service cancellation in Q.1950 |
| Audit_Values | Audit Value | Mandatory | Shall be supported for the audit of Termination State and for periodic audit of MGW (empty Audit descriptor). May be supported for the audit of packages. |
| Audit_Capabilities | Audit Capability | Optional | The capabilities to be audited shall be defined in clause 12. |
| BIWF_Capability_Change | Capability Update | Optional | |
| | MGW Resource Congestion Handling - Activate | Mandatory | |
| | MGW Resource Congestion Handling - Indication | Mandatory | |
| Continuity Check Tone | | Optional | |
| Continuity Check Verify | | Optional | |
| Continuity Check Response | | Optional | |

14.1.1 MGW Out of service/Maintenance Locking

This procedure is the same as described in the subclause "BIWF Service Cancellation Indication" in ITU-T Recommendation Q.1950 [23] (see 3GPP TS 29.205 [7]), with the following clarification.

Table 14.1.1.1: MGW Out of service/Maintenance Locking

| Address Information | Control information | Bearer information |
|---------------------|--|--------------------|
| | Transaction ID = z Context ID = Null Termination ID = Root Service Change Reason = MGW impending failure Termination Taken out of service Service Change Method = Graceful / Forced | |

Delay is not used.

NOTE: The termination that is taken out of service is a Media Gateway.

14.1.2 MGW Communication Up

This procedure is the same as described in the subclause "BIWF Lost Communication" in ITU-T Recommendation Q.1950 [23] (see 3GPP TS 29.205 [7]) with the following clarification.

Use of time stamps is optional.

Context Id value Null shall be used in this procedure.

14.1.3 MGW Restoration

This procedure is the same as described in the subclause "BIWF Service Restoration Indication" in ITU-T Recommendation Q.1950 [23] (see 3GPP TS 29.205 [7]) with the following clarification.

Table 14.1.3: MGW Restoration

| Address Information | Control information | Bearer information |
|---------------------|--|--------------------|
| | Transaction ID = z Context ID = Null Termination ID = Root | |

Delay is not used.

14.1.4 MGW Register

This procedure is the same as that described in the subclause "BIWF Registration" in ITU-T Recommendation Q.1950 [23] (see 3GPP TS 29.205 [7]) with the following clarification.

14.1.4: MGW Register

| Address Information | Control information | Bearer information |
|---------------------|---|--------------------|
| | ServiceChangeProfile = mcprofilename / version | |

Use of time stamps is optional.

Context Id value Null shall be used in this procedure.

Non Standard Data is shall not be supported.

Service Change Address shall not be used.

14.1.5 MGW Re-register

This procedure is the same as that described in the subclause "BIWF Re-Registration" in ITU-T Recommendation Q.1950 [23] (see 3GPP TS 29.205 [7]) with the following clarification.

Table 14.1.5.1: MGW Re-register

| Address Information | Control information | Bearer information |
|---------------------|---|--------------------|
| | ServiceChangeProfile = mcprofilename / version | |

Use of time stamps is optional.

Context Id value Null shall be used in this procedure.

Non Standard Data is shall not be supported.

Service Change Address shall not be used.

14.1.6 (G)MSC Server Ordered Re-register

This procedure is the same as described in the subclause "CCU Ordered BIWF Re-registration" in ITU-T Recommendation Q.1950 [23] (see 3GPP TS 29.205 [7]) with the following clarifications:

Context Id value Null shall be used in this procedure.

14.1.7 (G)MSC Server Restoration

This procedure is the same as described in the subclause "CCU Initiated Service Restoration" in ITU-T Recommendation Q.1950 [23] (see 3GPP TS 29.205 [7]) with the following clarification.

Table 14.1.7.1: (G)MSC Server Restoration

| Address Information | Control information | Bearer information |
|---------------------|---|--------------------|
| | Context ID = Null Termination ID = Root Service Change Reason = Cold Boot / Warm Boot Service Change Method = Restart | |

Delay is not used.

14.1.8 Termination Out-of-Service

This procedure is the same as described in the subclause "BIWF Service Cancellation Indication" in ITU-T Recommendation Q.1950 [23] (see 3GPP TS 29.205 [7]) with the following clarifications. This procedure may be used to inform the MSC Server of the Service State of Terminations after MGW Restart or Registration.

Table 14.1.8:ServiceChange.req (Termination Out-of-Service) MGW to MGC

| Address Information | Control information | Bearer information |
|---------------------|---|--------------------|
| | Transaction ID = z Context ID = Contexts / Null / All Termination ID = ALL/Termination(s) Service Change Reason = Transmission failure / Termination malfunctioning / Loss of lower layer connectivity / Termination taken out of service Service Change Method = Graceful / Forced NOTE1: "All" shall refer to 1 TDM group. 1 TDM group is at a T1/E1. | |

Delay is not used.

14.1.9 Termination Restoration

This procedure is the same as described in the subclause "BIWF Service Restoration Indication" in ITU-T Recommendation Q.1950 [23] (see 3GPP TS 29.205 [7]) with the following clarification This procedure may be used to inform the MSC Server of the Service State of Terminations after MGW Restart or Registration and shall be used when individual trunks are commissioned.

Table 14.1.9: Termination Restoration

| Address Information | Control information | Bearer information |
|---------------------|--|--------------------|
| | Transaction ID = z Context ID = Contexts / Null / All Termination ID = ALL/Termination(s) Service Change Reason = Service Restored Service Change Method = Restart NOTE1: "All" shall refer to 1 TDM group. 1 TDM group is at a T1/E1. | |

Delay shall not be used.

14.1.10 Audit Value

This procedure is the same as described in the subclause "Audit Values" in ITU-T Recommendation Q.1950 [23] (see 3GPP TS 29.205 [7]), with the following clarifications . This procedure shall be used by the MSC Server to determine the service state of physical terminations when the MSC Server itself has restarted if it is subsequently unsure of the service state of terminations or when O&M procedures indicate new physical trunks have been commissioned to an in service MGW. It shall also be used for determining the Termination State after MGW Registration (Cold Boot) prior to deblocking devices in the network if the MSC Server has not been informed specifically by Termination Restoration or Termination Out Of Service Procedure.

Table 14.1.10.1: AUD_VAL.req (Audit_Values) MGC to MGW

| Address Information | Control information | Bearer information |
|---------------------|--|--------------------|
| | Transaction ID = z Context ID = Null/Context ID/ALL Termination ID = Termination/Root/ALL(see NOTE1) Audit Descriptor = Empty/ IndAuditParameter:= IndAudMediaDescriptor:= TermStateDescriptor (NOTE3) Packages (See NOTE2) NOTE1: "All" shall refer to 1 TDM group. 1 TDM group is at a T1/E1 level It shall not be used for ATM or IP termination. "Termination" shall only be used for individual IP or ATM terminations, not TDM. NOTE2: Packages is only for Null/Root Combination NOTE3: Pre Rel6 this is performed with Audit Token | |

Upon reception of the command in the MGW:

- The Service State returns the current Service State
- When Packages are requested, the Package Names and Versions are returned

The following table illustrates the allowed combinations that can be obtained with the AuditValue Command:

Table 14.1.10.2: Combinations of AuditValue Command

| ContextID | TerminationID | Information Obtained |
|-----------|---------------|---|
| Specific | Wildcard | Audit of matching Terminations in a Context |
| Specific | Specific | Audit of a single Termination in a Context |
| Null | Root | Audit of Media Gateway state and events |

| | | |
|------|----------|---|
| Null | Wildcard | Audit of all matching TDM T1/E1 level Terminations in the null Context |
| Null | Specific | Audit of a single Termination outside of any Context |
| All | Wildcard | Audit of all matching TDM T1/E1 level Terminations and the Context to which they are associated |
| All | Specific | (Non-null) ContextID in which the Termination currently exists |

Table 14.1.10.3: AUD_VAL.resp MGW to MGC

| Address Information | Control information | Bearer information |
|---------------------|---|--------------------|
| | Transaction ID = z Context ID = Null/Context ID Termination ID = Termination/Root/All(seeNOTE1) <u>Empty Audit Descriptor:</u> - <u>AuditToken =</u> <u>Media/IndAudMediaDescriptor=TermStateDescriptor:</u> Service State = Current Service State <u>AuditToken = Packages:</u> Packages Descriptor = Package Names + Versions NOTE1: ALL may be returned for a TDM group. | |

14.1.11 Audit Capability

This procedure is the same as described in the subclause "Audit Capabilities" in ITU-T Recommendation Q.1950 [23] (see 3GPP TS 29.205 [7]).

14.1.12 MGW Capability Change

This procedure is the same as described in the subclause "BIWF Capability Change" in ITU-T Recommendation Q.1950 [23] (see 3GPP TS 29.205 [7]).

14.1.13 (G)MSC Server Out of Service

This procedure is the same as that described in the subclause "CCU Initiated Service Cancellation" in ITU-T Recommendation Q.1950 [23] (see 3GPP TS 29.205 [7]) with the clarification that Delay shall not be used.

14.1.14 MGW Resource Congestion Handling - Activate

If the procedure "MGW Resource Congestion Handling - Activate" is required the following procedure is initiated.

The MGC sends a MOD.req command with the following information.

Table 14.1.14.1: MOD.req(MGW Resource Congestion Handling - Activate) MGC to MGW

| Address Information | Control information | Bearer information |
|---------------------|---|--------------------|
| | Transaction ID = z Context ID = Null Termination ID = Root NotificationRequested (Event ID = x, "MGW Resource Congestion Handling - Indication") | |

When the processing of command (1) is complete, the MGW initiates the following procedure.

Table 14.1.14.2: MOD.resp (MGW Resource Congestion Handling - Activate) MGW to MGC

| Address Information | Control information | Bearer information |
|---------------------|---|--------------------|
| | Transaction ID = z Context ID = Null TerminationID = Root | |

14.1.15 MGW Resource Congestion Handling - Indication

If the procedure "MGW Resource Congestion Handling - Indication" is required, the following procedure is initiated:

The MGW sends a NOT.req command with the following information.

Table 14.1.15.1: NOT.req (MGW Resource Congestion Handling - Indication) MGW to MGC

| Address Information | Control information | Bearer information |
|---------------------|--|--------------------|
| | Transaction ID = z Context ID = Null Termination ID = Root Event_ID (Event ID = x, "MGW Resource Congestion Handling - Indication (Reduction)") | |

When the processing of command (1) is complete, the MGW initiates the following procedure.

Table 14.1.15.2: NOT.resp (MGW Resource Congestion Handling - Indication) MGC to MGW

| Address information | Control information | Bearer information |
|---------------------|--|--------------------|
| | Transaction ID = z Context ID = Null Termination ID = Root | |

14.1.16 Continuity Check Tone

This procedure is the same as described in Annex B.7.1.1 of ITU-T Recommendation Q.1950 [10] with the following clarification:

The addition to "Prepare BNC Notify" defined in Annex B.7.1.1 of ITU-T Recommendation Q.1950 [10] shall be applied instead to "Reserve Circuit", as defined in Clause 13.2.2.1

NOTE: This does not preclude the use of the continuity check tone for other maintenance procedures. If the termination is audited it shall report state in service.

14.1.17 Continuity Check Verify

This procedure is the same as described in Annex B.7.2.1 of ITU-T Recommendation Q.1950 [10]

14.1.18 Continuity Check Response

This procedure is the same as described in Annex B.7.1.2 of ITU-T Recommendation Q.1950 [10] with the following clarification:

The addition to "Prepare BNC Notify" defined in Annex B.7.1.2 of ITU-T Recommendation Q.1950 [10] shall be applied instead to "Reserve Circuit", as defined in Clause 13.2.2.1

Note: This does not preclude the use of the continuity check response for other maintenance procedures. If the termination is audited is shall report state in service.

14.2 Call related H.248 transactions

Table 14.2.1 shows the relationship between each call-related procedure in ITU-T Recommendation Q.1950 [23] (see 3GPP TS 29.205 [7]) and the corresponding stage 2 procedure defined in 3GPP TS 23.205 [2], as well as specifying the requirement for support of each procedure on the Mc interface.

Table 14.2.1: Correspondence between ITU-T Recommendation Q.1950 [23] call-related transactions and 3GPP TS 23.205 [2] and 3GPP TS 23.153 [1] procedures

| Transaction used in Q.1950 | Procedure defined in 3GPP TS 23.205 [2] and 23.153 [1] | Support | Comments |
|---------------------------------------|---|-----------|---|
| Change_Topology | Change Flow Direction | Mandatory | |
| Join | Join Bearer Termination | Mandatory | |
| Isolate | Isolate Bearer Termination | Mandatory | |
| Establish_BNC_Notify+(tunnel) | Establish Bearer | Mandatory | |
| Prepare_BNC_Notify+(tunnel) | Prepare Bearer | Mandatory | |
| Cut_Through | Change Through Connection | Mandatory | |
| Not defined in Q.1950 | Activate Interworking Function | Optional | |
| Cut_BNC (include several procedures). | Release Bearer (Release Bearer and Release termination) | Mandatory | |
| BNC Established | Bearer Established | Mandatory | |
| BNC Release | Bearer Released | Mandatory | |
| Insert_Tone | Send Tone | Mandatory | |
| Insert_Announcement | Play Announcement | Mandatory | |
| Signal Completion | Announcement Completed | Mandatory | |
| Detect_Digit | Detect DTMF | Mandatory | |
| Insert_Digit | Send DTMF | Mandatory | |
| Digit Detected | Report DTMF | Mandatory | |
| Confirm_Char | Confirm Char | Optional | |
| Modify_Char | Modify Char | Optional | |
| Reserve_Char | Reserve Char | Optional | |
| BNC Modified | Bearer Modified | Optional | |
| Echo Canceller | Activate Voice Processing Function | Mandatory | |
| BNC Modification failed | Bearer Modified Failed | Optional | |
| Tunnel (MGC-MGW) | Tunnel Information Down | Optional | Shall be supported if the Nb interface transport protocol is IP |
| Tunnel (MGW-MGC) | Tunnel Information Up | Optional | Shall be supported if the Nb interface transport protocol is IP |
| Insert_Tone | Stop Tone | Mandatory | |
| Insert_Announcement | Stop Announcement | Mandatory | |
| Detect_Digit | Stop DTMF Detection | Optional | |
| Insert_Digit | Stop DTMF | Mandatory | |
| Signal Completion | Tone Completed | Optional | |
| Not defined | Reserve Circuit | Mandatory | |
| Not defined | Command Rejected | Mandatory | |
| Not defined | TFO Activation | Optional | |
| Not defined | Codec Modify | Optional | |
| Not defined | Optimal Codec and Distant List_Notify | Optional | |
| Not defined | Distant Codec List | Optional | |
| Not defined | TFO status Notify | Optional | |
| Not defined | TFO status | Optional | |
| Modify_Char | Modify Bearer Characteristics | Mandatory | |
| Not defined | Rate Change | Optional | |
| Not defined | Bearer Modification Support | Optional | |
| Not defined | Protocol Negotiation Result | Optional | |
| Reserve_Char | Reserve Bearer Characteristics | Optional | |
| Confirm_Char | Confirm Bearer Characteristics | Optional | |
| ECS_Indication | Emergency Call Indication | Optional | |
| Continuity Check Tone | Continuity Check Tone | Optional | See 14.1.16 |
| Continuity Check Verify | Continuity Check Verify | Optional | See 14.1.17 |
| Continuity Check Response | Continuity Check Response | Optional | See 14.1.18 |
| Not Defined | Prepare IP Transport | Optional | Shall be supported if IP used on lu interface |
| Not Defined | Modify IP Transport Address | Optional | Shall be supported if IP used on lu interface |

NOTE: A procedure defined in table 3 can be combined with another procedure in the same action. This means that they can share the same contextID and termination ID(s).

14.2.1 Change Flow Direction

This procedure is the same as that defined in the subclause "Change Connection Topology" in ITU-T Recommendation Q.1950 [23] (see 3GPP TS 29.205 [7]) with the following additions.

Table 14.2.1.1: Change Flow Direction request additions

| Address Information | Control information | Bearer information |
|---------------------|---|--------------------|
| | Context ID = c1,? Connection Configuration = (TerminationID= x1, ? TerminationID=x2,? [type = x]),... | |

This procedure shall not be used for Multiparty bridge contexts.

The Change Flow Direction response shall contain the Context ID.

A command is only required if this procedure is combined with some other procedure which changes a termination functionality.

14.2.2 Isolate Bearer Termination

This procedure is the same as that defined in the subclause "Isolate" in ITU-T Recommendation Q.1950 [23] (see 3GPP TS 29.205 [7]).

14.2.3 Join Bearer Termination

This procedure is the same as that defined in the subclause "Join" in ITU-T Recommendation Q.1950 [23] (see 3GPP TS 29.205 [7]).

14.2.4 Establish Bearer

This procedure is the same as that defined in the subclause "Establish BNC_notify" in ITU-T Recommendation Q.1950 [23] (see 3GPP TS 29.205 [7]) except that the Command MOV shall not be used and with additions as shown below. If IPBCP Tunnel Option 1 is required then the Command Response shall always precede the IPBCP Notify Command.

Table 14.2.4.1: Establish Bearer additions

| Address Information | Control information | Bearer information |
|---|---|---|
| | UP mode = Mode UP version = version Delivery of erroneous SDUs = value Interface = interface If support mode: Initdirection = initdir If indication on Protocol Negotiation Result requested: NotificationRequested (Event ID = x, "Prot Negotiation Result") If indication on Rate Change requested: NotificationRequested (Event ID = x, "RateChange") | If SCUDIF multimedia call : MuMe codec (NOTE 1) If data call other than SCUDIF multimedia call and Access Termination or Anchor MGW Network Termination: PLMN bearer capability = PLMN capability (NOTE2) If GSM data call and (Anchor MGW Network Termination: GSM channel coding = coding |
| NOTE1: Bearer Service Characteristics shall be excluded when this property is included. | | |
| NOTE2: Bearer Service Characteristics may be included. | | |

14.2.5 Prepare Bearer

This procedure is the same as that defined in the subclause "Prepare_BNC_notify" in ITU-T Recommendation Q.1950 [23] (see 3GPP TS 29.205 [7]) except that the Commands MOD and MOV shall not be used, the MGW shall not choose the BNC Characteristics, the BNC-cut-through-capability shall not be used and with additions as shown below.

Table 14.2.5.1: Prepare Bearer additions

| Address Information | Control information | Bearer information |
|--|--|---|
| | UP mode = mode UP version = version Delivery of erroneous SDUs = value Interface = interface If support mode: Initdirection = initdir State= ctmstate Transport= ctmtransport Version= ctmtext version If data call and Non-Anchor MGW RAN-side termination: Bitrate = bitrate (NOTE1) If indication on Protocol Negotiation Result requested: NotificationRequested (Event ID = x, "Prot Negotiation Result") If indication on Rate Change requested: NotificationRequested (Event ID = x, "RateChange") If indication on Bearer Modification requested: NotificationRequested (Event ID = x, "Bearer Modification Support") If notification on CTM negotiation result requested: NotificationRequested (Event ID = x, " connchange ") | If SCUDIF multimedia call and (network termination or Anchor MGW Access Termination): MuMe codec (NOTE 2) If data call other than SCUDIF multimedia call and (Anchor MGW Access Termination or Anchor MGW Network Termination): PLMN bearer capability = PLMN capability (NOTE3) If GSM data call other than SCUDIF multimedia call and Anchor MGW Network Termination: GSM channel coding = coding |
| NOTE1 : Bearer Service Characteristics shall be excluded when this property is included except for the case when bitrate = 64000 and then Bearer Service Characteristics may be included. Bitrate is optional for transparent data calls when the data rate is 64k bits/s. NOTE2: Bearer Service Characteristics shall be excluded when this property is included. NOTE3: Bearer Service Characteristics shall be excluded when this property is included, except for Anchor MGW network termination for which it may be included. | | |

14.2.6 Change Through Connection

This procedure is the same as that defined in the subclause "Cut Through" in ITU-T Recommendation Q.1950 [23] (see 3GPP TS 29.205 [7]) with the following clarification and deletion.

The BIWF controlled cut through, as defined in the subclause "Cut Through" - "BIWF controlled" in ITU-T Recommendation Q.1950 [23] (see 3GPP TS 29.205 [7]), is used as well as the MGC controlled cut through for the change through connection procedure.

NotificationRequested = (Event ID = x, "Cut Through") is deleted.

14.2.7 Activate Interworking Function

When the procedure "Activate Interworking Function" is required the following procedure is initiated:

The MGC sends a MOD.req command with the following information.

Table 14.2.7.1: MOD.req (Activate Interworking function) MGC to MGW

| Address Information | Control information | Bearer information |
|---------------------|---|--------------------|
| | Transaction ID = z Context ID = c1 Termination ID = bearer1 Signal=actpro If indication on Protocol Negotiation Result requested: NotificationRequested (Event ID = x, "Prot Negotiation Result") If indication on Rate Change requested: NotificationRequested (Event ID = x, "RateChange") | |

When the processing of command (1) is complete, the MGW initiates the following procedure.

Table 14.2.7.2: MOD.resp (Activate Interworking function) MGW to MGC

| Address Information | Control information | Bearer information |
|---------------------|--|--------------------|
| | Transaction ID = z Context ID = c1 TerminationID = bearer1 | |

14.2.8 Release procedures

This subclause includes a number of procedures.

14.2.8.1 Release Bearer

This procedure is the same as that defined in the subclause "Release" in ITU-T Recommendation Q.1950 [23] (see 3GPP TS 29.205 [7]) including the Modify command in the transaction with the clarification that the Termination ID and/or Context ID may be wildcarded (ALL).

14.2.8.2 Release Termination

This procedure is the same as that defined in the subclause "Release" in ITU-T Recommendation Q.1950 [23] (see 3GPP TS 29.205 [7]) including a Subtract command in the transaction with the following additions.

Table 14.2.8.1 Sub.req (Release termination) MGC to MGW

| Address Information | Control information | Bearer information |
|---------------------|---|--------------------|
| | Transaction ID = z Context ID = c1/ALL Termination ID = bearer1/ALL | |

Table 14.2.8.2.2: Sub.resp (Release termination) MGW to MGC

| Address Information | Control information | Bearer information |
|---------------------|---|--------------------|
| | Transaction ID = z Context ID = c1/ALL Termination ID = bearer1/ALL If requested Statistics= Ctm bits | |

14.2.9 Bearer Released

This procedure is the same as that defined in the subclause "BNC Release" in ITU-T Recommendation Q.1950 [23] (see 3GPP TS 29.205 [7]) with the following clarification:

Termination ID shall be provided in the response.

14.2.10 Bearer Established

This procedure is the same as that defined in the subclause "BNC Established" in ITU-T Recommendation Q.1950 [23] (see 3GPP TS 29.205 [7]) with the following clarification:

Termination ID shall be provided in the response.

14.2.11 Send Tone

This procedure is the same as that defined in the subclause "Media Content Insertion" - "Insert Tone" in ITU-T Recommendation Q.1950 [23] (see 3GPP TS 29.205 [7]) with the following additions.

Table 14.2.11.1: Send Tone additions

| Address Information | Control information | Bearer information |
|---------------------|---|--------------------|
| | If CAMEL Prepaid Warning Tone Signal = warning tone Or Signal = flextone | |

Signal Direction shall be either "internal" or "external".

Only the Tone Signal Ids shall be used, not the Tone Ids within the PlayTone Signal Id.

14.2.12 Play Announcement

This procedure is the same as that defined in the subclause "Media Content Insertion" - "Insert Announcement" in ITU-T Recommendation Q.1950 [23] (see 3GPP TS 29.205 [7]) with the following clarifications:

Signal Direction shall be either "internal" or "external".

Stream mode may be maintained as for the ongoing call or may be changed be restricted to "send only".

Signal Lists shall be supported.

14.2.13 Send DTMF

This procedure is the same as that defined in the subclause "Media Content Insertion" - "Insert Digit" in ITU-T Recommendation Q.1950 [23] (see 3GPP TS 29.205 [7]). The MGW shall ensure the minimum duration timing and minimum interval timing is achieved in accordance with the DTMF timing defined in TS 23.014 [27]. Maximum duration shall also be controlled by the MGW if required by the network.

14.2.14 Detect DTMF

This procedure is the same as that defined in the subclause "Media Content Detection" - "Detect Digit" in ITU-T Recommendation Q.1950 [23] (see 3GPP TS 29.205 [7]) with the exception that "long tone detected" (Event Id ltd) shall not be used. In addition "start tone detected" (EventId std) is optional and if not supported shall result in the command error code #449 "Unsupported or Unknown Parameter or Property Value". If both a request for "start tone detected" and "end tone detected" is received by the MGW that does not support "start tone detected" then it shall only report a notification upon detecting the end of a digit.

Parameter *Duration* shall not be used.

All digits shall be requested i.e. Tone_Id shall be wildcarded.

14.2.15 Report DTMF

This procedure is the same as that defined in the subclause "Detected Digit" in ITU-T Recommendation Q.1950 [23] (see 3GPP TS 29.205 [7]) with the following clarification:

Termination ID shall be provided in the response.

14.2.16 Announcement Completed

This procedure is the same as that defined in the subclause "Signal Completion" in ITU-T Recommendation Q.1950 [23] (see 3GPP TS 29.205 [7]) with the following clarification:

Termination ID shall be provided in the response.

The Signal List ID should be provided additionally if the completed Announcement belongs to a Signal List.

14.2.17 Activate Voice Processing Function

When the procedure "Activate Voice Processing Function" (VPF) is required the following procedure is initiated:

The MGC sends an ADD.req, MOD.req or MOV.req command with the following information.

Table 14.2.17.1: ADD.req/MOD.req/MOV.req (Activate Voice Processing Function) MGC to MGW

| Address Information | Control information | Bearer information |
|---------------------|---|--------------------|
| | Transaction ID = z Context ID = c1 Termination ID = bearer1 ActivateVPF "ec"= on/off | |

When the MGW receives the command, it shall associate the relevant voice processing function resources with the specified termination.

When the processing of command (1) is complete, the MGW may initiate the "Voice Processing Function Ack" procedure.

14.2.17.2: ADD.resp/MOD.resp/MOV.resp (Voice Processing Function Ack) MGW to MGC

| Address Information | Control information | Bearer information |
|---------------------|---|--------------------|
| | Transaction ID = z Context ID = c1 Termination ID = bearer1 | |

14.2.18 Reserve Circuit

This procedure is activated when the "Reserve Circuit" procedure is initiated.

An ADD.req command is sent with the following information.

Table14.2.18.1: ADD.req (Reserve_Circuit) CSM to BIWF

| Address Information | Control information | Bearer information |
|---------------------|--|---|
| | Transaction ID = z Termination ID = bearer1 Context Requested: Context ID = ? Context Provided: Context ID = c1 State= ctmstate Transport= ctmtransport Version= ctmtext version If indication on Protocol Negotiation Result requested: NotificationRequested (Event ID = x, "Prot Negotiation Result") If indication on Rate Change requested: NotificationRequested (Event ID = x, "RateChange") If notification on CTM negotiation result requested: NotificationRequested (Event ID = x, " connchange ") If indication on Bearer Released requested: NotificationRequested (Event ID = x, "BNC Release (Cause)" – as defined in ITU-T Recommendation Q.1950 [23] | Bearer Service Characteristics If data call, Access Termination: PLMN capabilities If GSM data call, Access Termination: GSM channel coding = coding |

Upon completion of processing command (1) an ADD.resp command (2) is sent.

Table14.2.18.2: ADD.resp BIWF to CSM

| Address Information | Control information | Bearer information |
|---------------------|--|--------------------|
| | Transaction ID = z Context ID = c1 TerminationID = bearer1 | |

14.2.19 Tunnel Information Up

This procedure is the same as that defined in the subclause "Tunnel" in ITU-T Recommendation Q.1950 [23] (see 3GPP TS 29.205 [7]) with the clarification that BT/TunOpt = ? and BT/TunOpt = NO shall not be used.

NOTE: This procedure is always initiated from the MGW.

14.2.20 Tunnel Information Down

This procedure is the same as that defined in the subclause "Tunnel" in ITU-T Recommendation Q.1950 [23] (see 3GPP TS 29.205 [7]) with the clarification that BT/TunOpt = ? and BT/TunOpt = NO shall not be used.

NOTE: This procedure is always initiated from the MGC.

14.2.21 Tone Completed

This procedure is the same as that defined in the subclause "Signal.Completion" in ITU-T Recommendation Q.1950 [23] (see 3GPP TS 29.205 [7]) with the following clarification:

Termination ID shall be provided in the response.

14.2.22 Stop Announcement

This procedure is the same as that defined in the subclause "Insert Announcement" in ITU-T Recommendation Q.1950 [23] (see 3GPP TS 29.205 [7]) with the following clarification. The signal descriptor shall not include any signal.

14.2.23 Stop Tone

This procedure is the same as that defined in the subclause "Insert Tone" in ITU-T Recommendation Q.1950 [23] (see 3GPP TS 29.205 [7]) with the following clarification. The signal descriptor shall not include any signal.

14.2.24 Stop DTMF Detection

This procedure is the same as that defined in the subclause "Detect Digit" in ITU-T Recommendation Q.1950 [23] (see 3GPP TS 29.205 [7]) with the following clarification. The eventDescriptor shall not include any event.

14.2.25 Stop DTMF

This procedure is the same as that defined in the subclause "Media Content Insertion" - "Insert Digit" in ITU-T Recommendation Q.1950 [23] (see 3GPP TS 29.205 [7]). The signal descriptor shall not include any signal. The MGW shall ensure the minimum duration timing and minimum interval timing is achieved in accordance with the DTMF timing defined in TS 23.014 [27]. Maximum duration shall also be controlled by the MGW if required by the network.

14.2.26 Confirm Char

This procedure is the same as that defined in the subclause "Confirm Char" in ITU-T Recommendation Q.1950 [23] (see 3GPP TS 29.205 [7]).

14.2.27 Modify Char

This procedure is the same as that defined in the subclause "Modify Char" in ITU-T Recommendation Q.1950 [23] (see 3GPP TS 29.205 [7]).

14.2.28 Reserve Char

This procedure is the same as that defined in the subclause "Reserve Char" in ITU-T Recommendation Q.1950 [23] (see 3GPP TS 29.205 [7]).

14.2.29 Bearer Modified

This procedure is the same as that defined in the subclause "BNC Modified" in ITU-T Recommendation Q.1950 [23] (see 3GPP TS 29.205 [7]).

14.2.30 Bearer Modification Failed

This procedure is the same as that defined in the subclause "BNC Modification failure" in ITU-T Recommendation Q.1950 [23] (see 3GPP TS 29.205 [7]).

14.2.31 TFO Activation

When the procedure "TFO activation" is required the following procedure is initiated:

The MGC sends a ADD.req, MOD.req or MOV.req command with the following information.

Table 14.2.31.1: ADD.req/MOD.req/MOV.req (TFO activation) MGC to MGW

| Address Information | Control information | Bearer information |
|---------------------|---|--------------------|
| | Transaction ID = z Context ID = c1 Termination ID = bearer1 tfoenable = tfoactvalue If TFO codec list: Property= codeclist | |

When the processing of command (1) is complete, the MGW initiates the following procedure.

Table 14.2.31.2: ADD.resp/MOD.resp/MOV.resp (TFO activation) MGW to MGC

| Address Information | Control information | Bearer information |
|---------------------|--|--------------------|
| | Transaction ID = z Context ID = c1 TerminationID=bearer1 | |

14.2.32 Optimal Codec and Distant List_Notify

When the procedure "Optimal Codec and Distant List" is required the following procedure is initiated:

The MGC sends a ADD.req, MOD.req or MOV req. command with the following information.

Table 14.2.32.1: ADD.req/MOD.req/MOV.req (Codec modify and distant list) MGC to MGW

| Address Information | Control information | Bearer information |
|---------------------|--|--------------------|
| | Transaction ID = z Context ID = c1 Termination ID = bearer1 Property= codeclist NotificationRequested (Event ID = x, "Codec modify") NotificationRequested (Event ID = x, "Distant List") | |

When the processing of command (1) is complete, the MGW initiates the following procedure.

Table 14.2.32.2: ADD.resp/MOD.resp/MOV.resp (Optimal codec and codec list) MGW to MGC

| Address Information | Control information | Bearer information |
|---------------------|---|--------------------|
| | Transaction ID = z Context ID = c1 TerminationID= bearer1 | |

14.2.33 Codec Modify

When the procedure "Codec Modify" is required the following procedure is initiated:

The MGW sends a NOT.req command with the following information.

Table 14.2.33.1: NOT.req (Codec modify) MGW to MGC

| Address Information | Control information | Bearer information |
|---------------------|---|--------------------|
| | Transaction ID = z Context ID = c1 Termination ID = bearer1 Event_ID (Event ID = x, "Optimal codec") | |

When the processing of command (1) is complete, the MGW initiates the following procedure.

Table 14.2.33.2: NOT.resp (Codec modify) MGC to MGW

| Address Information | Control information | Bearer information |
|---------------------|---|--------------------|
| | Transaction ID = z Context ID = c1 Termination ID = bearer1 | |

14.2.34 Distant Codec List

When the procedure "Distant Codec List" is required the following procedure is initiated:

The MGW sends a NOT.req command with the following information.

Table 14.2.34.1: NOT.req (Distant codec list) MGW to MGC

| Address Information | Control information | Bearer information |
|---------------------|--|--------------------|
| | Transaction ID = z Context ID = c1 Termination ID = bearer1 Event_ID (Event ID = x, "Distant list") | |

When the processing of command (1) is complete, the MGW initiates the following procedure.

Table 14.2.34.2: NOT.resp (Distant codec list) MGC to MGW

| Address Information | Control information | Bearer information |
|---------------------|---|--------------------|
| | Transaction ID = z Context ID = c1 Termination ID = bearer1 | |

14.2.35 Command Rejected

When the procedure "Command Reject" is required the following procedure is initiated:

The MGW/MGC sends .resp to any command.req with the following information.

Table 14.2.34.1: NYcommand.resp (command reject) GW/MGC to MGC/MGW

| Address Information | Control information | Bearer information |
|---------------------|---|--------------------|
| | Transaction ID = z Context ID = c1 or no context Reason=Error | |

14.2.36 Modify Bearer Characteristics

This procedure is the same as that defined in the subclause "Modify Char" in ITU-T Recommendation Q.1950 [23] (see 3GPP TS 29.205 [7]) with additions as shown below.

Table 14.2.36.1: Modify bearer Characteristics additions

| Address Information | Control information | Bearer information |
|--|---|--|
| | If framing protocol used: UP mode = mode UPversion =version Delivery of erroneous SDUs=value Interface=interface If support mode: Initdirection=initdir If data call and Non-Anchor MGW RAN-side termination: Bitrate = bitrate (NOTE1) If indication on Protocol Negotiation Result requested: NotificationRequested (Event ID = x, "Prot Negotiation Result") If indication on Rate Change requested: NotificationRequested (Event ID = x, "RateChange") | If SCUDIF multimedia call and (network termination or Anchor MGW Access Termination): MuMe codec (NOTE 2) If data call other than SCUDIF multimedia call and (Anchor MGW Access Termination or Anchor MGW Network Termination):: PLMN bearer capbility = PLMN capability (NOTE3) If GSM data call other than SCUDIF multimedia call and Anchor MGW Network Termination: GSM channel coding=coding |
| NOTE1 : Bearer Service Characteristics shall be excluded when this property is included except for the case when bitrate = 64000 and then Bearer Service Characteristics may be included. Bitrate is optional for transparent data calls when the data rate is 64k bits/s. NOTE2: Bearer Service Characteristics shall be excluded when this property is included. NOTE3: Bearer Service Characteristics shall be excluded when this property is included, except for Anchor MGW network termination for which it may be included. | | |

If the "Modify Bearer Characteristics" procedure contains a codec that is not currently in use at the Termination when it receives this procedure, and if the framing protocol is used in support mode, the MGW shall be prepared to handle a framing protocol initialisation. If the "Modify Bearer Characteristics" contains no codec or the codec that is already in use at the Termination when it receives this procedure, the MGW does not need to be prepared to handle a framing protocol initialisation.

14.2.37 Protocol Negotiation Result

When the procedure "Protocol Negotiation Result" is required the following procedure is initiated:

The MGW sends a NOT.req command with the following information.

Table 14.2.37.1: NOT.req (Protocol negotiation result) MGW to MGC

| Address Information | Control information | Bearer information |
|---------------------|--|--------------------|
| | Transaction ID = z Context ID = c1 Termination ID = bearer1 Event_ID (Event ID = x, "Result", "Cause") | |

When the processing of command (1) is complete, the MGW initiates the following procedure.

Table 14.2.37.2: NOT.resp (Protocol negotiation result) MGC to MGW

| Address Information | Control information | Bearer information |
|---------------------|---|--------------------|
| | Transaction ID = z Context ID = c1 Termination ID = bearer1 | |

14.2.38 Rate Change

When the procedure "Rate Change" is required the following procedure is initiated:

The MGW sends a NOT.req command with the following information.

Table 14.2.38.1: NOT.req (Rate change) MGW to MGC

| Address Information | Control information | Bearer information |
|---------------------|--|--------------------|
| | Transaction ID = z Context ID = c1 Termination ID = bearer1 Event_ID (Event ID = x, "Rate") | |

When the processing of command (1) is complete, the MGW initiates the following procedure.

Table 14.2.38.2: NOT.resp (Rate change) MGC to MGW

| Address Information | Control information | Bearer information |
|---------------------|---|--------------------|
| | Transaction ID = z Context ID = c1 Termination ID = bearer1 | |

14.2.39 Bearer Modification Support

When the procedure "Bearer Modification Support" is required, the following procedure is initiated:

The MGW sends a NOT.req command with the following information to indicate that the bearer can be modified.

Table 14.2.39.1: NOT.req (Bearer Modification Support) MGW to MGC

| Address Information | Control information | Bearer information |
|---------------------|--|--------------------|
| | Transaction ID = z Context ID = c1 Termination ID = bearer1 Event_ID (Event ID = x, "Bearer modification possible") | |

When the processing of command (1) is complete, the MGW initiates the following procedure.

Table 14.2.39.2: NOT.resp (Bearer Modification Support) MGC to MGW

| Address Information | Control information | Bearer information |
|---------------------|---|--------------------|
| | Transaction ID = z Context ID = c1 Termination ID = bearer1 | |

14.2.40 CTM report

When the procedure "CTM report" is required the following procedure is initiated:

The MGW sends a NOT.req command with the following information.

Table 14.2.40.1: NOT.req (CTM report) MGW to MGC

| Address Information | Control information | Bearer information |
|---------------------|--|--------------------|
| | Transaction ID = z Context ID = c1 Termination ID = bearer1 Event_ID (Event ID = x, " connchnng ") | |

When the processing of command (1) is complete, the MGC initiates the following procedure.

Table 14.2.40.2: NOT.resp (CTM report) MGC to MGW

| Address Information | Control information | Bearer information |
|---------------------|---|--------------------|
| | Transaction ID = z Context ID = c1 Termination ID = bearer1 | |

14.2.41 Prepare IP transport

This procedure is activated when the "Prepare IP transport" procedure is initiated.

An ADD.req command is sent with the following information.

Table 14.2.41.1: ADD.req (Prepare IP transport) MGC to MGW

| Address Information | Control information | Bearer information |
|---|--|---|
| IP Transport Address=? UDP port =? | Transaction ID = z Termination ID = ? Logical Port ID = y If Context Requested: Context ID = ? If Context Provided: Context ID = c1 UP mode = mode UP version = version Delivery of erroneous SDUs = value Interface = interface If support mode: Initdirection = initdir State= ctmstate Transport= ctmtransport Version= ctmtext version If data call and Non-Anchor MGW RAN-side termination: Bitrate = bitrate (NOTE1) Notification_Requested (Event ID = x, "BNC Connected", "BNC Release (Cause)", "BNC Modified", "BNC Mod Failed") – as defined in ITU-T Recommendation Q.1950 [23] | If SCUDIF multimedia call and Anchor MGW Access Termination: MuMe codec (NOTE 2) If data call other than SCUDIF multimedia call, Anchor MGW Access Termination: PLMN bearer capability = PLMN capability (NOTE2) <u>If data call and Non-Anchor RAN termination:</u> Bearer Service Characteristics (NOTE 1) <u>If speech call, Access Termination:</u> Codec Bearer Characteristics = "IP" |
| NOTE1 : Bearer Service Characteristics shall be excluded when Bitrate is included except for the case when bitrate = 64000 and then Bearer Service Characteristics may be included. Bitrate is optional for transparent data calls when the data rate is 64k bits/s.. | | |
| NOTE2: Bearer Service Characteristics shall be excluded when this property is included. | | |

When the processing of command (1) is complete, the MGW initiates the following procedure.

Table 14.2.41.2: ADD.resp (Prepare IP transport) MGW to MGC

| Address Information | Control information | Bearer information |
|---|---|--------------------|
| IP-Transport Address=Ipaddress UDP port =UDPport | Transaction ID = z Context ID = c1 Termination ID = bearer1 | |

14.2.42 Modify IP transport address

This procedure is activated when the "Modify IP transport address" procedure is initiated.

A MOD.req command is sent with the following information.

Table 14.2.42.1: MOD.req (Modify IP transport address) MSC to MGW

| Address Information | Control information | Bearer information |
|--|---|--------------------|
| IP-Transport Address=Ipaddress UDP port =UDP port | Transaction ID = z Context ID = c1 Termination ID = bearer1 | |

When the processing of command (1) is complete, the MGW initiates the following procedure.

Table 14.2.42.2: MOD.resp (Modify Ip transport address) MGW to MGC

| Address Information | Control information | Bearer information |
|---------------------|--|--------------------|
| | Transaction ID = z Context ID = c1 TerminationID=bearer1 | |

14.2.43 Reserve Bearer Characteristics

This procedure is the same as that defined in the subclause "Reserve Char" in ITU-T Recommendation Q.1950 [23] (see 3GPP TS 29.205 [7]) with additions as shown below.

Table 14.2.43.1: Reserve Bearer Characteristics additions

| Address Information | Control information | Bearer information |
|---------------------|---|--------------------|
| | If framing protocol used: UP mode = mode UPversion =version Delivery of erroneous SDUs=value Interface=interface Initdirerection=initdirection | |

If the "Reserve Bearer Characteristics" procedure contains a codec that is not currently in use at the Termination when it receives this procedure, and if the framing protocol is used in support mode, the MGW shall be prepared to handle a framing protocol initialisation. If the "Reserve Bearer Characteristics" contains no codec or the codec that is already in use at the Termination when it receives this procedure, the MGW does not need to be prepared to handle a framing protocol initialisation.

14.2.44 Confirm Bearer Characteristics

This procedure is the same as that defined in the subclause "Confirm Char" in ITU-T Recommendation Q.1950 [23] (see 3GPP TS 29.205 [7]) with additions as shown below.

Table 14.2.44: Confirm Bearer Characteristics additions

| Address Information | Control information | Bearer information |
|---------------------|---|--------------------|
| | If framing protocol used: UP mode = mode UPversion =version Delivery of erroneous SDUs=value Interface=interface Initdirerection=initdirection | |

If the "Confirm Bearer Characteristics" procedure contains a codec that is not currently in use at the Termination when it receives this procedure, and if the framing protocol is used in support mode, the MGW shall be prepared to handle a framing protocol initialisation. If the "Confirm Bearer Characteristics" contains no codec or the codec that is already in use at the Termination when it receives this procedure, the MGW does not need to be prepared to handle a framing protocol initialisation.

14.2.45 Trace activation/deactivation

This procedure is activated when the "Trace activation/deactivation" procedure is initiated.

An ADD.req command is sent with the following information.

Table 14.2.45.1: ADD.req/MOD.req (Trace activation/deactivation) MGC to MGW

| Address Information | Control information | Bearer information |
|---------------------|--|--------------------|
| | Transaction ID = z Termination ID = bearer1 Context ID = c1 Trace Reference Trace Recording Session Reference Trace Depth Triggering events List of interfaces IMSI IMEI(SV) Trace activity control = trace activity request If indication on Trace Activation Result requested: NotificationRequested (Event ID = x, "Trace activation result") | |

Upon completion of processing command (1) an ADD.resp or MOD.resp command (2) is sent.

Table 14.2.45.2: ADD.resp/MOD.resp/ MGW to MGC

| Address Information | Control information | Bearer information |
|---------------------|--|--------------------|
| | Transaction ID = z Context ID = c1 TerminationID = bearer1 | |

14.2.46 Trace Activation result notification

When the procedure "Trace Activation result notification" is required, the following procedure is initiated:

The MGW sends a NOT.req command with the following information to indicate the result of the trace activation.

Table 14.2.46.1: NOT.req (Trace Activation result Notification) MGW to MGC

| Address Information | Control information | Bearer information |
|---------------------|--|--------------------|
| | Transaction ID = z Context ID = c1 Termination ID = bearer1 Event_ID (Event ID = x, "Trace activation result") | |

When the processing of command (1) is complete, the MGC initiates the following procedure.

Table 14.2.46.2: NOT.resp (Trace Activation result Notification) MGC to MGW

| Address Information | Control information | Bearer information |
|---------------------|---|--------------------|
| | Transaction ID = z Context ID = c1 Termination ID = bearer1 | |

14.2.47 Emergency Call Indication

This procedure is the same as that defined in the subclause " ECS_Indication " in ITU-T Recommendation Q.1950 Annex F [23] (see 3GPP TS 29.205 [7]) with additions as shown below.

Table 14.2.47.1: Emergency Call Indication additions

| Address Information | Control information | Bearer information |
|---|--|---|
| Or as per flow 14.2.4 Establish Bearer | Or as per flow 14.2.4 Establish Bearer With the following additions: If Context Requested & Emergency Call: Emergency Call Indication | Or as per flow 14.2.4 Establish Bearer |
| Or as per flow 14.2.5 Prepare Bearer | Or as per flow 14.2.5 Prepare Bearer With the following additions: If Context Requested & Emergency Call: Emergency Call Indication | Or as per flow 14.2.5 Prepare Bearer |
| Or as per flow 14.2.12 Play Announcement | Or as per flow 14.2.12 Play Announcement With the following additions: If Context Requested & Emergency Call: Emergency Call Indication | Or as per flow 14.2.12 Play Announcement |
| Or as per flow 14.2.18 Reserve_Circuit | Or as per flow 14.2.18 Reserve_Circuit With the following additions: If Context Requested & Emergency Call: Emergency Call Indication | Or as per flow 14.2.18 Reserve_Circuit |
| Or as per flow 14.2.41 Prepare_IP_transport | Or as per flow 14.2.41 Prepare_IP_transport With the following additions: If Context Requested & Emergency Call: Emergency Call Indication | Or as per flow 14.2.41 Prepare_IP_transport |
| Or as per flow 14.2.2 Isolate Bearer Termination | Or as per flow 14.2.2 Isolate Bearer Termination With the following additions: If Context Requested & Emergency Call: Emergency Call Indication | Or as per flow 14.2.2 Isolate Bearer Termination |
| Or as per flow 14.2.3 Join Bearer Termination | Or as per flow 14.2.3 Join Bearer Termination With the following additions: If Context Requested & Emergency Call: Emergency Call Indication | Or as per flow 14.2.3 Join Bearer Termination |

14.2.48 TFO status Notify

When the procedure "TFO status notify" is required the following procedure is initiated:

The MGC sends a ADD.req, MOD.req or MOV req. command with the following information.

Table 14.2.48.1: ADD.req/MOD.req/MOV.req (TFO status) MGC to MGW

| Address Information | Control information | Bearer information |
|---------------------|---|--------------------|
| | Transaction ID = z Context ID = c1 Termination ID = bearer1 NotificationRequested (Event ID = x, "TFO Status") | |

The support of the TFO status notification is optional in the TFO package. If supported, when the processing of command (1) is complete, the MGW initiates the following procedure.

Table 14.2.48.2: ADD.resp/MOD.resp/MOV.resp (TFO status) MGW to MGC

| Address Information | Control information | Bearer information |
|---------------------|---|--------------------|
| | Transaction ID = z Context ID = c1 TerminationID= bearer1 | |

Otherwise it returns an error codec to the MGC indicating that the requested event is unsupported or unknown., as specified in ITU-T Recommendation H.248.8 [14].

14.2.49 TFO Status

When the procedure "TFO Status" is required the following procedure is initiated:

The MGW sends a NOT.req command with the following information.

Table 14.2.49.1: NOT.req (TFO Status) MGW to MGC

| Address Information | Control information | Bearer information |
|---------------------|--|--------------------|
| | Transaction ID = z Context ID = c1 Termination ID = bearer1 Event_ID (Event ID = x, "TFO Status") | |

When the processing of command (1) is complete, the MGW initiates the following procedure.

Table 14.2.49.2: NOT.resp (TFO Status) MGC to MGW

| Address Information | Control information | Bearer information |
|---------------------|---|--------------------|
| | Transaction ID = z Context ID = c1 Termination ID = bearer1 | |

15 UMTS packages

15.1 Mandatory UMTS packages

The following package shall be supported for the UMTS Bearer Independent Circuit-Switched Core Network:

- 3GUP (User Plane) package (see subclause 15.1.1).

15.1.1 3GUP package.

PackageID: threegup (0x002f)
Version: 1
Extends: None

This package identifies that the User Plane package is used for the termination. It also contains some parameters for the User Plane functions in the MGW.

The UP Protocol operates independently of the stream mode property, i.e. type 14 UP PDUs (which are used for inband UP signalling) can be transported between UP peers, irrespective of the stream mode direction. However, other types of UP PDUs shall be handled according to the stream mode property.

15.1.1.1 Properties

UP Mode of operation:

PropertyID: mode (0x0001).

Description: Defines the mode of operation of the User Plane functions , for further definitions see 3GPP TS 25.415 [4] and 29.415 [8].

Type: Enumeration.

Possible Values:

- "Trans" (0x0001) Transparent mode.
- "Supp" (0x0002) Support mode for predefined SDU sizes.

Default: "Trans" (0x0001) Transparent mode.

Defined in: Local Control descriptor.

Characteristics: Read/Write.

UP versions:

PropertyID: upversions (0x0002).

Description: Defines the required versions of the UP mode of operation.

Type: Sub-list of enumeration.

Possible Values:

- "1" (0x01) Version 1.
- "2" (0x02) Version 2.
- "3" (0x03) Version 3.
- "4" (0x04) Version 4.
- "5" (0x05) Version 5.
- "6" (0x06) Version 6.
- "7" (0x07) Version 7.
- "8" (0x08) Version 8.
- "9" (0x09) Version 9.
- "10" (0x0A) Version 10.

- "11" (0x0B) Version 11.
- "12" (0x0C) Version 12.
- "13" (0x0D) Version 13.
- "14" (0x0E) Version 14.
- "15" (0x0F) Version 15.
- "16" (0x10) Version 16.
- Default: "1" (0x01) Version 1.

Defined in: Local Control descriptor.

Characteristics: Read/Write.

Delivery of erroneous SDUs:

PropertyID: delerrrsdu (0x0003).

Description: Indicates how erroneous SDUs should be handled. If it is set to YES then the UP entity implements error checking and sets Frame Quality Classification (FQC) bits accordingly; bad frames are delivered to the UP layer. If it is set to NO then the UP entity performs error checking and if a bad frame is detected then it is discarded. These settings are required only when the payload is to be examined by upper layer services; an MGW may ignore the settings of this parameter if it passes frames transparently through the UP entities. If it is set to NA then no checking is performed.

Type: Enumeration.

Possible Values:

- "Yes" (0x0001) Yes.
- "No" (0x0002) No.
- "NA" (0x0003) Not Applicable.

Default: "NA" (0x0003) Not Applicable.

Defined in: Local Control descriptor.

Characteristics: Read/Write.

Interface:

PropertyID: interface (0x0004).

Description: Indicates the type of interface on which the termination is used.

Type: Enumeration.

Possible Values:

- "RAN" (0x0001) Iu interface.
- "CN" (0x0002) Nb interface.

Defined in: Local Control descriptor.

Characteristics: Read/Write.

Initialisation Direction:

PropertyID: initdir (0x0005).

Description: Indicates whether or not the termination in the MGW should expect initialisation information, or initiate UP initialisation itself.

For a termination with property "interface = CN":

- If Initialisation Direction is set to Incoming then the MGW shall expect to receive an initialisation either at this termination or from an other Nb or Iu termination in the same context.
- If Initialisation Direction is set to outgoing, then the MGW shall send out an initialisation procedure from this termination. If another termination in the same context is initialised with the same codec type and configuration the MGW should re-use the RFCI values for its Initialisation PDU, otherwise it must assign its own values.

For a termination with property "interface = RAN":

- If Initialisation Direction is set to "incoming", then the initialisation received at this termination is from the originating RAN and can be forwarded internally to other terminations for subsequent UP initialisations.
- If Initialisation Direction is set to "outgoing", then initialisations received are from the terminating RAN and cannot be forwarded internally. RFCI value correction can be performed at this termination, and initialisations can be sent out to the RAN.

Examples for the usage of this property are given in annex B.

Type: Enumeration.

Possible Values:

- "In" (0x0001) Incoming.
- "Out" (0x0002) Outgoing.

Defined in: Local Control descriptor.

Characteristics: Read/Write.

15.1.1.2 Events

None.

15.1.1.3 Signals

None.

15.1.1.4 Statistics

None.

15.1.1.5 Procedures

The MGC uses this package to indicate to the MGW that the Iu (or Nb) User Plane is used between the RNC (or distant MGW) and the MGW. The package is sent in the Establish bearer, Modify Bearer Characteristics and Prepare bearer procedures. For more information on the User Plane and for a description of 'UP mode of operation', 'UP versions' and 'Delivery of erroneous SDUs' see 3GPP TS 25.415 [4].

The following procedures are valid for UP in Support Mode:

- The MGW shall be able to initiate and respond to the UP control procedures (PDU type 14 frames) independently of the Stream Mode during the call establishment phase, i.e. when not in TrFO.

- Otherwise, during TrFO the MGW shall be able to forward UP control procedures (PDU type 14 frames) received at one termination to the other termination.
- The UP Initialisation procedure is always acknowledged between MGW peers. If an MGW receives a request for a notification for the bearer establishment then the MGW shall not send the notification until after it has either sent or received the acknowledgement for the UP initialisation.
- The MGW shall always store RFCI parameters against the MGW termination that received or that sent the UP initialisation.
- If an MGW has the UP termination property Initialisation Direction = Incoming then it expects to either receive an Initialisation (externally) or after receiving initialisation information internally send an initialisation (externally), based on what occurs first.
- If an MGW has UP termination property Initialisation Direction = Outgoing and interface CN, then it generates a network originated Initialisation PDU as soon as the bearer towards the succeeding node is successfully established, with RFCIs corresponding to the last codec configured on the termination. If another termination in the same context is initialised with the same codec type and configuration the MGW should re-use the RFCI values for its Initialisation PDU, otherwise it must assign its own values. The initialisation information sent by the MGW depends on the service that the bearer supports. For CSD service see 3GPP TS 29.007 [6] chapter 11.5. For speech service see 3GPP TS 26.102 [26] chapter 8.
- If an MGW has UP termination property Initialisation Direction = Outgoing and interface RAN, then it expects to receive an Initialisation externally. It shall not pass the initialisation parameters internally. It may initiate RFCI Value Correction out from this termination.
- A CN incoming or outgoing termination having already completed its UP initialisation towards a peer MGW shall not send externally any new UP initialisation except if a reserve / modify characteristic procedure occurred on that termination since the last initialisation.
- RAN Outgoing termination may perform, during its lifetime, subsequent RFCI Value corrections, e.g. due to changes of RFCIs on other terminations.
- If an MGW has two terminations in the same context defined as supporting the UP package and with Initialisation Direction incoming, then when it receives an Initialisation procedure from one side (provided the bearer connection from the other termination to its peer MGW is established) it shall start the UP initialisation procedure towards the peer MGW. The MGW shall perform this procedure independently of the through-connection of the terminations in the context. The MGW shall relay control information from the first initialisation to the UP peer for use at the subsequent initialisation. Also, subsequent control procedures received on one UP shall be relayed to the other UP entity when the two UP entities are connected within the MGW. This behaviour is described in more detail in Annex A. - When adding a new CN incoming termination to a context that has already a RAN or CN incoming termination, if the existing termination has already completed its UP initialisation, the MGW shall not start an initialisation procedure on the new termination based on the control information already stored at the initialised incoming termination in the context.
- If an MGW has one termination with properties "interface = RAN" and "initialisation direction = outgoing" and another termination with property "initialisation direction = Incoming" in the same context, then the MGW shall not forward the UP initialisation from the Incoming termination until it has received a UP initialisation at the "RAN"/"outgoing" side. If the codec type and codec modes configured on both terminations are identical, and if the RFCI values stored at the "incoming" termination do not match the RFCI values stored at the "outgoing" RAN side then "RFCI Value Correction" may be performed to the "outgoing" RAN side: The MGW starts UP initialisation with the RFCI values 'relayed' from the "Incoming" side. No "RFCI Value Correction" is permitted at an outgoing RAN termination whose Iu initialisation negotiates the version 1 of the support mode, at an "incoming" Iu termination or at any Nb termination.
- If a new RAN outgoing termination is added to a context that has already a RAN incoming or CN incoming termination, and if the existing termination has already completed its UP initialisation, the MGW may carry out a RFCI value correction on the new RAN outgoing termination., The control information to be used for the RFCI value correction shall be relayed from the initialised incoming termination in the context.
- No RFCI value correction shall be triggered for data call.
- As an implementation option, "RFCI Value Correction" may be delayed if terminations are not through-connected; it will be triggered by connection modification. Otherwise it shall be performed immediately

- If "RFCI Value Correction" is not performed the MGW shall map the indexes for frames from one side to the RFCI indexes for frames from the other side. This behaviour is described in more detail in Annex A.
- If an MGW has two RAN terminations connected to the same context then the "RFCI Value Correction" is performed by the Outgoing termination.
- If an MGW has two terminations which support the UP package connected to the same context and both RFCI sets match then the MGW may pass frames transparently through the UP entities; no monitoring of the frames is performed, provided that the terminations are through-connected. This behaviour is described further in Annex A.
- If the MGW is passing frames transparently, no UP monitoring is performed. When the MGW receives an H.248 procedure request which requires interpretation or interaction with the UP, then it shall resume its UP protocol responsibilities, i.e. perform monitoring or termination of the UP protocol.
- If an MGW sends an FP UP initialization message from a termination, the MGW shall only offer versions of the FP UP, which are given in the property "UP versions" of this termination and which are supported by the MGW for this termination.
- If an MGW receives an FP UP initialization message at a termination, the MGW shall only positively acknowledge this initialization message, if versions of the FP UP are offered, which are given in the property "UP versions" and which are supported at the MGW for this termination. In the positive FP UP initialization acknowledge message, the MGW shall select one of these versions. If none of these versions are offered in the FP UP initialization message, the MGW shall send a negative FP UP acknowledge message and it shall not forward the initialization to a possible second FP UP termination in the same context.
- If PCM is used on the Nb then FP UP initialization shall be performed by the termination with property "Outgoing". If the termination property is "Incoming" then it shall receive the RFCI's from its IuFP peer (or from internal MGW termination with IuFP and same codec). If IuFP is defined on another termination in the MGW but the codec is different, i.e. not TrFO then the relaying of RFCI's shall not be performed. These IuFP peer connection shall be seen as completely separate.
- the UP initialisation information attached to a termination (RFCI values, codec type and mode(s), UP initialisation completed or not) are kept unchanged when the termination is moved to a new context.
- the initialisation direction may be changed during the lifetime of a termination ; upon such a change, the MGW shall apply the behaviour attached to the new initialisation direction.

The procedures for a termination configured in UP Transparent Mode are those described in 3GPP TS 25.415 [4].

15.1.2 Void

15.1.3 Void

15.1.4 Void

15.1.5 Void

15.1.6 Void

15.1.7 Void

15.1.8 Void

15.1.9 Void

15.2 Optional UMTS packages

The following packages may be supported by the UMTS Bearer Independent Circuit-Switched Core Network as required by the network services deployed in the network:

- Circuit Switched Data package (see subclause 15.2.1);
- TFO package (see subclause 15.2.2);
- 3G Expanded Call Progress Tones Generator package (see subclause 15.2.3);
- Modification of Link Characteristics Bearer Capability package (see subclause 15.2.4);
- Enhanced Circuit Switched Data package (see subclause 15.2.5);
- Cellular Text telephone Modem Text Transport package (see subclause 15.2.6);
- IP transport package (see subclause 15.2.7);
- Flexible Tone Generator Package (see subclause 15.2.8);
- Trace Package (see subclause 15.2.9).

15.2.1 Circuit Switched Data package

PackageID: threegcsd (0x0030)

Version: 1

Extends: None

This package contains the information needed to be able to support GSM and UMTS Circuit Switched Data from the media gateway.

15.2.1.1 Properties

PLMN BC:

PropertyID: plmnbc (0x0001).

Description: The PLMN Bearer Capability.

Type: Octet string.

Possible values:

- Specified in the subclause "Bearer capability" in 3GPP TS 24.008 [3], including the Bearer Capability IEI and Length.

Defined in: Local Control Descriptor.

Characteristics: Read/Write.

GSM channel coding:

PropertyID: gsmchancod (0x0002).

Description: Channel information needed for GSM.

Type: Octet string.

Possible values:

- The second octet of Chosen Channel as specified in the subclause "Chosen Channel" in 3GPP TS 48.008 [9].

Defined in: Local Control Descriptor.

Characteristics: Read/Write.

15.2.1.2 Events

Protocol Negotiation Result:

EventID: protres (0x0001).

Description: This event is used to report the result of the protocol negotiation.

EventsDescriptor Parameters: None.

ObservedEventsDescriptor Parameters:

- Negotiation Result:
 - ParameterId: result (0x0001).
 - Description: reports whether the protocol negotiation has been successful.
 - Type: Enumeration.
 - Possible Values:
 - "Success" (0x0001): the protocol negotiation on the termination has been successful.
 - "Failure" (0x0000): the protocol negotiation on the termination has failed.
- Possible Failure Cause:
 - ParameterId: cause (0x0002).
 - Description: indicates the possible failure cause.
 - Type: Enumeration.
 - Possible Values:
 - "Unsp" (0x0001): the protocol negotiation has failed for an unspecified reason.
 - "V8V34" (0x0002): the V.8 or the V.34 protocol negotiation has failed (modem termination only).

Rate Change:

EventID: ratechg (0x0002).

Description: This event is used to report a rate change. For example for GSM FAX if the detected rate does not match the channel rate the MGW shall use this to request a new channel rate. See CMM in 3GPP TS 43.045 [35].

EventsDescriptor Parameters: None.

ObservedEventsDescriptor Parameters:

- New Rate:
 - ParameterId: rate (0x0001).
 - Description: reports the new rate for the termination.
 - Type: Integer.
 - Possible Values: transmission rate in bits per second, rounded to the nearest integer value. The value must be a valid bitrate; one of the following rates: 2400, 4800, 9600, 14400, 28800, 57600. An invalid rate shall cause the call to be released by the MSC Server.

15.2.1.3 Signals

Activate Protocol:

SignalID: actprot (0x0001).

Description: Activate the higher layer protocol.

Signal type: Brief.

Duration: N/A.

Additional parameter:

- Local Peer Role:
 - ParameterID: localpeer (0x0001).
 - Type: Enumeration.
 - Possible values:
 - "Orig" (0x0000): originating.
 - "Term" (0x0001): terminating.
 - Description: This parameter is optional, but is required for modem and fax calls. It is used to inform the modem whether it should act as originating or terminating peer. This parameter is only included within signal towards the radio access. This may either be a Access Termination or a CN Termination toward another MGW that serves the radio access..

15.2.1.4 Statistics

None.

15.2.1.5 Procedures

This package is used to set up data calls within the CS domain. For more information on the IWF, refer to 3GPP TS 29.007 [6].

When the Media Gateway Controller initiates the "Establish Bearer" procedure, the "Prepare Bearer" procedure, the "Modify Bearer" procedure or the "Reserve Circuit" procedure, it shall provide the PLMN BC ("plmnc" property above) for the termination on the mobile side and the ISDN BC (standard H.248 properties, subclause "Bearer

Capabilities") for the termination on the fixed side. For a mobile-to-mobile call, it shall provide the PLMN BC on both terminations.

The presence of the PLMN BC property may trigger the use of the IWF.

Once the bearer has been established, after B-answer, the "Activate Interworking Function" procedure is used to activate the IWF. The Activate Protocol signal ("actprot") will start the negotiation of the layer 2 protocols on both sides. If a modem or fax service is requested, the signal shall contain the Local Peer Role parameter ("localpeer"), to tell the modem whether it should act as originating or terminating peer.

NOTE: The Activate Protocol signal is needed only after B-answer as described above or after successful in-call modification from speech to fax, to activate the protocol timers at the correct time. This is the only time when this signal is needed (specifically, the signal is not used after a handover sequence or for lawful interception).

The IWF Protocol Indication notifications are used by the MGW to inform the MSC server about IWF protocol events. The MSC has to request the detection of the events "Protocol Negotiation Result" and "Rate Change" in the "Activate IWF" procedure, the "Establish Bearer" procedure, the "Prepare Bearer" procedure, the "Modify Bearer" procedure or the "Reserve Circuit" procedure.

For handover to GSM, or change of channel characteristics within the GSM network, the property GSM Channel Coding ("gsmchancod"), which contains the information about the channel type and the number of channels, shall be transmitted to the termination on the mobile side in the "Establish Bearer", the "Prepare Bearer" and the "Reserve Circuit" procedures together with the PLMN BC. The presence of the GSM Channel Coding property also indicates that the termination is using a GSM access network.

If the MGW has requested a rate change due to GSM fax rate mismatch (CMM procedure see 3GPP TS 43.045 [35]) then it shall suspend transmission until it the MSC Server has modified the PLMN Bearer Capability and GSM Channel Coding property to match the required rate. If this occurs while other context manipulations are occurring the MGW shall only resume transmission when the streams are bothway connected and the PLMN Bearer Capability and Channel Coding are correct. The MGW shall not send subsequent rate change notifications while the outstanding rate change has not been performed by the MSC Server.

15.2.2 TFO package

PackageID: threegtfo (0x0031)
Version: 2
Extends: None

This package defines events and properties for Tandem Free Operation (TFO) control. TFO uses inband signalling and procedures for Transcoders to enable compressed speech to be maintained between a tandem pair of transcoders. This package allows an MGW, which has inserted a transcoder, to support TFO.

15.2.2.1 Properties

TFO Activity Control:

PropertyID: tfoenable (0x0001).

Description: Defines if TFO is enabled or not.

Type: Enumeration.

Possible Values:

- "On" (0x0001): TFO is enabled, TFO protocol is supported.
- "Off" (0x0002): TFO is not enabled, TFO protocol is not initiated or terminated.

Defined in: Local Control descriptor.

Characteristics: Read/Write.

TFO Codec List:

PropertyID: codeclist (0x0002).

Description: List of codecs for use in TFO protocol, the Local Used Codec (see 3GPP TS 28.062 [5]) is always the first entry in the list. The MSC Server may enable TFO without providing a TFO Codec List ; in this case, the MGW shall behave as if it had received a TFO Codec List composed of the selected codec of the opposing termination within the Context.

Type: Sub-list of Octet string.

Possible Values:

- List of codec types; each entry:

Mc Single Codec, similar to as defined in ITU-T Recommendation Q.765.5 [24], for single codec information (figure 14/Q.765.5), where the Codec Information is defined either in ITU-T Recommendation Q.765.5 [24] or in another specification for the given Organization Identifier. For 3GPP codecs these are defined in 3GPP TS 26.103 [16]. The ACodec property in H.248 binary encoding or codeconfig attribute in H.248 text encoding contain the contents of the ITU-T Single Codec IE, excluding the Single Codec Identifier, Length Indication and Compatibility Information.

In H.248 text encoding, the value of the codeclist property shall be encoded as:

LBRKT codeconfig *(COMMA codeconfig) RBRKT

Example: H.248 text encoding of the TFO codec list (UMTS_AMR_2 with Preferred Configuration set 1, and UMTS_AMR-WB with Preferred Configuration set 0):

Threegtfo/codeclist = { 0206959504 , 020A00 }

Where:

- UMTS_AMR_2 parameters are: ETSI, UMTS_AMR_2, ACS={12.2, 7.4, 5.9, 4.75}, SCS={12.2, 7.4, 5.9, 4.75}, OM=0 plus MACS=4
- UMTS_AMR_WB parameters are: ETSI, UMTS_AMR_WB, Config-WB-Code=00

Defined in: Local Control descriptor.

Characteristics: Read/Write.

15.2.2.2 Events

Optimal Codec Event:

EventID: codec_modify (0x0010).

Description: The event is used to notify the MGC that TFO negotiation has resulted in an optimal codec type being proposed.

EventsDescriptor Parameters: None.

ObservedEventsDescriptor Parameters:

- Optimal Codec Type.
 - ParameterID: optimalcodec (0x0011).
 - Description: indicates which is the proposed codec type for TFO.
 - Type: Octet string.

- Possible Values:

Mc Single Codec;

Similar to as defined in ITU-T Recommendation Q.765.5 [24], for single codec information (figure 14/Q.765.5), where the Codec Information is defined either in ITU-T Recommendation Q.765.5 [24] or in another specification for the given Organization Identifier. For 3GPP codecs these are defined in 3GPP TS 26.103 [16]. The ACodec property in H.248 binary encoding or codeconfig attribute in H.248 text encoding contain the contents of the ITU-T Single Codec IE, excluding the Single Codec Identifier, Length Indication and Compatibility Information.

Codec List Event:

EventID: distant_codec_list (0x0012).

Description: The event is used to notify the MGC of the distant TFO partner's supported codec list.

EventsDescriptor Parameters: None.

ObservedEventsDescriptor Parameters:

- Distant Codec List:
 - ParameterID: distlist(0x0013).
 - Description: indicates the codec list for TFO.
 - Type: Sub-list of Octet string.
 - Possible Values:

List of codec types; each entry:

Mc Single Codec similar to as defined in ITU-T Recommendation Q.765.5 [24], for single codec information (figure 14/Q.765.5), where the Codec Information is defined either in ITU-T Recommendation Q.765.5 [24] or in another specification for the given Organization Identifier. For 3GPP codecs these are defined in 3GPP TS 26.103 [16]. The ACodec property in H.248 binary encoding or codeconfig attribute in H.248 text encoding contain the contents of the ITU-T Single Codec IE, excluding the Single Codec Identifier, Length Indication and Compatibility Information.

The first Codec Type in the list is the Distant Used Codec, received from the distant TFO partner (see 3GPP TS 28.062 [5]). .

In H.248 text encoding, the value of the distlist parameter shall be encoded as:

LBRKT codeconfig *(COMMA codeconfig) RBRKT

TFO Status Event:

EventID: TFO_status (0x0014).

Description: The event is used to notify the MGC that a TFO link has been established or broken.

EventsDescriptor Parameters: None.

ObservedEventsDescriptor Parameters:

- TFO Status:
 - ParameterId: tfostatus (0x0015).
 - Description: reports whether TFO has been established or broken. Upon TFO activation, no notification is sent if TFO has not been established. A TFO_Off notification is only reported when a TFO link previously established is broken. The MGW should not report transient TFO status change.
 - Type: Boolean

- Possible Values:
 - "TFO_On" : TFO has been established.
 - "TFO_Off" : TFO is no more established.

15.2.2.3 Signals

None.

15.2.2.4 Statistics

None.

15.2.2.5 Procedures

For the procedures for TFO see 3GPP TS 28.062 [5].

To enable TFO, the MSC Server shall configure the properties of this package on a MGW Termination with the media stream property for Codec Type set to ITU-T Recommendation G.711 [25] (see annex C of ITU-T Recommendation H.248 [10]) or Bearer Service Characteristics set to "Speech" or "3.1 kHz Audio" in TMR or USI due to Reserve Circuit Procedure, see in ITU-T Recommendation Q.1950 (see 3GPP TS 29.205 [7]).

The TFO protocol shall be disabled if the call configuration becomes no longer TFO compatible or if the Codec Type property of the media stream at the opposing termination in the Context is reconfigured to G.711 or if the Bearer Service Characteristics of the opposing Termination is reconfigured to "Speech" or "3.1 kHz Audio". The TFO protocol may be disabled either by the MSC Server by using the TFO Activity Control property of this package or by the MGW in accordance with the TFO rules as described in [5] when it detects that TFO operation is no longer possible (for example it has G.711 encoding at opposing Terminations).

15.2.3 3G Expanded Call Progress Tones Generator Package

PackageID: threexcg(0x0032)

Version: 1

Extends: xcg version1

This package extends "Expanded Call Progress Tones Generator Package", as defined in ITU-T Recommendation Q.1950 [23] (see 3GPP TS 29.205 [7]). The package adds a new toneId for CAMEL prepaid warning tone.

15.2.3.1 Properties

None.

15.2.3.2 Events

None.

15.2.3.3 Signals

CAMEL Prepaid Warning Tone:

SignalID: cpwt (0x004f).

Description: Generate CAMEL prepaid warning tone to inform the party that the Max Call Period Duration is about to expire. CAMEL prepaid warning tone is defined in 3GPP TS 23.078 [22]. The physical characteristic of CAMEL prepaid warning tone is available in the gateway.

Signal type: Brief.

Duration: Provisioned, Not Auditable.

Additional parameters:

- Tone Direction.
- ParameterID: td (0x0010).
- Type: Enumeration.
- Values:
 - "Ext" (0x01): external.
 - "Int" (0x02): internal.
 - "Both" (0x03): Both.
- Default: "Ext".

15.2.3.4 Statistics

None.

15.2.3.5 Procedures

None.

15.2.4 Modification Of Link Characteristics Bearer Capability

PackageName: Modification of Link Characteristics Bearer Capability

PackageID: threegmlc(0x0046)

Description: This package contains an event that when requested by the MGC will cause the MG to notify the MGC that modification of the link characteristics is allowed. This notification is typically generated when the bearer has been established.

Version: 1

Extends: None

15.2.4.1 Properties

None.

15.2.4.2 Events

Bearer Modification Support Event.

EventID: mod_link_supp (0x0001).

Description: The event is used to notify the MGC that modification of the link characteristics of the current bearer connection is permitted.

EventsDescriptor Parameters: None.

ObservedEventsDescriptor Parameters: None.

15.2.4.3 Signals

None.

15.2.4.4 Statistics

None.

15.2.4.5 Procedures

If the MGC is interested in determining whether or not the bearer associated with a termination supports modification of its link characteristics it shall send a request (Add/Modify/Move) with the Bearer Modification Support Event. When the bearer is established the MG will indicate in a Notify request to the MGC if modification of link characteristics is supported. A notify will NOT be generated if modification is NOT supported on the bearer.

15.2.5 Enhanced Circuit Switched Data package

PackageID: threegcsden (0x0082)

Version: 1

Extends: threegcsd (0x030) Version 1

This package extends "Circuit Switched Data Package", as defined in subclause 15.1.2. This package adds a new property to define the user bitrate at a Iu termination.

15.2.5.1 Properties

Bitrate

PropertyID: bitrate (0x0003).

Description: user bitrate.

Type: Integer.

Possible Values: transmission rate in bits per second, rounded to the nearest integer value. The value shall be a valid bitrate; one of the following rates: 2400, 4800, 9600, 14400, 28800, 57600, 64000.

Defined in: Local Control Descriptor.

Characteristics: Read/Write.

15.2.5.2 Events

None.

15.2.5.3 Signals

None.

15.2.5.4 Statistics

None.

15.2.5.5 Procedures

This package is used in addition to the 3GCSD package for CS data calls. It is used for indicating the user data rates for Inter-MSR SRNS Relocation and handover cases. If the Bitrate is not 64 kb/s at one termination in the MGW but its opposing termination has properties that define its bitrate to be 64 kb/s (e.g. TMR=UDI) then A-TRAU' protocol shall be applied by the MGW. For further details see 3GPP TS 29.007 [6].

15.2.6 Cellular Text telephone Modem Text Transport

PackageName: CTM Text Transport

PackageID: threegctm (0x0068)

Description: The CTM text transport package is intended for enabling robust real time text conversation through a voice channel primarily intended for communication over mobile networks. This package includes the mechanisms needed to transport T.140 text conversation streams [19] in a voice channel environment, using the CTM Cellular Text Telephone Modem specified in 3GPP TS 26.226 [18]. The transport mechanism allows for alternating transport of voice and text.

Version: 1

Extends: None

15.2.6.1 Properties

Text termination connection state:

PropertyID: connstate (0x0001).

Description: The connection state property is used to reflect details of the achieved text connection. For each new session connstate should be reset to "Prepare".

Type: Enumeration.

Possible values:

- "Idle" (0x0001) meaning that CTM availability negotiation has failed; CTM is disabled except for monitoring the incoming line for CTM signals.
- "Prepare" (0x0002) for CTM being enabled, monitoring for CTM signals and ready to send CTM signals.
- "Connected" (0x0006) for CTM being enabled and to have detected CTM availability in the current session.

Defined in: TerminationState.

Characteristics: Read/Write.

Text Transport:

PropertyID: trpt (0x0002)

Description: The transport parameter reflects the transport mechanism selected for the Text Conversation termination. In 3GPP, one possible transport mechanism is the Cellular Text Telephone Modem as in 3GPP TS 26.226 [18]. It is used when it is desired to transport the text conversation in a voice channel. CTM enables alternating use of the voice channel for voice and text during the call.

Type: Enumeration.

Possible values:

- "ctm" (0x0008) for text transport in mobile voice channel as in 3GPP TS 26.226 [18].

Defined in: LocalControl.

Characteristics: Read/Write.

Text Protocol Version:

PropertyID: textproto (0x0003).

Description: The version of the ITU-T Recommendation T.140 [19] protocol used in the connection.

Type: Integer.

Possible values:

- Any integer corresponding to a T.140 version number (currently 1) as in ITU-T Recommendation H.248 .2 [17].

Defined in: LocalControl.

Characteristics: Read/Write.

15.2.6.2 Events

Connection State Change:

EventID: connchange (0x0001).

Description:

- This event will occur when the text connection state for the termination has changed.
- The parameter values are the same as the Connection State property.
- If a CTM availability request timed out, the state is returned to Idle.

EventDescriptorParameters:

None.

ObservedEventDescriptorParameters:

ParameterName: Connection Change.

ParameterID: connchng (0x0001).

Type: Enumeration.

Possible Values: As property threegctm/connstate.

15.2.6.3 Signals

None.

15.2.6.4 Statistics

Characters Transferred:

StatisticsID: chartrans (0x0001).

Description: Number of bytes of ITU-T Recommendation T.140 [19] data transferred through the termination.

Units: count.

15.2.6.5 Procedures

If the MGC detects a CTM indication it shall send a request (Add/Modify/Move) with the CTM Transport property. Upon receipt of it, the MGW shall allocate a termination with CTM capabilities. Normal usage is that the CTM enabled termination handles one text stream and one voice stream and alternates between transporting voice and text in the voice channel according to the functionality of CTM. This termination could for example be combined in a context with a termination with the txp and ctyp packages for gateway functionality between PSTN text telephony and mobile CTM based text telephony. These packages are described in ITU-T Recommendation H.248.2 [17].

The CTM algorithm has states. The states defined in the text termination connection state property are mapped into CTM states in the following way:

- Idle: CTM disabled because of an unsuccessful CTM availability negotiation.
- Prepare: normal initial state with CTM monitoring active.
- Connected: CTM negotiation is completed.

For each new call, the CTM termination shall be put in the Prepare state.

When the CTM availability negotiation is completed, the state is Connected.

The state transitions are automatic, except for setting Prepare state as described above.

15.2.7 IP transport package

PackageID: threegiptra (0x0083)

Version: 1

Extends: None

This package contains the information needed to be able to support IP transport from RAN to the media gateway.

15.2.7.1 Properties

IP transport address:

PropertyID: ipv4trans (0x0001).

Description: IP V4 transport address.

Type: Octet String.

Possible values:

- Specified as Transport Layer Address in 3GPP TS 25.413 [20].

Defined in: Local Control Descriptor.

Characteristics: Read/Write.

PropertyID: ipv6trans (0x0002).

Description: IP V6 transport address.

Type: Octet String .

Possible values:

- Specified as Transport Layer Address in 3GPP TS 25.413 [20].

Defined in: Local Control Descriptor.

Characteristics: Read/Write.

UDP port:

PropertyID: UDport (0x0003).

Description: UDP port.

Type: Unsigned integer.

Possible values: 0...65535.

- Specified as Iu transport Association in 3GPP TS 25.413 [20].

Defined in: Local Control Descriptor.

Characteristics: Read/Write.

15.2.7.2 Events

None.

15.2.7.3 Signals

None.

15.2.7.4 Statistics

None3

15.2.7.5 Procedures

When the MSC Server knows that it shall apply the set up procedure in accordance with 3GPP TS 25.414 [21], this package is used to set up an IP transport between the RAN and the CN.

When the Media Gateway Controller initiates the "prepare IP bearer transport" procedure towards the RAN side, it shall request the IP transport address and the UDP port from the MGW. The MGW shall provide the MSC Server with the IP transport address of the MGW and an UDP Port. At the receipt of these information elements the MSC Server shall insert the information elements in the RAB Assignment/ Relocation message.

When the MSC Server receives the RAB assignment acknowledge or Iu relocation request response, (which includes the IP transport address of the RNC and the UDP port) and the User Plane mode is Transparent, it shall initiate the Modify IP transport address procedure towards the MGW before the first data packet is to be sent from the MGW.

The MGW shall use the IP address and UDP port if received from the MSC Server to route the user data to the RNC regardless if IP addresses and UDP ports were previously exchanged in the User Plane.

15.2.8 Flexible Tone Generator Package

PackageID: threegflex (0x0084)

Version: 1

Extends: threegxcg version 1

This package extends "3G Expanded Call Progress Tones Generator Package", as defined in chapter 15.1.4 above. This package adds a new tone for call duration control in CAMEL phase 4, supporting variable sequence of tones and burst list.

15.2.8.1 Properties

None.

15.2.8.2 Events

None.

15.2.8.3 Signals

Signal Name: Flexible Tone.

SignalID: ft (0x0050).

Description: Generate flexible 900 Hz tone. The physical characteristics of Flexible Tone is not described in the additional parameters. It shall be available in the Media Gateway.

SignalType: Brief.

Duration: Provisioned.

Additional Parameters:

- Parameter Name: Burst List Direction

Description: Used to indicate the direction the tone is to be sent. External indicates that the tone is sent from the MG to an external point. Internal indicates that the tone is played into the Context to the other terminations. Both way indicates both internal and external behaviour.

ParameterID: bld (0x0001).

Type: Enumeration.

Possible Values:

- "Ext" (0x01): External.
- "Int" (0x02): Internal.
- "Both" (0x03): Both way.
- Default: "Ext" (0x01).

Parameter Name: numberOfBursts.

Description: Number of bursts in the burst list.

ParameterID: nob (0x0002).

Type: Integer.

Possible values: 1 to 3.

Default: 1.

Parameter Name: burstInterval.

Description: Time interval between two consecutive bursts expressed in amount of 100 ms units.

ParameterID: bi (0x0003).

Type: Integer.

Possible values: 1 to 1200.

Default: 2.

Parameter Name: numberOfTonesInBurst.

Description: Number of tones to be played in each burst.

ParameterID: notib (0x0004).

Type: Integer.

Possible values: 1 to 3.

Default: 3.

Parameter Name: toneDuration.

Description: Duration of each tone in a burst expressed in amount of 100 ms units.

ParameterID: td (0x0005).

Type: Integer.

Possible values: 1 to 20.

Default: 2.

Parameter Name: toneInterval.

Description: Time interval between two consecutive tones in a burst expressed in amount of 100 ms units.

ParameterID: ti (0x0006).

Type: Integer.

Possible values: 1 to 20.

Default: 2.

15.2.8.4 Statistics

None.

15.2.8.5 Procedures

The MGW should generate the tones using the above mentioned parameters as specified in 3GPP TS 23.078 [22] subclause 4.5.7.1.2

In case MGC requests to generate a flexible tone specifying a signal type "Timeout" and a "Duration" longer than the time needed to play the whole Burst List no action will be taken on the incoming stream to fill the gap. I.e. if any user plane stream is received on one side of the termination after the end of the burst list, it will be present, unchanged, on the other side of the termination as well (transparent mode).

15.2.9 Trace Package

PackageID: calltrace (0x0097)

Version: 1

Extends: None

This package defines properties for subscriber and equipment trace activation and deactivation properties to be attached to the trace record generated by MGW.

15.2.9.1 Properties

Trace Activation Control

PropertyID: traceactivityrequest(0x0001)

Description: Defines if trace is activated or deactivated.

Type: Bool

Possible Values:

"on" (true): Trace Session is activated in MGW

"off" (false): Trace Session is deactivated in MGW

Defined in: Local Control descriptor

Characteristics: Read/Write

IMSI

PropertyID: imsi(0x0002)

Description: IMSI number of the traced subscriber to be attached to the trace record. Used for record identification like trace reference.

Type: Octet string

Possible Values: The IMSI is coded as defined in 3GPP TS 23.003.

Defined in: Local Control descriptor

Characteristics: Read/Write

IMEI(SV)

PropertyID: imei_sv(0x0003)

Description: IMEI(SV) number of the traced equipment to be attached to the trace record. Used for record identification like trace reference.

Type: Octet string

Possible Values: The IMEI(SV) is coded as defined in 3GPP TS 23.003.

Defined in: Local Control descriptor

Characteristics: Read/Write

Trace Reference

PropertyID: tracereference(0x0004)

Description: Reference number to identify different Trace Session in OSS as defined in 3GPP TS 32.421 [29] and 3GPP TS 32.422 [30].

Type: Octet string

Possible Values: OSS (EM) defines when activating a Trace Session

Defined in: Local Control descriptor

Characteristics: Read/Write

Trace Recording Session Reference

PropertyID: tracerecsessionref(0x0005)

Description: A unique identifier within the Trace Session for identifying the Trace Recording sessions. Defined in 3GPP TS 32.421 [29] and in 3GPP TS 32.422 [30].

Type: Octet string

Possible Values: Described in 3GPP 32.422 [30]

Defined in: Local Control descriptor

Characteristics: Read/Write

Trace Depth

PropertyID: tracedepth(0x0006)

Description: Trace Depth as defined in 3GPP TS 32.421 [29]

Type: Enumeration

Possible Values: Defined in 3GPP TS 32.422 [30]

Defined in: Local Control descriptor

Characteristics: Read/Write

Triggerring Events

PropertyID: triggeringevent(0x0007)

Description: Triggerring Events as defined in 3GPP TS 32.422 [30].

Type: Octet string

Possible Values: Defined in 3GPP TS 32.422 [30].

Defined in: Local Control descriptor

Characteristics: Read/Write

List of interfaces

PropertyID: listofinterfaces(0x0008)

Description: List of interfaces to trace as defined in 3GPP TS 32.422 [30]

Type: Octet string

Possible Values: Defined in 3GPP TS 32.422 [30]

Defined in: Local Control descriptor

Characteristics: Read/Write

15.2.9.2 Events

Trace result

EventID: tracact (0x0001)

Description: Notification to the MSC Server if trace activation was successful/unsuccessful in the MGW.

EventDescriptor parameters: None

ObservedEventsDescriptor parameters:

Result: Trace Activation Result

res (0x0001)

Type: enumeration

Possible values:

success (0x0001): "Trace Successfully activated"

failure (0x0000): "Failure in trace activation"

15.2.9.3 Signals

None

15.2.9.4 Statistics

None

15.2.9.5 Procedures

For the network level procedures of the tracing see 3GPP 32.422 [30].

For the trace records of the MGW see 3GPP 32.423 [31].

In H.248 interface MSC Server uses 'Trace Activity Control' property to indicate MGW that a termination should be placed under trace or should be taken out of trace. In the call establishing phase MSC Server sets trace package information into proper command (Add or Modify) associated to the termination to be traced. Tracing can be activated either by giving IMEI(SV) or IMSI number as a further information. MSC Server shall also provide the values for all other properties described in this package that is IMSI if trace is activated based on IMSI, IMEI(SV) if trace is activated

based on IMEI(SV), Trace reference, Trace recording session reference, Trace depth, triggering events in MGW, list of interfaces in MGW. When MSC Server activates the trace, it shall use 'Trace Activation Result' Event to detect if the Trace Activation was successful or not. MGW shall not reject the Add/Modify because of unsuccessful Trace Activation, but only send a Notification with this Event. Tracing is automatically deactivated in MGW when termination is taken out of the context in the end of the call. If the Termination is Moved to another Context, trace is automatically forwarded to new termination.

Annex A (informative): The Framing protocol Interworking Function (FPIF)

A.1 Introduction

SDUs transmitted over an Iu or Nb interface and received at a MGW whose outgoing UP is also Iu or Nb shall be relayed to the outgoing UP MGW termination. If no interworking function (other than the FPIF) or transcoder device is inserted by the MGW, and if UP terminations are present, then PDUs and control procedures are passed between MGW terminations by the FPIF. The FPIF is the functional entity responsible for aligning or mapping control procedures (including RFCIs, frame numbers etc) on the separate UP interfaces according to the package procedures described in the main text. The FPIF determines if the two UP configurations are identical and thus the UP PDUs may be passed transparently. If the FPIF determines that the two UP configurations are not identical it applies the required mapping. The relaying of PDUs transparently can also be considered as FPIF bypass.

NOTE: the implementation in the MGW can perform a more efficient processing of the PDUs in this case. The MGW switching and bypassing of the protocol functions during TrFO is left to the manufacturer's implementation.

UP initialisations are not handled by the FPIF, only receipt of the Subflow combinations and the RFCI allocations are received by the FPIF for each UP.

The RFCIs are relayed by the FPIF as described in main text for the UP package procedures.

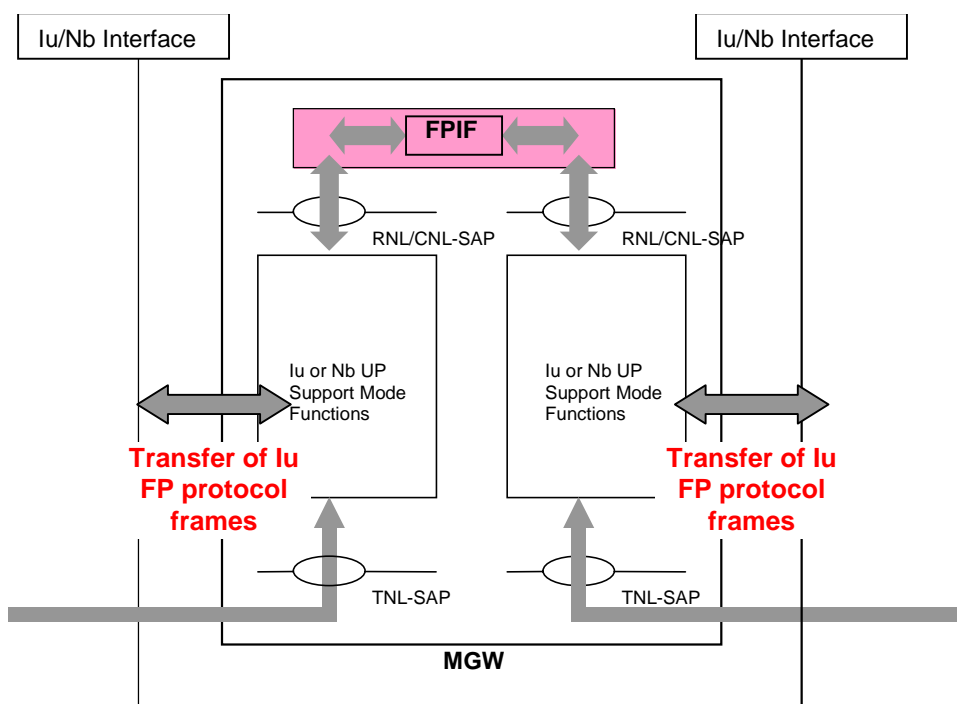

Figure A.1: The Framing Protocol Interworking Function

A.2 FPIF procedures with respect to Iu framing protocol

This clause handles relay of user data indicated to the FPIF in a Nb- or Iu-UP-data-indication message and transmitted between peer UP layer entities in PDU types 0 and 1. The FPIF passes this information to the UP layer on the sending side in a Nb- or Iu-UP-data-request message.

A.2.1 Payload

Received SDUs shall be forwarded unmodified to the next MGW. Note that if "delivery of erroneous SDUs" is set to 'no', faulty SDUs are already discarded by the Iu or Nb support mode functions and, hence, not delivered to the FPIF.

A.2.2 RFCIs

If the RFCI values on the outgoing UP interface match those initialised on the incoming UP interface then the RFCI indicated by the lower layer (i.e. Iu or Nb) on the receiving side shall be forwarded unmodified to lower layer on the sending side.

If the RFCI sets on the outgoing UP interface do not match those initialised on the incoming UP interface then the FPIF performs mapping between the RFCIs on each UP for the same initialised Subflow Combination.

The FPIF is the entity that may perform the RFCI value correction procedure as described in the main text, after this procedure then relaying of the received RFCI shall be performed.

A.2.3 FQC

The FQC indicated by the lower layer (i.e. Iu or Nb) on the receiving side shall be forwarded unmodified to lower layer on the sending side.

A.2.4 Frame number

The frame number indicated by the lower layer (i.e. Iu or Nb) on the receiving side shall be forwarded unmodified to lower layer on the sending side.

A discontinuity in framing protocol support mode frame numbers is allowed at the end of the TrFO break.

A.3 Relay of status information

This clause handles relay of status information indicated to the FPIF in a Nb- or Iu-UP-status-indication message and transmitted between peer UP layer entities in PDU type 14. The FPIF in general passes this information to the UP layer on the sending side.

A.3.1 Void

A.3.2 Rate Control Frames

The FPIF shall pass rate control request and rate control acknowledgement frames transparently between incoming UP interface and outgoing UP interface.

Before a MGW reverts from TrFO break operation (for example during handover or relocation where the rate control procedures may have been operating independently between each UP interface) the FPIF may perform rate control procedures to each UP peer. It shall then use the Maximum rate and Current rate settings from the opposite UP configurations. This is performed to align the UP's on each side of the MGW to enable relaying of all subsequent PDUs as described above.

Optionally, the UP layer protocol entity on the sending side may substitute the frame number received in a status request by another number, but shall then substitute the initial number back in the status indication containing the acknowledgement. Figure A.2 shows an example of the relay of the rate control procedure.

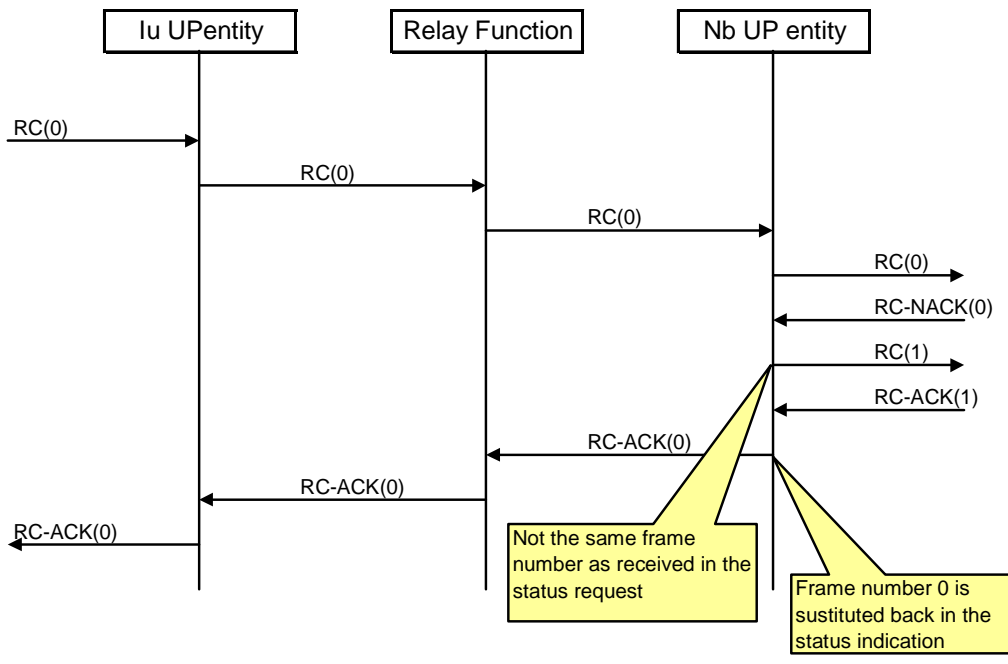

Figure A.2: Relay of a control procedure

A.3.2 Time Alignment

Time alignment frames shall be relayed unmodified.

Annex B (informative): Examples for Usage of the 3GPP Package "Initialization Direction" Property

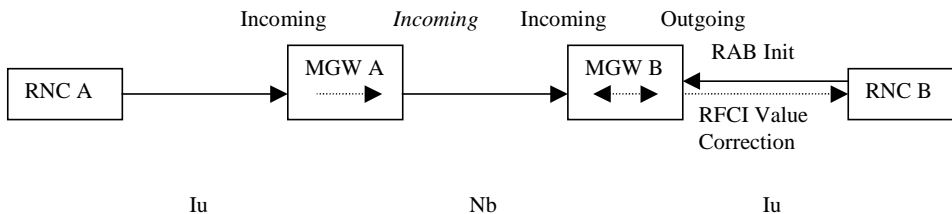

Figure B.1: Mobile to Mobile Call (A to B)

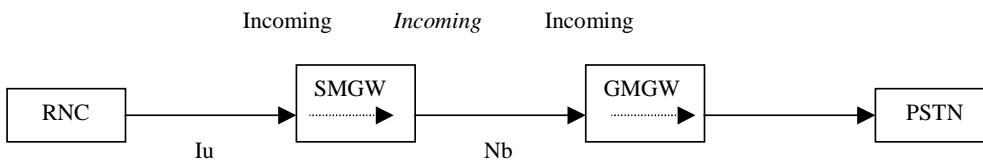

Figure B.2: Mobile Originating Call

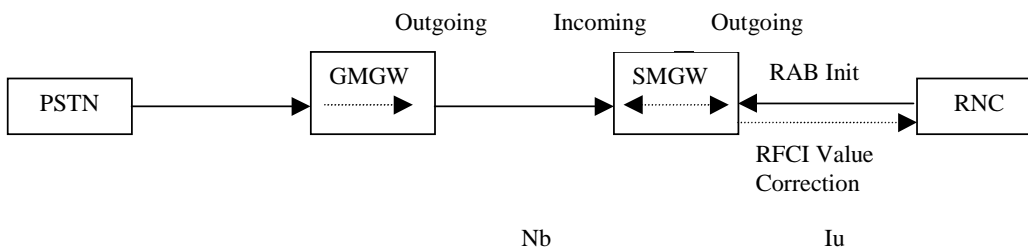

Figure B.3: Mobile Terminating Call

Annex C (informative): Change history

| Change history | | | | | | | |
|----------------|-------|-----------|-----|-----|---|-------|-------|
| Date | TSG # | TSG Doc. | CR | Rev | Subject/Comment | Old | New |
| Sep 2000 | | | | | Initial draft created after N4#4 based on N4-000620 | 0.0.1 | 0.1.0 |
| October 2000 | | | | | Updated after N4 R2000 Ad Hoc Stockholm based on N4-00823 and N4-000842 | 0.1.0 | 0.2.0 |
| Nov 2000 | | | | | Reference for MTP 3B corrected; RFC reference for SCTP added | 0.2.0 | 0.3.0 |
| Nov 2000 | | | | | Updated according to N4-000996, N4-000998, N4-000999, N4-001000, N4-001021, N4-001028 & N4-001097 as agreed in CN4 #5 | 0.3.0 | 1.0.0 |
| Nov 2000 | CN#10 | | | | To TSG-CN Plenary #10 for information | 1.0.0 | 1.1.0 |
| Jan 2001 | | | | | Updated according to NJ-010069, NJ-010030, NJ-010098, NJ-010094, NJ-010033, NJ-010097, NJ-010095, NJ-010112 as agreed in the Joint CN3/CN4 Meeting held during the CN4#6 | 1.1.0 | 1.1.1 |
| Jan 2001 | | | | | References ordered by specification/recommendation number; references to 3GPP specifications include full titles as shown on the title page; literal reference numbers and references to subclauses replaced with fields; all table cells outlined with 0.5pt lines; appropriate 3GPP paragraph styles applied. | 1.1.1 | 1.2.0 |
| Feb 2001 | | | | | Updated according to N4-010245, N4-010248, N4-010249, N4-010303, N4-010304, N4-010305, agreed in CN4 Release 4 ad hoc, Madrid. References to Q.1902.x replaced by references to 29.205; 3GPP styles applied consistently; form for ITU-T recommendations in text is now "ITU-T Recommendation A.NNNN". | 1.2.0 | 1.3.0 |
| Mar 2001 | | | | | Updated according to N4-010384, N4-010401 (part) & N4-010472, agreed in CN4 in Sophia Antipolis. References to Q.1950, Q.1970 and Q.1990 replaced by reference to 29.205. Reference to SIP-T deleted. Editor's note in 15.1.2.3 deleted. Editorial clean-up. | 1.3.0 | 2.0.0 |
| Mar 2001 | | | | | Sent to TSG CN#11 for approval | 2.0.0 | 2.1.0 |
| Mar 2001 | CN#11 | | | | References updated after comments in TSG CN #11 Approved in CN#11 | 2.1.0 | 4.0.0 |
| Jun 2001 | CN#12 | NP-010284 | 1 | 1 | Text encoding of codec information on Mc interface | 4.0.0 | 4.1.0 |
| Jun 2001 | CN#12 | NP-010284 | 4 | 2 | ATM-IP signalling transport Interworking | 4.0.0 | 4.1.0 |
| Jun 2001 | CN#12 | NP-010284 | 5 | 1 | Alignment of Procedure names to TS 23.205 and Q.1950 | 4.0.0 | 4.1.0 |
| Jun 2001 | CN#12 | NP-010284 | 6 | 3 | Clarifications in 3GUP package | 4.0.0 | 4.1.0 |
| Jun 2001 | CN#12 | NP-010284 | 7 | 1 | Clarification of Use of UP version property in 3GUP package | 4.0.0 | 4.1.0 |
| Jun 2001 | CN#12 | NP-010284 | 8 | 1 | Updates to UP Relay Function, Appendix A | 4.0.0 | 4.1.0 |
| Sep 2001 | CN#13 | | | | Editorial clean up | 4.1.0 | 4.2.0 |
| Sep 2001 | CN#13 | NP-010452 | 009 | | Addition of package numbers allocated by IANA | 4.1.0 | 4.2.0 |
| Sep 2001 | CN#13 | NP-010452 | 010 | 1 | Mc signalling transport in IP environment | 4.1.0 | 4.2.0 |
| Dec 2001 | CN#14 | NP-010619 | 011 | 1 | Inclusion of H.248 Annex L, "Error Codes and Service Change Reason Description" | 4.2.0 | 4.3.0 |
| Dec 2001 | CN#14 | NP-010619 | 012 | | Removal of the Reuse Idle Package | 4.2.0 | 4.3.0 |
| Dec 2001 | CN#14 | NP-010619 | 014 | | Correction of Release Procedures | 4.2.0 | 4.3.0 |
| Dec 2001 | CN#14 | NP-010619 | 015 | | Clarification Of Use Of 3GUP package For PCM | 4.2.0 | 4.3.0 |
| Dec 2001 | CN#14 | NP-010619 | 016 | | Corrections to ABNF coding of PackageIDs | 4.2.0 | 4.3.0 |
| Dec 2001 | CN#14 | NP-010619 | 017 | | Correction of BICC packages | 4.2.0 | 4.3.0 |
| Dec 2001 | CN#14 | NP-010619 | 020 | 1 | Correction of 3GUP package sub-list type | 4.2.0 | 4.3.0 |
| Dec 2001 | CN#14 | NP-010631 | 013 | 1 | Introduction of MGW Congestion Handling | 4.3.0 | 5.0.0 |
| Dec 2001 | CN#14 | NP-010631 | 019 | 2 | Maintenance locking of MG | 4.3.0 | 5.0.0 |
| Jan 2002 | | | | | A coverdheet fixed | 5.0.0 | 5.0.1 |
| Mar 2002 | CN#15 | NP-020029 | 025 | 2 | Naming convention for TDM resources | 5.0.1 | 5.1.0 |
| Mar 2002 | CN#15 | NP-020029 | 027 | 2 | Correction of Bearer Modification Handling | 5.0.1 | 5.1.0 |
| Jun 2002 | CN#16 | NP-020260 | 030 | 1 | GTT enhancement on Mc | 5.1.0 | 5.2.0 |
| Jun 2002 | CN#16 | NP-020260 | 032 | | Update to TFO package to explicitly reference TS 26.103 for 3GPP codecs | 5.1.0 | 5.2.0 |
| Jun 2002 | CN#16 | NP-020260 | 033 | 2 | CTM Text Transport package | 5.1.0 | 5.2.0 |
| Jun 2002 | CN#16 | NP-020260 | 034 | | Allow the usage of logical port | 5.1.0 | 5.2.0 |
| Jun 2002 | CN#16 | NP-020249 | 036 | | Correction subclause 14.1.6 of 3GPP TS 29.332 | 5.1.0 | 5.2.0 |
| Sep 2002 | CN#17 | NP-020459 | 037 | 1 | Misalignment between TS 23.226 and TS 29.232 for Global Text Telephony | 5.2.0 | 5.3.0 |
| Sep 2002 | CN#17 | NP-020459 | 038 | 1 | Alignment of text in TS 29.232 for Global Text Telephony | 5.2.0 | 5.3.0 |

| Change history | | | | | | | |
|----------------|-------|-----------|-----|-----|---|-------|-------|
| Date | TSG # | TSG Doc. | CR | Rev | Subject/Comment | Old | New |
| Sep 2002 | CN#17 | NP-020459 | 039 | 1 | Alignment between prepare bearer and reserve bearer in TS 29.232 for Global Text Telephony. | 5.2.0 | 5.3.0 |
| Sep 2002 | CN#17 | NP-020463 | 044 | 1 | Missing Properties For Circuit Switched Data Calls | 5.2.0 | 5.3.0 |
| Dec 2002 | CN#18 | NP-020579 | 041 | 2 | Termination ID Correction | 5.3.0 | 5.4.0 |
| Dec 2002 | CN#18 | NP-020597 | 042 | 3 | New Procedures/Package for handling IP transport for lu interface | 5.3.0 | 5.4.0 |
| Dec 2002 | CN#18 | NP-020578 | 046 | 2 | Updates to support Codec Modification | 5.3.0 | 5.4.0 |
| Dec 2002 | CN#18 | NP-020594 | 052 | 2 | CAMEL4 flexible tone package | 5.3.0 | 5.4.0 |
| Mar 2003 | CN#19 | NP-030108 | 053 | | Update to 3GUP – clarification of luUP Initialisation handling | 5.4.0 | 5.5.0 |
| Mar 2003 | CN#19 | NP-030108 | 054 | 1 | Update to 3GUP – addition of reference to SDU format definition for Nb interface | 5.4.0 | 5.5.0 |
| Jun 2003 | CN#20 | NP-030211 | 057 | 1 | Alignment of references after renumbering of H248 by ITU-T | 5.5.0 | 5.6.0 |
| Jun 2003 | CN#20 | NP-030211 | 059 | | Clarification of handling of DTMF in split architecture – DTMF timing | 5.5.0 | 5.6.0 |
| Mar 2004 | CN#23 | NP-040052 | 061 | | Addition of Package Id for CTM | 5.6.0 | 5.7.0 |
| Mar 2004 | | | | | Addition of Package Ids allocated by IANA (0082 - 0084) | 5.6.0 | 5.7.0 |
| Sep 2004 | CN#25 | NP-040392 | 063 | | Correction of Procedure "Activate Voice Processing Function" | 5.7.0 | 5.8.0 |
| Sep 2004 | CN#25 | NP-040418 | 075 | 2 | 3GUP package corrections | 5.7.0 | 5.8.0 |
| Sep 2004 | CN#25 | NP-040418 | 064 | | Provisioning Of Base Root package properties | 5.7.0 | 5.8.0 |
| Sep 2004 | CN#25 | NP-040418 | 065 | | Service Change Address | 5.7.0 | 5.8.0 |
| Sep 2004 | CN#25 | NP-040418 | 066 | | Use Of Event Buffers | 5.7.0 | 5.8.0 |
| Sep 2004 | CN#25 | NP-040418 | 067 | | Digit Maps | 5.7.0 | 5.8.0 |
| Sep 2004 | CN#25 | NP-040418 | 068 | | IP secured transport | 5.7.0 | 5.8.0 |
| Sep 2004 | CN#25 | NP-040418 | 074 | | Termination Restoration | 5.7.0 | 5.8.0 |
| Sep 2004 | CN#25 | NP-040392 | 072 | 1 | Use Of Statistics | 5.7.0 | 5.8.0 |
| Dec 2004 | CN#26 | NP-040521 | 078 | | Correction of distant codec list | 5.8.0 | 5.9.0 |
| Dec 2004 | CN#26 | NP-040528 | 079 | | IP transport package Duplicate property ID in ASN.1 encoding | 5.8.0 | 5.9.0 |
| Dec 2004 | CN#26 | NP-040529 | 080 | 1 | H.248 Scope | 5.8.0 | 5.9.0 |
| Dec 2004 | CN#26 | NP-040529 | 081 | 1 | Q.1950 reference | 5.8.0 | 5.9.0 |
| Dec 2004 | CN#26 | NP-040529 | 082 | | Emdedded events | 5.8.0 | 5.9.0 |
| Dec 2004 | CN#26 | NP-040529 | 084 | | Multiple streams | 5.8.0 | 5.9.0 |
| Dec 2004 | CN#26 | NP-040529 | 085 | 1 | Overspec/underspec parameters | 5.8.0 | 5.9.0 |
| Dec 2004 | CN#26 | NP-040529 | 088 | 2 | Procedures and Commands – removal of unwanted commands | 5.8.0 | 5.9.0 |
| Dec 2004 | CN#26 | NP-040547 | 092 | | Update of referenced H.248.1 version to version 2 | 5.9.0 | 6.0.0 |
| Mar 2005 | CN#27 | NP-050057 | 060 | 7 | Addition of the trace package | 6.0.0 | 6.1.0 |
| | | NP-050029 | 101 | 1 | Requirements for support of H.248 packages | | |
| | | NP-050029 | 104 | 1 | Completion of specification of UMTS Packages | | |
| | | NP-050036 | 106 | | Correction of implied option for Embedded Signals and Events | | |
| | | NP-050036 | 108 | 2 | Removal of the "Test" ServiceStates value from the TerminationState Descriptor | | |
| | | NP-050036 | 111 | 1 | Removal of the usage of the ContextAttributeAuditReq construct | | |
| | | NP-050036 | 113 | | Removal of the Multiplex descriptor | | |
| | | NP-050036 | 115 | | Removal of the Modem descriptor | | |
| | | NP-050133 | 120 | 4 | Requirements for support of procedures | | |
| | | NP-050034 | 122 | 2 | Procedure for Emergency Call Indication | | |
| | | NP-050036 | 128 | | Removal of the Error Descriptor usage in NotifyRequest | | |
| | | NP-050036 | 130 | | Updating incomplete parameter definition for MGW Resource congestion handling procedures | | |
| | | NP-050055 | 131 | | Removal of Signals on ROOT | | |
| | | NP-050055 | 132 | | Removal of usage of Stream ID in Topology descriptor | | |
| | | NP-050055 | 133 | | H.248.1 version contradiction | | |
| | | NP-050036 | 135 | | Directionality of tones and announcements | | |
| | | NP-050036 | 138 | 1 | New "TFO status" event | | |
| | | NP-050028 | 139 | 1 | TFO procedure clarification | | |
| | | NP-050028 | 142 | 1 | TFO activation without TFO Codec List | | |
| | | NP-050036 | 148 | 1 | Commands on ROOT | | |
| | | NP-050036 | 149 | 1 | Use Of Audit Value | | |
| | | NP-050036 | 151 | | Service Change Reasons Not supported | | |
| | | NP-050036 | 155 | 1 | Descriptors in command replies | | |
| | | NP-050036 | 157 | 1 | Introduction of formal profile name for Mc interface | | |
| | | NP-050036 | 158 | | Service Change for Failover not defined for Mc Interface | | |
| | | NP-050029 | 161 | | Removal Of VPF type | | |
| | | NP-050029 | 164 | | Alignment of TFO Actvation Procedure and associated parameters | | |
| | | NP-050055 | 165 | 2 | Continuity Test | | |
| Jun 2005 | CT#28 | CP-050236 | 184 | 1 | BNC Cut-Through Capability Package Removed | 6.1.0 | 6.2.0 |
| | | CP-050236 | 187 | 1 | Format of IP address | | |
| | | CP-050101 | 188 | 2 | Profile Registration Mandatory/Negotiation Clarification | | |
| | | CP-050236 | 196 | 1 | Clarification of Maintenance Procedures | | |
| | | CP-050236 | 198 | 1 | Clarification of Use Of Topology and Multiparty | | |

| Change history | | | | | | | |
|----------------|-------|-----------|------|-----|---|-------|-------|
| Date | TSG # | TSG Doc. | CR | Rev | Subject/Comment | Old | New |
| | | CP-050236 | 200 | | Removal of Option in Prepare Bearer that the MGW can chose the BNC Characteristics | | |
| | | CP-050236 | 202 | 1 | Clarification Of Use of Wildcarding | | |
| | | CP-050080 | 209 | 2 | Text encoding of IPBCP for IP transport on Mc interface | | |
| | | CP-050080 | 212 | 2 | Definition of requirement for support of commands | | |
| | | CP-050238 | 213 | 1 | Correction to Profile registration procedures | | |
| Sep 2005 | CT#29 | CP-050435 | 218 | 1 | Codec IE and Codec List on the Mc interface | 6.2.0 | 6.3.0 |
| | | CP-050290 | 224 | | Value range for BIR/NSAP | | |
| | | CP-050290 | 229 | | Clarification of "extended only" packages | | |
| | | CP-050290 | 231 | | Correction to Prepare IP Transport procedure | | |
| | | CP-050290 | 233 | 1 | Wildcarding of Release Procedures | | |
| | | CP-050290 | 235 | | Clarification to use of local peer for CSD | | |
| | | CP-050280 | 238 | 2 | Correction to clarify use of FAX and Channel Mode Modify | | |
| | | CP-050290 | 242 | 1 | Clarification to use of PLMN-BC, GSM-Chanel Coding for CSD | | |
| | | CP-050290 | 244 | 1 | Clarification to use of Init Dir parameter | | |
| | | CP-050290 | 246 | 1 | Clarification to Termination Restoration and Termination Out Of Service | | |
| | | CP-050290 | 248 | | Remove provisioning of Resource Congestion Event | | |
| | | CP-050290 | 250 | | Remove Priority property | | |
| | | CP-050290 | 252 | | Notifications for IP Bearer Establishment | | |
| | | CP-050290 | 254 | 1 | Clarification for Use of Stream Mode Property with Announcements | | |
| | | CP-050290 | 256 | | Removal of Stream Mode Loopback | | |
| | | CP-050290 | 258 | | Correction to IPBCP Tunnel Procedures | | |
| | | CP-050290 | 263 | | Exclusion of use of Signal ID Play Tone for DTMF | | |
| | | CP-050290 | 265 | 1 | Miscellaneous Open Mc corrections | | |
| | | CP-050308 | 266 | 1 | Use of Individual Audit Token | | |
| | | CP-050438 | 268 | 1 | Restriction of Service Change Address in MGW Restriction | | |
| | | CP-050308 | 271 | | Removal of BNC-cut-through-capability from Prepare Bearer procedure | | |
| | | CP-050308 | 272 | | Updating Mc interface profile "threegbicsn" to version 2 | | |
| | | CP-050290 | 276 | | Defining a default value for "Echo cancelling" property | | |
| | | CP-050309 | 278 | 1 | Correction on Burst interval duration | | |
| | | CP-050308 | 281 | 1 | Clarification of "Normal Release" parameter | | |
| 2005-12 | CT#30 | CP-050603 | 0261 | 2 | Correction to clarify TFO Package use | 6.3.0 | 6.4.0 |
| | | CP-050607 | 0288 | 1 | Clarification to client/server behaviour with regards to SCTP Initiation | | |
| | | CP-050607 | 0289 | 1 | Inclusion of Error Code #449 for unsupported parameter value | | |
| | | CP-050618 | 0290 | 1 | Correction to Continuity Test Procedure | | |
| | | CP-050607 | 0296 | 1 | Setting of CN/Outgoing Nb termination prior to bearer establishment | | |
| | | CP-050607 | 0304 | 2 | Correction to use of BITRATE for CSD calls | | |
| | | CP-050607 | 0308 | 1 | Bearer Released Event to Reserve Circuit procedure | | |
| | | CP-050607 | 0322 | 1 | Corrections to use of GSM-Channel Coding for CSD | | |
| | | CP-050618 | 0323 | 3 | Correct MCC Error in implementing CR #238 | | |
| 2006-03 | CT#31 | CP-060064 | 0286 | 3 | Correction To Termination State Handling | 6.4.0 | 6.5.0 |
| | | CP-060064 | 0328 | 1 | Send Tone procedure | | |
| | | CP-060064 | 0332 | 1 | Correction To DTMF Detection | | |
| | | CP-060064 | 0344 | 2 | Adding missing termination ID to Acknowledgement part of notification procedures | | |
| | | CP-060064 | 0347 | | Adding missing Codec, Bearer Characteristics and Bearer Service Characteristics to Prepare IP transport procedure | | |
| | | CP-060064 | 0361 | | ContextID in Change Flow Direction response | | |
| | | CP-060067 | 0362 | | Correction on the used descriptor for trace package | | |
| 2006-06 | CT#32 | CP-060301 | 0364 | 2 | DTMF Detection Type | 6.5.0 | 6.6.0 |
| | | | 0373 | 2 | Multimedia & CSD calls | | |
| | | | 0367 | 1 | Sequential Signal Lists | | |
| | | | 0384 | 1 | Clarification of ROOT termination naming | | |
| | | CP-060307 | 0369 | | Corrigendum for H.248.1 version 2 | | |
| 2006-09 | CT#33 | CP-060402 | 0408 | | Trace Package ID | 6.6.0 | 6.7.0 |
| | | CP-060402 | 0426 | | Wildcarding of Release Termination Response | | |
| | | CP-060402 | 0446 | | Incomplete list of optional UMTS packages | | |
| | | CP-060400 | 0403 | 3 | Profile registration procedure | | |
| | | CP-060400 | 0411 | | AuditValue procedure | | |
| | | CP-060400 | 0414 | 1 | Use of topology for tones and announcements | | |
| | | CP-060400 | 0429 | | Correction to Emergency Call Indication Procedure | | |
| | | CP-060400 | 0435 | 1 | Use of IPSec for Mc Interface | | |
| | | CP-060400 | 0438 | 2 | Correction to use of Local Peer for CSD when Anchor MGW | | |
| | | CP-060400 | 0445 | | Clarification of H.248.2 version in references | | |

| Change history | | | | | | | |
|----------------|-------|-----------|------|-------------|---|-------|-------|
| Date | TSG # | TSG Doc. | CR | R e v | Subject/Comment | Old | New |
| | | CP-060397 | 0419 | | Modification of eventId named distant_codec_list in threegtfo package | | |
| 2006-12 | CT#34 | CP-060552 | 0458 | | Encoding of PLMN BC | 6.7.0 | 6.8.0 |
| | | CP-060561 | 0460 | | Trace package correction | | |
| | | CP-060554 | 0463 | | Commands in Change flow direction procedure | | |
| | | CP-060718 | 0480 | 3 | Definite vs Indefinite encoding rules for binary H.248 | | |
| 2007-03 | CT#35 | CP-070009 | 0496 | | Exclusion of use of inherited properties from network package | 6.8.0 | 6.9.0 |
| | | | 0500 | 1 | Signal List ID to Announcement Completed procedure | | |

History

| Document history | | |
|-------------------------|----------------|-------------|
| V6.0.0 | December 2004 | Publication |
| V6.1.0 | March 2005 | Publication |
| V6.2.0 | June 2005 | Publication |
| V6.3.0 | September 2005 | Publication |
| V6.4.0 | December 2005 | Publication |
| V6.5.0 | March 2006 | Publication |
| V6.6.0 | June 2006 | Publication |
| V6.7.0 | September 2006 | Publication |
| V6.8.0 | December 2006 | Publication |
| V6.9.0 | March 2007 | Publication |