

ETSI TS 132 346 V12.0.0 (2014-10)



**Digital cellular telecommunications system (Phase 2+);
Universal Mobile Telecommunications System (UMTS);
LTE;
Telecommunication management;
File Transfer (FT) Integration Reference Point (IRP):
Solution Set (SS) definitions
(3GPP TS 32.346 version 12.0.0 Release 12)**



Reference

RTS/TSGS-0532346vc00

Keywords

GSM,LTE,UMTS

ETSI

650 Route des Lucioles
F-06921 Sophia Antipolis Cedex - FRANCE

Tel.: +33 4 92 94 42 00 Fax: +33 4 93 65 47 16

Siret N° 348 623 562 00017 - NAF 742 C
Association à but non lucratif enregistrée à la
Sous-Préfecture de Grasse (06) N° 7803/88

Important notice

The present document can be downloaded from:

<http://www.etsi.org>

The present document may be made available in electronic versions and/or in print. The content of any electronic and/or print versions of the present document shall not be modified without the prior written authorization of ETSI. In case of any existing or perceived difference in contents between such versions and/or in print, the only prevailing document is the print of the Portable Document Format (PDF) version kept on a specific network drive within ETSI Secretariat.

Users of the present document should be aware that the document may be subject to revision or change of status. Information on the current status of this and other ETSI documents is available at

<http://portal.etsi.org/tb/status/status.asp>

If you find errors in the present document, please send your comment to one of the following services:

http://portal.etsi.org/chaicor/ETSI_support.asp

Copyright Notification

No part may be reproduced or utilized in any form or by any means, electronic or mechanical, including photocopying and microfilm except as authorized by written permission of ETSI.

The content of the PDF version shall not be modified without the written authorization of ETSI.

The copyright and the foregoing restriction extend to reproduction in all media.

© European Telecommunications Standards Institute 2014.

All rights reserved.

DECT™, **PLUGTESTS™**, **UMTS™** and the ETSI logo are Trade Marks of ETSI registered for the benefit of its Members. **3GPP™** and **LTE™** are Trade Marks of ETSI registered for the benefit of its Members and of the 3GPP Organizational Partners.
GSM® and the GSM logo are Trade Marks registered and owned by the GSM Association.

Intellectual Property Rights

IPRs essential or potentially essential to the present document may have been declared to ETSI. The information pertaining to these essential IPRs, if any, is publicly available for **ETSI members and non-members**, and can be found in ETSI SR 000 314: *"Intellectual Property Rights (IPRs); Essential, or potentially Essential, IPRs notified to ETSI in respect of ETSI standards"*, which is available from the ETSI Secretariat. Latest updates are available on the ETSI Web server (<http://ipr.etsi.org>).

Pursuant to the ETSI IPR Policy, no investigation, including IPR searches, has been carried out by ETSI. No guarantee can be given as to the existence of other IPRs not referenced in ETSI SR 000 314 (or the updates on the ETSI Web server) which are, or may be, or may become, essential to the present document.

Foreword

This Technical Specification (TS) has been produced by ETSI 3rd Generation Partnership Project (3GPP).

The present document may refer to technical specifications or reports using their 3GPP identities, UMTS identities or GSM identities. These should be interpreted as being references to the corresponding ETSI deliverables.

The cross reference between GSM, UMTS, 3GPP and ETSI identities can be found under <http://webapp.etsi.org/key/queryform.asp>.

Modal verbs terminology

In the present document "**shall**", "**shall not**", "**should**", "**should not**", "**may**", "**may not**", "**need**", "**need not**", "**will**", "**will not**", "**can**" and "**cannot**" are to be interpreted as described in clause 3.2 of the [ETSI Drafting Rules](#) (Verbal forms for the expression of provisions).

"**must**" and "**must not**" are **NOT** allowed in ETSI deliverables except when used in direct citation.

Contents

Intellectual Property Rights	2
Foreword.....	2
Modal verbs terminology.....	2
Foreword.....	5
Introduction	5
1 Scope	6
2 References	6
3 Definitions and abbreviations.....	7
3.1 Definitions	7
3.2 Abbreviations	7
4 Solution Set Definitions	7
Annex A (normative): CORBA Solution Set	8
A.1 Architectural features	8
A.1.1 Syntax for Distinguished Names	8
A.1.2 Notification Services	8
A.1.3 Push and Pull Style.....	8
A.1.4 Support multiple notifications in one push operation.....	8
A.1.5 FileTransferIRP Notification Interface.....	8
A.1.5.1 Method push (M)	8
A.2 Mapping	9
A.2.1 Operation and Notification mapping	9
A.2.2 Operation parameter mapping	9
A.2.3 Notification parameter mapping.....	10
A.3 Solution Set definitions	12
A.3.1 IDL definition structure.....	12
A.3.2 IDL specification "FileTransferIRPConstDefs.idl"	13
A.3.3 IDL specification "FileTransferIRPSystem.idl"	14
A.3.4 IDL specification "FileTransferIRPNotifications.idl"	15
Annex B (normative): XML Definitions	17
B.1 Architectural Features	17
B.1.1 Syntax for Distinguished Names	17
B.1.2 Notification Services	17
B.1.3 IOC Definitions	17
B.2 Mapping	17
B.3 Solution Set definitions	17
B.3.1 XML definition structure.....	17
B.3.2 Graphical Representation	18
B.3.3 XML Schema 'FTIRPNotif.xsd'	18
B.3.4 XML Schema 'FTIRPIOCs.xsd'	19
Annex C (normative): SOAP Solution Set	21
C.1 Architectural features	21
C.1.1 Syntax for Distinguished Names	21
C.1.2 Notification Services	21
C.1.3 Supported W3C specifications	21
C.1.4 Prefixes and namespaces	21

C.2	Mapping	22
C.2.1	Operation and notification mapping	22
C.2.2	Operation parameter mapping	22
C.2.2.1	Operation listAvailableFiles	22
C.2.2.1.1	Input parameters	22
C.2.2.1.2	Output parameters	23
C.2.2.1.3	Fault definition	23
C.2.2.2	Operation fileDownloadIndication	23
C.2.2.2.1	Input parameters	23
C.2.2.2.2	Output parameters	23
C.2.2.2.3	Fault definition	23
C.3	Solution Set definitions	24
C.3.1	WSDL definition structure	24
C.3.2	Graphical Representation	24
C.3.3	WSDL specification 'FTRPSystem.wsdl'	24
Annex D (informative):	Change history	27
History		28

Foreword

This Technical Specification (TS) has been produced by the 3rd Generation Partnership Project (3GPP).

The contents of the present document are subject to continuing work within the TSG and may change following formal TSG approval. Should the TSG modify the contents of the present document, it will be re-released by the TSG with an identifying change of release date and an increase in version number as follows:

Version x.y.z

where:

- x the first digit:
 - 1 presented to TSG for information;
 - 2 presented to TSG for approval;
 - 3 or greater indicates TSG approved document under change control.
- y the second digit is incremented for all changes of substance, i.e. technical enhancements, corrections, updates, etc.
- z the third digit is incremented when editorial only changes have been incorporated in the document.

Introduction

The present document is part of a TS-family covering the 3rd Generation Partnership Project; Technical Specification Group Services and System Aspects; Telecommunication management, as identified below:

- 32.341: "File Transfer (FT) Integration Reference Point (IRP): Requirements"
- 32.342: "File Transfer (FT) Integration Reference Point (IRP): Information Service (IS)"
- 32.346: "File Transfer (FT) Integration Reference Point (IRP): Solution Set (SS) definitions"**

The present document is part of a TS-family which describe the requirements and information model necessary for the Telecommunication Management (TM) of 3G systems. The TM principles and TM architecture are specified in 3GPP TS 32.101 [1] and 3GPP TS 32.102 [2].

Network Elements (NEs) under management, element managers as well as network managers generate various management information stored in file format. This IRP is addressing how these files are exchanged through Itf-N as well as certain aspects of file management and maintenance. It is anticipated that management functions (e.g. PM, Call Trace, CM) make reuse of capabilities provided by this File Transfer IRP.

1 Scope

The present document contains the Solution Sets for the IRP whose semantics are specified in File Transfer IRP: Information Service (3GPP TS 32.342 [15]).

This Solution Set specification is related to 3GPP TS 32.342 V12.0.X.

2 References

The following documents contain provisions which, through reference in this text, constitute provisions of the present document.

- References are either specific (identified by date of publication, edition number, version number, etc.) non-specific.
- For a specific reference, subsequent revisions do not apply.
- For a non-specific reference, the latest version applies. In the case of a reference to a 3GPP document (including a GSM document), a non-specific reference implicitly refers to the latest version of that document *in the same Release as the present document*.

- [1] 3GPP TS 32.101: "Telecommunication management; Principles and high level requirements".
- [2] 3GPP TS 32.102: "Telecommunication management; Architecture".
- [3] 3GPP TS 32.341: "Telecommunication management; File Transfer (FT) Integration Reference Point (IRP): Requirements".
- [4] 3GPP TS 32.311: "Telecommunication management; Generic Integration Reference Point (IRP) management; Requirements".
- [5] 3GPP TS 32.306: "Telecommunication management; Configuration Management (CM); Notification Integration Reference Point (IRP): Solution Set (SS) definitions".
- [6] 3GPP TS 32.300: "Telecommunication management; Configuration Management (CM); Name convention for Managed Objects".
- [7] 3GPP TS 32.312: "Telecommunication management; Generic Integration Reference Point (IRP) management; Information Service (IS)".
- [8] 3GPP TS 32.316: "Telecommunication management; Generic Integration Reference Point (IRP) management; Solution Set (SS) definitions".
- [9] 3GPP TS 32.150: "Telecommunication management; Integration Reference Point (IRP) Concept and definitions".
- [10] OMG TC Document telecom/98-11-01: "OMG Notification Service".
<http://www.omg.org/technology/documents/>
- [11] W3C SOAP 1.1 specification (<http://www.w3.org/TR/2000/NOTE-SOAP-20000508/>)
- [12] W3C XPath 1.0 specification (<http://www.w3.org/TR/1999/REC-xpath-19991116>)
- [13] W3C WSDL 1.1 specification (<http://www.w3.org/TR/2001/NOTE-wsdl-20010315>)
- [14] W3C SOAP 1.2 specification (<http://www.w3.org/TR/soap12-part1/>)
- [15] 3GPP TS 32.342: "Telecommunication management; File Transfer (FT) Integration Reference Point (IRP): Information Service (IS)".
- [16] 3GPP TS 32.336: "Telecommunication management; Notification Log (NL) Integration Reference Point (IRP): Solution Set (SS) definitions".

- [17] 3GPP TS 32.331: "Telecommunication management; Notification Log (NL) Integration Reference Point (IRP): Requirements".

3 Definitions and abbreviations

3.1 Definitions

For the purposes of the present document, the terms and definitions given in 3GPP TS 32.101 [1], 3GPP TS 32.102 [2], 3GPP TS 32.150 [9], 3GPP TS 32.331 [17] and 3GPP TS 32.341 [3] and the following apply:

IRP document version number string (or "IRPVersion"): See 3GPP TS 32.311 [4].

3.2 Abbreviations

For the purposes of the present document, the following abbreviations apply:

CM	Configuration Management
CORBA	Common Object Request Broker Architecture
DN	Distinguished Name
FT	File Transfer
FTIRP	File Transfer IRP
IDL	Interface Definition Language
IRP	Integration Reference Point
IS	Information Service
NE	Network Element
NL	Notification Log
NRM	Network Resource Model
OMG	Object Management Group
PM	Performance Management
SS	Solution Set
UML	Unified Modelling Language
WSDL	Web Service Description Language
XML	eXtensible Markup Language

4 Solution Set Definitions

This specification defines the following 3GPP FT IRP Solution Set Definitions:

Annex A provides the CORBA Solution Set.

Annex B provides the XML Definitions.

Annex C provides the SOAP Solution Set.

Annex A (normative): CORBA Solution Set

This annex contains the CORBA Solution Set for the IRP whose semantics is specified in FT IRP: Information Service (3GPP TS 32.342 [15]).

A.1 Architectural features

The overall architectural feature of FT IRP is specified in 3GPP TS 32.341 [3].

This clause specifies features that are specific to the CORBA SS.

A.1.1 Syntax for Distinguished Names

The syntax of a Distinguished Name is defined in 3GPP TS 32.300 [6].

A.1.2 Notification Services

In implementations of CORBA SS, IRPAgent conveys FT Information to IRPManager via OMG Notification Service (OMG Notification Service [10]).

A necessary and sufficient sub set of OMG Notification Services shall be used to support `FileTransferIRPNotifications` notifications as specified in 3GPP TS 32.342 [15].

A.1.3 Push and Pull Style

OMG Notification Service defines two styles of interaction. One is called push style. In this style, IRPAgent pushes notifications to IRPManager as soon as they are available. The other is called pull style. In this style, IRPAgent keeps the notifications till IRPManager requests for them.

This CORBA SS specifies that support of Push style is Mandatory (M) and that support of Pull style is Optional (O).

A.1.4 Support multiple notifications in one `push` operation

For efficiency reasons, IRPAgent may send multiple notifications using one single push operation. To pack multiple notifications into one push operation, IRPAgent may wait and not invoke the push operation as soon as notifications are available. To avoid IRPAgent to wait for an extended period of time that is objectionable to IRPManager, IRPAgent shall implement an IRPAgent wide timer configurable by administrator. On expiration of this timer, IRPAgent shall invoke push if there is at least one notification to be conveyed to IRPManager. This timer is re-started after each push invocation.

A.1.5 FileTransferIRP Notification Interface

OMG CORBA Notification push operation is used to realise the notification of FileTransferIRP Notifications. All the notifications in this interface are implemented using this `push_structured_event` method.

A.1.5.1 Method `push` (M)

```
module CosNotifyComm {
...
  Interface SequencePushConsumer : NotifyPublish {
    void push_structured_events(
      in CosNotification::EventBatch notifications)
  }
}
```

```

        raises( CosEventComm::Disconnected);
    ...
}; // SequencePushConsumer
...
}; // CosNotifyComm

```

NOTE 1: The `push_structured_events` method takes an input parameter of type `EventBatch` as defined in the `OMG CosNotification` module (OMG Notification Service [10]). This data type is the same as a sequence of Structured Events. Upon invocation, this parameter will contain a sequence of Structured Events being delivered to `IRPManager` by `IRPAgent` to which it is connected.

NOTE 2: The maximum number of events that will be transmitted within a single invocation of this operation is controlled by `IRPAgent` wide configuration parameter.

NOTE 3: The amount of time the supplier (`IRPAgent`) of a sequence of Structured Events will accumulate individual events into the sequence before invoking this operation is controlled by `IRPAgent` wide configuration parameter as well.

NOTE 4: `IRPAgent` may push `EventBatch` with only one Structured Event.

A.2 Mapping

A.2.1 Operation and Notification mapping

`FileTransferIRP`: IS 3GPP TS 32.342 [15] defines semantics of operation and notification visible across the `FileTransferIRP`. Table A.2.1 indicates mapping of these operations and notifications to their equivalents defined in this SS.

Table A.2.1: Mapping from IS Operations and Notification to SS equivalents

IS Operations/ notification 3GPP TS 32.342 [15]	SS Method	Qualifier
<code>listAvailableFiles</code>	<code>list_available_files</code>	M
<code>fileDownloadIndication</code>	<code>file_download_indication</code>	O
<code>getIRPVersion</code> (see note)	<code>get_file_transfer_irp_versions</code>	M
<code>getOperationProfile</code> (see note)	<code>get_file_transfer_irp_operations_profile</code>	O
<code>getNotificationProfile</code> (see note)	<code>get_file_transfer_irp_notifications_profile</code>	O
<code>notifyFileReady</code>	<code>push_structured_events</code> (see subclause A.1.5)	M
<code>notifyFilePreparationError</code>	<code>push_structured_events</code> (see subclause A.1.5)	M
NOTE: This operation is of <code>ManagedGenericIRP</code> IOC specified in 3GPP TS 32.312 [7]. The <code>FileTransferIRP</code> IOC of 3GPP TS 32.342 [15] inherits from it.		

A.2.2 Operation parameter mapping

The `FileTransferIRP`: IS 3GPP TS 32.342 [15] defines semantics of parameters carried in operations across the `FileTransferIRP`. The following tables indicate the mapping of these parameters, as per operation, to their equivalents defined in this SS.

Table A.2.2.1: Mapping from IS `listAvailableFiles` parameters to SS equivalents

IS Operation parameter	SS Method parameter	Qualifier
<code>managementDataType</code>	<code>short management_data_type</code>	M
<code>beginTime</code>	<code>FileTransferIRPConstDefs::UTCTime begin_time</code>	M
<code>endTime</code>	<code>FileTransferIRPConstDefs::UTCTime end_time</code>	M
<code>fileInfoList</code>	<code>FileTransferIRPConstDefs::FileInfoList file_info_list</code>	M
<code>status</code>	Return value of type <code>FileTransferIRPConstDefs::Result</code> Exception: <code>ListAvailableFiles</code> , <code>InvalidTimes</code> , <code>ManagedGenericIRPSystem::InvalidParameter</code>	M

Table A.2.2.2: Mapping from IS fileDownloadIndication parameters to SS equivalents

IS Operation parameter	SS Method parameter	Qualifier
fileInfoList	FileTransferIRPConstDefs::FileInfoList file_info_list	M
status	Return value of type FileTransferIRPConstDefs::Result Exception: FileDownloadIndication, InvalidFileInfoList, ManagedGenericIRPSystem:OperationNotSupported	M

Table A.2.2.3: Mapping from IS getIRPVersion parameters to SS equivalents

IS Operation parameter	SS Method parameter	Qualifier
versionNumberSet	Return value of type ManagedGenericIRPConstDefs::VersionNumberSet	M
status	Exception: GetFileTransferIRPVersions	M

Table A.2.2.4: Mapping from IS getOperationProfile parameters to SS equivalents

IS Operation parameter	SS Method parameter	Qualifier
iRPVersion	ManagedGenericIRPConstDefs::VersionNumber irp_version	M
operationNameProfile, operationParameterProfile	Return value of type ManagedGenericIRPConstDefs::MethodList	M
status	Exception: GetFileTransferIRPOperationsProfile, ManagedGenericIRPSystem::OperationNotSupported, ManagedGenericIRPSystem::InvalidParameter	M

Table A.2.2.5: Mapping from IS getNotificationProfile parameters to SS equivalents

IS Operation parameter	SS Method parameter	Qualifier
iRPVersion	ManagedGenericIRPConstDefs::VersionNumber irp_version	M
notificationNameProfile, notificationParameterProfile	Return value of type ManagedGenericIRPConstDefs::MethodList	M
status	Exception: GetFileTransferIRPNotificationsProfile, ManagedGenericIRPSystem::OperationNotSupported, ManagedGenericIRPSystem::InvalidParameter	M

A.2.3 Notification parameter mapping

The FileTransferIRP: IS 3GPP TS 32.342 [15] defines semantics of parameters carried in notifications. The following table indicates the mapping of these parameters to their OMG CORBA Structured Event (defined in OMG Notification Service [10]) equivalents. The composition of OMG Structured Event, as defined in the OMG Notification Service [10], is:

```
Header
  Fixed Header
    domain_name
    type_name
    event_name
  Variable Header
Body
  filterable_body_fields
  remaining_body
```

The following tables list all OMG Structured Event attributes in the second column. The first column identifies the FileTransferIRP: IS 3GPP TS 32.342 [15] defined notification parameters.

Table A.2.3.1: Mapping for notifyFileReady

IS Parameters	OMG CORBA Structured Event attribute	Qualifier	Comment
There is no corresponding IS attribute.	domain_name	M	It carries the IRP document version number string. See subclause 3.1. It indicates the syntax and semantics of the Structured Event as defined by the present document.
notificationType	type_name	M	This is the ET_FILE_READY of module of FileTransferIRPNotifDefs.
There is no corresponding IS attribute.	event_name	M	It carries no information.
There is no corresponding IS attribute.	Variable Header		
objectClass, objectInstance	One NV pair of filterable_body_fields	M	NV stands for name-value pair. Order arrangement of NV pairs is not significant. The name of NV-pair is always encoded in string. Name of this NV pair is the MANAGED_OBJECT_INSTANCE of interface AttributeNameValue of module NotificationIRPConstDefs. Value of NV pair is a string. See corresponding table in Notification IRP: CORBA SS (3GPP TS 32.306 [5]).
notificationId	One NV pair of remaining_body	M	Name of NV pair is the NOTIFICATION_ID of interface AttributeNameValue of module NotificationIRPConstDefs. Value of NV pair is a long. See corresponding table in Notification IRP: CORBA SS (3GPP TS 32.306 [5]).
eventTime	One NV pair of filterable_body_fields	M	Name of NV pair is the EVENT_TIME of interface AttributeNameValue of module NotificationIRPConstDefs. Value of NV pair is IRPTime. See corresponding table in Notification IRP: CORBA SS (3GPP TS 32.306 [5]).
systemDN	One NV pair of filterable_body_fields	M	Name of NV pair is the SYSTEM_DN of interface AttributeNameValue of module NotificationIRPConstDefs. Value of NV pair is a string. See corresponding table in Notification IRP: CORBA SS (3GPP TS 32.306 [5]).
fileInfoList	One NV pair of remaining_body	M	Name of NV pair is the FILE_INFO_LIST of interface NotifyFileReady of module FileTransferIRPNotifications. Value of NV pair is FileInfoList of module FileTransferIRPConstDefs.
additionalText	One NV pair of remaining_body	O	Name of NV pair is the ADDITIONAL_TEXT interface NotifyFileReady of module FileTransferIRPNotifications. Value of NV pair is a string.

Table A.2.3.2: Mapping for notifyFilePreparationError

IS Parameters	OMG CORBA Structured Event attribute	Qualifier	Comment
There is no corresponding IS attribute.	domain_name	M	It carries the IRP document version number string. See subclause 3.1. It indicates the syntax and semantics of the Structured Event as defined by the present document.
notificationType	Type_name	M	This is the ET_FILE_PREPARATION_ERROR of module of FileTransferIRPNotifDefs.
There is no corresponding IS attribute.	event_name	M	It carries no information.

IS Parameters	OMG CORBA Structured Event attribute	Qualifier	Comment
There is no corresponding IS attribute.	Variable Header		
objectClass, objectInstance	One NV pair of filterable_body_fields	M	NV stands for name-value pair. Order arrangement of NV pairs is not significant. The name of NV-pair is always encoded in string. Name of this NV pair is the MANAGED_OBJECT_INSTANCE of interface AttributeNameValue of module NotificationIRPConstDefs. Value of NV pair is a string. See corresponding table in Notification IRP: CORBA SS (3GPP TS 32.306 [5]).
notificationId	One NV pair of remaining_body	M	Name of NV pair is the NOTIFICATION_ID of interface AttributeNameValue of module NotificationIRPConstDefs. Value of NV pair is a long. See corresponding table in Notification IRP: CORBA SS (3GPP TS 32.306 [5]).
eventTime	One NV pair of filterable_body_fields	M	Name of NV pair is the EVENT_TIME of interface AttributeNameValue of module NotificationIRPConstDefs. Value of NV pair is IRPTime. See corresponding table in Notification IRP: CORBA SS (3GPP TS 32.306 [5]).
systemDN	One NV pair of filterable_body_fields	M	Name of NV pair is the SYSTEM_DN of interface AttributeNameValue of module NotificationIRPConstDefs. Value of NV pair is a string. See corresponding table in Notification IRP: CORBA SS (3GPP TS 32.306 [5]).
fileInfoList	One NV pair of remaining_body	M	Name of NV pair is the FILE_INFO_LIST of interface NotifyFilePreparationError of module FileTransferIRPNotifications. Value of NV pair is FileInfoList of module FileTransferIRPConstDefs.
reason	One NV pair of remaining_body	M	Name of NV pair is the REASON of interface NotifyFilePreparationError of module FileTransferIRPNotifications. Value of NV pair is a string.
additionalText	One NV pair of remaining_body	O	Name of NV pair is the ADDITIONAL_TEXT of interface NotifyFilePreparationError of module FileTransferIRPNotifications. Value of NV pair is a string.

A.3 Solution Set definitions

A.3.1 IDL definition structure

Clause A.3.2 defines the constants and types used by the FT IRP.

Clause A.3.3 defines the operations which are performed by the FT IRP agent.

Clause A.3.4 defines the notifications which are emitted by the FT IRP agent.

A.3.2 IDL specification "FileTransferIRPConstDefs.idl"

```

//File: FileTransferIRPConstDefs.idl
#ifndef _FILE_TRANSFER_IRP_CONST_DEFS_IDL_
#define _FILE_TRANSFER_IRP_CONST_DEFS_IDL_

#include <TimeBase.idl>

// This statement must appear after all include statements
#pragma prefix "3gppsa5.org"

/* ## Module: FileTransferIRPConstDefs
This module contains commonly used definitions for FileTransferIRP.
=====
*/
module FileTransferIRPConstDefs
{
    enum Result {OK, FAILURE};

    typedef TimeBase::UtcT UTCTime;

    enum LocationChoice {DIRECTORY, URL};

    //The FileLocation may be a directory path or a URL
    union FileLocation switch (LocationChoice)
    {
        case DIRECTORY: string file_location_directory;
        /* e.g. \\202.112.101.1\D:\user\performanceFiles\ */
        case URL: string file_location_url;
        /* e.g. ftp://nms.telecom_org.com/datastore/<fileName> */
    };

    typedef unsigned long FileSize; //the unit is byte
    typedef string FileCompression;
    typedef string FileFormat;

    struct FileInfo
    {
        FileLocation file_location;
        FileSize file_size;
        UTCTime file_ready_time;
        UTCTime file_expiration_time;
        FileCompression file_compression;
        FileFormat file_format;
    };

    typedef sequence<FileInfo> FileInfoList;

    const short PM_MANAGEMENT_DATA_TYPE = 1; //Performance Management
    const short CM_MANAGEMENT_DATA_TYPE = 2; //Configuration Management
    const short IM_MANAGEMENT_DATA_TYPE = 3; //Inventory Management
    const short TM_MANAGEMENT_DATA_TYPE = 4; //Test Management
    const short CT_MANAGEMENT_DATA_TYPE = 5; //Subscriber & Equipment Trace
    const short NL_MANAGEMENT_DATA_TYPE = 6; //Notification Log
    const short CG_MANAGEMENT_DATA_TYPE = 7; //Charging
    const short OT_MANAGEMENT_DATA_TYPE = 8; //Other Types

    /*
    Define the parameters specified in the notifyFileReady
    and notifyFilePreparationError notifications.
    */
    interface AttributeNameValue
    {
        const string FILE_INFO_LIST = "FILE_INFO_LIST";
        const string ADDITIONAL_TEXT = "ADDITIONAL_TEXT";
        const string REASON = "REASON";
    };
};

#endif // _FILE_TRANSFER_IRP_CONST_DEFS_IDL_

```

A.3.3 IDL specification "FileTransferIRPSystem.idl"

```

//File: FileTransferIRPSystem.idl
#ifndef _FILE_TRANSFER_IRP_SYSTEM_IDL_
#define _FILE_TRANSFER_IRP_SYSTEM_IDL_

#include <ManagedGenericIRPConstDefs.idl>
#include <ManagedGenericIRPSystem.idl>
#include <FileTransferIRPConstDefs.idl>

// This statement must appear after all include statements
#pragma prefix "3gppsa5.org"

/* ## Module: FileTransferIRPSystem
This module implements capabilities of FileTransferIRP.
=====
*/
module FileTransferIRPSystem
{
    exception InvalidTimes { string reason; };
    exception InvalidFileInfoList { string reason; };

    /*
    System fails to complete the operation. System can provide reason
    to qualify the exception. The semantics carried in reason
    is outside the scope of this IRP.
    */
    exception ListAvailableFiles { string reason; };
    exception FileDownloadIndication { string reason; };
    exception GetFileTransferIRPVersions { string reason; };
    exception GetFileTransferIRPOperationsProfile { string reason; };
    exception GetFileTransferIRPNotificationsProfile { string reason; };

    interface FileTransferIRP
    {
        /*
        * IRPManager invoke this operation to get the files information
        */
        FileTransferIRPConstDefs::Result list_available_files(
            in short management_data_type,
            in FileTransferIRPConstDefs::UTCTime begin_time,
            in FileTransferIRPConstDefs::UTCTime end_time,
            out FileTransferIRPConstDefs::FileInfoList file_info_list
        )
        raises (ListAvailableFiles, InvalidTimes,
            ManagedGenericIRPSystem::InvalidParameter);

        /*
        * IRPManager invoke this operation to indicate completion of downloading files to IRPAgent
        */
        FileTransferIRPConstDefs::Result file_download_indication(
            in FileTransferIRPConstDefs::FileInfoList file_info_list
        )
        raises (FileDownloadIndication, InvalidFileInfoList,
            ManagedGenericIRPSystem::OperationNotSupported);

        /**
        * Return the list of all supported FileTransferIRP versions.
        */
        ManagedGenericIRPConstDefs::VersionNumberSet get_file_transfer_irp_versions (
        )
        raises (GetFileTransferIRPVersions);

        /**
        * Return the list of all supported operations and their supported
        * parameters for a specific FileTransferIRP version.
        */
        ManagedGenericIRPConstDefs::MethodList get_file_transfer_irp_operations_profile (
            in ManagedGenericIRPConstDefs::VersionNumber irp_version
        )
        raises (GetFileTransferIRPOperationsProfile,
            ManagedGenericIRPSystem::OperationNotSupported,
            ManagedGenericIRPSystem::InvalidParameter);

        /**
        * Return the list of all supported notifications and their supported
        * parameters for a specific FileTransferIRP version.
        */
    }
}

```

```

*/
ManagedGenericIRPConstDefs::MethodList get_file_transfer_irp_notifications_profile
(
    in ManagedGenericIRPConstDefs::VersionNumber irp_version
)
raises (GetFileTransferIRPNotificationsProfile,
        ManagedGenericIRPSystem::OperationNotSupported,
        ManagedGenericIRPSystem::InvalidParameter);
};

};

#endif // _FILE_TRANSFER_IRP_SYSTEM_IDL_

```

A.3.4 IDL specification "FileTransferIRPNotifications.idl"

```

//File: FileTransferIRPNotifications.idl
#ifndef _FILE_TRANSFER_IRP_NOTIFICATIONS_IDL_
#define _FILE_TRANSFER_IRP_NOTIFICATIONS_IDL_

#include <FileTransferIRPConstDefs.idl>
#include <NotificationIRPNotifications.idl>

// This statement must appear after all include statements
#pragma prefix "3gppsa5.org"

/* ## Module: FileTransferIRPNotifications
This contains the specification of notifications of FileTransferIRP.
=====
*/
module FileTransferIRPNotifications
{
    /**
    * Constant definitions for the FileReady notification
    */
    interface NotifyFileReady: NotificationIRPNotifications::Notify
    {
        const string EVENT_TYPE = "notifyFileReady";

        /**
        * This constant defines the name of the fileInfoList property,
        * which is transported in the filterable_body fields.
        * The data type for the value of this property is
        * FileTransferIRPConstDefs::FileInfoList.
        */
        const string FILE_INFO_LIST =
            FileTransferIRPConstDefs::AttributeNameValue::FILE_INFO_LIST;

        /**
        * This constant defines the name of the additionalText property,
        * which is transported in the filterable_body fields.
        * The data type for the value of this property is string.
        */
        const string ADDITIONAL_TEXT =
            FileTransferIRPConstDefs::AttributeNameValue::ADDITIONAL_TEXT;
    };

    /**
    * Constant definitions for the FilePreparationError notification
    */
    interface NotifyFilePreparationError:
        NotificationIRPNotifications::Notify
    {
        const string EVENT_TYPE = "notifyFilePreparationError";

        /**
        * This constant defines the name of the fileInfoList property,
        * which is transported in the filterable_body fields.
        * The data type for the value of this property is
        * FileTransferIRPConstDefs::FileInfoList.
        */
        const string FILE_INFO_LIST =
            FileTransferIRPConstDefs::AttributeNameValue::FILE_INFO_LIST;
    };
};

```



```
/**
 * This constant defines the name of the reason property,
 * which is transported in the filterable_body fields.
 * The data type for the value of this property is string.
 */
const string REASON =
    FileTransferIRPConstDefs::AttributeNameValue::REASON;

/**
 * This constant defines the name of the additionalText property,
 * which is transported in the filterable_body fields.
 * The data type for the value of this property is string.
 */
const string ADDITIONAL_TEXT =
    FileTransferIRPConstDefs::AttributeNameValue::ADDITIONAL_TEXT;
};

};

#endif // _FILE_TRANSFER_IRP_NOTIFICATIONS_IDL_
```

Annex B (normative): XML Definitions

This annex contains the XML Definitions for the File Transfer Integration Reference Point (FT IRP) as it applies to Itf-N, in accordance with FT IRP IS definitions [15] as well as Notification Log IRP XML Definitions [16].

Apart from being used for the Notification Log, the XML definitions for FT IRP notifications are also used by the FT IRP SOAP SS.

B.1 Architectural Features

The overall architectural feature of FT IRP is specified in 3G TS 32.342 [15]. This clause specifies features that are specific to the XML definitions.

B.1.1 Syntax for Distinguished Names

The syntax of a Distinguished Name is defined in 3GPP TS 32.300 [6].

B.1.2 Notification Services

This annex defines the XML syntax of FT IRP notifications that is to be used for the FT IRP SOAP Solution Set and in conjunction with Notification Log IRP XML Definitions for Notification Log IRP XML Data File and the NL IRP XML Notification Format [16].

B.1.3 IOC Definitions

This annex defines the XML syntax for the IOC definitions of the FT IRP IS [15], which are used by the XML definitions for the FT IRP notifications and the FT IRP IS operations.

B.2 Mapping

Not present in the current version of this specification.

B.3 Solution Set definitions

B.3.1 XML definition structure

Clause B.3.2 provides a graphical representation of the XML elements.

Clause B.3.3 provides XML definitions of FT IRP notifications as defined in [15]. These definitions are to be used for the FT IRP SOAP Solution Set and in conjunction with Notification Log IRP XML Definitions for Notification Log IRP XML Data File and the NL IRP XML Notification Format [16], as well as considerations for NL IRP XML File Name Conventions defined therein.

Clause B.3.4 provides XML definitions of FT IOC as defined in [15].

B.3.2 Graphical Representation

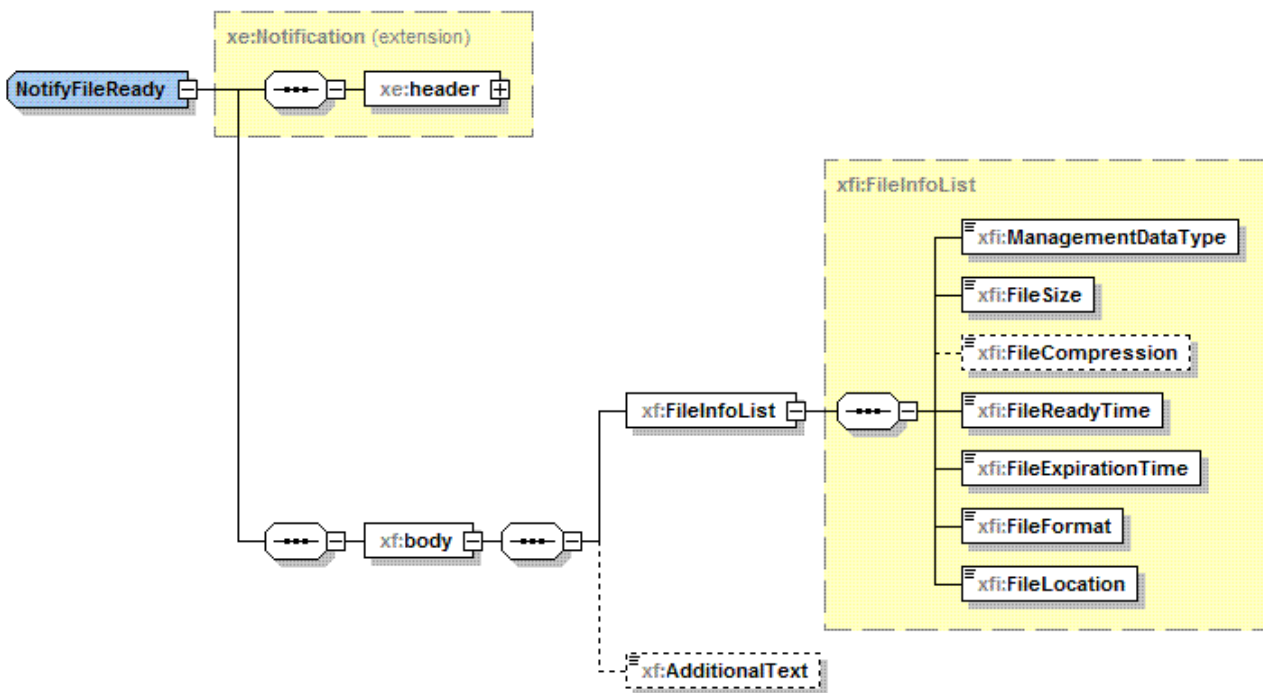

Figure B.3.2.1

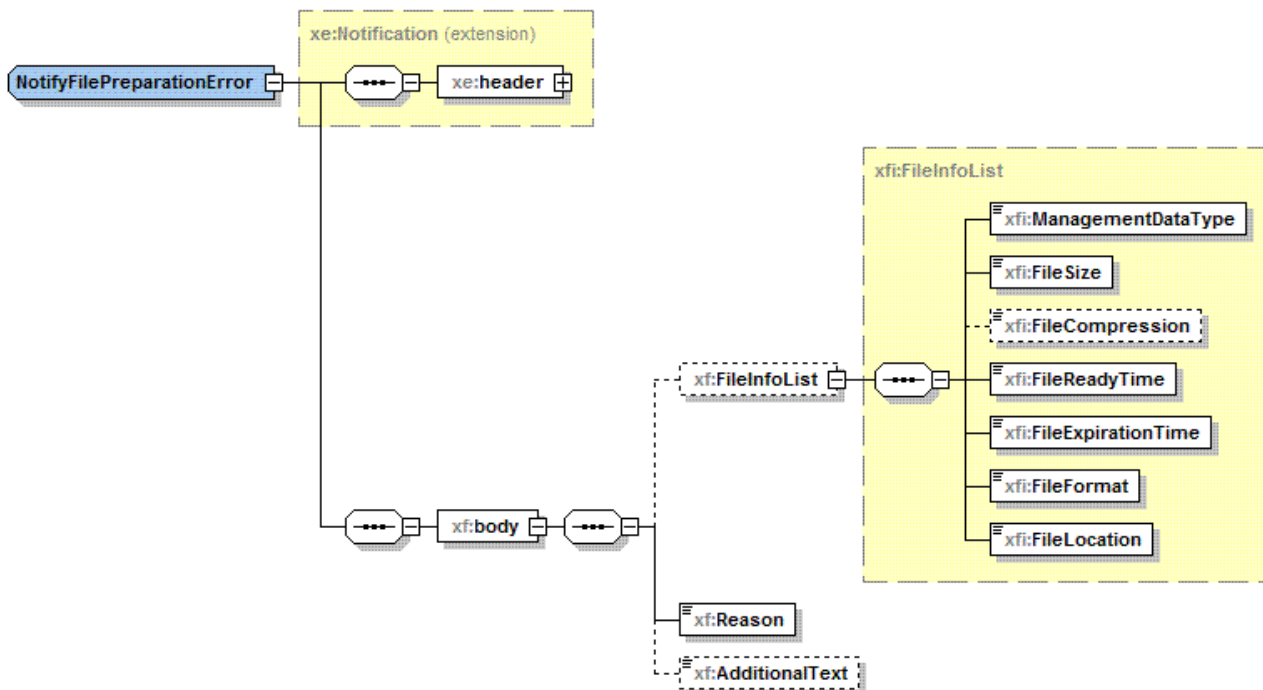

Figure B.3.2.2

NOTE: The use of XML schema key word "sequence" to support IS-defined set (not sequence) is for the purpose of XML processor efficiency. This shall not imply the use of "sequence" in other technology.

B.3.3 XML Schema 'ftIRPNotif.xsd'

```
<?xml version="1.0" encoding="UTF-8"?>
<!--
  3GPP TS 32.346 FTIRP Notification XML Schema
```

```

    FTIRPNotif.xsd
-->
<schema xmlns:xf="http://www.3gpp.org/ftp/specs/archive/32_series/32.346#fTIRPNotif"
xmlns:xfi="http://www.3gpp.org/ftp/specs/archive/32_series/32.346#fTIRPIOCs"
xmlns:xe="http://www.3gpp.org/ftp/specs/archive/32_series/32.306#notification"
xmlns="http://www.w3.org/2001/XMLSchema"
targetNamespace="http://www.3gpp.org/ftp/specs/archive/32_series/32.346#fTIRPNotif"
elementFormDefault="qualified" attributeFormDefault="unqualified">
  <import namespace="http://www.3gpp.org/ftp/specs/archive/32_series/32.346#fTIRPIOCs"/>
  <import namespace="http://www.3gpp.org/ftp/specs/archive/32_series/32.306#notification"/>
  <simpleType name="Reason">
    <restriction base="string">
      <enumeration value="errorInPreparation"/>
      <enumeration value="hardDiskFull"/>
      <enumeration value="hardDiskFailure"/>
      <enumeration value="tooManyFiles"/>
      <enumeration value="collectionTimeOut"/>
      <enumeration value="incompleteTruncatedFile"/>
      <enumeration value="corruptedFile"/>
      <enumeration value="lowMemory"/>
      <enumeration value="dataNotAvailable"/>
    </restriction>
  </simpleType>
  <complexType name="NotifyFileReady">
    <complexContent>
      <extension base="xe:Notification">
        <sequence>
          <element name="body">
            <complexType>
              <sequence>
                <element name="FileInfoList" type="xfi:FileInfoList" maxOccurs="unbounded"/>
                <element name="AdditionalText" type="string" minOccurs="0"/>
              </sequence>
            </complexType>
          </element>
        </sequence>
      </extension>
    </complexContent>
  </complexType>
  <complexType name="NotifyFilePreparationError">
    <complexContent>
      <extension base="xe:Notification">
        <sequence>
          <element name="body">
            <complexType>
              <sequence>
                <element name="FileInfoList" type="xfi:FileInfoList" minOccurs="0"/>
                <element name="Reason" type="xf:Reason"/>
                <element name="AdditionalText" type="string" minOccurs="0"/>
              </sequence>
            </complexType>
          </element>
        </sequence>
      </extension>
    </complexContent>
  </complexType>
  <element name="NotifyFileReady" type="xf:NotifyFileReady"/>
  <element name="NotifyFilePreparationError" type="xf:NotifyFilePreparationError"/>
</schema>

```

B.3.4 XML Schema 'fTIRPIOCs.xsd'

```

<?xml version="1.0" encoding="UTF-8"?>
<!--
  3GPP TS 32.346 FTIRP Notification XML Schema
  fTIRPIOCs.xsd
-->
<schema xmlns:xfi="http://www.3gpp.org/ftp/specs/archive/32_series/32.346#fTIRPIOCs"
xmlns:xe="http://www.3gpp.org/ftp/specs/archive/32_series/32.306#notification"
xmlns="http://www.w3.org/2001/XMLSchema"
targetNamespace="http://www.3gpp.org/ftp/specs/archive/32_series/32.346#fTIRPIOCs"
elementFormDefault="qualified" attributeFormDefault="unqualified">
  <simpleType name="FileFormat">
    <restriction base="string">
      <enumeration value="ASN1"/>
      <enumeration value="XML-schema"/>
    </restriction>

```

```
</simpleType>
<simpleType name="ManagementDataType">
  <restriction base="string">
    <enumeration value="CG"/>
    <enumeration value="CM"/>
    <enumeration value="CT"/>
    <enumeration value="IM"/>
    <enumeration value="NL"/>
    <enumeration value="OT"/>
    <enumeration value="PM"/>
    <enumeration value="TE"/>
  </restriction>
</simpleType>
<complexType name="FileInfoList">
  <sequence>
    <element name="ManagementDataType" type="xfi:ManagementDataType"/>
    <element name="FileSize" type="unsignedLong"/>
    <element name="FileCompression" type="string" minOccurs="0"/>
    <element name="FileReadyTime" type="dateTime"/>
    <element name="FileExpirationTime" type="dateTime"/>
    <element name="FileFormat" type="xfi:FileFormat"/>
    <element name="FileLocation" type="string"/>
  </sequence>
</complexType>
<!-- Attributes of the AvailableFileDescriptor IOC -->
<element name="managementDataType" type="xfi:ManagementDataType"/>
<element name="fileSize" type="unsignedLong"/>
<element name="fileCompression" type="string"/>
<element name="fileReadyTime" type="dateTime"/>
<element name="fileExpirationTime" type="dateTime"/>
<element name="fileFormat" type="xfi:FileFormat"/>
<element name="fileLocation" type="string"/>
</schema>
```

Annex C (normative): SOAP Solution Set

This annex specifies the SOAP Solution Set for the IRP whose semantics are specified in FT IRP: Information Service (3GPP TS 32.342 [15]).

C.1 Architectural features

The overall architectural feature of the FT IRP is specified in 3GPP TS 32.342 [15]. This clause specifies features that are specific to the SOAP Solution Set.

C.1.1 Syntax for Distinguished Names

The syntax of a Distinguished Name is defined in 3GPP TS 32.300 [6].

C.1.2 Notification Services

The FT IRP SOAP SS uses the Notification IRP SOAP SS of 3GPP TS 32.336 [16]. The IRPAgent shall support the push interface model, which means that the IRPAgent sends FT notifications to the IRPManager as soon as new events occur. The IRPManager does not need to check ("pull") for events.

Relevant definitions are imported from the FT IRP XML definitions in Annex B.

C.1.3 Supported W3C specifications

The SOAP 1.1 specification [11] and WSDL 1.1 specification [13] are supported.

The SOAP 1.2 specification [14] is supported optionally.

This specification uses "document" style in WSDL file.

This specification uses "literal" encoding style in WSDL file.

The filter language used in the SS is the XPath Language (see W3C XPath 1.0 specification [12]). IRPAgents may throw a FilterComplexityLimit fault when a given filter is too complex.

The FT IRP SOAP SS uses the Notification IRP SOAP SS of 3GPP TS 32.336 [5]. The IRPAgent shall support the push interface model, which means that the IRPAgent sends FT notifications to the IRPManager as soon as new events occur. The IRPManager does not need to check ("pull") for events.

C.1.4 Prefixes and namespaces

This specification uses a number of namespace prefixes throughout that are listed in Table C.1.4.

Table C.1.4: Prefixes and Namespaces used in this specification

PREFIX	NAMESPACE
(no prefix)	http://schemas.xmlsoap.org/wsdl/
soap	http://schemas.xmlsoap.org/wsdl/soap/
fTIRPSystem	http://www.3gpp.org/ftp/specs/archive/32_series/32.346#FTIRPSystem
fTIRPData	http://www.3gpp.org/ftp/specs/archive/32_series/32.346#FTIRPData
xfi	http://www.3gpp.org/ftp/specs/archive/32_series/32.346#FTIRPIOCs
genericIRPSystem	http://www.3gpp.org/ftp/specs/archive/32_series/32.316#GenericIRPSystem
ntfIRPNtfSystem	http://www.3gpp.org/ftp/specs/archive/32_series/32.306#NotificationIRPNtfSystem

C.2 Mapping

C.2.1 Operation and notification mapping

The FT IRP IS (3GPP TS 32.342 [15]) defines the operations and their semantics.

Table C.2.1 maps the operations defined in the FT IRP IS to their equivalent port type and binding operations in this Solution Set (SS).

Table C.2.1 also maps the notifications of the FT IRP IS, as well as inherited operations.

Table C.2.1 also qualifies if an operation is Mandatory (M) or Optional (O).

Table C.2.1: Mapping from IS Operation to SS Equivalents

IS Operation in 3GPP TS 32.342 [15]	SS: Operation for WSDL port type and WSDL binding	SS: Port of FileTransferIRPService	Qualifier
listAvailableFiles	listAvailableFiles (note 1)	FileTransferIRPPort	M
fileDownloadIndication	fileDownloadIndication (note 1)	FileTransferIRPPort	O
notifyFileReady	notify (note 2)	NotificationIRPNtfPort	M
notifyFilePreparationError	notify (note 2)	NotificationIRPNtfPort	M
getIRPVersion (note 3)	See TS 32.316 [8]	GenericIRPPort	M
getOperationProfile (note 3)	See TS 32.316 [8]	GenericIRPPort	O
getNotificationProfile (note 3)	See TS 32.316 [8]	GenericIRPPort	O
NOTE 1: The operation is under the port type ftIRPSystem:FileTransferIRPPortType and under the binding ftIRPSystem:FileTransferIRPBinding.			
NOTE 2: The IS equivalent maps to an XML definition defined in Annex B, and this being an input parameter to the operation notify under the port type ntfIRPNtfSystem:NotificationIRPNtf and under the binding ntfIRPNtfSystem:NotificationIRPNtf of 3GPP TS 32.306 [5]. This binding is linked to a port of the FileTransferIRPService as indicated in the table above.			
NOTE 3: The IS operation is inherited from the ManagedGenericIRP IOC specified in 3GPP TS 32.312 [7]. This inheritance is by the FileTransferIRP IOC of 3GPP TS 32.342 [15] inheriting from the ManagedGenericIRP IOC. The corresponding binding is linked to a port of the FileTransferIRPService as indicated in the table above.			

C.2.2 Operation parameter mapping

The FT IRP IS (3GPP TS 32.342 [15]) defines semantics of parameters carried in the operations. The tables below show the mapping of these parameters, as per operation, to their equivalents defined in this SS.

C.2.2.1 Operation listAvailableFiles

C.2.2.1.1 Input parameters

Table C.2.2.1.1: Mapping from IS listAvailableFiles input parameters to SS equivalents

IS Operation parameter	SS WSDL type sub-element used in corresponding input message under corresponding port type operation as indicated in Table 5.1	Qualifier
managementDataType	managementDataType	M
beginTime	beginTime	M
endTime	endTime	M

C.2.2.1.2 Output parameters

Table C.2.2.1.2: Mapping from IS `listAvailableFiles` output parameters to SS equivalents

IS Operation parameter	SS WSDL type sub-element used in corresponding output message under corresponding port type operation as indicated in Table 5.1	Qualifier
<code>fileInfoList</code>	<code>fileInfoList</code>	M
<code>status</code>	<code>status</code>	M

C.2.2.1.3 Fault definition

Table C.2.2.1.3: Mapping from IS `listAvailableFiles` exceptions to SS equivalents

Assertion name	SS WSDL type enumeration value used in corresponding fault message under corresponding port type operation as indicated in Table 5.1	Qualifier
<code>invalidTimes</code>	<code>InvalidTimes</code>	M

C.2.2.2 Operation `fileDownloadIndication`

C.2.2.2.1 Input parameters

Table C.2.2.2.1: Mapping from IS `fileDownloadIndication` input parameters to SS equivalents

IS Operation parameter	SS WSDL type sub-element used in corresponding input message under corresponding port type operation as indicated in Table 5.1	Qualifier
<code>fileInfoList</code>	<code>fileInfoList</code>	M

C.2.2.2.2 Output parameters

Table C.2.2.2.2: Mapping from IS `fileDownloadIndication` output parameters to SS equivalents

IS Operation parameter	SS WSDL type sub-element used in corresponding output message under corresponding port type operation as indicated in Table 5.1	Qualifier
<code>status</code>	<code>status</code>	M

C.2.2.2.3 Fault definition

Table C.2.2.2.3: Mapping from IS `fileDownloadIndication` exceptions to SS equivalents

Assertion name	SS WSDL type enumeration value used in corresponding fault message under corresponding port type operation as indicated in Table 5.1	Qualifier
<code>InvalidFileInfoList</code>	<code>InvalidFileInfoList</code>	M

C.3 Solution Set definitions

C.3.1 WSDL definition structure

Clause C.3.2 provides a graphical representation of the FT IRP service.

Clause C.3.3 defines the services which are supported the FT IRP agent.

C.3.2 Graphical Representation

The WSDL structure is depicted in Figure C.3.2 below, depicting port type, binding and service. The port type contains port type operations, which again contains input, output and fault messages. The binding contains binding operations, which have the same name as the port type operations. The binding connects to a port inside the service.

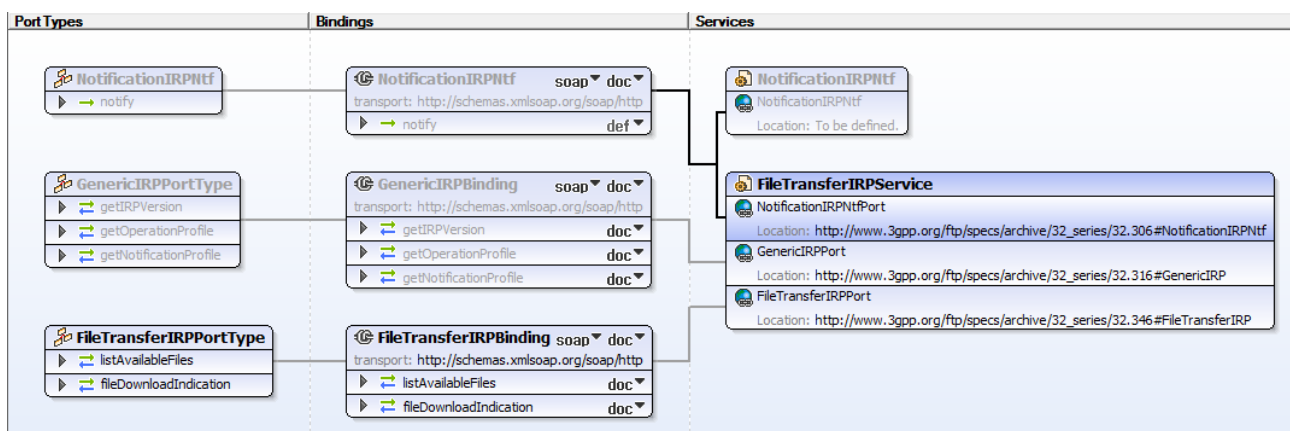

Figure C.3.2: File Transfer IRP SOAP Solution Set WSDL structure

C.3.3 WSDL specification 'FTRPSYSTEM.wsdl'

```
<?xml version="1.0" encoding="UTF-8"?>
<!--
  3GPP TS 32.346 File Transfer (FT) IRP SOAP Solution Set
-->
<definitions xmlns="http://schemas.xmlsoap.org/wsdl/"
  xmlns:soap="http://schemas.xmlsoap.org/wsdl/soap/"
  xmlns:fTIRPSYSTEM="http://www.3gpp.org/ftp/specs/archive/32_series/32.346#FTIRPSYSTEM"
  xmlns:fTIRPData="http://www.3gpp.org/ftp/specs/archive/32_series/32.346#FTIRPData"
  xmlns:xfi="http://www.3gpp.org/ftp/specs/archive/32_series/32.346#FTIRPIOCs"
  xmlns:genericIRPSYSTEM="http://www.3gpp.org/ftp/specs/archive/32_series/32.316#GenericIRPSYSTEM"
  xmlns:ntfIRPNtfSYSTEM="http://www.3gpp.org/ftp/specs/archive/32_series/32.306#NotificationIRPNtfSystem"
  targetNamespace="http://www.3gpp.org/ftp/specs/archive/32_series/32.346#FTIRPSYSTEM">
  <import
    namespace="http://www.3gpp.org/ftp/specs/archive/32_series/32.306#NotificationIRPNtfSystem"/>
  <import namespace="http://www.3gpp.org/ftp/specs/archive/32_series/32.316#GenericIRPSYSTEM"/>
  <types>
    <schema targetNamespace="http://www.3gpp.org/ftp/specs/archive/32_series/32.346#FTIRPData"
      xmlns="http://www.w3.org/2001/XMLSchema">
      <import namespace="http://www.3gpp.org/ftp/specs/archive/32_series/32.346#FTIRPIOCs"/>
      <!-- The following types are defined for the File Transfer IRP operations -->
      <simpleType name="OperationStatusTwo">
        <restriction base="string">
          <enumeration value="OperationSucceeded"/>
          <enumeration value="OperationFailed"/>
        </restriction>
      </simpleType>
      <complexType name="FileInfo">
        <sequence>
          <element ref="xfi:fileLocation"/>
          <element ref="xfi:fileSize"/>
          <element ref="xfi:fileReadyTime"/>
          <element ref="xfi:fileExpirationTime"/>
          <element ref="xfi:fileCompression"/>
          <element ref="xfi:fileFormat"/>
        </sequence>
      </complexType>
    </types>
  </definitions>
```

```

    <complexType name="FileInfoList">
      <sequence>
        <element name="fileInfo" type="fTIRPData:FileInfo" minOccurs="0"
maxOccurs="unbounded"/>
      </sequence>
    </complexType>
    <!-- listAvailableFiles Request-->
    <element name="listAvailableFiles">
      <complexType>
        <sequence>
          <element ref="xfi:managementDataType"/>
          <element name="beginTime" type="dateTime" minOccurs="0"/>
          <element name="endTime" type="dateTime" minOccurs="0"/>
        </sequence>
      </complexType>
    </element>
    <!-- listAvailableFiles Response -->
    <element name="listAvailableFilesResponse">
      <complexType>
        <sequence>
          <element name="fileInfoList" type="fTIRPData:FileInfoList"/>
          <element name="status" type="fTIRPData:OperationStatusTwo"/>
        </sequence>
      </complexType>
    </element>
    <!-- listAvailableFiles Fault -->
    <element name="listAvailableFilesFault">
      <simpleType>
        <restriction base="string">
          <enumeration value="InvalidTimes"/>
        </restriction>
      </simpleType>
    </element>
    <!-- fileDownloadIndication Request-->
    <element name="fileDownloadIndication">
      <complexType>
        <sequence>
          <element name="fileInfoList" type="fTIRPData:FileInfoList"/>
        </sequence>
      </complexType>
    </element>
    <!-- fileDownloadIndication Response -->
    <element name="fileDownloadIndicationResponse">
      <complexType>
        <sequence>
          <element name="status" type="fTIRPData:OperationStatusTwo"/>
        </sequence>
      </complexType>
    </element>
    <!-- fileDownloadIndication Fault -->
    <element name="fileDownloadIndicationFault">
      <simpleType>
        <restriction base="string">
          <enumeration value="InvalidFileInfoList"/>
        </restriction>
      </simpleType>
    </element>
  </schema>
</types>
<message name="listAvailableFiles">
  <part name="parameter" element="fTIRPData:listAvailableFiles"/>
</message>
<message name="listAvailableFilesResponse">
  <part name="parameter" element="fTIRPData:listAvailableFilesResponse"/>
</message>
<message name="listAvailableFilesFault">
  <part name="parameter" element="fTIRPData:listAvailableFilesFault"/>
</message>
<message name="fileDownloadIndication">
  <part name="parameter" element="fTIRPData:fileDownloadIndication"/>
</message>
<message name="fileDownloadIndicationResponse">
  <part name="parameter" element="fTIRPData:fileDownloadIndicationResponse"/>
</message>
<message name="fileDownloadIndicationFault">
  <part name="parameter" element="fTIRPData:fileDownloadIndicationFault"/>
</message>
<portType name="FileTransferIRPPortType">
  <operation name="listAvailableFiles">
    <input message="fTIRPSystem:listAvailableFiles"/>
    <output message="fTIRPSystem:listAvailableFilesResponse"/>
    <fault name="listAvailableFilesFault" message="fTIRPSystem:listAvailableFilesFault"/>
  </operation>
  <operation name="fileDownloadIndication">
    <input message="fTIRPSystem:fileDownloadIndication"/>
    <output message="fTIRPSystem:fileDownloadIndicationResponse"/>
    <fault name="fileDownloadIndicationFault"
message="fTIRPSystem:fileDownloadIndicationFault"/>
  </operation>

```

```

</portType>
<binding name="FileTransferIRPBinding" type="ftIRPSystem:FileTransferIRPPortType">
  <soap:binding style="document" transport="http://schemas.xmlsoap.org/soap/http"/>
  <operation name="listAvailableFiles">
    <soap:operation
soapAction="http://www.3gpp.org/ftp/specs/archive/32_series/32.346#listAvailableFiles"
style="document"/>
    <input>
      <soap:body use="literal"/>
    </input>
    <output>
      <soap:body use="literal"/>
    </output>
    <fault name="listAvailableFilesFault">
      <soap:fault name="listAvailableFilesFault" use="literal"/>
    </fault>
  </operation>
  <operation name="fileDownloadIndication">
    <soap:operation
soapAction="http://www.3gpp.org/ftp/specs/archive/32_series/32.346#fileDownloadIndication"
style="document"/>
    <input>
      <soap:body use="literal"/>
    </input>
    <output>
      <soap:body use="literal"/>
    </output>
    <fault name="fileDownloadIndicationFault">
      <soap:fault name="fileDownloadIndicationFault" use="literal"/>
    </fault>
  </operation>
</binding>
<service name="FileTransferIRPService">
  <port name="FileTransferIRPPort" binding="ftIRPSystem:FileTransferIRPBinding">
    <soap:address
location="http://www.3gpp.org/ftp/specs/archive/32_series/32.346#FileTransferIRP"/>
  </port>
  <port name="GenericIRPPort" binding="genericIRPSystem:GenericIRPBinding">
    <soap:address
location="http://www.3gpp.org/ftp/specs/archive/32_series/32.316#GenericIRP"/>
  </port>
  <port name="NotificationIRPNtfPort" binding="ntfIRPNtfSystem:NotificationIRPNtf">
    <soap:address
location="http://www.3gpp.org/ftp/specs/archive/32_series/32.306#NotificationIRPNtf"/>
  </port>
</service>
</definitions>

```

Annex D (informative): Change history

Change history							
Date	TSG #	TSG Doc.	CR	Rev	Subject/Comment	Old	New
2010-09	SA#49	SP-100516	--	--	Presentation to SA for Information and Approval	---	1.0.0
2010-10	--	--	--	--	Publication	1.0.0	10.0.0
2012-09	SA#57	-	-	-	Automatic upgrade from previous Release version 10.0.0	10.0.0	11.0.0
2014-09	SA#65	SP-140559	001	-	Update the link from Solution Set to Information Service due to the end of Release 12	11.0.0	12.0.0

History

Document history		
V12.0.0	October 2014	Publication