

ETSI TS 132 442 V10.4.0 (2012-03)



Technical Specification

**Digital cellular telecommunications system (Phase 2+);
Universal Mobile Telecommunications System (UMTS);
LTE;
Telecommunication management;
Trace Management Integration Reference Point (IRP);
Information Service (IS)
(3GPP TS 32.442 version 10.4.0 Release 10)**



Reference

RTS/TSGS-0532442va40

Keywords

GSM,LTE,UMTS

ETSI

650 Route des Lucioles
F-06921 Sophia Antipolis Cedex - FRANCE

Tel.: +33 4 92 94 42 00 Fax: +33 4 93 65 47 16

Siret N° 348 623 562 00017 - NAF 742 C
Association à but non lucratif enregistrée à la
Sous-Préfecture de Grasse (06) N° 7803/88

Important notice

Individual copies of the present document can be downloaded from:

<http://www.etsi.org>

The present document may be made available in more than one electronic version or in print. In any case of existing or perceived difference in contents between such versions, the reference version is the Portable Document Format (PDF). In case of dispute, the reference shall be the printing on ETSI printers of the PDF version kept on a specific network drive within ETSI Secretariat.

Users of the present document should be aware that the document may be subject to revision or change of status. Information on the current status of this and other ETSI documents is available at

<http://portal.etsi.org/tb/status/status.asp>

If you find errors in the present document, please send your comment to one of the following services:

http://portal.etsi.org/chaicor/ETSI_support.asp

Copyright Notification

No part may be reproduced except as authorized by written permission.
The copyright and the foregoing restriction extend to reproduction in all media.

© European Telecommunications Standards Institute 2012.
All rights reserved.

DECT™, **PLUGTESTS™**, **UMTS™** and the ETSI logo are Trade Marks of ETSI registered for the benefit of its Members.
3GPP™ and **LTE™** are Trade Marks of ETSI registered for the benefit of its Members and of the 3GPP Organizational Partners.
GSM® and the GSM logo are Trade Marks registered and owned by the GSM Association.

Intellectual Property Rights

IPRs essential or potentially essential to the present document may have been declared to ETSI. The information pertaining to these essential IPRs, if any, is publicly available for **ETSI members and non-members**, and can be found in ETSI SR 000 314: *"Intellectual Property Rights (IPRs); Essential, or potentially Essential, IPRs notified to ETSI in respect of ETSI standards"*, which is available from the ETSI Secretariat. Latest updates are available on the ETSI Web server (<http://ipr.etsi.org>).

Pursuant to the ETSI IPR Policy, no investigation, including IPR searches, has been carried out by ETSI. No guarantee can be given as to the existence of other IPRs not referenced in ETSI SR 000 314 (or the updates on the ETSI Web server) which are, or may be, or may become, essential to the present document.

Foreword

This Technical Specification (TS) has been produced by ETSI 3rd Generation Partnership Project (3GPP).

The present document may refer to technical specifications or reports using their 3GPP identities, UMTS identities or GSM identities. These should be interpreted as being references to the corresponding ETSI deliverables.

The cross reference between GSM, UMTS, 3GPP and ETSI identities can be found under <http://webapp.etsi.org/key/queryform.asp>.

Contents

Intellectual Property Rights	2
Foreword.....	2
Foreword.....	5
Introduction	5
1 Scope	6
2 References	6
3 Definitions and abbreviations.....	6
3.1 Definitions	6
3.2 Abbreviations	7
4 System Overview	7
4.1 System context	7
4.2 Compliance rules.....	7
5 Information Object Classes	8
5.1 Imported information entities and local labels	8
5.2 Class diagram	8
5.2.1 Attributes and relationships	8
5.2.2 Inheritance	9
5.3 Information object class definitions	9
5.3.1 TraceJob.....	9
5.3.1.1 Definition	9
5.3.1.2 Attributes.....	11
5.3.1.3 Attribute constraints	11
5.3.2 TraceRecord.....	12
5.3.2.1 Definition.....	12
5.3.2.2 Attributes.....	12
5.3.3 TraceIRP	12
5.3.3.1 Definition	12
5.3.4 ManagedEntity.....	12
5.3.4.1 Definition	12
5.4 Information relationship definitions	13
5.4.1 relation-traceIRP-traceJob (M).....	13
5.4.1.1 Definition	13
5.4.1.2 Roles	13
5.4.2 relation-traceJob-managedEntity (M).....	13
5.4.2.1 Definition	13
5.4.2.2 Roles	13
5.4.3 relation-traceJob-traceRecord (M).....	14
5.4.3.1 Definition	14
5.4.3.2 Roles	14
5.5 Information attribute definitions.....	15
5.5.1 Definition and legal values	15
6 Interface Definition	17
6.1 Class diagram representing interfaces	17
6.2 Generic rules	17
6.3 TraceIRPManagement (M).....	18
6.3.1 Operation activateTraceJob (M).....	18
6.3.1.1 Definition	18
6.3.1.2 Input parameters.....	19
6.3.1.3 Output parameters	20
6.3.1.4 Pre-condition.....	20
6.3.1.5 Post-condition	21

6.3.1.6	Exceptions	21
6.3.1.7	Constraints	21
6.3.2	Operation deactivateTraceJob (M)	21
6.3.2.1	Definition	21
6.3.2.2	Input parameters	22
6.3.2.3	Output parameters	22
6.3.2.4	Pre-condition	22
6.3.2.4	Post-condition	22
6.3.2.6	Exceptions	22
6.3.3	Operation listTraceJob (M)	22
6.3.3.1	Definition	22
6.3.3.2	Input parameters	23
6.3.3.3	Output parameters	23
6.3.3.4	Pre-condition	23
6.3.3.5	Post-condition	24
6.3.3.6	Exceptions	24
6.3.3.7	Constraints	24
6.3.4	Operation listActivatedTraceJobs (M)	24
6.3.4.1	Definition	24
6.3.4.2	Input parameters	24
6.3.4.3	Output parameters	25
6.3.5	Notification notifyTraceRecordingSessionFailure (O)	25
6.3.5.1	Definition	25
6.3.5.2	Input parameters	25
6.3.5.3	Triggering event	25
6.3.5.3.1	From state	25
6.3.5.3.2	To state	25
6.3.6	Notification notifyTraceSessionLocalActivation (M)	26
6.3.6.1	Definition	26
6.3.6.2	Input parameters	26
6.3.6.3	Triggering event	26
6.3.6.3.1	From state	26
6.3.6.3.2	To state	26
6.3.7	Notification notifyTraceSessionIdentities (CM)	26
6.3.7.1	Definition	26
6.3.7.2	Input parameters	27
6.3.7.3	Triggering event	27
6.3.7.3.1	From state	27
6.3.7.3.2	To state	27
6.3.7.4	Constraint	27
Annex A (informative): Change history		28
History		29

Foreword

This Technical Specification has been produced by the 3rd Generation Partnership Project (3GPP).

The contents of the present document are subject to continuing work within the TSG and may change following formal TSG approval. Should the TSG modify the contents of the present document, it will be re-released by the TSG with an identifying change of release date and an increase in version number as follows:

Version x.y.z

where:

- x the first digit:
 - 1 presented to TSG for information;
 - 2 presented to TSG for approval;
 - 3 or greater indicates TSG approved document under change control.
- y the second digit is incremented for all changes of substance, i.e. technical enhancements, corrections, updates, etc.
- z the third digit is incremented when editorial only changes have been incorporated in the document.

Introduction

The present document is part of a TS-family covering the 3rd Generation Partnership Project; Technical Specification Group Services and System Aspects; Telecommunication management; as identified below:

- 32.441 "Trace Management Integration Reference Point (IRP): Requirements".
- 32.442 "Trace Management Integration Reference Point (IRP): Information Service (IS)".**
- 32.443 "Trace Management Integration Reference Point (IRP): Common Object Request Broker Architecture (CORBA) Solution Set (SS)".
- 32.445 "Trace Management Integration Reference Point (IRP): eXtensible Markup Language (XML) file format definition".

The present document is part of a TS-family which describes the information service necessary for the Telecommunication Management (TM) of 3G systems. The TM principles and TM architecture are specified in 3GPP TS 32.101 [1] and 3GPP TS 32.102 [2].

Trace provides very detailed information on call level for a specific subscriber or MS. This data is an additional information source to Performance Measurements and allows deeper investigations in problems solving or in case of optimization.

1 Scope

2 References

The following documents contain provisions which, through reference in this text, constitute provisions of the present document.

- References are either specific (identified by date of publication, edition number, version number, etc.) or non-specific.
- For a specific reference, subsequent revisions do not apply.
- For a non-specific reference, the latest version applies. In the case of a reference to a 3GPP document (including a GSM document), a non-specific reference implicitly refers to the latest version of that document *in the same Release as the present document*.

- [1] 3GPP TS 32.101: "Telecommunication management; Principles and high level requirements".
- [2] 3GPP TS 32.102: "Telecommunication management; Architecture".
- [3] 3GPP TS 32.150: "Telecommunication management; Integration Reference Point (IRP) Concept and definitions".
- [4] 3GPP TS 32.152: "Telecommunication management; Integration Reference Point (IRP) Information Service (IS) Unified Modelling Language (UML) repertoire".
- [5] 3GPP TS 32.622: "Telecommunication management; Configuration Management (CM); Generic network resources Integration Reference Point (IRP); Network Resource Model (NRM)".
- [6] 3GPP TS 32.302: "Telecommunication management; Configuration Management (CM); Notification Integration Reference Point (IRP): Information Service (IS)".
- [7] 3GPP TS 32.342: "Telecommunication management; File Transfer (FT) Integration Reference Point (IRP): Information Service (IS)".
- [8] 3GPP TS 32.312: "Telecommunication management; Generic Integration Reference Point (IRP) management: Information Service (IS)".
- [9] 3GPP TS 32.422: "Telecommunication management; Subscriber and equipment trace; Trace control and configuration management".
- [10] 3GPP TS 32.602: "Telecommunication management; Configuration Management (CM); Basic CM Integration Reference Point (IRP): Information Service (IS)".

3 Definitions and abbreviations

3.1 Definitions

For the purposes of the present document, the terms and definitions given in 3GPP TS 32.101 [1], 3GPP TS 32.102 [2], 3GPP TS 32.150 [3] and the following apply:

IRPAgent: See 3GPP TS 32.102 [2].

IRPManager: See 3GPP TS 32.102 [2].

3.2 Abbreviations

For the purposes of the present document, the abbreviations given in 3GPP TS 32.101 [1], 3GPP TS 32.102 [2], 3GPP TS 32.150 [3] and the following apply:

IOC	Information Object Class
IRP	Integration Reference Point
IS	Information Service
OMG	Object Management Group
UML	Unified Modelling Language (OMG)

4 System Overview

4.1 System context

The general definition of the System Context for the present IRP is found in 3GPP TS 32.150 [3] subclause 4.7.

In addition, the set of related IRP(s) relevant to the present IRP is shown in the two diagrams below.

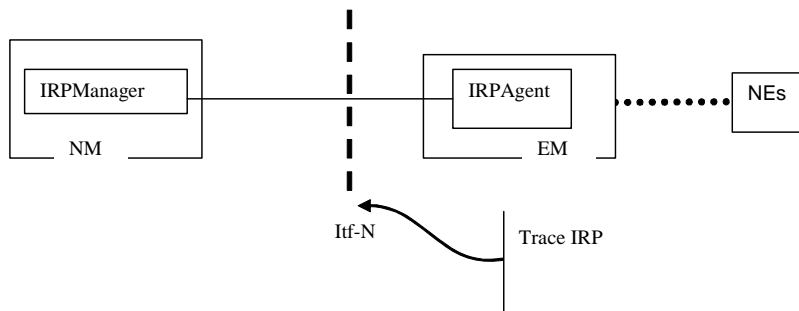

Figure 4.1.1: System Context A

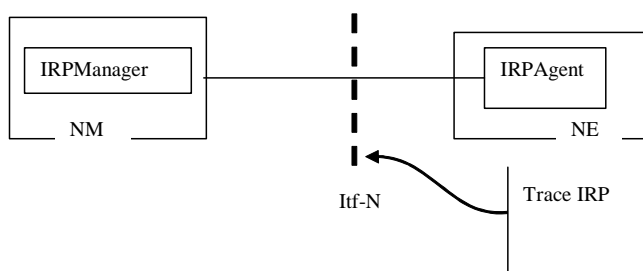

Figure 4.1.2: System Context B

4.2 Compliance rules

For general definitions of compliance rules related to qualifiers (Mandatory/Optional/Conditional) for *operations*, *notifications* and *parameters* (of operations and notifications) please refer to 3GPP TS 32.150 [3].

5 Information Object Classes

5.1 Imported information entities and local labels

Label reference	Local label
3GPP TS 32.622 [5], information object class, Top	Top
3GPP TS 32.622 [5], information object class, IRPAgent	IRPAgent
3GPP TS 32.622 [5], information object class, GenericIRP	GenericIRP
3GPP TS 32.302 [6], information object class, NotificationIRP	NotificationIRP
3GPP TS 32.342 [7], information object class, FileTransferIRP	FileTransferIRP
3GPP TS 32.602 [10], information object class, ManagedEntity	ManagedEntity

5.2 Class diagram

5.2.1 Attributes and relationships

This clause introduces the set of Information Object Classes (IOCs) that encapsulate information within the IRPAgent. The intent is to identify the information required for the TraceIRP implementation of its operations and notification emission. This clause provides the overview of all support object classes in UML. Subsequent clauses provide more detailed specification of various aspects of these support object classes.

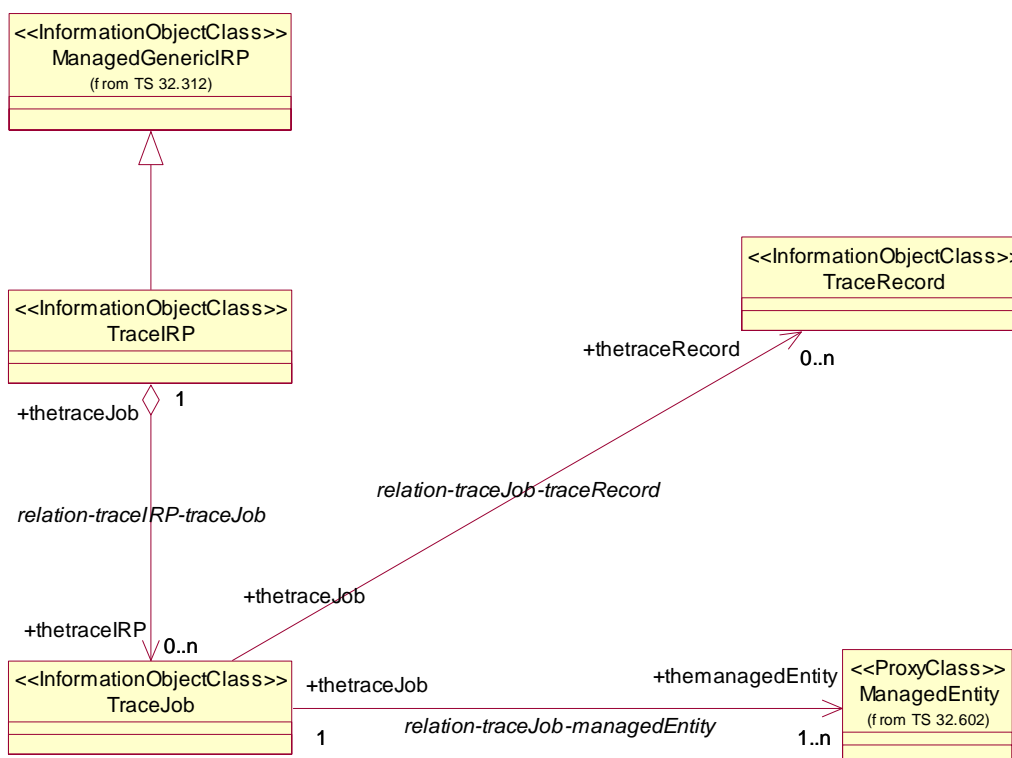

Figure 5.2.1: Information Object Class (IOC) UML diagram

5.2.2 Inheritance

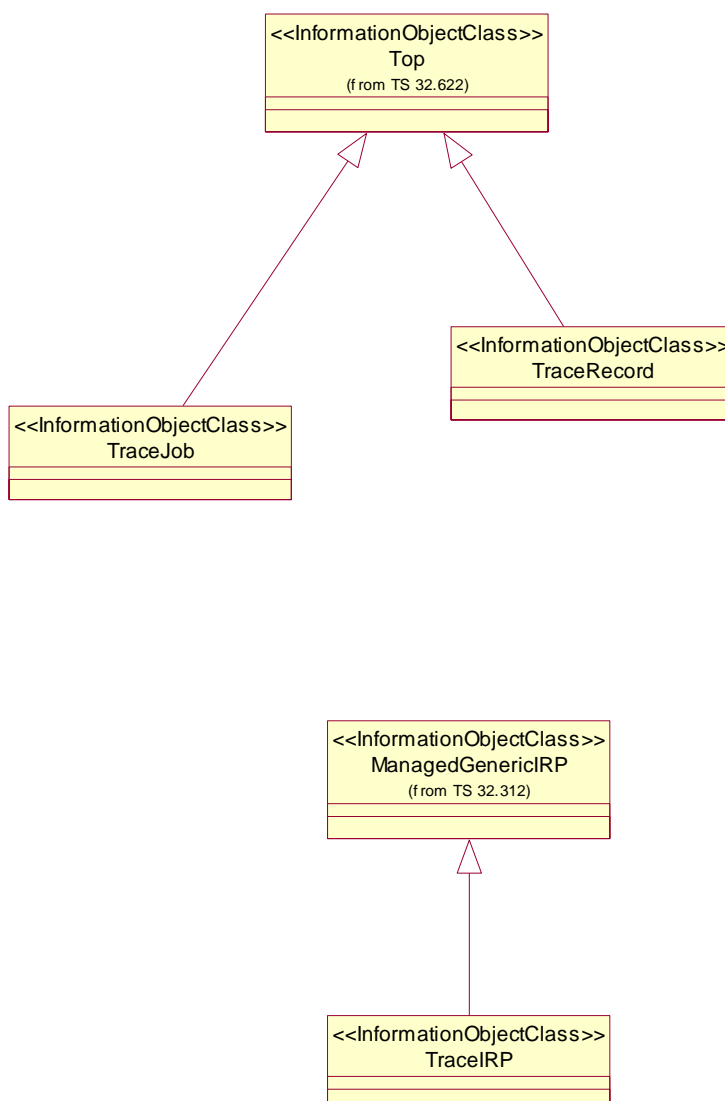

Figure 5.2.2: Information Object Class Inheritance UML Diagram

5.3 Information object class definitions

5.3.1 TraceJob

5.3.1.1 Definition

It represents a task that controls the Trace Sessions and collects the trace data (i.e. collects the `TraceRecord` of multiple `ManagedEntity` instances). The `TraceReference` is a unique ID, which identifies the Trace Session that has been created by the `TraceJob` and activated to one or multiple `ManagedEntity` instance(s).

It represents also the task that controls the UE based network performance measurements.

When a `TraceJob` is created the following attributes cannot be modified via the Itf-N:

- TraceReference
- ListOfInterfaces
- ListofNeTypes
- TraceDepth
- TraceTarget
- TriggeringEvent
- JobType
- MDTAreaScope
- ListOfMeasurements
- ReportingTrigger
- ReportInterval
- ReportAmount
- EventThreshold
- LoggingInterval
- LoggingDuration
- IPAddressOfTCE

If for any reason the TraceIRP determines that a Trace Session has been activated in its ManagedEntity(ies) the TraceIRP shall emit the "noitfyTraceSessionLocalActivation" notification to the subscribed IRPManagers to inform the active Trace Sessions. The IRPManagers can decide whether they deactivate the Trace Session or keep the Trace Session active. (E.g. if the TraceReference is colliding with an existing TraceJob"s TraceReference, the IRPManager may decide to immediately deactivate the Trace Session in that ManagedEntity.)

The TraceJob shall use its information to activate and configure Trace Session(s) in the requested ManagedEntity instance(s). When the TraceIRP determines that there are available TraceRecord files, it shall emit a notification to all subscribed IRPManagers informing the availability of the files. The method and the notification of the available files is described in the File Transfer IRP (3GPP TS 32.342 [7]).

If a TraceJob receives an indication from one of its ManagedEntity that starting a Trace Recording Session is failed for any reason, the "notifyTraceRecordingSessionFailure" notification may be emitted to inform all subscribed IRPManagers that there was a Trace Recording Session that was not started in the ManagedEntity.

5.3.1.2 Attributes

Attribute name	Support Qualifier
traceReference	M
listOfInterfaces	O
listOfNeTypes	CM
traceDepth	CM
traceTarget	M
triggeringEvent	CM
traceCollectionEntityAddress	M
jobType	M
listOfMeasurements	CM
reportingTrigger	CM
reportInterval	CM
reportAmount	CM
eventThreshold	CM
loggingInterval	CM
loggingDuration	CM
mdtAreaScope	CM

5.3.1.3 Attribute constraints

The `listOfNeTypes` attributes shall be present only for Signalling Based Activation.

The `traceTarget` shall be public ID in case of a Management Based Activation is done to an `ScscfFunction`.

The `TraceTarget` shall be `cell` only in case of the UTRAN cell traffic trace function.

The `TraceTarget` shall be `E-UtranCell` only in case of E-UTRAN cell traffic trace function. The `traceTarget` shall be either IMSI or IMEI(SV) if the Trace Session is activated to any of the following `ManagedEntity(ies)`:

- `HssFunction`
- `MscServerFunction`
- `SgsnFunction`
- `GgsnFunction`
- `BmscFunction`
- `RncFunction`
- `MmeFunction`

The `traceTarget` shall be IMSI if the Trace Session is activated to a `ManagedEntity` playing a role of `ServingGWFunction`.

In case of subscription based MDT, the `traceTarget` attribute shall be able to carry (IMSI or IMEI(SV)), the `mdtAreaScope` attribute shall be able to carry a list of (`cell` or `EUtranCell` or `TA/LA/RA`).

In case of area based Immediate MDT, the `traceTarget` attribute shall be null value, the `mdtAreaScope` attribute shall carry a list of (`Utrancell` or `E-UtranCell`).

In case of area based Logged MDT, the `traceTarget` attribute shall carry an `eNodeB` or a `RNC`. The Logged MDT should be initiated on the specified `eNodeB/RNC` in `TraceTarget`. The `mdtAreaScope` attribute shall carry a list of (`Utrancell` or `E-UtranCell` or `TA/LA/RA`).

- `traceTarget`: This attribute shall be present if Trace or subscription based MDT is supported.
- `mdtAreaScope`: This attribute shall be present if MDT is supported.
- `triggeringEvent`: This attribute shall be present only if Trace is supported.

- `listOfMeasurements`: This attribute shall be present only if MDT is supported and the `JobType` attribute is set to `ImmediateMDT`.
- `reportingTrigger`: This attribute shall be present only if MDT is supported and the `JobType` attribute is set to `ImmediateMDT` and the `ListOfMeasurements` attribute is configured for `M1`.
- `reportInterval`: This attribute shall be present only if MDT is supported and the `JobType` attribute is set to `ImmediateMDT` and the `ReportingTrigger` is configured for `PeriodicMeasurements`.
- `reportAmount`: This attribute shall be present only if MDT is supported and the `JobType` attribute is set to `ImmediateMDT` and the `ReportingTrigger` attribute is configured for `PeriodicMeasurements`.
- `eventThreshold`: This attribute shall be present only if MDT is supported and the `JobType` attribute is set to `ImmediateMDT` and the `ReportTrigger` attribute is configured for `A2EventReporting`.
- `loggingInterval`: This attribute shall be present only if MDT is supported and the `JobType` attribute is set to `LoggedMDT`.
- `loggingDuration`: This attribute shall be present only if MDT is supported and the `JobType` attribute is set to `LoggedMDT`.

5.3.2 TraceRecord

5.3.2.1 Definition

`TraceRecord` is the representation of the files containing the logged information from the Trace Recording Sessions.

5.3.2.2 Attributes

Attribute name	Visibility	Support Qualifier	Read Qualifier	Write Qualifier
<code>fileName</code>	+	M	M	-

5.3.3 TraceIRP

5.3.3.1 Definition

`TraceIRP` is the representation of the trace management capabilities specified by the present document. This IOC inherits from `ManagedGenericIRP` IOC specified in 3GPP TS 32.312 [8].

5.3.4 ManagedEntity

5.3.4.1 Definition

In case of Signalling Based Activation the `ManagedEntity` represents the role that can be played by an instance of one of the following IOCs:

- `HssFunction`
- `MscServerFunction`
- `SgsnFunction`
- `MmeFunction`

In case of Management Based Activation the `ManagedEntity` represents the role that can be played by an instance of the following IOCs:

- HssFunction
- MscServerFunction
- SgsnFunction
- GgsnFunction
- BmscFunction
- RncFunction
- CscfFunction
- MmeFunction
- ServingGWFunction

In case of Cell Traffic Trace the ManagedEntity represents the role that can be played by an instance of the following IOCs:

- UtranCell
- E-UtranCell

5.4 Information relationship definitions

5.4.1 relation-traceIRP-traceJob (M)

5.4.1.1 Definition

This represents the relationship between TraceIRP and the TraceJob.

5.4.1.2 Roles

Name	Definition
theTraceIRP	It represents the TraceIRP
theTraceJobList	It represents the TraceJobList

5.4.2 relation-traceJob-managedEntity (M)

5.4.2.1 Definition

This represents the relationship between TraceJob and the ManagedEntity.

5.4.2.2 Roles

Name	Definition
theManagedEntity	The ManagedEntity, when playing this role, represents the actual network resource instance, where a Trace Session is activated.
theTraceJob	It represents the TraceJob

5.4.3 relation-traceJob-traceRecord (M)

5.4.3.1 Definition

This represents the relationship between TraceJob and the TraceRecord.

5.4.3.2 Roles

Name	Definition
theTraceJob	It represents the TraceJob
theTraceRecord	It represents the TraceRecord.

5.5 Information attribute definitions

5.5.1 Definition and legal values

Attribute Name	Definition	Legal Values
listOfInterfaces	It specifies the interfaces that needs to be traced in the given ManagedEntityFunction. The attribute is applicable only for Trace. In case this attribute is not used, it carries a nulls semantic.	See 3GPP TS 32.422 [9]
listOfNETypes	It specifies in which type of ManagedFunction the trace should be activated. The attribute is applicable only for Trace with Signalling Based Trace activation. In case this attribute is not used, it carries a nulls semantic.	See 3GPP TS 32.422 [9]
traceCollectionEntityAddress	It specifies the address of the Trace Collection Entity within an IRPManager. The attribute is applicable for for both Trace and MDT	See 3GPP TS 32.422 [9]
traceDepth	It specifies the trace depth of the ManagedEntityFunction instances. The attribute is applicable only for Trace. In case this attribute is not used, it carries a nulls semantic.	See 3GPP TS 32.422 [9]
traceReference	A globally unique identifier, which uniquely identifies the Trace Session that is created by the TraceJob. The attribute is applicable for both Trace and MDT.	Any positive integer value
traceTarget	It specifies the target object of the Trace and MDT. The attribute is applicable for both Trace and MDT.	IMSI or IMEI or IMEISV or Public ID or Private ID or a Cell (identified by its DN id) or an eNB or a RNC. IMSI, IMEI, IMEISV, Public ID, cell, eNB and RNC are mutually exclusive.
triggeringEvent	It specifies the triggering event parameter of the trace session. The attribute is applicable only for Trace. In case this attribute is not used, it carries a nulls semantic.	See 3GPP TS 32.422 [9]
jobType	It specifies the MDT mode and it specifies also whether the TraceJob represents only MDT, Trace or a combined Trace and MDT job. The attribute is applicable for both Trace and MDT.	See 3GPP TS 32.422 [9]
mdtAreaScope	It specifies MDT area scope when activates an MDT job.	List of cells/TA/LA/RA for subscription based MDT or area based Logged MDT. List of cells for area based Immediate MDT. Cell, TA, LA, RA are mutually exclusive.
listOfMeasurements	It specifies the UE measurements that shall be collected in an Immediate MDT job. The attribute is applicable only for Immediate MDT. In case this attribute is not used, it carries a nulls semantic.	See 3GPP TS 32.422 [9]
reportingTrigger	It specifies whether periodic or event based measurements should be collected. The attribute is applicable only for Immediate MDT and when the listOfMeasurements is configured for M1. In case this attribute is not used, it carries a nulls semantic.	See 3GPP TS 32.422 [9]
reportInterval	It specifies the interval between the periodical measurements that shall be taken when the UE is in connected mode. The attribute is applicable only for Immediate MDT and when reportingTrigger is configured for periodical measurements. In case this attribute is not used, it carries a nulls semantic.	See 3GPP TS 32.422 [9]
reportAmount	It specifies the number of measurement reports that shall be taken for periodic reporting while the UE is in connected. The attribute is applicable only for Immediate	See 3GPP TS 32.422 [9]

Attribute Name	Definition	Legal Values
	MDT and when reportingTrigger is configured for periodical measurements. In case this attribute is not used, it carries a nulls semantic.	
eventThreshold	It specifies the threshold which should trigger the reporting in case A2 event reporting. The attribute is applicable only for Immediate MDT and when reportingTrigger is configured for A2 event . In case this attribute is not used, it carries a nulls semantic.	See 3GPP TS 32.422 [9] and 3GPP TS 36.331 [y]
loggingInterval	It specifies the periodicty for logging MDT. The attribute is applicable only for Logged MDT. In case this attribute is not used, it carries a nulls semantic.	See 3GPP TS 32.422 [9], 3GPP TS 25.331 [] 3GPP TS 36.331 [y]
loggingDuration	It specifies how long the MDT configuration is valid at the UE in case of Logged MDT. The attribute is applicable only for Logged MDT. In case this attribute is not used, it carries a nulls semantic.	See 3GPP TS 32.422 [9]

6 Interface Definition

6.1 Class diagram representing interfaces

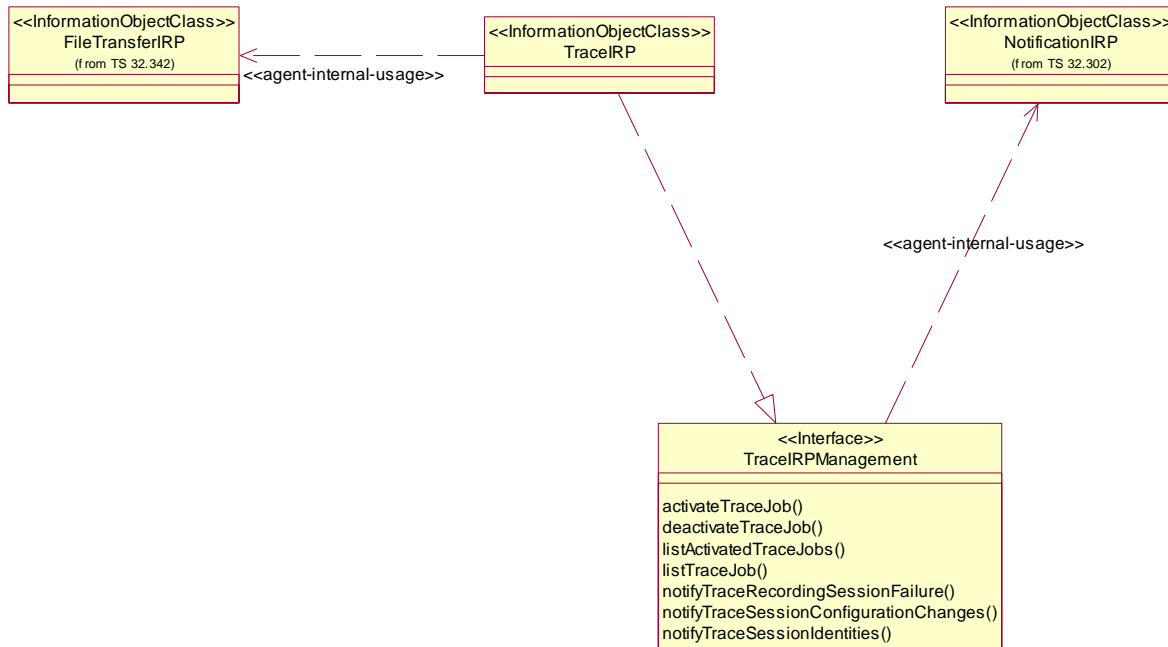

Figure 6.1: Class Diagram

6.2 Generic rules

- **Rule 1:** each operation with at least one input parameter supports a pre-condition `valid_input_parameter` which indicates that all input parameters shall be valid with regards to their information type. Additionally, each such operation supports an exception `operation_failed_invalid_input_parameter` which is raised when pre-condition `valid_input_parameter` is false. The exception has the same entry and exit state.
- **Rule 2:** each operation with at least one optional input parameter supports a set of pre-conditions `supported_optional_input_parameter_xxx` where "xxx" is the name of the optional input parameter and the pre-condition indicates that the operation supports the named optional input parameter. Additionally, each such operation supports an exception `operation_failed_unsupported_optional_input_parameter_xxx` which is raised when (a) the pre-condition `supported_optional_input_parameter_xxx` is false and (b) the named optional input parameter is carrying information. The exception has the same entry and exit state.
- **Rule 3:** each operation shall support a generic exception `operation_failed_internal_problem` which is raised when an internal problem occurs and that the operation cannot be completed. The exception has the same entry and exit state.

NOTE: These rules are mapped at the solution set level. Pre-conditions and exceptions, generated by these rules, need not appear explicitly in the present document.

6.3 TraceIRPManagement (M)

6.3.1 Operation activateTraceJob (M)

6.3.1.1 Definition

This operation support IPRManager"s request to create a TraceJob through Itf-N.

Once the TraceJob has been created, the attributes of the TraceJob will not be modified during the lifetime of the TraceJob.

One TraceJob can manage Trace Sessions in one or more ManagedEntity.

6.3.1.2 Input parameters

Parameter Name	Qualifier	Information type	Comment
iOInstance	M	ManagedEntity.objectInstance	It specifies the DN of ManagedEntity instance where Trace Session is to be activated.
listOfInterfaces	O	TraceJob.listOfInterfaces	
listOfNeTypes	CM	TraceJob.listOfNeTypes	It specifies the type of ManagedFunctions.
traceDepth	M	TraceJob.traceDepth	It shows the traceDepth set to the Trace Session.
traceReference	M	TraceJob.traceReference	It identifies the TraceSession.
traceTarget	M	TraceJob.traceTarget	IMSI or IMEI or IMEISV or Public ID or Private ID or a Cell (identified by its DN id) or an eNB or a RNC. IMSI, IMEI, IMEISV, Public ID, Cell, eNB and RNC are mutually exclusive.
triggeringEvent	CO	TraceJob.triggeringEvent	
traceCollectionEntityAddress	CM,CO	TraceJob.traceCollectionEntityAddress	It specifies the address to the Trace Collection Entity that is associated to the TraceJob. See 3GPP TS 32.422 [9].
jobType	M	TraceJob.jobType	It specifies the type of the TraceJob
mdtAreaScope	CM,CO	TraceJob.mdtAreaScope	It specifies MDT area (Cells/TA/RA/LA) where the Logged MDT measurements shall be collected. It specifies MDT area (list of cells) where the Immediate MDT measurements shall be collected.
listOfMeasurements	CM	TraceJob.listOfMeasurements	It specifies the measurements to be collected from the UE
reportingTrigger	CM	TraceJob.reportingTrigger	It specifies the reporting trigger (event based reporting or periodic reporting) in the UE.
reportInterval	CM	TraceJob.reportInterval	It specifies the interval between the periodical measurements to be taken by the UE.
reportAmount	CM	TraceJob.reportAmount	It specifies the number of measurement reports to be taken in periodical reporting in the UE
eventThreshold	CM	TraceJob.eventThreshold	It specifies the threshold triggering the reporting in case

Parameter Name	Qualifier	Information type	Comment
			of A2 event reporting.
loggingInterval	CM	TraceJob.loggingInterval	It specifies the periodicity of Logged MDT.
loggingDuration	CM	TraceJob.loggingDuration	It specifies the duration of the Logged MDT at the UE.

6.3.1.3 Output parameters

Parameter Name	Qualifier	Matching Information	Comment
status	M	ENUM (Success, Failure, PartialSuccess)	
unsupportedList	M	List of <ManagedEntity, TraceDepth, ListOfInterfaces, TraceTarget, mdtAreaScope, listOfMeasurements, reportingTrigger, reportInterval, reportAmount, eventThreshold, loggingInterval, loggingDuration, reason)	It specifies what attributes are not supported when a Trace Session is activated. The list can contain one or all of the elements and relevant only for error cases.

6.3.1.4 Pre-condition

validTraceReference AND validTraceDepth AND validTraceTarget

Assertion Name	Definition
validTraceDepth	The traceDepth input parameter is valid.
validTraceReference	The traceReference given is not matching to any existing traceReference value in the activated TraceJobs.
validTraceTarget	The traceTarget input parameter is valid.

6.3.1.5 Post-condition

traceSessionActivated

Assertion Name	Definition
traceSessionActivated	The Trace Session identified by the traceReference is activated in the given ManagedEntity instances.

6.3.1.6 Exceptions

Exception Name	Definition
invalidTraceDepth	Condition: (validTraceDepth) is false. Returned Information: output parameter status is set to "Failure". Exit state: Entry State.
invalidTraceTarget	Condition: (validTraceTarget) is false. Returned Information: output parameter status is set to "Failure". Exit state: Entry State.
notuniqueTraceReference	Condition: (validTraceReference) is false. Returned Information: output parameter status is set to "Failure". Exit state: Entry State.

6.3.1.7 Constraints

Name	Definition
listOfNeTypes	It is a Signalling Based Activated trace that is requested.
traceCollectionEntityAddress CM,CO qualifier	Mandatory when tracing in EPS is supported; Mandatory when MDT is supported; Optional when tracing in UMTS is supported
mdtAreaScope	MDT is supported
listOfMeasurements	MDT is supported
reportingTrigger	MDT is supported
reportInterval	MDT is supported
reportAmount	MDT is supported
eventThreshold	MDT is supported
loggingInterval	MDT is supported
loggingDuration	MDT is supported
listOfMeasurements	MDT is supported
traceDepth	Trace is supported
triggeringEvent	Trace is supported

6.3.2 Operation deactivateTraceJob (M)

6.3.2.1 Definition

This operation supports IPRManager"s request to stop a TraceJob through Itf-N. When this operation is received in the TraceIRP the TraceJob shall deactivate the requested Trace Session in the requested ManagedEntity instances.

6.3.2.2 Input parameters

Parameter Name	Qualifier	Information type	Comment
traceReference	M	TraceJob.traceReference	This is a unique ID of the TraceJob
traceTarget	M	TraceJob.traceTarget	(IMSI or IMEI or IMEISV or Public ID or Private ID or a Cell (identified by its DN id) or an eNB or a RNC. IMSI, IMEI, IMEISV, Public ID, Cell, eNB and RNC are mutually exclusive.

6.3.2.3 Output parameters

Parameter Name	Qualifier	Matching Information	Comment
status	M	ENUM (Success, Failure)	The operation may fail because of a specified or an unspecified reason.
traceRecordingSessionReference	CM		This would indicate if a Trace Recording Session is ongoing when the deactivation command has been given.

6.3.2.4 Pre-condition

validTraceReference

Assertion Name	Definition
validTraceReference	The TraceReference input parameter is valid, which means that the TraceIRP is aware of such TraceJob, which has this traceReference value and is aware of the ManagedEntity holding such Trace Session.

6.3.2.4 Post-condition

TraceSessionisdeactivated

Assertion Name	Definition
TraceSessionisdeactivate	The Trace Session identified by the traceReference is deactivated in the requested ManagedEntity instance and the TraceJob is stopped.

6.3.2.6 Exceptions

Exception Name	Definition
notuniqueTraceReference	Condition: (validTraceReference) is false. Returned Information: output parameter status is set to "Failure". Exit state: Entry State.

6.3.3 Operation listTraceJob (M)

6.3.3.1 Definition

This operation support IPRManager"s request to list the parameters of a specific TraceJob through Itf-N.

6.3.3.2 Input parameters

Parameter Name	Qualifier	Information type	Comment
traceReference	M	TraceJob.traceReference	It specifies the Trace Session that is requested for interrogation.

6.3.3.3 Output parameters

Parameter Name	Qualifier	Matching Information	Comment
iOCInstance	M	ManagedElement.objectInstance	It specifies the DN of ManagedElement instance where a Trace Session is activated.
listOfInterfaces	O	TraceJob.listOfInterfaces	It specifies the list of interfaces trace control and configuration parameter that is associated with the TraceJob. See 3GPP TS 32.422 [9]
Status	M	ENUM (Success, Failure)	The operation may fail because of a specified or an unspecified reason.
traceDepth	M	TraceJob.traceDepth	It shows the traceDepth trace control and configuration parameter that is associated to the TraceJob.
traceRecordingSessionReference	CM		This would indicate if a Trace Recording Session is ongoing when the deactivation command has been given.
traceTarget	M	TraceJob.traceTarget	IMSI or IMEI or IMEISV or Public ID or Private ID or a Cell (identified by its DN id) or an eNB or a RNC. IMSI, IMEI, IMEISV, Public ID, Cell, eNB and RNC are mutually exclusive.
triggeringEvent	CO	TraceJob.triggeringEvent	It specifies the triggering event trace control and configuration parameter that is associated to the TraceJob. See 3GPP TS 32.422 [9].
traceCollectionEntityAddress	CM,CO	TraceJob.traceCollectionEntityAddress	It specifies the address to the Trace Collection Entity that is associated to the TraceJob. See 3GPP TS 32.422 [9].
jobType	M	TraceJob.jobType	It specifies the type of the TraceJob. It can be one of the following: Trace, MDT data collection, Trace and MDT data collection.
mdtAreaScope	CM,CO	TraceJob.mdtAreaScope	It specifies MDT area (Cells/TA/RA/LA) where the Logged MDT measurements shall be collected. It specifies MDT area (list of cells) where the Immediate MDT measurements shall be collected.
listOfMeasurements	CM	TraceJob.listofMeasurements	It specifies the measurements to be collected from the UE
reportingTrigger	CM	TraceJob.reportingTrigger	It specifies the reporting trigger (event based reporting or periodic reporting) in the UE.
reportInterval	CM	TraceJob.reportInterval	It specifies the interval between the periodical measurements to be taken by the UE.
reportAmount	CM	TraceJob.reportAmount	It specifies the number of measurement reports to be taken in periodical reporting in the UE
eventThreshold	CM	TraceJob.eventThreshold	It specifies the threshold triggering the reporting in case of A2 event reporting.
loggingInterval	CM	TraceJob.loggingInterval	It specifies the periodicity of the logging for downlink pilot strength measurement in Logged MDT.
loggingDuration	CM	TraceJob.loggingDuration	It specifies the duration of the Logged MDT at the UE.

6.3.3.4 Pre-condition

validTraceReference

Assertion Name	Definition
validTraceReference	The traceReference input parameter is valid, which means that the TraceIRP is aware of such TraceJob, which has this traceReference value and is aware of the ManagedEntity holding such Trace Session.

6.3.3.5 Post-condition

TraceSessionFound

Assertion Name	Definition
TraceSessionFound	The TraceIRP has found the requested TraceJob with the traceReference and can read the configured parameters.

6.3.3.6 Exceptions

Exception Name	Definition
notuniqueTraceReference	Condition: (validTraceReference) is false. Returned Information: output parameter status is set to "Failure". Exit state: Entry State.

6.3.3.7 Constraints

Name	Definition
traceCollectionEntityAddress CM,CO qualifier	Mandatory when tracing in EPS is supported; Mandatory when MDT is supported; Optional when tracing in UMTS is supported
mdtAreaScope	MDT is supported
listOfMeasurements	MDT is supported
reportingTrigger	MDT is supported
reportInterval	MDT is supported
reportAmount	MDT is supported
eventThreshold	MDT is supported
loggingInterval	MDT is supported
loggingDuration	MDT is supported
traceDepth	Trace is supported
triggeringEvent	Trace is supported

6.3.4 Operation listActivatedTraceJobs (M)

6.3.4.1 Definition

This operation support IPRManager"s request to list all the activated TraceJobs through Itf-N.

6.3.4.2 Input parameters

No input parameters for this operation.

6.3.4.3 Output parameters

Parameter Name	Qualifier	Matching Information	Comment
traceReferenceList	M	List of < TraceJob.traceReference.objectinstance >	The TraceReferenceList provides the identification of each activated Trace Session. If no TraceReference can be found, then this list is empty and status is "Success"
status	M	ENUM (Success, Failure)	The operation may fail because of a specified or an unspecified reason.

6.3.5 Notification notifyTraceRecordingSessionFailure (O)

6.3.5.1 Definition

The TraceIRP notifies all subscribed IRPManagers and the Trace Collection Entity (if its address is provided) if a Trace Recording Session in a ManagedEntity has not been started due to any problem.

6.3.5.2 Input parameters

Parameter Name	Qualifiers	Matching Information	Comment
objectClass	M,Y	TraceIRP.objectClass	Notification header
objectInstance	M,Y	TraceIRP.objectInstance	Notification header
eventTime	M,Y	--	Notification header
notificationType	M,Y	"notifyTraceRecordingSessionFailure"	Notification header
systemDN	M,Y	--	Notification header
notificationID	O,Y	--	Notification header
traceRecordingSessionReference	O,N	--	The Trace Recording Session Reference may be visible only in signalling based activation.
traceReference	M,Y	TraceJob.traceReference	
reason	O,N	--	

6.3.5.3 Triggering event

6.3.5.3.1 From state

internalProblemInManagedEntity

Assertion Name	Definition
internalProblemInManagedEntity	Because of an internal problem the ManagedEntity cannot start a Trace Recording Session.

6.3.5.3.2 To state

newNotificationReported

Assertion Name	Definition
newNotificationReported	The " notifyTraceRecordingSessionFailure " notification is emitted to the subscribed IRPManager(s).

6.3.6 Notification notifyTraceSessionLocalActivation (M)

6.3.6.1 Definition

The TraceIRP notifies all subscribed IRPManagers if a Trace Session is configured by the Element Manager.

6.3.6.2 Input parameters

Parameter Name	Qualifiers	Matching Information	Comment
objectClass	M,Y	TraceIRP.objectClass	Notification header
objectInstance	M,Y	TraceIRP.objectInstance	Notification header
eventTime	M,Y	--	Notification header
notificationType	M,Y	"notifyTraceSessionLocalActivation"	Notification header
systemDN	M,Y	--	Notification header
notificationID	O,Y	--	Notification header
traceReference	M,Y	TraceJob.traceReference	
traceTarget	M,Y	TraceJob.traceTarget	
iOCInstance	M,Y	ManagedEntity.objectInstance	

6.3.6.3 Triggering event

6.3.6.3.1 From state

unknownTraceReference

Assertion Name	Definition
unknownTraceReference	The TraceIRP has detected a traceReference associated to a Trace Session in a ManagedEntity that is not initiated via the ltf-N.

6.3.6.3.2 To state

newNotificationReported

Assertion Name	Definition
newNotificationReported	The " notifyTraceSessionLocalActivation " notification is emitted to the subscribed IRPManager(s).

6.3.7 Notification notifyTraceSessionIdentities (CM)

6.3.7.1 Definition

The TraceIRP or the MmeFunction notifies the Trace Collection Entity about the identities of the subscriber and Equipment in case of tracing a session in E-UTRAN only.

6.3.7.2 Input parameters

Parameter Name	Qualifiers	Matching Information	Comment
objectClass	M,Y	TraceIRP.objectClass, or MmeFunction.objectClass	Notification header
objectInstance	M,Y	TraceIRP.objectInstance, or MmeFunction.objectClass	Notification header
eventTime	M,Y	--	Notification header
notificationType	M,Y	"notifyTraceSessionIds"	Notification header
systemDN	M,Y	--	Notification header
notificationID	O,Y	--	Notification header
traceReference	M,Y	TraceJob.traceReference	
traceRecordingSessionReference	M,Y	TraceJob.traceRecordingSessionReference	
traceTarget	M,Y	TraceJob.traceTarget	

6.3.7.3 Triggering event

6.3.7.3.1 From state

FFS

Assertion Name	Definition
FFS	FFS

6.3.7.3.2 To state

FFS

Assertion Name	Definition
FFS	FFS

6.3.7.4 Constraint

Name	Definition
notifyTraceSessionIdentities Notification CM qualifier	Tracing is performed only in E-UTRAN

Annex A (informative): Change history

Change history								
Date	TSG #	TSG Doc.	CR	Rev	Subject/Comment	Cat	Old	New
Apr 2007	S5_52	S5-070445	--	--	Submitted by SA5 prior SA#36 for Information with the intention to get SA#36 Rel-7 Approval for this TS and the CORBA Solution Set TS 32.443	--	1.0.0	
Jun 2007	SP-36	SP-070288	--	--	Submitted to SA#36 for Approval	--	1.0.0	7.0.0
Mar 2008	SP-39	SP-080058	0001	--	Standardize the DN id of UTRAN cell as the identification for the trace target in case of cell traffic trace	F	7.0.0	7.1.0
Dec 2008	SP-42	SP-080846	0002	--	Introducing EPS in Subscriber and Equipment Trace	C	7.1.0	8.0.0
Dec 2009	--	--	--	--	Upgrade to Release 9	--	8.0.0	9.0.0
Jan 2010	--	--	--	--	Removal of track changes and correction of change history	--	9.0.0	9.0.1
Dec 2010	SP-50	SP-100833	003	1	Correcting the Identification of IMS Subscriber Tracing - Align with 32.421	F	9.0.1	10.0.0
Mar 2011	SP-51	SP-110102	004	-	Adding Minimization of Drive Tests (MDT) to Trace IRP	B	10.0.0	10.1.0
May 2011	SP-52	SP-110292	007	1	Add areascope parameter as a MDT configuration	F	10.1.0	10.2.0
Dec 2011	SP-54	SP-110715	0014	2	Support multiple cells in area based MDT	F	10.2.0	10.3.0
Dec 2011	SP-54	SP-110715	0016	2	Add TCE address for UTRAN MDT activation	F	10.2.0	10.3.0
March 2012	SP-55	SP-120053	0019	1	Inconsistency correction on trace target – Align with 32.422	F	10.3.0	10.4.0

History

Document history		
V10.1.0	May 2011	Publication
V10.2.0	June 2011	Publication
V10.3.0	January 2012	Publication
V10.4.0	March 2012	Publication