

# ETSI TS 134 122 V3.5.0 (2001-09)

---

*Technical Specification*

**Universal Mobile Telecommunications System (UMTS);  
Terminal Conformance Specification;  
Radio Transmission and Reception (TDD)  
(3GPP TS 34.122 version 3.5.0 Release 1999)**

---



---

**Reference**

RTS/TSGT-0134122UR6

---

**Keywords**

UMTS

**ETSI**

---

650 Route des Lucioles  
F-06921 Sophia Antipolis Cedex - FRANCE

Tel.: +33 4 92 94 42 00 Fax: +33 4 93 65 47 16

Siret N° 348 623 562 00017 - NAF 742 C  
Association à but non lucratif enregistrée à la  
Sous-Préfecture de Grasse (06) N° 7803/88

---

**Important notice**

Individual copies of the present document can be downloaded from:

<http://www.etsi.org>

The present document may be made available in more than one electronic version or in print. In any case of existing or perceived difference in contents between such versions, the reference version is the Portable Document Format (PDF). In case of dispute, the reference shall be the printing on ETSI printers of the PDF version kept on a specific network drive within ETSI Secretariat.

Users of the present document should be aware that the document may be subject to revision or change of status. Information on the current status of this and other ETSI documents is available at

<http://portal.etsi.org/tb/status/status.asp>

If you find errors in the present document, send your comment to:

[editor@etsi.fr](mailto:editor@etsi.fr)

---

**Copyright Notification**

No part may be reproduced except as authorized by written permission.  
The copyright and the foregoing restriction extend to reproduction in all media.

© European Telecommunications Standards Institute 2001.  
All rights reserved.

---

## Intellectual Property Rights

IPRs essential or potentially essential to the present document may have been declared to ETSI. The information pertaining to these essential IPRs, if any, is publicly available for **ETSI members and non-members**, and can be found in ETSI SR 000 314: "*Intellectual Property Rights (IPRs); Essential, or potentially Essential, IPRs notified to ETSI in respect of ETSI standards*", which is available from the ETSI Secretariat. Latest updates are available on the ETSI Web server (<http://www.etsi.org/legal/home.htm>).

Pursuant to the ETSI IPR Policy, no investigation, including IPR searches, has been carried out by ETSI. No guarantee can be given as to the existence of other IPRs not referenced in ETSI SR 000 314 (or the updates on the ETSI Web server) which are, or may be, or may become, essential to the present document.

---

## Foreword

This Technical Specification (TS) has been produced by ETSI 3rd Generation Partnership Project (3GPP).

The present document may refer to technical specifications or reports using their 3GPP identities, UMTS identities or GSM identities. These should be interpreted as being references to the corresponding ETSI deliverables.

The cross reference between GSM, UMTS, 3GPP and ETSI identities can be found under [www.etsi.org/key](http://www.etsi.org/key).

# Contents

Intellectual Property Rights .....	2
Foreword.....	2
Foreword.....	9
1 Scope .....	10
2 References .....	10
3 Definitions, abbreviations and equations .....	10
3.1 Definitions .....	10
3.2 Abbreviations .....	11
3.3 Equations .....	11
4 Frequency bands and channel arrangement .....	11
4.1 General .....	11
4.2 Frequency bands .....	11
4.3 TX–RX frequency separation .....	12
4.4 Channel arrangement .....	12
4.4.1 Channel spacing .....	12
4.4.2 Channel raster .....	12
4.4.3 Channel number .....	12
5 Transmitter Characteristics .....	12
5.1 General .....	12
5.2 User Equipment maximum output power .....	13
5.2.1 Definition and applicability .....	13
5.2.2 Minimum Requirements .....	13
5.2.3 Test purpose .....	13
5.2.4 Method of test .....	14
5.2.4.1 Initial conditions .....	14
5.2.4.2 Procedure .....	14
5.2.5 Test Requirements .....	14
5.3 UE frequency stability .....	15
5.3.1 Definition and applicability .....	15
5.3.2 Minimum Requirements .....	15
5.3.3 Test purpose .....	15
5.3.4 Method of test .....	15
5.3.4.1 Initial conditions .....	15
5.3.4.2 Procedure .....	16
5.3.5 Test Requirements .....	16
5.4 Output Power Dynamics .....	16
5.4.1 Uplink power control .....	16
5.4.1.1 Initial accuracy .....	16
5.4.1.1.1 Definition and applicability .....	16
5.4.1.1.2 Minimum requirements .....	16
5.4.1.1.3 Test purpose .....	16
5.4.1.1.4 Method of test .....	17
5.4.1.1.4.1 Initial conditions .....	17
5.4.1.1.4.2 Procedure .....	17
5.4.1.1.5 Test requirements .....	17
5.4.1.2 Differential accuracy, controlled input .....	18
5.4.1.2.1 Definition and applicability .....	18
5.4.1.2.2 Minimum requirements .....	18
5.4.1.2.3 Test purpose .....	18
5.4.1.2.4 Method of test .....	18
5.4.1.2.4.1 Initial conditions .....	18
5.4.1.2.4.2 Procedure .....	19
5.4.1.2.5 Test requirements .....	19

5.4.2	Minimum transmit output power .....	20
5.4.2.1	Definition and applicability.....	20
5.4.2.2	Minimum Requirements.....	20
5.4.2.3	Test purpose .....	20
5.4.2.4	Method of test .....	20
5.4.2.4.1	Initial conditions.....	20
5.4.2.4.2	Procedure.....	20
5.4.2.5	Test requirements.....	20
5.4.3	Transmit OFF power.....	21
5.4.3.1	Definition and applicability.....	21
5.4.3.2	Minimum Requirements.....	21
5.4.3.3	Test purpose .....	21
5.4.3.4	Method of test .....	21
5.4.3.5	Test requirements.....	21
5.4.4	Transmit ON/OFF Time mask.....	21
5.4.4.1	Definition and applicability.....	21
5.4.4.2	Minimum requirements.....	21
5.4.4.3	Test Purpose.....	22
5.4.4.4	Method of test .....	22
5.4.4.4.1	Initial conditions.....	22
5.4.4.4.2	Procedure.....	22
5.4.4.5	Test requirements .....	22
5.4.5	Out-of-synchronisation handling of output power.....	23
5.4.5.1	Definition and applicability.....	23
5.4.5.2	Minimum Requirement .....	23
5.4.5.3	Test purpose .....	24
5.4.5.4	Method of test .....	24
5.4.5.4.1	Initial conditions.....	24
5.4.5.4.2	Procedure.....	25
5.4.5.5	Test Requirements.....	25
5.5	Output RF spectrum emissions.....	25
5.5.1	Occupied bandwidth .....	25
5.5.1.1	Definition and applicability.....	25
5.5.1.2	Minimum Requirements.....	25
5.5.1.3	Test purpose .....	26
5.5.1.4	Method of test .....	26
5.5.1.4.1	Initial conditions.....	26
5.5.1.4.2	Procedure.....	26
5.5.1.5	Test requirements.....	26
5.5.2	Out of band emission .....	27
5.5.2.1	Spectrum emission mask.....	27
5.5.2.1.1	Definition and applicability.....	27
5.5.2.1.2	Minimum Requirements .....	27
5.5.2.1.3	Test purpose .....	27
5.5.2.1.4	Method of test.....	27
5.5.2.1.5	Test requirements .....	28
5.5.2.2	Adjacent Channel Leakage power Ratio (ACLR).....	28
5.5.2.2.1	Definition and applicability .....	28
5.5.2.2.2	Minimum Requirements .....	28
5.5.2.2.3	Test purpose .....	28
5.5.2.2.4	Method of test.....	29
5.5.2.2.5	Test requirements .....	29
5.5.3	Spurious emissions .....	29
5.5.3.1	Definition and applicability.....	29
5.5.3.2	Minimum Requirements.....	30
5.5.3.3	Test purpose .....	30
5.5.3.4	Method of test .....	30
5.5.3.4.1	Initial conditions.....	30
5.5.3.4.2	Procedure.....	30
5.5.3.5	Test requirements.....	31
5.6	Transmit Intermodulation.....	31
5.6.1	Definition and applicability .....	31

5.6.2	Minimum Requirements .....	31
5.6.3	Test purpose.....	32
5.6.4	Method of test .....	32
5.6.4.1	Initial conditions .....	32
5.6.4.2	Procedure .....	32
5.6.5	Test requirements.....	32
5.7	Transmit Modulation .....	33
5.7.1	Error Vector Magnitude.....	33
5.7.1.1	Definition and applicability.....	33
5.7.1.2	Minimum Requirements.....	33
5.7.1.3	Test purpose .....	33
5.7.1.4	Method of test .....	33
5.7.1.4.1	Initial conditions .....	33
5.7.1.4.2	Procedure.....	33
5.7.1.5	Test requirements.....	33
5.7.2	Peak code domain error .....	34
5.7.2.1	Definition and applicability.....	34
5.7.2.2	Minimum Requirement .....	34
5.7.2.3	Test purpose .....	34
5.7.2.4	Method of test .....	34
5.7.2.4.1	Initial conditions .....	34
5.7.2.4.2	Procedure.....	34
5.7.2.5	Test requirements .....	35
6	Receiver Characteristics .....	35
6.1	General .....	35
6.2	Reference sensitivity level.....	35
6.2.1	Definition and applicability .....	35
6.2.2	Minimum Requirements .....	35
6.2.3	Test purpose.....	36
6.2.4	Method of test .....	36
6.2.4.1	Initial conditions .....	36
6.2.4.2	Procedure .....	36
6.2.5	Test requirements.....	36
6.3	Maximum Input Level.....	36
6.3.1	Definition and applicability .....	36
6.3.2	Minimum requirements.....	36
6.3.3	Test purpose.....	37
6.3.4	Method of test .....	37
6.3.4.1	Initial conditions .....	37
6.3.4.2	Procedure .....	37
6.3.5	Test requirements.....	37
6.4	Adjacent Channel Selectivity (ACS).....	37
6.4.1	Definition and applicability .....	37
6.4.2	Minimum Requirements .....	37
6.4.3	Test purpose.....	38
6.4.4	Method of test .....	38
6.4.4.1	Initial conditions .....	38
6.4.4.2	Procedure .....	38
6.4.5	Test Requirements .....	38
6.5	Blocking Characteristics.....	39
6.5.1	Definition and applicability .....	39
6.5.2	Minimum Requirements .....	39
6.5.3	Test purpose.....	40
6.5.4	Method of test .....	40
6.5.4.1	Initial conditions .....	40
6.5.4.2	Procedure .....	41
6.5.5	Test requirements.....	41
6.6	Spurious Response .....	42
6.6.1	Definition and applicability .....	42
6.6.2	Minimum Requirements .....	42
6.6.3	Test purpose.....	42

6.6.4	Method of test .....	42
6.6.4.1	Initial conditions .....	42
6.6.4.2	Procedure .....	42
6.6.5	Test requirements.....	43
6.7	Intermodulation Characteristics.....	43
6.7.1	Definition and applicability .....	43
6.7.2	Minimum Requirements .....	43
6.7.3	Test purpose.....	43
6.7.4	Method of test.....	44
6.7.4.1	Initial conditions .....	44
6.7.4.2	Procedure .....	44
6.7.5	Test requirements.....	44
6.8	Spurious Emissions .....	44
6.8.1	Definition and applicability .....	44
6.8.2	Minimum Requirements .....	44
6.8.3	Test purpose.....	45
6.8.4	Method of test.....	45
6.8.4.1	Initial conditions .....	45
6.8.4.2	Procedure .....	45
6.8.5	Test requirements.....	45
7	Performance Requirements .....	46
7.1	General .....	46
7.2	Demodulation in static propagation conditions .....	46
7.2.1	Demodulation of DCH.....	46
7.2.1.1	Definition and applicability.....	46
7.2.1.2	Minimum requirements .....	46
7.2.1.3	Test purpose .....	47
7.2.1.4	Method of test .....	47
7.2.1.4.1	Initial conditions.....	47
7.2.1.4.2	Procedure.....	47
7.2.1.5	Test requirements.....	47
7.3	Demodulation of DCH in multipath fading conditions .....	48
7.3.1	Multipath fading Case 1.....	48
7.3.1.1	Definition and applicability.....	48
7.3.1.2	Minimum requirements .....	48
7.3.1.3	Test purpose .....	48
7.3.1.4	Method of test .....	48
7.3.1.4.1	Initial conditions.....	48
7.3.1.4.2	Procedure.....	49
7.3.1.5	Test requirements.....	49
7.3.2	Multipath fading Case 2.....	49
7.3.2.1	Definition and applicability.....	49
7.3.2.2	Minimum requirement .....	49
7.3.2.3	Test purpose .....	50
7.3.2.4	Method of test .....	50
7.3.2.4.1	Initial conditions.....	50
7.3.2.4.2	Procedure.....	50
7.3.2.5	Test requirements.....	50
7.3.3	Multipath fading Case 3.....	50
7.3.3.1	Definition and applicability.....	50
7.3.3.2	Minimum requirements.....	50
7.3.3.3	Test purpose .....	51
7.3.3.4	Method of test .....	51
7.3.3.4.1	Initial conditions.....	51
7.3.3.4.2	Procedure.....	51
7.3.3.5	Test requirements .....	52
7.4	Base station transmit diversity mode.....	52
7.4.1	Demodulation of BCH in Block STTD mode .....	52
7.5	Power control in downlink .....	52
7.5.1	Minimum requirements.....	52

8	Requirements for Support of RRM .....	52
8.1	General .....	52
8.2	Idle Mode Tasks .....	52
8.2.1	Introduction.....	52
8.2.2	RF Cell Selection Scenario .....	53
8.2.2.1	Requirements for Cell Selection single carrier single cell case.....	53
8.2.2.2	Requirements for Cell Selection multicarrier carrier multi cell case .....	53
8.2.3	RF Cell Re-Selection Scenario .....	53
8.2.3.1	Requirements for Cell Re-Selection single carrier multi cell case.....	53
8.2.4	PLMN Selection and Re-Selection Scenario .....	53
8.2.5	Location Registration Scenario.....	53
8.3	RRC Connection mobility .....	53
8.3.1	Handover .....	53
8.3.1.1	Introduction.....	53
8.3.1.2	Handover 3G to 3G.....	53
8.3.1.2.1	TDD/TDD Handover.....	53
8.3.1.2.2	TDD/FDD Handover .....	53
8.3.1.3	Handover 3G to 2G .....	53
8.3.1.3.1	Handover to GSM.....	53
8.3.2	Radio Link Management .....	53
8.3.2.1	Link adaptation .....	53
8.3.3	Cell Update .....	54
8.3.4	URA Update .....	54
8.4	RRC Connection Control .....	54
8.4.1	Radio Access Bearer Control.....	54
8.5	Dynamic Channel Allocation .....	54
8.6	Timing characteristics .....	54
8.6.1	Timing Advance (TA) Requirements .....	54
8.7	Measurements Performance Requirements .....	54
8.7.1	Measurements Performance for UE.....	54
<b>Annex A (informative): Connection Diagrams .....</b>		<b>55</b>
<b>Annex B (normative): Global In-Channel TX-Test.....</b>		<b>59</b>
B.1	General .....	59
B.2	Definition of the process .....	59
B.2.1	Basic principle.....	59
B.2.2	Output signal of the TX under test .....	59
B.2.3	Reference signal .....	59
B.2.4	void.....	60
B.2.5	Classification of measurement results .....	60
B.2.6	Process definition to achieve results of type "deviation" .....	60
B.2.7	Process definition to achieve results of type "residual".....	61
B.2.7.1	Error Vector Magnitude (EVM) .....	61
B.2.7.2	Peak Code Domain Error (PCDE) .....	61
B.3	Notes.....	62
<b>Annex C (normative): Measurement channels .....</b>		<b>64</b>
C.1	General .....	64
C.2	UL Reference measurement channels .....	65
C.2.1	UL reference measurement channel (12.2 kbps).....	65
C.2.2	UL multi code reference measurement channel (12.2 kbps) .....	66
C.2.3	UL reference measurement channel (64 kbps) .....	67
C.2.4	UL reference measurement channel (144 kbps) .....	68
C.2.5	UL reference measurement channel (384 kbps) .....	69
C.3	DL Reference measurement channels .....	70
C.3.1	DL reference measurement channel (12.2 kbps) .....	70
C.3.2	DL reference measurement channel (64 kbps) .....	71



C.3.3	DL reference measurement channel (144 kbps) .....	72
C.3.4	DL reference measurement channel (384 kbps) .....	73
C.3.5	BCH reference measurement channel .....	74
<b>Annex D (normative): Propagation conditions .....</b>		<b>75</b>
D.1	Test Environments.....	75
D.2	Propagation Conditions .....	75
D.2.1	Static propagation condition.....	75
D.2.2	Multi-path fading propagation conditions .....	75
<b>Annex E (normative): Common RF test conditions .....</b>		<b>76</b>
E.1	General .....	76
E.2	Connection Set-up .....	76
E.3	During connection .....	76
E.3.1	Measurement of Tx Characteristics .....	76
E.3.2	Measurement of Rx Characteristics.....	77
E.3.3	Measurement of Performance requirements .....	77
<b>Annex F (normative): General test conditions and declarations.....</b>		<b>78</b>
F.1	Acceptable uncertainty of Test System .....	78
F.1.1	Measurement of test environments.....	78
F.1.2	Measurement of transmitter.....	79
F.1.3	Measurement of receiver .....	80
F.1.4	Performance requirement .....	80
F.1.5	Requirements for support of RRM .....	80
F.2	Test Tolerances (This clause is informative).....	80
F.2.1	Transmitter .....	81
F.2.2	Receiver.....	81
F.2.3	Performance requirements.....	81
F.2.4	Requirements for support of RRM .....	82
F.3	Interpretation of measurement results .....	82
F.4	Derivation of Test Requirements (This clause is informative).....	82
F.5	Acceptable uncertainty of Test Equipment (This clause is informative) .....	86
F.5.1	Transmitter measurements.....	86
F.5.2	Receiver measurements .....	86
F.5.3	Performance measurements .....	86
F.6	General rules for statistical testing .....	87
<b>Annex G (normative): Environmental conditions .....</b>		<b>88</b>
G.1	General .....	88
G.2	Environmental requirements .....	88
G.2.1	Temperature .....	88
G.2.2	Voltage .....	88
G.2.3	Vibration.....	89
G.2.4	Specified frequency range .....	89
<b>Annex H (normative): Terminal Baseline and Service Implementation Capabilities (TDD).....</b>		<b>90</b>
H.1	Baseline Implementation Capabilities:.....	90
H.2	Service Implementation Capabilities: .....	90
<b>Annex I (informative): Change history .....</b>		<b>91</b>
History .....		92

---

# Foreword

This Technical Specification (TS) has been produced by the 3<sup>rd</sup> Generation Partnership Project (3GPP).

The contents of the present document are subject to continuing work within the TSG and may change following formal TSG approval. Should the TSG modify the contents of the present document, it will be re-released by the TSG with an identifying change of release date and an increase in version number as follows:

Version x.y.z

where:

- x the first digit:
  - 1 presented to TSG for information;
  - 2 presented to TSG for approval;
  - 3 or greater indicates TSG approved document under change control.
- y the second digit is incremented for all changes of substance, i.e. technical enhancements, corrections, updates, etc.
- z the third digit is incremented when editorial only changes have been incorporated in the document.

---

# 1 Scope

This present document specifies the measurement procedure for the conformance test of the mobile station that contain transmitting characteristics, receiving characteristics and performance requirements and requirements for support of RRM (Radio Resource Management) in TDD mode.

---

# 2 References

The following documents contain provisions which, through reference in this text, constitute provisions of the present document.

- References are either specific (identified by date of publication, edition number, version number, etc.) or non-specific.
- For a specific reference, subsequent revisions do not apply.
- For a non-specific reference, the latest version applies. In the case of a reference to a 3GPP document (including a GSM document), a non-specific reference implicitly refers to the latest version of that document *in the same Release as the present document*.

[1] 3GPP TS 25.102: "UTRA (UE) TDD Radio Transmission and Reception (TDD)".

Note: The current version reflects 3G TS 25.102 version 3.2.0.

In addition CRs agreed on RAN4 level (Meeting #13, Turku, Finland, May 2000) are taken into account.

[2] 3GPP TS 25.123: "Requirements for Support of Radio Resource Management (TDD)".

[3] 3GPP TS 34.108 "Common Test Environments for User Equipment (UE) Conformance Testing"

[4] 3GPP TS 34.109: " Terminal logical test interface; Special conformance testing functions".

[5] 3GPP TS 25.224: "Physical Layer Procedures (TDD)".

[6] 3GPP TR 21.905: "Vocabulary for 3GPP Specifications".

[7] 3GPP TR 25.990: "Vocabulary".

[8] ITU-R Recommendation SM.328-9: "Spectra and bandwidth of emissions".

[9] 3GPP TS 25.331: "Radio Resource Control (RRC) Protocol Specification".

---

# 3 Definitions, abbreviations and equations

For the purposes of the present document, the definitions, symbols, abbreviations and equations used in the present document are listed in TR 21.905 [6] and TR 25.990 [7].

## 3.1 Definitions

For the purpose of the present document, the following definition applies:

**Average power:** [TBD]

## 3.2 Abbreviations

For the purpose of the present document, the following abbreviations apply.

AFC	Automatic Frequency Control
ATT	Attenuator
EVM	Error Vector Magnitude
FFS	For Further Study
HYB	Hybrid
OBW	Occupied Bandwidth
OCNS	Orthogonal Channel Noise Simulator, a mechanism used to simulate the users or control signals on the other orthogonal channels of a downlink.
PCDE	Peak Code Domain Error
PRBS	Pseudo Random Bit Sequence
RRC	Root-Raised Cosine
SS	System Simulator
TBD	To Be Defined
TS	Time Slot

## 3.3 Equations

For the purpose of the present document, the following additional equations apply:

$I_{BTS}$	Interference signal power level at BTS in dBm, which is broadcasted on BCH
$I_{oac}$	The power spectral density of the adjacent frequency channel as measured at the UE antenna connector.
$\frac{\sum DPCH_{Ec}}{I_{or}}$	The ratio of the sum of DPCH_Ec for one service in case of multicode to the total transmit power spectral density of the downlink at the BS antenna connector

---

# 4 Frequency bands and channel arrangement

## 4.1 General

The information presented in this clause is based on a chip rate of 3,84 Mcps.

NOTE: Other chip rates may be considered in future releases.

## 4.2 Frequency bands

UTRA/TDD is designed to operate in the following bands;

- a) 1 900 – 1 920 MHz: Uplink and downlink transmission  
2 010 – 2 025 MHz: Uplink and downlink transmission
- b) 1 850 – 1 910 MHz: Uplink and downlink transmission (note)  
1 930 – 1 990 MHz: Uplink and downlink transmission
- c) 1 910 – 1 930 MHz: Uplink and downlink transmission (note)

NOTE: Used in ITU Region 2.

Additional allocations in ITU region 2 are for further study.

Deployment in existing or other frequency bands is not precluded.

## 4.3 TX–RX frequency separation

No TX-RX frequency separation is required as Time Division Duplex (TDD) is employed. Each TDMA frame consists of 15 timeslots where each timeslot can be allocated to either transmit or receive.

## 4.4 Channel arrangement

### 4.4.1 Channel spacing

The nominal channel spacing is 5 MHz, but this can be adjusted to optimise performance in a particular deployment scenario.

### 4.4.2 Channel raster

The channel raster is 200 kHz, which means that the carrier frequency must be a multiple of 200 kHz.

### 4.4.3 Channel number

The carrier frequency is designated by the UTRA absolute radio frequency channel number (UARFCN). The value of the UARFCN in the IMT2000 band is defined as follows:

$$N_t = 5 * F \quad 0,0 \text{ MHz} \leq F \leq 3276,6 \text{ MHz} \quad \text{where } F \text{ is the carrier frequency in MHz}$$

---

# 5 Transmitter Characteristics

## 5.1 General

Transmitting performance test of the UE is implemented during communicating with the SS via air interface. The procedure is uses normal call protocol until the UE is communicating on traffic channel basically. (Refer to TS 34.108 [3] Common Test Environments for User Equipment (UE) Conformance Testing) On the traffic channel, the UE provides special function for testing that is called Logical Test Interface and the UE is tested using this function. (Refer to TS 34.109 [4] Logical Test Interface; Special conformance testing functions).

Unless detailed the transmitter characteristic are specified at the antenna connector of the UE. For UE with integral antenna only, a reference antenna with a gain of 0 dBi is assumed. Transmitter characteristics for UE(s) with multiple antennas/antenna connectors are for further study.

The UE antenna performance has a significant impact on system performance, and minimum requirements on the antenna efficiency are therefore intended to be included in future versions of the present document. It is recognized that different requirements and test methods are likely to be required for the different types of UE.

The common RF test conditions are defined in annex E, and each test conditions in this Clause should refer annex E. Individual test conditions are defined in the paragraph of each test.

## 5.2 User Equipment maximum output power

### 5.2.1 Definition and applicability

The maximum output power and its tolerance are defined according to the Power Class of the UE.

The **output power**,  $P_{out}$ , of the UE is the power when averaged (in the sense of thermal power) over the useful part of the TS at the maximum power control setting delivered in to a load with resistance equal to the nominal load impedance.

The requirements in this test apply to all UTRA – TDD- UEs

Notes copied from TS 25.102 clause 6.2.1:

NOTE 1: The maximum output power refers to.....

NOTE 2: For multi-code operation the maximum output power will be reduced by the difference of peak to average ratio between single and multi-code transmission.

NOTE 3: The tolerance of the maximum power is below the prescribed value even at the multi-code transmission mode

NOTE 4: For UE using directive antennas for transmission, a class dependent limit will be placed on the maximum EIRP (Equivalent Isotropic Radiated Power).

### 5.2.2 Minimum Requirements

The error of the UE maximum output power shall not exceed the tolerance shown in tables 5.2.2 a and b for single and multi-code.

**Table 5.2.2.a: Maximum Output Power single code**

Power Class	Maximum output power	Tolerance
2	+24 dBm	+1dB/-3dB
3	+21 dBm	+2dB/-2dB

**Table 5.2.2.b: Maximum Output Power multi code**

Power Class	Maximum output power	Tolerance
2	[21] dBm (note)	+1dB/-3dB
3	[18] dBm (note)	+2dB/-2dB
NOTE: These figures are not mentioned in 25.102. Instead there is a note, saying: "For multi-code operation the maximum output power will be reduced by the difference of peak to average ratio between single and multi-code transmission." The figures are calculated from maximum output power single code (table 5.2.2.a) and UL multicode reference measurement channel (12,2 kbit/s) (annex C.2.2.) containing two code signals with equal level.		

The normative reference for this requirement is TS 25.102 clause 6.2.

### 5.2.3 Test purpose

For the following reasons:

Limit interference.

Verify that the maximum output power is achievable.

It is the purpose of the test to verify that the UE's maximum output power is within its tolerance limits under all environmental conditions.

## 5.2.4 Method of test

### 5.2.4.1 Initial conditions

Test environment: normal, TL/VL, TL/VH, TH/VL, TH/VH; see clauses G.2.1 and G.2.2.

Frequencies to be tested: low range, mid range, high range; see clause G.2.4.

- 1) Connect the SS to the UE antenna connector as shown in figure A.1.
- 2) Calls are set up according to the Generic call setup procedure using parameters as specified in tables 5.2.4.a and b.
- 3) Enter the UE into loopback test mode and start the loopback test.

**Table 5.2.4.a: Test parameters for Maximum Output Power single code**

Parameter	Value/description
UL Reference measurement channel	12,2kbps, according to annex C.2.1
Uplink Power Control	SS level and signalling values such that UE transmits maximum power.
Data content	real life (sufficient irregular)

**Table 5.2.4.b: Test parameters for Maximum Output Power multicode**

Parameter	Value/description
Reference measurement channel	Multicode 12,2kbps, according to annex C.2.2
Uplink Power Control	SS level and signalling values such that UE transmits maximum power
Data content	real life (sufficient irregular)

### 5.2.4.2 Procedure

- 1) Measure thermal power over the useful part of the burst with a measurement bandwidth of at least 5 MHz.
- 2) Run step 1) on RF channels Low / Mid / High.

## 5.2.5 Test Requirements

The output power, measured in step 2) of clause 5.2.4.2, shall not exceed the prescribed tolerance in table 5.2.5 a and b.

**Table 5.2.5.a: Maximum Output Power single code**

Power Class	Maximum output power	Tolerance
2	+24 dBm	+1,7 dB / -3,7dB
3	+21 dBm	+2,7 dB / -2,7dB

**Table 5.2.5.b: Maximum Output Power multi code**

Power Class	Maximum output power	Tolerance
2	[ 21 ] dBm	+1,7dB / -3,7 dB
3	[ 18 ] dBm	+2,7dB / -2,7 dB

NOTE: If the above Test Requirement differs from the Minimum Requirement then the Test Tolerance applied for this test is non-zero. The Test Tolerance for this test is defined in annex F clause F.2 and the explanation of how the Minimum Requirement has been relaxed by the Test Tolerance is given in Annex F clause F.4.

## 5.3 UE frequency stability

### 5.3.1 Definition and applicability

The frequency stability is the difference of the modulated carrier frequency between the RF transmission from the UE and the RF transmission from the BS. The UE shall use the same frequency source for both RF frequency generation and chip clocking.

The requirements of this test apply to all types of UTRA- UE.

### 5.3.2 Minimum Requirements

The UE frequency stability, observed over a period of one timeslot, shall be within  $\pm 0,1$  ppm compared to signals received from the BS.

The normative reference for this requirement is TS 25.102 [1] clause 6.3.

### 5.3.3 Test purpose

Reliable frequency stability of the UE's transmitter in certain tolerance limits is prerequisite for connectivity.

This test stresses the ability of the UE's receiver to derive correct frequency information from the received signal for the transmitter.

### 5.3.4 Method of test

#### 5.3.4.1 Initial conditions

Test environment: normal, TL/VL, TL/VH, TH/VL, TH/VH, vibration; see clauses G.2.1, G.2.2 and G.2.3.

Frequencies to be tested: low range, mid range, high range; see clause G.2.4.

- 1) Connect the SS to the UE antenna connector as shown in figure A.1.
- 2) A call is set up according to the Generic call setup procedure using parameters as specified in table 5.3.4.1.
- 3) Enter the UE into loopback test mode and start the loopback test.

**Table 5.3.4.1: Test parameters for Frequency Stability**

Parameter	Value/description
SS level	-105 dBm (reference sensitivity)
UL reference measurement channel	12,2 kbps according to annex C.2.1.
Data content	real life (sufficient irregular)



### 5.3.4.2 Procedure

- 1) Measure the frequency error  $\Delta f$  across the TS according to annex B.
- 2) Repeat step 1) for 200 bursts (time slots).
- 3) Run Step 1) and 2) for RF channels Low /Mid/ High.

### 5.3.5 Test Requirements

For all measured bursts (time slots) , the frequency error, derived in clause 5.3.4.2, shall not exceed  $\pm (0,1 \text{ ppm} + 10 \text{ Hz})$ .

NOTE: If the above Test Requirement differs from the Minimum Requirement then the Test Tolerance applied for this test is non-zero. The Test Tolerance for this test is defined in annex F clause F.2 and the explanation of how the Minimum Requirement has been relaxed by the Test Tolerance is given in annex F clause F.4

## 5.4 Output Power Dynamics

Power control is used to limit the interference level.

### 5.4.1 Uplink power control

Uplink power control is the ability of the UE transmitter to sets its output power in accordance with measured downlink path loss, values determined by higher layer signalling and path loss weighting parameter  $\alpha$  as defined in TS 25.331 [9]. The output power is defined as the average power of the transmit timeslot, and is measured with a filter that has a Root-Raised Cosine (RRC) filter response with a roll off  $\alpha = 0.22$  and a bandwidth equal to the chip rate.

#### 5.4.1.1 Initial accuracy

##### 5.4.1.1.1 Definition and applicability

Initial Uplink power control is the ability of the UE transmitter to sets its output power in accordance with measured downlink path loss, and signalling values:  $I_{BTS}$  and Constant value, received from the BCH and applicable for the PRACH

The requirements and this test apply to all types of UTRA - UEs.

##### 5.4.1.1.2 Minimum requirements

The UE power control, initial accuracy, is given in table 5.4.1.1.2.

**Table 5.4.1.1.2: Initial uplink power control tolerance**

Normal conditions	$\pm 9 \text{ dB}$
Extreme conditions	$\pm 12 \text{ dB}$

The reference for this requirement is TS 25.102 [1] clause 6.4.1.1.

##### 5.4.1.1.3 Test purpose

The power of the received signal at the UE and the BCCH information control the power of the transmitted UE signal with the target to transmit at lowest power, acceptable for proper communication.

The test stresses the ability of the receiver to measure the received power over the receiver dynamic range and to derive from this correct transmitter-power

#### 5.4.1.1.4 Method of test

##### 5.4.1.1.4.1 Initial conditions

Test environment: normal, TL/VL, TL/VH, TH/VL, TH/VH; see clauses G.2.1 and G.2.2.

Frequencies to be tested: low range, mid range, high range; see clause G.2.4.

Connect the SS to the MS antenna connector as shown in figure A.1.

A call is set up according to the generic call setup procedure [3] using parameters as specified in table 5.4.1.1.4. The RACH procedure within the call setup is used for the test.

**Table 5.4.1.1.4: Test parameters for uplink Power Control**

	RX-Upper dynamic end	RX-middle	RX-Sensitivity level
SS transmit power	-25 dBm/3,84 MHz	-65 dBm/3,84 MHz	-105 dBm/3,84 MHz
Broadcasted transmit-power CCPCH	35 dBm	35 dBm	24 dBm
Simulated path loss = Broadcasted TX – SS TX Power	60 dB	100 dB	129 dB
$I_{BTS}$ (UL interference)	-75 dBm	-100 dBm	-110 dBm
Constant value	-10 dB	-10 dB	-10 dB
Nominal expected UE TX power	-25 dBm	-10 dBm	+9 dBm <sup>2)</sup>
NOTE 1: While the SS transmit power shall cover the UE receiver input dynamic range, the logical parameters: broadcasted transmit power, $I_{BTS}$ , and RACH constant value are chosen to achieve a UE TX power, located within the TX output power dynamic range of a class 3 UE.			
NOTE 2: Nominal TX output power 9 dBm allows to check the uplink power control algorithm within the entire tolerance range (9 dBm +12 dB: 9 dBm +12 dB =21 dBm = max power class 3).			

##### 5.4.1.1.4.2 Procedure

- 1) Set the SS transmit power according to table 5.4.1.1.4.
- 2) Measure the RACH output power of the UE according to annex B.
- 3) Repeat the test for all SS transmit powers and parameters in table 5.4.1.1.4.

#### 5.4.1.1.5 Test requirements

The deviation with respect to the nominal expected UE TX power (table 5.4.1.1.2), derived in step 2, shall not exceed the prescribed tolerance in table 5.4.1.1.5.

**Table 5.4.1.1.5: Test parameters for uplink Power Control**

Expected UE TX power, normal conditions	-25 dBm $\pm$ 10 dB	-10 dBm $\pm$ 10 dB	+9 dBm $\pm$ 10 dB
Expected UE TX power, extreme conditions	-25 dBm $\pm$ 13 dB	-10 dBm $\pm$ 13 dB	+9 dBm $\pm$ 13 dB

NOTE: If the above Test Requirement differs from the Minimum Requirement then the Test Tolerance applied for this test is non-zero. The Test Tolerance for this test is defined in annex F clause F.2 and the explanation of how the Minimum Requirement has been relaxed by the Test Tolerance is given in annex F clause F.4.

## 5.4.1.2 Differential accuracy, controlled input

### 5.4.1.2.1 Definition and applicability

Uplink power control, differential accuracy, is the ability of the UE transmitter to sets its output power in accordance with measured downlink path loss, and the signalling values:  $I_{BTS}$ ,  $SIR_{Target}$ , Constant Value, received from higher layers and applicable for the DPCH.

Specifically, the uplink power control, differential accuracy, controlled input, is defined as the error in the UE transmitter power step as a result of a step in  $SIR_{TARGET}$  when the path loss weighting parameter  $\alpha=0$ ,  $\alpha$  calculated in the UE.

The requirements of this test apply to all types of UTRA -UE.

### 5.4.1.2.2 Minimum requirements

The step in  $SIR_{TARGET}$  shall be rounded to the closest integer dB value. The error shall not exceed the values in table 5.4.1.2.2.

**Table 5.4.1.2.2: Transmitter power step tolerance as a result of control power step**

$\Delta SIR_{TARGET}$ [dB]	Transmitter power step tolerance [dB]
$\Delta SIR_{TARGET} \leq 1$	$\pm 0,5$
$1 < \Delta SIR_{TARGET} \leq 2$	$\pm 1$
$2 < \Delta SIR_{TARGET} \leq 3$	$\pm 1,5$
$3 < \Delta SIR_{TARGET} \leq 10$	$\pm 2$
$10 < \Delta SIR_{TARGET} \leq 20$	$\pm 4$
$20 < \Delta SIR_{TARGET} \leq 30$	$\pm 6$
$30 < \Delta SIR_{TARGET}$	$\pm 9$ (note)
NOTE: Value is given for normal conditions. For extreme conditions value is $\pm 12$ .	

The reference for this requirement is TS 25.102 [1] clause 6.4.1.2.

### 5.4.1.2.3 Test purpose

It is verified if the UE sets correct uplink power steps in response to steps in the signalling value  $SIR_{Target}$ , signalled via the downlink to the UE.

under the following conditions: keeping the other signalling parameters constant and deactivating any influence due to varying pathloss.

### 5.4.1.2.4 Method of test

#### 5.4.1.2.4.1 Initial conditions

Test environment: normal; see clauses G.2.1 and G.2.2.

Frequencies to be tested: mid range; see clause G.2.4.

- 1) Connect the SS to the MS antenna connector as shown in figure A.1.
- 2) A call is set up according to the generic call setup procedure using parameters as specified in table 5.4.1.2.4.

**Table 5.4.1.2.4: Test parameters for Uplink Power Control, Differential Accuracy, Controlled Input**

Parameter	Value/description
UL reference measurement channel	12,2 kbps according to annex C clause C.2.1.
BS Transmit to UE Transmit delay	7 TSS--> $\alpha=0$
SSTransmit power	[-65 dBm]
Reference transmit power broadcast on BCH	[35 dBm]
IBTS	[-100]
Constant value	[-10]
Data content	real life (sufficient irregular)

#### 5.4.1.2.4.2 Procedure

Using the  $SIR_{Target}$  -value in the downlink,

cover the UE-transmitter dynamic range by commanding the UEs power with the signalling value  $SIR_{Target}$  in a step resolution (positive and negative direction) of:

- |                  |                                       |
|------------------|---------------------------------------|
| 1 dB             | approx. 68 steps up and 68 steps down |
| 2 dB             | approx. 34 steps up and 34 steps down |
| 3 dB             | approx. 22 steps up and 22 steps down |
| 10 dB            | approx. 7 steps up and 7 steps down   |
| 20 dB            | approx. 3 steps up and 3 steps down   |
| 30 dB            | approx. 2 step up and 2 step down     |
| maximum stepsize | 1 step up and 1 step down             |

Measure the power according to annex B.

#### 5.4.1.2.5 Test requirements

For the UE output power laying between

Max Power minus tolerance and Min Power

the step response shall not exceed the prescribed tolerance in table 5.4.1.2.5.

**Table 5.4.1.2.5: Transmitter power step tolerance as a result of control power step**

$\Delta SIR_{TARGET}$ [dB]	Transmitter power step tolerance [dB]
$\Delta SIR_{TARGET} \leq 1$	$\pm 0,6$
$1 < \Delta SIR_{TARGET} \leq 2$	$\pm 1,15$
$2 < \Delta SIR_{TARGET} \leq 3$	$\pm 1,7$
$3 < \Delta SIR_{TARGET} \leq 10$	$\pm 2,5$
$10 < \Delta SIR_{TARGET} \leq 20$	$\pm 4,7$
$20 < \Delta SIR_{TARGET} \leq 30$	$\pm 6,7$
$30 < \Delta SIR_{TARGET}$	$\pm 10$

NOTE: If the above Test Requirement differs from the Minimum Requirement then the Test Tolerance applied for this test is non-zero. The Test Tolerance for this test is defined in annex F clause F.2 and the explanation of how the Minimum Requirement has been relaxed by the Test Tolerance is given in Annex F clause F.4.

## 5.4.2 Minimum transmit output power

### 5.4.2.1 Definition and applicability

The minimum controlled output power of the UE is when the power control setting is set to a minimum value. This is when the uplink power control indicates a minimum transmit output power is required.

The normative requirements of this test apply to all types of UTRA- UE.

### 5.4.2.2 Minimum Requirements

The minimum transmit power shall be lower than or equal to  $-44$  dBm

The normative reference for this requirement is TS 25.102 [1] clause 6.4.5.1.

### 5.4.2.3 Test purpose

The test purpose is to verify the ability of the UE to reduce its output power to a specified value.

### 5.4.2.4 Method of test

#### 5.4.2.4.1 Initial conditions

Test environment: normal, TL/VL, TL/VH, TH/VL, TH/VH; see clauses G.2.1 and G.2.2.

Frequencies to be tested: low range, mid range, high range; see clause G.2.4.

- 1) Connect the SS to the UE antenna connector as shown in figure A.1.
- 2) A call is set up according to the Generic call setup procedure using parameters as specified in table E.3.1.2.
- 3) Enter the UE into loopback test mode and start the loopback test.

#### 5.4.2.4.2 Procedure

- 1) Configure the UE transmitter to enable power control steps of size 1 dB.
- 2) Measure power of the UE output signal over the useful part of the active time slot according to annex B.

NOTE: Annex B returns the power in the decision points (displayed as reference power and power offset). This is equivalent to thermal power at the air-interface. Insofar 5.4.2 minimum output power is consistent with 5.2 maximum output power.

- 3) Configure the UE transmitter to enable power control steps of 2 dB and of 3 dB, respectively, and repeat step 2).
- 4) Run step 2) for RF channels Low Mid and High.

### 5.4.2.5 Test requirements

For all measurements, the minimum transmit power derived in step 3) and 4) of 5.4.2.4.2 shall be below  $-43$  dBm.

NOTE: If the above Test Requirement differs from the Minimum Requirement then the Test Tolerance applied for this test is non-zero. The Test Tolerance for this test is defined in annex F clause F.2 and the explanation of how the Minimum Requirement has been relaxed by the Test Tolerance is given in annex F clause F.4.

## 5.4.3 Transmit OFF power

### 5.4.3.1 Definition and applicability

The transmit OFF power state is when the UE does not transmit. This parameter is defined as the maximum output transmit power within the channel bandwidth when the transmitter is OFF.

The requirements of this test apply to all types of UTRA-UE.

### 5.4.3.2 Minimum Requirements

The transmit OFF power shall be below  $-65$  dBm.

The normative reference for this requirement is TS 25.102 clause 6.5.1.

### 5.4.3.3 Test purpose

Refer clause 5.4.4.3.

### 5.4.3.4 Method of test

Refer clause 5.4.4.4

### 5.4.3.5 Test requirements

The transmit OFF power shall be below  $-63,5$  dBm.

**NOTE:** If the above Test Requirement differs from the Minimum Requirement then the Test Tolerance applied for this test is non-zero. The Test Tolerance for this test is defined in annex F clause F.2 and the explanation of how the Minimum Requirement has been relaxed by the Test Tolerance is given in annex F clause F.4

## 5.4.4 Transmit ON/OFF Time mask

### 5.4.4.1 Definition and applicability

The transmit ON/OFF time mask defines the ramping time allowed for the UE between transmit OFF power and transmit ON power.

This test applies for all UTRA TTD UEs.

### 5.4.4.2 Minimum requirements

The transmit power level versus time shall meet the mask specified in figure 5.4.4.2, where the transmission period refers to the burst without guard-period for a single transmission slot, and to the period from the beginning of the burst in the first transmission slot to the end of the burst without guard period in the last transmission timeslot for consecutive transmission slots.

The reference for this requirement is TS 25.102 [1] clause 6.5.2.1.

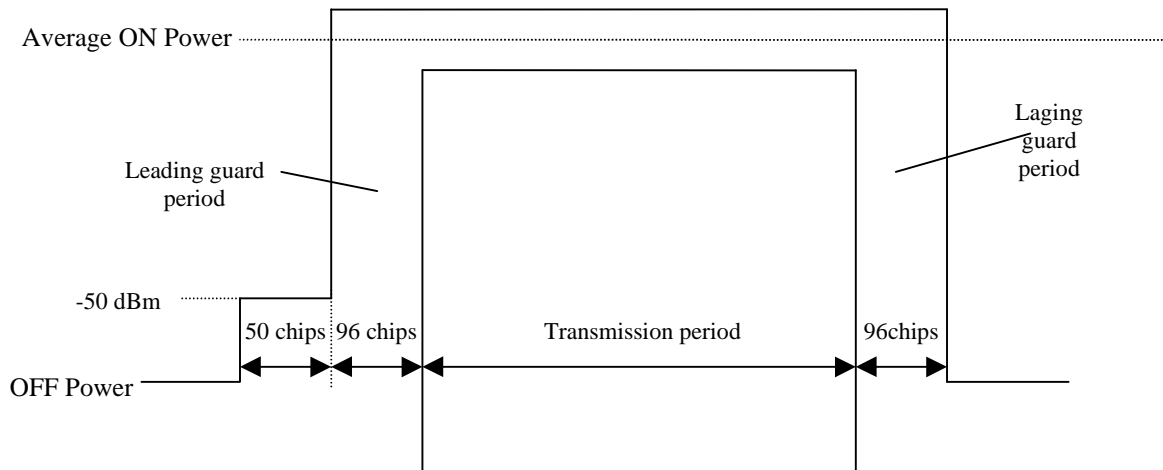

Figure 5.4.4.2: Transmit ON/OFF template

### 5.4.4.3 Test Purpose

It is tested if the UE TX signal uses the guard period for on-to-off and off-to-on transitions, where the time position of guard period is derived from the burst under test itself.

It is furtheron tested, if the UE TX signal is below certain limits outside transmission period and guard periods where the position in time is derived from the burst under test itself.

With this test interference to other UTRA TDD users are limited.

### 5.4.4.4 Method of test

#### 5.4.4.4.1 Initial conditions

Test environment: normal, TL/VL, TL/VH, TH/VL, TH/VH; see clauses G.2.1 and G.2.2.

Frequencies to be tested: low range, mid range, high range; see clause G.2.4.

Connect the SS to the UE antenna connector as shown in figure A.1.

A call is set up according to the generic call setup procedure using parameters as specified in table E.3.1.2.

Enter the UE into loopback test mode and start the loopback test.

#### 5.4.4.4.2 Procedure

- 1) The time position of the midamble of the burst under test (TimeSlot  $s$  in Frame  $f$ ) shall be the reference for the time position of the leading and laging guard-periods of the burst under test and, alternatively, for the equivalent guard periods of the next 2 bursts.
- 2) Record the following time periods with at least 2 samples /chip through a matched filter (RRC 0,22, BW equal to the chiprate): TS  $s-1$  and TS  $s+1$  in frame  $f$  or  $f+1$  or  $f+2$
- 3) Calculate power samples by averaging the recorded samples of one chip duration.

### 5.4.4.5 Test requirements

Each power sample shall be below the limits (off Power (clause 5.4.3) and  $-50$  dBm), indicated in figure 5.4.4.2.

NOTE: In this test no power limits apply during guard period.

## 5.4.5 Out-of-synchronisation handling of output power

### 5.4.5.1 Definition and applicability

The UE shall monitor the DPCH quality in order to detect a loss of the signal on Layer 1, as specified in TS 25.224. [5] The thresholds  $Q_{out}$  and  $Q_{in}$  specify at what DPCH quality levels the UE shall shut its power off and when it shall turn its power on, respectively. The thresholds are not defined explicitly, but are defined by the conditions under which the UE shall shut its transmitter off and turn it on, as stated in this clause.

The requirement of this clause shall apply to all types of UTRA-UE.

### 5.4.5.2 Minimum Requirement

When the UE estimates the DPCH quality over the last 160 ms period to be worse than a threshold  $Q_{out}$ , the UE shall shut its transmitter off within 40 ms. The UE shall not turn its transmitter on again until the DPCH quality exceeds an acceptable level  $Q_{in}$ . When the UE estimates the DPCH quality over the last 160 ms period to be better than a threshold  $Q_{in}$ , the UE shall again turn its transmitter on within 40 ms.

The quality levels at the thresholds  $Q_{out}$  and  $Q_{in}$  correspond to different signal levels depending on the downlink conditions DCH parameters. For the conditions in Table 5.4.5.1.a, a signal with the quality at the level  $Q_{out}$  is generated by a  $\Sigma DPCH\_Ec/I_{or}$  ratio of -13 dB, and a signal with  $Q_{in}$  by a  $\Sigma DPCH\_Ec/I_{or}$  ratio of -9 dB. In this test, the DL reference measurement channel (12.2) kbps specified in clause C.3.1, where the CRC bits are replaced by data bits, and with static propagation conditions is used.

**Table 5.4.5.1: DCH parameters for the Out-of-synch handling test case**

Parameter	Unit	Value
$\hat{I}_{or}/I_{oc}$	dB	-1
$I_{oc}$	dBm/3,84 MHz	-60
$\frac{\Sigma DPCH\_Ec}{I_{or}}$	dB	See figure 5.4.5.1
Information Data Rate	kbps	13
TFCI	-	On

The conditions for when the UE shall shut its transmitter off and when it shall turn it on are defined by the parameters in table 5.4.5.1 together with the DPCH power level as defined in figure 5.4.5.1.



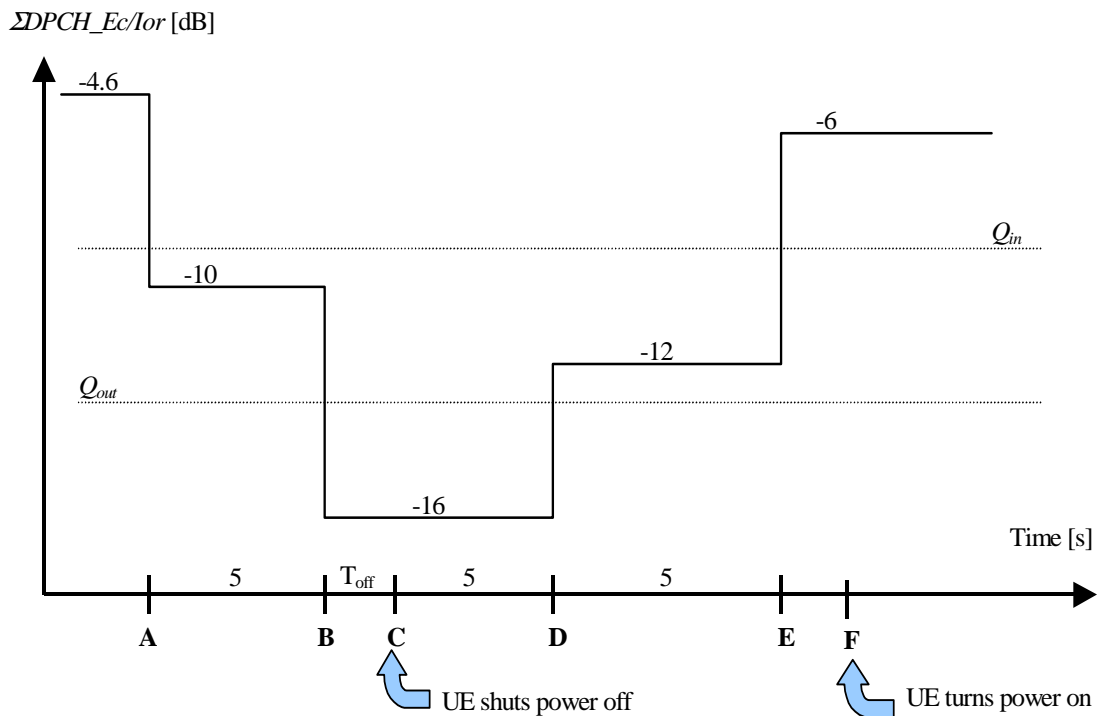

**Figure 5.4.5.1: Test case for out-of-synch handling in the UE.**

The requirements for the UE are that:

- 1) The UE shall not shut its transmitter off before point B.
- 2) The UE shall shut its transmitter off before point C, which is  $T_{off} = 200$  ms after point B
- 3) The UE shall not turn its transmitter on between points C and E.
- 4) The UE shall turn its transmitter on before point F, which is  $T_{on} = 200$  ms after Point E.

The normative reference for this test is TS 25.102 [1] clause 6.4.3.

### 5.4.5.3 Test purpose

To verify that the UE monitors the DPCH quality and turns its transmitter on or off according to DPCH level diagram specified in figure 5.4.5.1.

### 5.4.5.4 Method of test

#### 5.4.5.4.1 Initial conditions

Test environment: normal; see clauses G.2.1 and G.2.2.

Frequencies to be tested: mid range; see clause G.2.4.

- 1) Connect the SS to the UE antenna connector as shown in figure A.1.
- 2) Calls are set up according to the Generic call setup procedure using parameters as specified in table 5.4.5.1
- 3) Enter the UE into loopback test mode and start the loopback test.

#### 5.4.5.4.2 Procedure

- 1) SS level and signalling values are set that the UE transmits maximum power (see annex E clause E.3.1)

2) Set the SS TX signal quality to  $\frac{\Sigma DPCH - E_c}{I_{or}} = -4.6+0,4$  dB and verify that the UE TX signal is on.

3) Set the SS TX signal quality to  $\frac{\Sigma DPCH - E_c}{I_{or}} = -10+0,4$  dB and verify that the UE TX signal remains on continuously for at least 5 seconds.

4) Set the SS TX signal quality to  $\frac{\Sigma DPCH - E_c}{I_{or}} = -16-0,4$  dB and verify that the UE TX signal turns off 200 ms or earlier with respect to that instant.

5) Set the SS TX signal quality to  $\frac{\Sigma DPCH - E_c}{I_{or}} = -12-0,4$  dB and verify that the UE TX signal remains off continuously for at least 5 seconds.

6) Set the SS TX signal quality to  $\frac{\Sigma DPCH - E_c}{I_{or}} = -6+0,4$  dB and verify that the UE TX signal is switched on 200 ms or earlier with respect to that instant.

#### 5.4.5.5 Test Requirements

The UE TX on-criterion including tolerance window is derived from the initial conditions and is verified with the method of 5.4.2 minimum transmit power. The UE transmitter is considered to be on if the UE transmitted power is higher than the minimum output power.

The UE TX off criterion including tolerance is verified according to clause 5.4.3 of the present document (Transmit off power). The UE transmitter is considered to be off if the UE transmitted power is lower than the transmit OFF power.

To pass the test, steps 1 through 6 of the procedure must be fulfilled.

## 5.5 Output RF spectrum emissions

### 5.5.1 Occupied bandwidth

#### 5.5.1.1 Definition and applicability

Occupied bandwidth is a measure of the bandwidth containing 99 % of the total integrated power for transmitted spectrum and is centered on the assigned channel frequency.

The requirements in this clause shall apply to all types of UTRA - UE.

#### 5.5.1.2 Minimum Requirements

The occupied bandwidth shall be less than 5 MHz based on a chip rate of 3,84 Mcps.

The normative reference for this requirement is TS 25.102 [1] clause 6.6.1.

### 5.5.1.3 Test purpose

The occupied bandwidth, defined in the Radio Regulations of the International Telecommunication Union ITU, is a useful concept for specifying the spectral properties of a given emission in the simplest possible manner; see also ITU-R Recommendation SM.328-9 [8].

The test purpose is to verify that the emission of the UE is sufficiently concentrated in the bandwidth for the service to be provided and is, therefore, not likely to create interference to other users of the spectrum beyond undue limits.

### 5.5.1.4 Method of test

#### 5.5.1.4.1 Initial conditions

Test environment: normal; see clauses G.2.1 and G.2.2.

Frequencies to be tested: low range, mid range, high range; see clause G.2.4.

- 1) Connect the SS to the UE antenna connector as shown in figure A.1.
- 2) A call is set up according to the generic call setup procedure using parameters as specified in table E.3.1.2.
- 3) Enter the UE into loopback test mode and start the loopback test.

#### 5.5.1.4.2 Procedure

- 1) Measure the power of the transmitted signal with a measurement filter of bandwidth [30 kHz]. The characteristic of the filter shall be approximately Gaussian (typical spectrum analyzer filter). The center frequency of the filter shall be stepped in contiguous 30 kHz steps from a minimum frequency, which shall be [7,5 – 0,015] MHz below the assigned channel frequency of the transmitted signal, up to a maximum frequency, which shall be [7,5 – 0,015] MHz above the assigned channel frequency of the transmitted signal. The step duration shall be sufficient slow to capture the active TS. The measured power shall be recorded for each step.
- 2) Determine the total transmitted power by accumulating the recorded power measurements results of all steps.
- 3) Sum up the power upward from the lower boundary of the measured frequency range in '(2)' and seek the limit frequency point by which this sum becomes 0,5 % of "Total Power" and save this point as "Lower Frequency".
- 4) Sum up the power downward from the upper boundary of the measured frequency range in '(2)' and seek the limit frequency point by which this sum becomes 0,5 % of "Total Power" and save this point as "Upper Frequency".
- 5) Calculate the difference ("Upper Frequency" – "Lower Frequency" = "Occupied Bandwidth") between two limit frequencies obtained in '(4)' and '(5)'.

### 5.5.1.5 Test requirements

The measured Occupied Bandwidth, derived in step 5), shall not exceed 5 MHz.

NOTE: If the above Test Requirement differs from the Minimum Requirement then the Test Tolerance applied for this test is non-zero. The Test Tolerance for this test is defined in annex F clause F.2 and the explanation of how the Minimum Requirement has been relaxed by the Test Tolerance is given in annex F clause F.4.

## 5.5.2 Out of band emission

Out of band emissions are unwanted emissions immediately outside the nominal channel resulting from the modulation process and non-linearity in the transmitter but excluding spurious emissions. This out of band emission limit is specified in terms of a spectrum emission mask and adjacent channel power ratio.

### 5.5.2.1 Spectrum emission mask

#### 5.5.2.1.1 Definition and applicability

The spectrum emission mask of the UE is a requirement that applies to frequencies which are between 2,5 and 12,5MHz to both sides of the carrier frequency. The out of channel emission is specified relative to the UE output power in a 3,84 MHz bandwidth.

The requirements of this test apply to all types of UTRA-UE.

#### 5.5.2.1.2 Minimum Requirements

The power of any UE emission shall not exceed the levels specified in table 5.5.2.1.2.

The normative reference for this requirement is TS 25.102 clause 6.6.2.1.1

**Table 5.5.2.1.2: Spectrum Emission Mask Requirement**

Frequency offset from carrier $\Delta f$	Minimum requirement	Measurement bandwidth
2.5 - 3.5 MHz	$-35 - 15 \cdot (\Delta f - 2.5)$ dBc	30 kHz
3.5 - 7.5 MHz	$-35 - 1 \cdot (\Delta f - 3.5)$ dBc	1 MHz
7.5 - 8.5 MHz	$-39 - 10 \cdot (\Delta f - 7.5)$ dBc	1 MHz
8.5 - 12.5 MHz	-49 dBc	1 MHz

NOTE 1: The first and last measurement position with a 30 kHz filter is 2,515 MHz and 3,485 MHz.

NOTE 2: The first and last measurement position with a 1 MHz filter is 4 MHz and 12 MHz.

NOTE 3: The lower limit shall be  $-50\text{dBm}/3,84\text{ MHz}$  or which ever is higher.

#### 5.5.2.1.3 Test purpose

This test supplements Occupied Bandwidth (verifying the spectral concentration of the UE's emissions) and Adjacent Channel Leakage Ratio (simulating the perception of other UTRA receivers) in a system independent way. It is the purpose of this test to limit interferences to other systems (wideband or narrowband).

#### 5.5.2.1.4 Method of test

##### 5.5.2.1.4.1 Initial conditions

Test environment: normal; see clauses G.2.1 and G.2.2.

Frequencies to be tested: low range, high range; see clause G.2.4.

- 1) Connect the SS to the UE antenna connector as shown in figure A.1.
- 2) A call is set up according to the generic call setup procedure using parameters as specified in table E.3.1.2.
- 3) Enter the UE into loopback test mode and start the loopback test.

##### 5.5.2.1.4.2 Procedure

- 1) Measure the power of the transmitted signal with a measurement filter of bandwidths according to table 5.5.2.1.2. The characteristic of the filter shall be approximately Gaussian (typical spectrum analyzer filter).

The center frequency of the filter shall be stepped in contiguous steps according to table 5.5.2.1.2. The step duration shall be sufficient slow to capture the active TS. The measured power shall be recorded for each step.

- 2) Measure the wanted output power according to annex B.
- 3) Display the results of 1) in dBc with respect to 2).

### 5.5.2.1.5 Test requirements

The result 5.5.2.1.4.2 step 3) shall fulfil the requirements of table 5.5.2.1.5.

**Table 5.5.2.1.5: Spectrum Emission Mask Requirement**

Frequency offset from carrier $\Delta f$	Minimum requirement	Measurement bandwidth
2.5 - 3.5 MHz	$-33.5 - 15 \cdot (\Delta f - 2.5)$ dBc	30 kHz
3.5 - 7.5 MHz	$-33.5 - 1 \cdot (\Delta f - 3.5)$ dBc	1 MHz
7.5 - 8.5 MHz	$-37.5 - 10 \cdot (\Delta f - 7.5)$ dBc	1 MHz
8.5 - 12.5 MHz	-47.5 dBc	1 MHz

NOTE 1. The first and last measurement position with a 30 kHz filter is 2.515 MHz and 3.485 MHz.

NOTE 2. The first and last measurement position with a 1 MHz filter is 4 MHz and 12 MHz.

NOTE 3. The lower limit shall be  $-48,5$  dBm/3,84 MHz or which ever is higher

NOTE 4: If the above Test Requirement differs from the Minimum Requirement then the Test Tolerance applied for this test is non-zero. The Test Tolerance for this test is defined in annex F clause F.2 and the explanation of how the Minimum Requirement has been relaxed by the Test Tolerance is given in annex F clause F.4.

## 5.5.2.2 Adjacent Channel Leakage power Ratio (ACLR)

### 5.5.2.2.1 Definition and applicability

Adjacent Channel Leakage power Ratio (ACLR) is the ratio of the wanted power to the power in an adjacent channel. Both the wanted power and adjacent channel power are measured with a Root-Raised Cosine (RRC) filter with roll-off  $\alpha = 0,22$  and a bandwidth equal to the chip rate.

The requirements in this clause shall apply to all types of UTRA-UE.

### 5.5.2.2.2 Minimum Requirements

If the adjacent channel power is greater than  $-50$  dBm then the ACLR shall be better than the value specified in table 5.5.2.2.2.

The normative reference for this requirement is TS 25.102 [1] clause 6.6.2.2.1

**Table 5.5.2.2.2: UE ACLR**

Power Class	Adjacent channel	ACLR limit
2, 3	UE-channel $\pm 5$ MHz	-33 dB
2, 3	UE-Channel $\pm 10$ MHz	-43 dB

### 5.5.2.2.3 Test purpose

The test purpose is to verify the ability of the UE to limit the interference produced by the transmitted signal to other UTRA receivers operating at the first or second adjacent RF channel.

#### 5.5.2.2.4 Method of test

##### 5.5.2.2.4.1 Initial conditions

Test environment: normal, TL/VL, TL/VH, TH/VL, TH/VH; see clauses G.2.1 and G.2.2.

Frequencies to be tested: low range, mid range, high range; see clause G.2.4.

- 1) Connect the SS to the UE antenna connector as shown in figure A.1.
- 2) A call is set up according to the generic call setup procedure using parameters as specified in table E.3.1.2.
- 3) Enter the UE into loopback test mode and start the loopback test.

##### 5.5.2.2.4.2 Procedure

- 1) Measure the wanted transmitted power of the active timeslot using the method in annex B.
- 2) Average over TBD time slots.
- 3) Measure interference power at the first lower adjacent RF channel (center frequency 5 MHz below the assigned channel frequency of the transmitted signal) over the useful part of the active TS with a measurement filter that has a RRC filter response with a roll off  $\alpha = 0,22$  and a bandwidth equal to the chip rate.
- 4) Average over TBD time slots.
- 5) Calculate the ACLR by  
Transmitted power acc. to 2) / interference power acc. to 4).
- 6) Repeat steps 3), 4) and 5) for the second lower adjacent RF channel (center frequency 10 MHz below the assigned channel frequency of the transmitted signal) and also for the first and second upper adjacent RF channel (center frequency 5 MHz and 10 MHz, respectively).

#### 5.5.2.2.5 Test requirements

The ACLR calculated in steps 5) and 6) of clause 5.5.2.2.4.2 shall be equal or greater than the limits given in table 5.5.2.2.5.

**Table 5.5.2.2.5: UE ACLR**

Power Class	Adjacent channel	ACLR limit
2, 3	UE-channel $\pm 5$ MHz	-32.2 dB
2, 3	UE-Channel $\pm 10$ MHz	-42.2 dB

NOTE: If the above Test Requirement differs from the Minimum Requirement then the Test Tolerance applied for this test is non-zero. The Test Tolerance for this test is defined in annex F clause F.2 and the explanation of how the Minimum Requirement has been relaxed by the Test Tolerance is given in annex F.

### 5.5.3 Spurious emissions

#### 5.5.3.1 Definition and applicability

Spurious emissions are emissions which are caused by unwanted transmitter effects such as harmonics emission, parasitic emission, intermodulation products and frequency conversion products, but exclude out of band emissions.

The frequency boundary and the detailed transitions of the limits between the requirement for out band emissions and spectrum emissions are based on ITU-R Recommendations SM.329 [8].

### 5.5.3.2 Minimum Requirements

These requirements are only applicable for frequencies which are greater than 12.5 MHz away from the UE center carrier frequency.

The normative reference for this requirement is TS 25.102 [1] clause 6.6.3.1.

**Table 5.5.3.2a: General Spurious emissions requirements**

Frequency Bandwidth	Resolution Bandwidth	Minimum requirement
$9 \text{ kHz} \leq f < 150 \text{ kHz}$	1 kHz	-36 dBm
$150 \text{ kHz} \leq f < 30 \text{ MHz}$	10 kHz	-36 dBm
$30 \text{ MHz} \leq f < 1000 \text{ MHz}$	100 kHz	-36 dBm
$1 \text{ GHz} \leq f < 12,75 \text{ GHz}$	1 MHz	-30 dBm

**Table 5.5.3.2b: Additional Spurious emissions requirements**

Frequency Bandwidth	Resolution Bandwidth	Minimum requirement
$925 \text{ MHz} \leq f \leq 935 \text{ MHz}$	100 kHz	-67 dBm*
$935 \text{ MHz} < f \leq 960 \text{ MHz}$	100 kHz	-79 dBm*
$1805 \text{ MHz} \leq f \leq 1880 \text{ MHz}$	100 kHz	-71 dBm*

NOTE: The measurements are made on frequencies which are integer multiples of 200 kHz. As exceptions, up to five measurements with a level up to the applicable requirements defined in table 5.5.3.2b are permitted for each UARFCN used in the measurement.

### 5.5.3.3 Test purpose

The test purpose is to verify the ability of the UE to limit the interference caused by unwanted transmitter effects to other systems operating at frequencies which are more than 12,5 MHz away from of the UE's carrier frequency.

### 5.5.3.4 Method of test

#### 5.5.3.4.1 Initial conditions

Test environment: normal; see clauses G.2.1 and G.2.2.

Frequencies to be tested: low range, mid range, high range; see clause G.2.4.

- 1) Connect the SS to the UE antenna connector as shown in figure A.1.
- 2) A call is set up according to the generic call setup procedure using parameters as specified in table E.3.1.2.
- 3) Enter the UE into loopback test mode and start the loopback test.

#### 5.5.3.4.2 Procedure

Measure the power of the spurious emissions applying measurement filters with bandwidths as specified in the relevant tables of 5.5.3.2. The characteristic of the filters shall be approximately Gaussian (typical spectrum analyzer filters). The center frequency of the filter shall be swept over the frequency bands as given in the tables. The sweep time shall be sufficiently low to capture the active time slots.

### 5.5.3.5 Test requirements

The spurious emissions measured according to clause 5.5.3.4.2 shall not exceed the limits specified in the relevant tables of 5.5.3.5.a and 5.5.3.5.b.

**Table 5.5.3.5a: General Spurious emissions requirements**

Frequency Bandwidth	Resolution Bandwidth	Test requirement
$9 \text{ kHz} \leq f < 150 \text{ kHz}$	1 kHz	-36 dBm
$150 \text{ kHz} \leq f < 30 \text{ MHz}$	10 kHz	-36 dBm
$30 \text{ MHz} \leq f < 1000 \text{ MHz}$	100 kHz	-36 dBm
$1 \text{ GHz} \leq f < 12.75 \text{ GHz}$	1 MHz	-30 dBm

**Table 5.5.3.5b: Additional Spurious emissions requirements**

Frequency Bandwidth	Resolution Bandwidth	Test requirement
$925 \text{ MHz} \leq f \leq 935 \text{ MHz}$	100 kHz	-67 dBm*
$935 \text{ MHz} < f \leq 960 \text{ MHz}$	100 kHz	-79 dBm*
$1805 \text{ MHz} \leq f \leq 1880 \text{ MHz}$	100 kHz	-71 dBm*

NOTE 1: The measurements are made on frequencies which are integer multiples of 200 kHz. As exceptions, up to five measurements with a level up to the applicable requirements defined in table 5.5.3.5b are permitted for each UARFCN used in the measurement.

NOTE 2: If the above Test Requirement differs from the Minimum Requirement then the Test Tolerance applied for this test is non-zero. The Test Tolerance for this test is defined in annex F clause F.2 and the explanation of how the Minimum Requirement has been relaxed by the Test Tolerance is given in annex F clause F.4.

## 5.6 Transmit Intermodulation

### 5.6.1 Definition and applicability

The transmit intermodulation performance is a measure of the capability of the transmitter to inhibit the generation of signals in its non linear elements caused by the presence of the wanted signal and an interfering signal reaching the transmitter via the antenna.

The UE intermodulation attenuation is defined by the ratio of the output power of the wanted signal to the output power of the intermodulation product when an interfering CW signal is added at a level below the wanted signal. Both the wanted signal power and the intermodulation product power are measured with a filter response that is root-raised cosine (RRC) with roll-off  $\alpha=0,22$  and with a bandwidth equal to the chip rate.

The requirements of this test shall apply for all UTRA-UE.

### 5.6.2 Minimum Requirements

The requirement of transmitting intermodulation for carrier spacing 5 MHz is prescribed in the table below.

The normative reference for this requirement is TS 25.102 [1] clause 6.7.1

**Table 5.6.2: Transmit Intermodulation**

Interference Signal Frequency Offset	5MHz	10MHz
Interference Signal Level	-40 dBc	
Interferer Modulation	CW Note: BS Test uses a CDMA modulated signal	
Minimum requirement	-31dBc	-41dBc



### 5.6.3 Test purpose

User Equipment(s) transmitting in close vicinity of each other can produce intermodulation products, which can fall into other UE, or BS receive band as an unwanted interfering signal.

It is the purpose of this test to limit interferences to the own and other systems due to intermodulation products.

### 5.6.4 Method of test

#### 5.6.4.1 Initial conditions

Test environment: normal; see clauses G.2.1 and G.2.2.

Frequencies to be tested: mid range; see clause G.2.4.

- 1) Connect the SS and the interferer to the UE antenna connector as shown in figure A.2.
- 2) A call is set up according to the generic call setup procedure using parameters as specified in table E.3.1.2.
- 3) Enter the UE into loopback test mode and start the loopback test.

Parameters of the interferer according to table 5.6.2.

#### 5.6.4.2 Procedure

- 1) Measure the unwanted emissions according to 5.6.2. in a carrier offset spacing of 5 MHz and in a frequency range [5 MHz to 12.75 GHz], using an interferer +5MHz offset.

The frequency occupied by the interferer is excluded from the measurement.

- 2) Repeat 1) with the other 3 interferer-configurations (-5MHz, +10 MHz, -10 MHz).
- 3) Measure the wanted power according to annex B.
- 4) Display 1) and 2) in dBc with respect to 3).

### 5.6.5 Test requirements

The results in 4) from clause 5.6.4.2 shall not exceed the prescribed values in table 5.6.5.

**Table 5.6.5: Transmit Intermodulation**

Interference Signal Frequency Offset	5MHz	10MHz
Interference Signal Level	-40 dBc	
Interferer Modulation	CW Note: BS Test uses a CDMA modulated signal	
Minimum requirement	[-31+TT] dBc	[-41+TT] dBc

NOTE: If the above Test Requirement differs from the Minimum Requirement then the Test Tolerance applied for this test is non-zero. The Test Tolerance for this test is defined in annex F clause F.2 and the explanation of how the Minimum Requirement has been relaxed by the Test Tolerance is given in annex F clause F.4.

## 5.7 Transmit Modulation

### 5.7.1 Error Vector Magnitude

#### 5.7.1.1 Definition and applicability

The Error Vector Magnitude (EVM) is a measure of the difference between the measured waveform and the theoretical modulated waveform (the error vector). It is the square root of the ratio of the mean error vector power to the mean reference signal power expressed as a %. The measurement interval is one timeslot.

The requirement of this clause shall apply to all types of UTRA-UE.

#### 5.7.1.2 Minimum Requirements

The Error Vector Magnitude shall not exceed 17,5 % for the parameters specified in table 5.7.2.1.

**Table 5.7.1.2: Test parameters for Error Vector Magnitude/Peak Code Domain Error**

Parameter	Level	Unit
UE Output Power	$\geq -20$	dBm
Operating conditions	Normal conditions	
Power control step size	1	dB

The normative reference for this requirement is TS 25.102 [1] clause 6.8.2.

#### 5.7.1.3 Test purpose

The transmitter shall generate a sufficient precise waveform, to enable the receiver to achieve the specified receiver performances.

#### 5.7.1.4 Method of test

##### 5.7.1.4.1 Initial conditions

Test environment: normal, TL/VL, TL/VH, TH/VL, TH/VH, vibration; see clauses G.2.1, G.2.2 and G.2.3.

Frequencies to be tested: low range, mid range, high range; see clause G.2.4.

- 1) Connect the SS to the UE antenna connector as shown in figure A.1.
- 2) A call is set up according to the generic call setup procedure using parameters as specified in table E.3.1.2.
- 3) Enter the UE into loopback test mode and start the loopback test.

##### 5.7.1.4.2 Procedure

- 1) Starting from the initial conditions, measure EVM (Error Vector Magnitude) of the UE according to annex B.
- 2) Set SS-level and signalling values such that the power level of the UE is between  $-20$  and  $-19$  dBm.
- 3) Measure EVM of the UE according to annex B.

#### 5.7.1.5 Test requirements

The results in step 1) and 2) shall not exceed 17,5 % for parameters specified in table 5.7.1.2.

NOTE: If the above Test Requirement differs from the Minimum Requirement then the Test Tolerance applied for this test is non-zero. The Test Tolerance for this test is defined in annex F clause F.2 and the explanation of how the Minimum Requirement has been relaxed by the Test Tolerance is given in annex F clause F.4.

## 5.7.2 Peak code domain error

### 5.7.2.1 Definition and applicability

The code domain error is computed by projecting the error vector power onto the code domain at a specific spreading factor. The error power for each code is defined as the ratio to the mean power of the projection onto the code, to the mean power of the composite reference waveform expressed in dB. And the Peak Code Domain Error is defined as the maximum value for Code Domain Error. The measurement interval is one timeslot.

The present document is applicable for multi-code transmission only.

The requirement of this test applies to all UTRA-UE, applicable for multi-code transmission.

### 5.7.2.2 Minimum Requirement

The peak code domain error shall not exceed -21dB at spreading factor 16.

The normative reference for this requirement is TS 25.102 [1] clause 6.8.3.1.

### 5.7.2.3 Test purpose

It is the purpose of this test to limit crosstalk among codes.

### 5.7.2.4 Method of test

#### 5.7.2.4.1 Initial conditions

Test environment: normal, TL/VL, TL/VH, TH/VL, TH/VH; see clauses G.2.1 and G.2.2.

Frequencies to be tested: low range, mid range, high range; see clause G.2.4.

- 1) Connect the SS to the UE antenna connector as shown in figure A.1.
- 2) A call is set up according to the generic call setup procedure using parameters as specified in table 5.7.2.4.1.
- 3) Enter the UE into loopback test mode and start the loopback test.

**Table 5.7.2.4.1: Test parameters for Peak code Domain Error**

Parameter	Value/description
Reference measurement channel	Multicode 12,2kbps, according to annex C.2.2
Uplink Power Control	SS level and signalling values such that UE transmits maximum power
Data content	real life (sufficient irregular)

#### 5.7.2.4.2 Procedure

- 1) Starting from the initial conditions, measure peak code error(PCDE)of the UE according to annex B.
- 2) Set SS-level and signalling values such that the power level of the UE is between -20 and -19 dBm
- 3) Measure PCDE of the UE according to annex B.

### 5.7.2.5 Test requirements

The results in step 1) and 2) shall not exceed -20 dB. for parameters specified in table 5.7.1.2.

NOTE: If the above Test Requirement differs from the Minimum Requirement then the Test Tolerance applied for this test is non-zero. The Test Tolerance for this test is defined in annex F clause F.2 and the explanation of how the Minimum Requirement has been relaxed by the Test Tolerance is given in annex F clause F.4.

## 6 Receiver Characteristics

### 6.1 General

Receiving performance test of the UE is implemented during communicating with the SS via air interface. The procedure uses normal call protocol until the UE is communicating on traffic channel basically. (Refer to TS 34.108 [3] Common Test Environments for User Equipment (UE) Conformance Testing.) On the traffic channel, the UE provides special function for testing that is described in Logical Test Interface and the UE is tested using this function. (Refer to TS 34.109 [3] Logical Test Interface (FDD/TDD) Special conformance testing functions.)

Unless otherwise stated the receiver characteristics are specified at the antenna connector of the UE. For UE(s) with an integral antenna only, a reference antenna with a gain of 0 dBi is assumed. UE with an integral antenna may be taken into account by converting these power levels into field strength requirements, assuming a 0 dBi gain antenna. Receiver characteristics for UE(s) with multiple antennas/antenna connectors are for further study.

The UE antenna performance has a significant impact on system performance, and minimum requirements on the antenna efficiency are therefore intended to be included in future versions of the present document. It is recognized that different requirements and test methods are likely to be required for the different types of UE.

All the parameters in clause 6 are defined using the DL reference measurement channel (12.2 kbps) specified in clause C.3.3.

### 6.2 Reference sensitivity level

#### 6.2.1 Definition and applicability

The reference sensitivity is the minimum receiver input power measured at the antenna connector at which the BER does not exceed the specific value.

The requirements in this clause shall apply to all types of UTRA UE.

#### 6.2.2 Minimum Requirements

For the DL reference measurement channel 12.2 kBit/s specified in annex C, the BER shall not exceed 0.001 for the parameters specified in table 6.2.2.

**Table 6.2.2. Test parameters for reference sensitivity**

Parameter	Level	Unit
$\frac{\Sigma DPCH_{Ec}}{I_{or}}$	0	dB
$\hat{I}_{or}$	-105	dBm/3,84 MHz

The normative reference for this requirement is TS 25.102 [1] clause 7.3.

## 6.2.3 Test purpose

The test purpose is to verify the ability of the UE to receive a prescribed test signal at the lower end of the dynamic range under defined conditions (no interference, no multipath propagation) with a BER not exceeding a specified level. This test is also used as a reference case for other tests to allow the assessment of degradations due to various sources of interference.

## 6.2.4 Method of test

### 6.2.4.1 Initial conditions

Test environment: normal, TL/VL, TL/VH, TH/VL, TH/VH; see clauses G.2.1 and G.2.2.

Frequencies to be tested: low range, mid range, high range; see clause G.2.4.

- 1) Connect the SS to the UE antenna connector as shown in figure A.3.
- 2) A call is set up according to the Generic call setup procedure.
- 3) Enter the UE into loopback test mode and start the loopback test.
- 4) The level of SS output signal measured at the UE antenna connector shall be  $-105$  dBm.

### 6.2.4.2 Procedure

- 1) Measure the BER of DCH received from the UE at the SS.

## 6.2.5 Test requirements

The measured BER, derived in step 1), shall not exceed 0,001 under conditions described in table 6.2.5.

**Table 6.2.5: Test parameters for reference sensitivity**

Parameter	Level	Unit
$\frac{\Sigma DPCH_{Ec}}{I_{or}}$	0	dB
$\hat{I}_{or}$	-104.3	dBm/3,84 MHz

NOTE: If the above Test Requirement differs from the Minimum Requirement then the Test Tolerance applied for this test is non-zero. The Test Tolerance for this test is defined in annex F clause F.2 and the explanation of how the Minimum Requirement has been relaxed by the Test Tolerance is given in annex F clause F.4.

## 6.3 Maximum Input Level

### 6.3.1 Definition and applicability

This is defined as the maximum receiver input power, measured at the antenna connector, which does not degrade the specified BER performance.

The requirements in this clause shall apply to all types of UTRA UE.

### 6.3.2 Minimum requirements

The BER shall not exceed 0,001 for the parameters specified in table 6.3.2.

**Table 6.3.2: Maximum input level**

Parameter	Level	Unit
$\frac{\Sigma DPCH\_Ec}{I_{or}}$	-7	dB
$\hat{I}_{or}$	-25	dBm/3,84 MHz

The reference for this requirement is TS 25.102 [1] clause 7.4.

### 6.3.3 Test purpose

The test purpose is to verify the ability of the UE to receive a prescribed test signal at the upper end of the dynamic range under defined conditions (no interference, no multipath propagation) with BER not exceeding a specified value.

### 6.3.4 Method of test

#### 6.3.4.1 Initial conditions

Test environment: normal; see clauses G.2.1 and G.2.2.

Frequencies to be tested: mid range; see clause G.2.4.

- 1) Connect the SS to the UE antenna connector as shown in figure A.3.
- 2) A call is set up according to the Generic call setup procedure.
- 3) Enter the UE into loopback test mode and start the loopback test.
- 4) The level of SS output signal measured at the UE antenna connector shall be according to table 6.3.2.

#### 6.3.4.2 Procedure

Measure the BER of DCH received from the UE at the SS.

### 6.3.5 Test requirements

The measured BER, derived in step 1), shall not exceed 0,001.

## 6.4 Adjacent Channel Selectivity (ACS)

### 6.4.1 Definition and applicability

Adjacent Channel Selectivity is a measure of a receiver's ability to receive a wanted signal at its assigned channel frequency in the presence of an adjacent channel signal.

The requirements of this test apply to all UTRA UE.

### 6.4.2 Minimum Requirements

For the UE of power class 2 and 3, the BER shall not exceed 0,001 for parameters specified in table 6.4.2. This test condition is equivalent to the ACS value 33 dB.

**Table 6.4.2: Test parameters for Adjacent Channel Selectivity**

Parameter	Unit	Level
$\frac{\Sigma DPCCH - Ec}{I_{or}}$	dB	0
$I_{or}$	dBm/3,84 MHz	-91
$I_{oac}$	dBm/3,84 MHz	-52
$F_{uw}$ offset	MHz	+5 or -5

Explanatory note:

Within the reference sensitivity BER= 0.001 corresponds to a test signal = -105 dBm/3,84 MHz and a noise level -99 dBm /3,84 MHz BW (S/I -6 dB).

Within ACS BER=0.001 is directly verified.

Known from the reference sensitivity, this corresponds to S/I -6dB in the wanted BW.

As a wanted signal of -91 dBm applied, an in-channel-interfering-signal of -85 dBm can be assumed.

Verifying a filter suppression of 33 dB indirectly, an adjacent-channel-interferer of -52 dBm is needed

The normative reference of this requirement is TS 25.102 [1] clause 7.5.

### 6.4.3 Test purpose

The test purpose is to verify the ability of the UE-receiver to sufficiently suppress the interfering signal in the channel adjacent to the wanted channel.

### 6.4.4 Method of test

#### 6.4.4.1 Initial conditions

Test environment: normal; see clauses G.2.1 and G.2.2.

Frequencies to be tested: mid range; see clause G.2.4.

- 1) Connect the SS and the interferer to the UE antenna connector as shown in figure A.4.
- 2) A call is set up according to the Generic call setup procedure.
- 3) Enter the UE into loopback test mode and start the loopback test.
- 4) Set the signal generator to produce an interference signal. The interference signal shall be equivalent to a continuously running wideband CDMA signal with one code and chip frequency 3,84 Mchip/s and rolloff 0,22.

#### 6.4.4.2 Procedure

- 1) Set the interference signal 5 MHz above the assigned channel frequency of the wanted signal.
- 2) Measure the BER of the wanted signal received from the UE at the SS.
- 3) Set the interference signal 5 MHz below the assigned channel frequency of the wanted signal and repeat 2).

### 6.4.5 Test Requirements

The measured BER, derived in step 2), shall not exceed 0,001 under conditions described in table 6.4.5.

**Table 6.4.5: Test parameters for Adjacent Channel Selectivity**

Parameter	Unit	Level
$\frac{\Sigma DPCH\_Ec}{I_{or}}$	dB	0
$\bar{I}_{or}$	dBm/3,84 MHz	-91
$I_{oac}$	dBm/3,84 MHz	-52
$F_{uw}$ offset	MHz	+5 or -5

NOTE: If the above Test Requirement differs from the Minimum Requirement then the Test Tolerance applied for this test is non-zero. The Test Tolerance for this test is defined in annex F clause F.2 and the explanation of how the Minimum Requirement has been relaxed by the Test Tolerance is given in annex F clause F.4.

## 6.5 Blocking Characteristics

### 6.5.1 Definition and applicability

The blocking characteristics is a measure of the receiver ability to receive a wanted signal at its assigned channel frequency in the presence of an unwanted interferer on frequencies other than those of the spurious response or the adjacent channels without this unwanted input signal causing a degradation of the performance of the receiver beyond a specified limit. The blocking performance shall apply at all frequencies except those at which a spurious response occur.

The requirements of this test apply to all UTRA UE.

### 6.5.2 Minimum Requirements

The BER shall not exceed 0,001 for the parameters specified in table 6.5.2a and table 6.5.2b. For table 6.5.2b up to 24 exceptions are allowed for spurious response frequencies in each assigned frequency channel when measured using a 1MHz step size for the interference signal.

The normative reference for this requirement is TS 25.102 clause 7.6.1.

**Table 6.5.2a: In-band blocking**

Parameter	Offset 1	Offset 2	Unit
$\frac{\Sigma DPCH\_Ec}{I_{or}}$	0	0	dB
$\bar{I}_{or}$	<REFSENS> + 3 dB	<REFSENS> + 3 dB	dBm/3,84 MHz
$I_{blocking}$ (modulated)	-56	-44	dBm/3,84 MHz
$F_{uw}$ offset	+10 or -10	+15 or -15	MHz



Table 6.5.2b: Out of band blocking

Parameter	Band 1	Band 2	Band 3	Unit
$\frac{\Sigma DPCCH - E_c}{I_{or}}$	0	0	0	dB
$I_{or}$	<REFSENS> + 3 dB	<REFSENS> + 3 dB	<REFSENS> + 3 dB	dBm/3,84 MHz
$I_{blocking}$ (CW)	-44	-30	-15	dBm
$F_{uw}$ For operation in frequency bands as defined in clause 4.2(a)	1840 <f < 1885 1935 <f < 1995 2040 <f < 2085	1815 <f < 1840 2085 <f < 2110	1 <f < 1815 2110 <f < 12750	MHz
$F_{uw}$ For operation in frequency bands as defined in clause 4.2(b)	1790 <f < 1835 2005 <f < 2050	1765 <f < 1790 2050 <f < 2075	1 <f < 1765 2075 <f < 12750	MHz
$F_{uw}$ For operation in frequency bands as defined in clause 4.2(c)	1850 <f < 1895 1945 <f < 1990	1825 <f < 1850 1990 <f < 2015	1 <f < 1825 2015 <f < 12750	MHz

NOTE 1: For operation referenced in 4.2(a), from 1885 <f < 1900 MHz, 1920 <f < 1935 MHz, 1995 <f < 2010 MHz and 2025 <f < 2040 MHz, the appropriate in-band blocking or adjacent channel selectivity in clause 6.5.2 shall be applied.

NOTE 2: For operation referenced in 4.2(b), from 1835 <f < 1850 MHz and 1990 <f < 2005 MHz, the appropriate in-band blocking or adjacent channel selectivity in clause 6.5.2 shall be applied.

NOTE 3: For operation referenced in 4.2(c), from 1895 <f < 1910 MHz and 1930 <f < 1945 MHz, the appropriate in-band blocking or adjacent channel selectivity in clause 6.5.2 shall be applied.

### 6.5.3 Test purpose

"The test stresses the ability of the UE receiver to withstand high-level interference from unwanted signals at frequency offsets of 10 MHz or more, without undue degradation of its sensitivity."

### 6.5.4 Method of test

#### 6.5.4.1 Initial conditions

For in-band case:

Test environment: normal; see clauses G.2.1 and G.2.2.

Frequencies to be tested: mid range; see clause G.2.4.

For out-of-band case:

Test environment: normal; see clauses G.2.1 and G.2.2.

Frequencies to be tested: 1 arbitrary frequency selected between low and high range; see clause G.2.4.

- 1) Connect the SS and the interfering Signal generator to the antenna connector as shown in figure A.5.
- 2) A call is set up according to the Generic call setup procedure.

- 3) Enter the UE into loopback test mode and start the loopback test.

#### 6.5.4.2 Procedure

- 1) The wanted signal frequency channel is set into the middle of the band.
- 2) The interfering Signal Generator is stepped through the frequency range indicated in table 6.5.2.a. with a step size of 1 MHz.
- 3) The interference signal shall be equivalent to a continuously running wideband CDMA signal with one code and chip frequency 3,84 Mchip/s and rolloff 0,22.
- 4) Measure the BER of the wanted signal received from the UE at the SS for each step of the interferer.
- 5) Repeat the inband blocking for wanted frequency channels low-band and high-band.
- 6) The wanted signal frequency channel is set into the middle of the band.
- 7) The interfering Signal Generator is stepped through the frequency range indicated in table 6.4.2.b with a step size of 1 MHz.
- 8) The interference signal is a CW signal.
- 9) Measure the BER of the wanted signal received from the UE at the SS for each step of the interferer.

NOTE: Due to the large amount of time-consuming BER tests it is recommended to speed up a single BER test by reducing the 0.001-BER confidence level [10 000 bits under test or 10 errors] for screening the critical frequencies. Critical frequencies must be identified using standard BER confidence level. [30 000 bits or 30 errors].

#### 6.5.5 Test requirements

The measured BER, derived in step 4 ) and 5), shall not exceed 0,001 (without exception) under test conditions described in table 6.5.5a.

The measured BER, derived in step 9), shall not exceed 0,001 except for up to 24 different frequencies of the interfering signal under test conditions described in table 6.5.5b.

These frequencies are further processed in clause 5.6 Spurious response.

**Table 6.5.5a: Test conditions In-band blocking**

Parameter	Offset 1	Offset 2	Unit
$\frac{\Sigma DPCH\_Ec}{I_{or}}$	0	0	dB
$I_{or}$	<REFSENS> + 3 dB	<REFSENS> + 3 dB	dBm/3,84 MHz
$I_{blocking}$ (modulated)	-56	-44	dBm/3,84 MHz

**Table 6.5.5b: Test conditions Out of band blocking**

Parameter	Band 1	Band 2	Band 3	Unit
$\frac{\Sigma DPCH\_Ec}{I_{or}}$	0	0	0	dB
$I_{or}$	<REFSENS> + 3 dB	<REFSENS> + 3 dB	<REFSENS> + 3 dB	dBm/3,84 MHz
$I_{blocking}$ (CW)	-44	-30	-15	dBm

NOTE: If the above Test Requirement differs from the Minimum Requirement then the Test Tolerance applied for this test is non-zero. The Test Tolerance for this test is defined in annex F clause F.2 and the explanation of how the Minimum Requirement has been relaxed by the Test Tolerance is given in annex F clause F.4.

## 6.6 Spurious Response

### 6.6.1 Definition and applicability

Spurious response is a measure of the receiver's ability to receive a wanted signal on its assigned channel frequency without exceeding a given degradation due to the presence of an unwanted CW interfering signal at any other frequency at which a response is obtained i.e. for which the blocking limit is not met.

The requirements of this test apply to all types of UTRA for the UE.

### 6.6.2 Minimum Requirements

The BER shall not exceed 0,001 for the parameters specified in table 6.6.2.

The normative reference for this requirement is TS 25.102 [1] clause 7.7.1

**Table 6.6.2: Spurious Response**

Parameter	Value	Unit
$\frac{\Sigma DPCH\_Ec}{I_{or}}$	0	dB
$\hat{I}_o$	<REFSENS> + 3	dBm/3,84 MHz
$I_{\text{blocking}} \text{ (CW)}$	-44	dBm
$F_{uw}$	Spurious response frequencies	MHz

### 6.6.3 Test purpose

Spurious response frequencies, identified in the blocking test, are measured against a less stringent test requirement. The test stresses the ability of the receiver to withstand high level interference signals without undue degradation of its sensitivity due to the receiver's frequency conversion concept.

### 6.6.4 Method of test

#### 6.6.4.1 Initial conditions

Test environment: normal; see clauses G.2.1 and G.2.2.

Frequencies to be tested: low range, high range; see clause G.2.4.

- 1) Connect the SS and the unwanted signal to the UE antenna connector as shown in figure A.6.
- 2) A call is set up according to the Generic call setup procedure.
- 3) Enter the UE into loopback test mode and start the loopback test.

#### 6.6.4.2 Procedure

- 1) Repeat the wanted signal frequency setting from the blocking test. Set the level according to table 6.6.2.
- 2) Repeat the frequency settings of the interferer signal, at which the blocking test failed. Set the level according to table 6.6.5.

3) Measure the BER of DCH received from the UE at the SS for each of the settings 1) and 2).

## 6.6.5 Test requirements

The measured BER, derived in step 3), shall not exceed 0,001 under test conditions described in table 6.6.5.

**Table 6.6.5: Test Parameters Spurious Response**

Parameter	Value	Unit
$\frac{\Sigma DPCH\_Ec}{I_{or}}$	0	dB
$\hat{I}_o$	<REFSENS> + 3	dBm/3,84 MHz
$I_{blocking}$ (CW)	-44	dBm
$F_{uw}$	Spurious response frequencies	MHz

NOTE: If the above Test Requirement differs from the Minimum Requirement then the Test Tolerance applied for this test is non-zero. The Test Tolerance for this test is defined in annex F clause F.2 and the explanation of how the Minimum Requirement has been relaxed by the Test Tolerance is given in annex F clause F.4.

## 6.7 Intermodulation Characteristics

### 6.7.1 Definition and applicability

Third and higher order mixing of the two interfering RF signals can produce an interfering signal in the band of the desired channel. Intermodulation response rejection is a measure of the capability of the receiver to receive a wanted signal on its assigned channel frequency in the presence of two or more interfering signals which have a specific frequency relationship to the wanted signal.

The requirements of this test shall apply to all UTRA UE.

### 6.7.2 Minimum Requirements

The BER shall not exceed 0,001 for the parameters specified in table 6.7.2

The normative reference for this requirement is TS 25.102 [1] clause 7.8.1.

**Table 6.7.2: Receive intermodulation characteristics**

Parameter	Value	Unit
$\frac{\Sigma DPCH\_Ec}{I_{or}}$	0	dB
$\hat{I}_o$ Wanted Signal Level	<REFSENS> + 3 dB	dBm/3,84 MHz
$I_{ouw1}$ (CW)	-46	dBm
$I_{ouw2}$ (modulated)	-46	dBm/3,84 MHz
$F_{uw1}$ (CW)	10	MHz
$F_{uw2}$ (Modulated)	20	MHz

### 6.7.3 Test purpose

The test stresses the ability of the receiver to withstand two or more high level interference signals without undue degradation of its sensitivity due to the receiver's non-linear elements.

## 6.7.4 Method of test

### 6.7.4.1 Initial conditions

Test environment: normal; see clauses G.2.1 and G.2.2.

Frequencies to be tested: mid range; see clause G.2.4.

- 1) Connect the SS and the unwanted signals to the UE antenna connector as shown in figure A.7.
- 2) A call is set up according to the Generic call setup procedure.
- 3) Enter the UE into loopback test mode and start the loopback test.

### 6.7.4.2 Procedure

- 1) Set the interfering signals as indicated in table 6.7.2. with positive offset with respect to the wanted signal.
- 2) Measure the BER of DCH received from the UE at the SS.
- 3) Set the interfering signals as indicated in table 6.7.2. with negative offset with respect to the wanted signal and repeat 2).

## 6.7.5 Test requirements

The measured BER, derived in step 2) and 3), shall not exceed 0,001 under test conditions described in table 6.7.5.

**Table 6.7.5: Test parameters Receive intermodulation characteristics**

Parameter	Value	Unit
$\frac{\Sigma DPCH - Ec}{I_{or}}$	0	dB
$I_{or}$ / Wanted Signal Level	<REFSENS> + 3 dB	dBm/3,84 MHz
$I_{ouw1}$ (CW)	-46	dBm
$I_{ouw2}$ (modulated)	-46	dBm/3,84 MHz
$F_{uw1}$ (CW)	10	MHz
$F_{uw2}$ (Modulated)	20	MHz

NOTE: If the above Test Requirement differs from the Minimum Requirement then the Test Tolerance applied for this test is non-zero. The Test Tolerance for this test is defined in annex F clause F.2 and the explanation of how the Minimum Requirement has been relaxed by the Test Tolerance is given in annex F clause F.4.

## 6.8 Spurious Emissions

### 6.8.1 Definition and applicability

The Spurious Emissions Power is the power of emissions generated or amplified in a receiver that appear at the UE antenna connector.

The requirements of this test are applicable for all UTRA UE.

### 6.8.2 Minimum Requirements

The power of any spurious emission shall not exceed:

**Table 6.8.2: Receiver spurious emission requirements**

Band	Maximum level	Measurement Bandwidth	Note
30 MHz – 1 GHz	-57 dBm	100 kHz	
1 GHz – 1,9 GHz and 1,92 GHz – 2,01 GHz and 2,025 GHz – 2,11 GHz	-47 dBm	1 MHz	With the exception of frequencies between 12,5 MHz below the first carrier frequency and 12,5 MHz above the last carrier frequency used by the UE.
1,9 GHz – 1,92 GHz and 2,01 GHz – 2,025 GHz and 2,11 GHz – 2,170 GHz	-60 dBm	3,84 MHz	With the exception of frequencies between 12,5 MHz below the first carrier frequency and 12,5 MHz above the last carrier frequency used by the UE.
2,170 GHz – 12,75 GHz	-47 dBm	1 MHz	

The normative reference for this requirement is TS 25.102 [1] clause 7.9.

### 6.8.3 Test purpose

The test purpose is to verify the UE's ability to limit interference caused by receiver spurious emissions to the own and the other systems. The test requirements are tighter than in clause 5.5.3 ((TX) Spurious Emissions) because the time of Receive-Only-Operation is generally much longer than RX-TX-Operation.

### 6.8.4 Method of test

#### 6.8.4.1 Initial conditions

Test environment: normal; see clauses G.2.1 and G.2.2.

Frequencies to be tested: 1 arbitrary frequency selected between low and high range; see clause G.2.4.

- 1) Connect the measurement equipment to the UE antenna connector according to figure A.8.
- 2) The measurement equipment shall measure power through:
  - a 100 kHz filter with a approximately gaussian filter-characteristic (typical spectrum analyzer); or
  - a 1 MHz filter with a approximately gaussian filter-characteristic (typical spectrum analyzer); or
  - a matched filter with a bandwidth equal to the chip frequency 3,84 Mchip/s and rolloff 0,22.
- 3) Enable the UE receiver and set Cell Search Mode on a PCCPCH. Since there is no down link signal, the UE should not pass the Cell Search mode.

#### 6.8.4.2 Procedure

Measure the power of spurious emissions by covering the frequency ranges of table 6.8.2. Cover the UTRA/TDD and UTRA/FDD UE receive band in contiguous steps of 200 kHz. Cover the other frequency ranges in contiguous steps of 100 kHz. Apply the corresponding filters of table 6.8.2. The step duration shall be sufficient slow to capture intermittent spurious emissions.

### 6.8.5 Test requirements

The spurious emissions shall be according to table 6.8.5.

Table 6.8.5: Receiver spurious emission test requirements

Band	Maximum level	Measurement Bandwidth	Note
30 MHz – 1 GHz	-57 dBm	100 kHz	
1 GHz – 1,9 GHz and 1,92 GHz – 2,01 GHz and 2,025 GHz – 2,11 GHz	-47 dBm	1 MHz	With the exception of frequencies between 12,5 MHz below the first carrier frequency and 12,5 MHz above the last carrier frequency used by the UE.
1,9 GHz – 1,92 GHz and 2,01 GHz – 2,025 GHz and 2,11 GHz – 2,170 GHz	-60 dBm	3,84 MHz	With the exception of frequencies between 12,5 MHz below the first carrier frequency and 12,5 MHz above the last carrier frequency used by the UE.
2,170 GHz – 12,75 GHz	-47 dBm	1MHz	

NOTE: If the above Test Requirement differs from the Minimum Requirement then the Test Tolerance applied for this test is non-zero. The Test Tolerance for this test is defined in Annex F.2 and the explanation of how the Minimum Requirement has been relaxed by the Test Tolerance is given in Annex F.4.

## 7 Performance Requirements

### 7.1 General

The performance requirements for the UE in this clause is specified for the measurement channels specified in annex C and the test environments specified in annex D.

### 7.2 Demodulation in static propagation conditions

#### 7.2.1 Demodulation of DCH

##### 7.2.1.1 Definition and applicability

The performance requirement of DCH in static propagation conditions is determined by the maximum Block Error Ratio (BLER). The BLER is specified for each individual data rate of the DCH. DCH is mapped into the Dedicated Physical Channel (DPCH).

The UE shall be tested only according to the datarates, supported. The data-rate-corresponding requirements shall apply to the UE.

##### 7.2.1.2 Minimum requirements

For the parameters specified in table 7.2.1.2a the BLER shall not exceed the piece-wise linear BLER curve specified in table 7.2.1.2b. These requirements are applicable for TFCS size 16.

The reference for this requirement is TS 25.102 [1] clause 8.2.1.1.

Table 7.2.1.2a: DCH parameters in static propagation conditions

Parameters	Unit	Test 1	Test 2	Test 3	Test 4
$\frac{\Sigma DPCH - E_c}{I_{or}}$	dB	-6	-3	0	0
$I_{oc}$	dBm/3,84 MHz	-60			
Information Data Rate	kbps	12.2	64	144	384

**Table 7.2.1.2.b: Performance requirements in AWGN channel**

Test Number	$\frac{\hat{I}_{or}}{I_{oc}}$ [dB]	BLER
1	0,1	$10^{-2}$
2	2,3	$10^{-1}$
	2,6	$10^{-2}$
3	2,2	$10^{-1}$
	2,4	$10^{-2}$
4	1,6	$10^{-1}$
	1,8	$10^{-2}$

### 7.2.1.3 Test purpose

While the receiver tests in clause 6 aims for the RF hardware, this performance requirement aims for the receiver's signal processing.

The test purpose is to verify the ability of the receiver to receive a predefined test signal ,representing a static propagation channel for the wanted and for the co-channel signals from serving and adjacent cells, with a block error ratio (BLER) not exceeding a specified value.

### 7.2.1.4 Method of test

#### 7.2.1.4.1 Initial conditions

Test environment: normal; see clauses G.2.1 and G.2.2.

Frequencies to be tested: mid range; see clause G.2.4.

- 1) Connect the SS, AWGN Generator and additional components to the UE antenna connector as shown in figure A.9.
- 2) A call is set up according to the Generic call setup procedure. The characteristic of the call shall be according to the DL reference measurement channels (12,2 kbit/s) (64 kbit/s), (144 kbit/s), and (384 kbit/s) specified in annex C.
- 3) Enter the UE into loopback test mode and start the loopback test. (test 1) and/or activate the Ack/Nack test mode (test 1 to test 4).
- 4) The levels of the wanted signal and the co-channel signals are set according to table 7.2.1.2a and b.

#### 7.2.1.4.2 Procedure

Measure the BLER of DCH received from the UE at the SS for all 4 tests.

### 7.2.1.5 Test requirements

The measured BLER shall not exceed the values indicated in table 7.2.1.2b.



## 7.3 Demodulation of DCH in multipath fading conditions

### 7.3.1 Multipath fading Case 1

#### 7.3.1.1 Definition and applicability

The performance requirement of DCH is determined by the maximum Block Error Ratio (BLER). The BLER is specified for each individual data ratio of the DCH. DCH is mapped into the Dedicated Physical Channel (DPCH).

The UE shall be tested only according to the data ratios, supported. The data-ratio-corresponding requirements shall apply to the UE.

#### 7.3.1.2 Minimum requirements

For the parameters specified in table 7.3.1.2a the BLER shall not exceed the piece-wise linear BLER curve specified in table 7.3.1.2b. These requirements are applicable for TFCS size 16.

The reference for this requirement is TS 25.102 [1] clause 8.3.1.1.

**Table 7.3.1.2a: DCH parameters in multipath Case 1 channel**

Parameters	Unit	Test 1	Test 2	Test 3	Test 4
$\frac{\Sigma DPCH - E_c}{I_{or}}$	dB	-6	-3	0	0
$I_{oc}$	dBm/3,84 MHz	-60			
Information Data Ratio	kbps	12,2	64	144	384

**Table 7.3.1.2b: Performance requirements in multipath Case 1 channel**

Test Number	$\frac{\hat{I}_{or}}{I_{oc}}$ [dB]	BLER
1	13,5	$10^{-2}$
2	13,3	$10^{-1}$
	19,6	$10^{-2}$
3	13,3	$10^{-1}$
	19,7	$10^{-2}$
4	13,5	$10^{-1}$
	20,2	$10^{-2}$

#### 7.3.1.3 Test purpose

While the receiver tests in clause 6 aims for the RF hardware, this performance requirement aims for the receiver's signal processing.

The test purpose is to verify the ability of the receiver to receive a predefined test signal, representing a multipath propagation channel for the wanted and for the co-channel signals from serving and adjacent cells, with a block error ratio (BLER) not exceeding a specified value.

#### 7.3.1.4 Method of test

##### 7.3.1.4.1 Initial conditions

Test environment: normal; see clauses G.2.1 and G.2.2.

Frequencies to be tested: mid range; see clause G.2.4.

- 1) Connect the SS, the fading simulator, the AWGN generator and additional components to the UE antenna connector as shown in figure A.10.
- 2) A call is set up according to the Generic call setup procedure. The characteristic of the call shall be according to the DL reference measurement channels (12,2 kbit/s), (64 kbit/s), (144 kbit/s), and (384 kbit/s) specified in annex C.
- 3) Enter the UE into loopback test mode and start the loopback test. (test 1) and/or activate the Ack/Nack test mode (test 1 to test 4).
- 4) The levels of the wanted signal and the co-channel signals are set according to table 7.3.1.2a and b.

#### 7.3.1.4.2 Procedure

Measure the BLER of DCH received from the UE at the SS for all 4 tests.

#### 7.3.1.5 Test requirements

The measured BLER shall not exceed the values indicated in table 7.3.1.2b.

### 7.3.2 Multipath fading Case 2

#### 7.3.2.1 Definition and applicability

The performance requirement of DCH is determined by the maximum Block Error Ratio (BLER). The BLER is specified for each individual data rate of the DCH. DCH is mapped into the Dedicated Physical Channel (DPCH).

The UE shall be tested only according to the datarates, supported. The data-rate-corresponding requirements shall apply to the UE.

#### 7.3.2.2 Minimum requirement

For the parameters specified in table 7.3.2.2a the BLER should not exceed the piece-wise linear BLER curve specified in table 7.3.2.2b. . These requirements are applicable for TFCS size 16.

The reference for this requirement is TS 25.102 [1] clause 8.3.2.1.

**Table 7.3.2.2a: DCH parameters in multipath Case 2 channel**

Parameters	Unit	Test 1	Test 2	Test 3	Test 4
$\frac{\Sigma DPCH - E_c}{I_{or}}$	DB	-3	0	0	0
$I_{oc}$	dBm/3,84 MHz	-60			
Information Data Rate	kbps	12,2	64	144	384

**Table 7.3.2.2b: Performance requirements in multipath Case 2 channel**

Test Number	$\frac{\hat{I}_{or}}{I_{oc}}$ [dB]	BLER
1	5,5	$10^{-2}$
2	5,8	$10^{-1}$
	9,7	$10^{-2}$
3	9,5	$10^{-1}$
	13,2	$10^{-2}$
4	8,5	$10^{-1}$
	12,6	$10^{-2}$

### 7.3.2.3 Test purpose

While the receiver tests in clause 6 aims for the RF hardware, this performance requirement aims for the receiver's signal processing.

The test purpose is to verify the ability of the receiver to receive a predefined test signal, representing a multipath propagation channel for the wanted and for the co-channel signals from serving and adjacent cells, with a block error ratio (BLER) not exceeding a specified value.

### 7.3.2.4 Method of test

#### 7.3.2.4.1 Initial conditions

Test environment: normal; see clauses G.2.1 and G.2.2.

Frequencies to be tested: mid range; see clause G.2.4.

- 1) Connect the SS, the fading simulator, the AWGN generator and additional components to the UE antenna connector as shown in figure A.10.
- 2) A call is set up according to the Generic call setup procedure. The characteristic of the call shall be according to the DL reference measurement channels (12,2 kbit/s) (64 kbit/s), (144 kbit/s), and (384 kbit/s) specified in annex C.
- 3) Enter the UE into loopback test mode and start the loopback test. (test 1) and/or activate the Ack/Nack test mode (test 1 to test 4).
- 4) The levels of the wanted signal and the co-channel signals are set according to table 7.3.2.2a and b.

#### 7.3.2.4.2 Procedure

Measure the BLER of DCH received from the UE at the SS for all 4 tests.

### 7.3.2.5 Test requirements

The measured BLER shall not exceed the values indicated in table 7.3.2.2b.

## 7.3.3 Multipath fading Case 3

### 7.3.3.1 Definition and applicability

The performance requirement of DCH is determined by the maximum Block Error Ratio (BLER). The BLER is specified for each individual data rate of the DCH. DCH is mapped into the Dedicated Physical Channel (DPCH).

The UE shall be tested only according to the datarates, supported. The data-rate-corresponding requirements shall apply to the UE.

### 7.3.3.2 Minimum requirements

For the parameters specified in table 7.3.3.2a the BLER should not exceed the piece-wise linear BLER curve specified in table 7.3.3.2b. These requirements are applicable for TFCS size 16.

The reference for this requirement is TS 25.102 [1] clause 8.3.3.1.

Table 7.3.3.2a: DCH parameters in multipath Case 3 channel

Parameters	Unit	Test 1	Test 2	Test 3	Test 4
$\frac{\Sigma DPCH - E_c}{I_{or}}$	dB	-3	0	0	0
$I_{oc}$	dBm/3,84 MHz	-60			
Information Data Rate	kbps	12,2	64	144	384

Table 7.3.3.2b: Performance requirements in multipath Case 3 channel

Test Number	$\frac{\hat{I}_{or}}{I_{oc}}$ [dB]	BLER
12.2 kbps	4,7	$10^{-2}$
64 kbps	5,2	$10^{-1}$
	8,4	$10^{-2}$
	12,1	$10^{-3}$
144 kbps	11,7	$10^{-1}$
	15,2	$10^{-2}$
	17,8	$10^{-3}$
384 kbps	8,2	$10^{-1}$
	11,3	$10^{-2}$
	13,0	$10^{-3}$

### 7.3.3.3 Test purpose

While the receiver tests in clause 6 aims for the RF hardware, this performance requirement aims for the receiver's signal processing.

The test purpose is to verify the ability of the receiver to receive a predefined test signal ,representing a multipath propagation channel for the wanted and for the co-channel signals from serving and adjacent cells, with a block error ratio (BLER) not exceeding a specified value.

### 7.3.3.4 Method of test

#### 7.3.3.4.1 Initial conditions

Test environment: normal; see clauses G.2.1 and G.2.2.

Frequencies to be tested: mid range; see clause G.2.4.

- 1) Connect the SS, the fading simulator, the AWGN generator and additional components to the UE antenna connector as shown in figure A.10.
- 2) A call is set up according to the Generic call setup procedure. The characteristic of the call shall be according to the DL reference measurement channels (12.2 kbit/s)(64 kbit/s), (144 kbit/s), and (384 kbit/s) specified in annex C.
- 3) Enter the UE into loopback test mode and start the loopback test. (test 1) and/or activate the Ack/Nack test mode (test 1 to test 4).
- 4) The levels of the wanted signal and the co-channel signals are set according to table 7.3.3.2a and b.

#### 7.3.3.4.2 Procedure

Measure the BLER of DCH received from the UE at the SS for all 4 tests.

### 7.3.3.5 Test requirements

The measured BLER shall not exceed the values indicated in table 7.3.3.2.b.

## 7.4 Base station transmit diversity mode

### 7.4.1 Demodulation of BCH in Block STTD mode

This is not tested.

## 7.5 Power control in downlink

Power control in the downlink is the ability of the UE receiver to converge to the required link quality set by the network while using minimum downlink power.

### 7.5.1 Minimum requirements

For the parameters specified in table 7.5.1.a the average downlink  $\hat{I}_{or}/I_{oc}$  power shall not exceed the values specified in table 7.5.1.b. Downlink power control is ON during the test.

**Table 7.5.1.a: Test parameters for downlink power control**

Parameter	Unit	Test 1	Test 2
$\frac{DPCH - E_c}{I_{or}}$	dB	0	[ ]
$I_{oc}$	dBm/3,84 MHz	-60	
Information Data Rate	kbps	12,2	
Target quality value on DTCH	BLER	0,01	
Propagation condition		Case 4	

**Table 7.5.1.b: Requirements for downlink power control**

Parameter	Unit	Test 1	Test 2
$\hat{I}_{or}/I_{oc}$	dB	[ ]	[ ]
Measured quality on DTCH	BLER	0,01±30%	0,01±30%

---

## 8 Requirements for Support of RRM

### 8.1 General

Void.

### 8.2 Idle Mode Tasks

#### 8.2.1 Introduction

Void.

## 8.2.2 RF Cell Selection Scenario

### 8.2.2.1 Requirements for Cell Selection single carrier single cell case

Void.

### 8.2.2.2 Requirements for Cell Selection multicarrier carrier multi cell case

Void.

## 8.2.3 RF Cell Re-Selection Scenario

### 8.2.3.1 Requirements for Cell Re-Selection single carrier multi cell case

Void.

## 8.2.4 PLMN Selection and Re-Selection Scenario

Void.

## 8.2.5 Location Registration Scenario

Void.

## 8.3 RRC Connection mobility

### 8.3.1 Handover

#### 8.3.1.1 Introduction

Void.

#### 8.3.1.2 Handover 3G to 3G

##### 8.3.1.2.1 TDD/TDD Handover

Void.

##### 8.3.1.2.2 TDD/FDD Handover

Void.

#### 8.3.1.3 Handover 3G to 2G

##### 8.3.1.3.1 Handover to GSM

Void.

### 8.3.2 Radio Link Management

#### 8.3.2.1 Link adaptation

Void.

### 8.3.3 Cell Update

Void.

### 8.3.4 URA Update

Void.

## 8.4 RRC Connection Control

### 8.4.1 Radio Access Bearer Control

Void.

## 8.5 Dynamic Channel Allocation

Void.

## 8.6 Timing characteristics

### 8.6.1 Timing Advance (TA) Requirements

Void.

## 8.7 Measurements Performance Requirements

### 8.7.1 Measurements Performance for UE

Void.

# Annex A (informative): Connection Diagrams

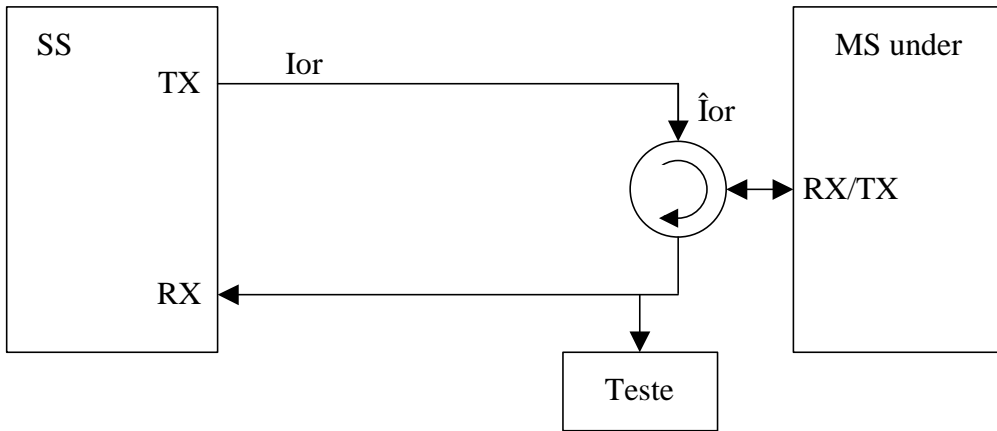

Figure A.1: Connection for Basic TX Test

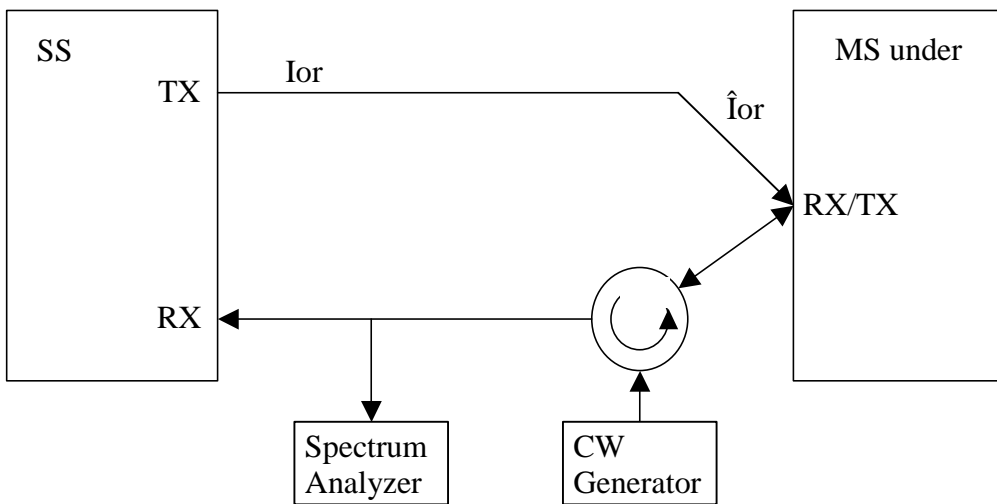

Figure A.2: Connection for TX Intermodulation Test

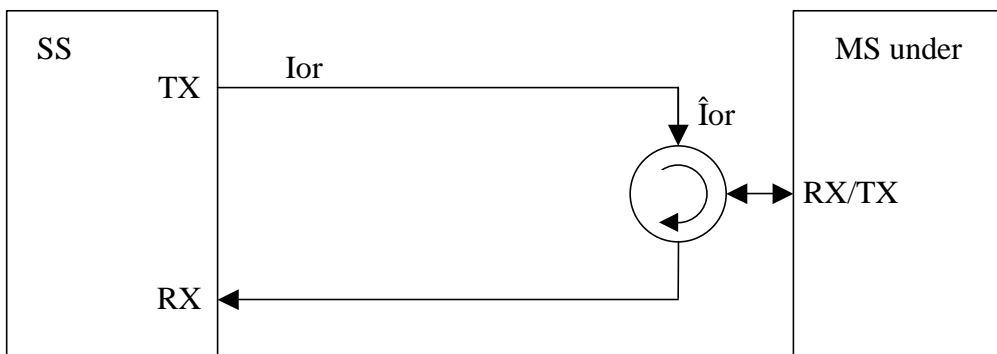

Figure A.3: Connection for Basic RX Test



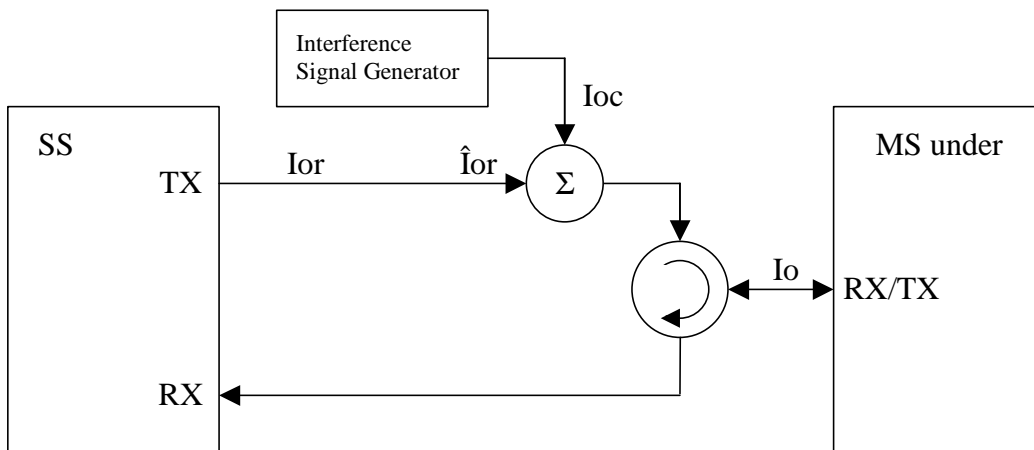

Figure A.4: Connection for RX Test with Interference

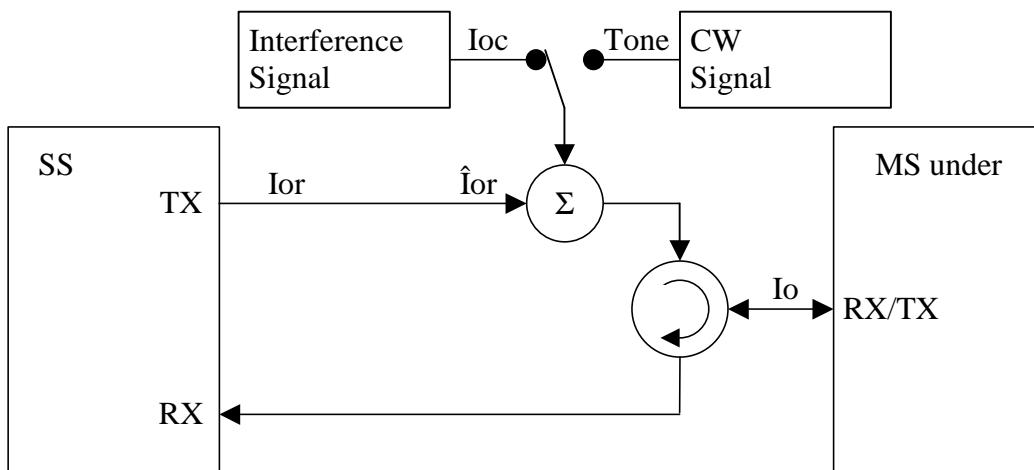

Figure A.5: Connection for RX Test with Interference or additional CW

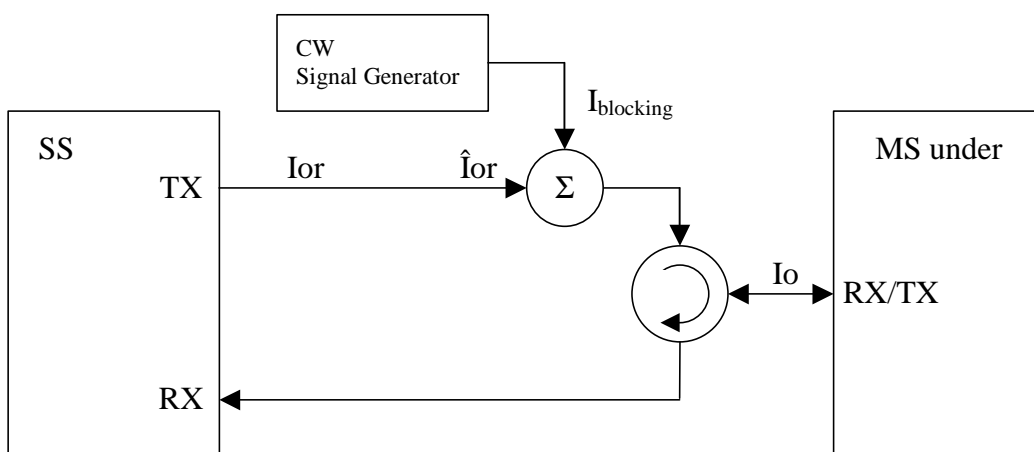

Figure A.6: Connection for RX Test with additional CW

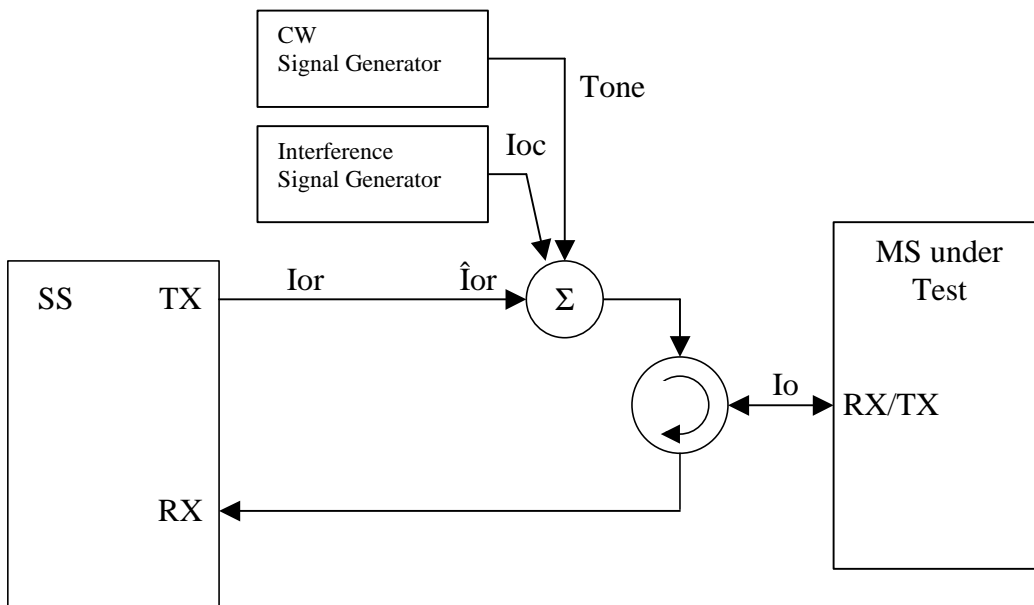

Figure A.7: Connection for RX Test with both Interference and additional CW



Figure A.8: Connection for Spurious Emission Test

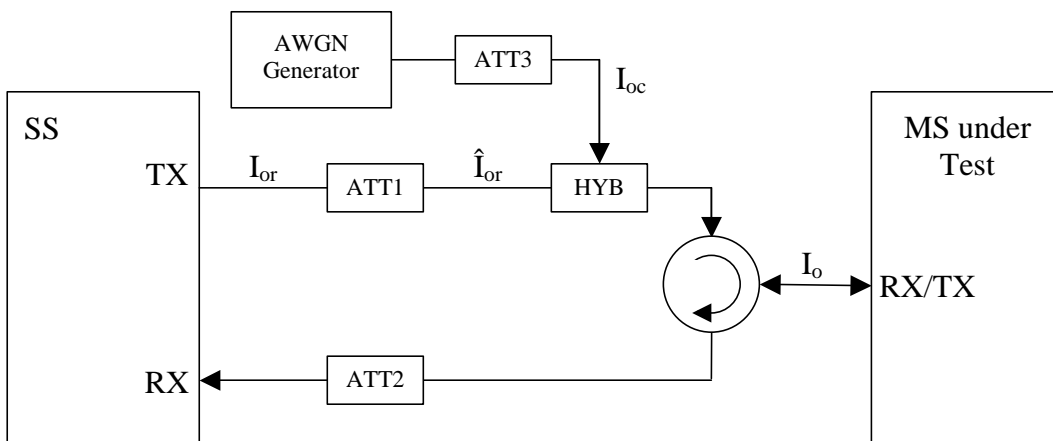

Figure A.9: Connection for Static Channel Test

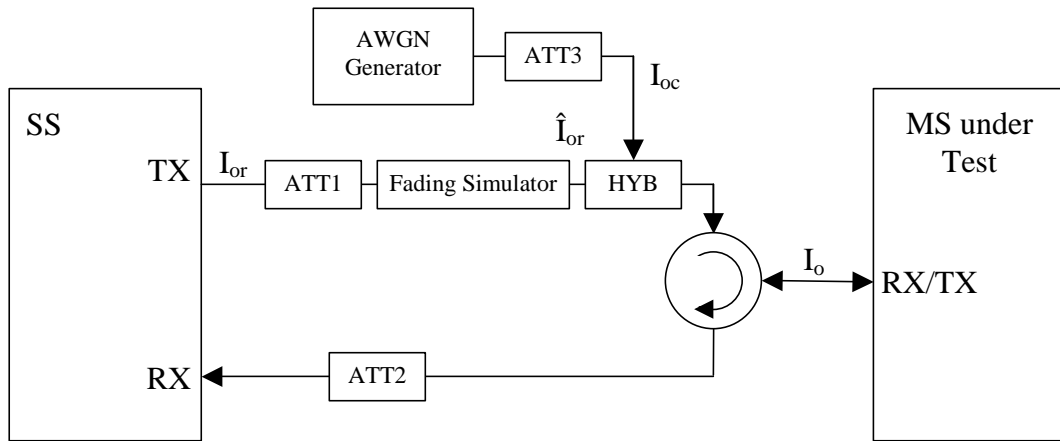

Figure A.10: Connection for Multiple Fading Channel Test

---

## Annex B (normative): Global In-Channel TX-Test

### B.1 General

The global in-channel Tx test enables the measurement of all relevant parameters that describe the in-channel quality of the output signal of the Tx under test in a single measurement process.

The parameters describing the in-channel quality of a transmitter, however, are not necessarily independent. The algorithm chosen for description inside this annex places particular emphasis on the exclusion of all interdependencies among the parameters. Any other algorithm (e.g. having better computational efficiency) may be applied, as long as the results are the same within the accuracy limits.

All notes referred in the various clauses of B.2 are put together in B.3.

---

### B.2 Definition of the process

#### B.2.1 Basic principle

The process is based on the comparison of the actual **output signal of the TX under test**, received by an ideal receiver, with a **reference signal**, that is generated by the measuring equipment and represents an ideal error free received signal. All signals are represented as equivalent (generally complex) baseband signals.

#### B.2.2 Output signal of the TX under test

The output signal of the TX under test is acquired by the measuring equipment, filtered by a matched filter (RRC 0.22, correct in shape and in position on the frequency axis) and stored at one sample per chip at the Inter-Symbol-Interference free instants.

The following form represents the physical signal in the entire measurement interval:

one vector **Z**, containing  $N = n_s \times sf + m_a$  complex samples;

with

$n_s$ : number of symbols in the measurement interval;

$sf$ : number of chips per symbol. ( $sf$ : spreading factor) (see Note: Symbol length)

$m_a$ : number of midamble chips (only in TDD)

#### B.2.3 Reference signal

The reference signal is constructed by the measuring equipment according to the relevant TX specifications.

It is filtered by the same matched filter, mentioned in B.2.2., and stored at the Inter-Symbol-Interference free instants. The following form represents the reference signal in the entire measurement interval:

one vector **R**, containing  $N = n_s \times sf + m_a$  complex samples;

$n_s$ ,  $sf$ ,  $m_a$ : see B.2.2

## B.2.4 void

## B.2.5 Classification of measurement results

The measurement results achieved by the global in-channel TX test can be classified into two types:

Results of type “deviation”, where the error-free parameter has a non-zero magnitude. (These are the parameters that quantify the integral physical characteristic of the signal). These parameters are:

- RF Frequency
- Power (in case of single code)
- Code Domain Power (in case of multi code)
- Timing (only for UE)

(Additional parameters: see Note: Deviation)

Results of type “residual”, where the error-free parameter has value zero. (These are the parameters that quantify the error values of the measured signal, whose ideal magnitude is zero). These parameters are:

- Error Vector Magnitude (EVM);
- Peak Code Domain Error (PCDE).
- (Additional parameters: see Note residual).

## B.2.6 Process definition to achieve results of type “deviation”

The reference signal (**R**; see clause B.2.3) is varied with respect to the parameters mentioned in clause B.2.5 under “results of type deviation” in order to achieve best fit with the recorded signal under test (**Z**; see clause B.2.2). Best fit is achieved when the RMS difference value between the signal under test and the varied reference signal is an absolute minimum. The varied reference signal, after the best fit process, will be called **R'**.

The varying parameters, leading to **R'** represent directly the wanted results of type “deviation”. These measurement parameters are expressed as deviation from the reference value with units same as the reference value.

In case of multi code, the type-“deviation”-parameters (frequency, timing and (RF-phase)) are varied commonly for all codes such that the process returns one frequency-deviation, one timing deviation, (one RF-phase –deviation).

(These parameters are not varied on the individual codes signals such that the process returns k frequency errors... . (k: number of codes)).

The only type-“deviation”-parameters varied individually are code powers such that the process returns k code power deviations (k: number of codes).

## B.2.7 Process definition to achieve results of type "residual"

The difference between the varied reference signal ( $\mathbf{R}'$ ; see clause B.2.6.) and the TX signal under test ( $\mathbf{Z}$ ; see clause B.2.2) is the error vector  $\mathbf{E}$  versus time:

$$\mathbf{E} = \mathbf{Z} - \mathbf{R}'.$$

Depending on the parameter to be evaluated, it is appropriate to represent  $\mathbf{E}$  in one of the following two different forms:

Form EVM (representing the physical error signal in the entire measurement interval)

One vector  $\mathbf{E}$ , containing  $N = n_s \times s_f + m_a$  complex samples;

$n_s$ ,  $s_f$ ,  $m_a$ : see B.2.2

Form PCDE (derived from Form EVM by separating the samples into symbol intervals)

$n_s$  time-sequential vectors  $\mathbf{e}$  with  $s_f$  complex samples comprising one symbol interval.

$\mathbf{E}$  gives results of type "residual" applying the two algorithms defined in clauses B 2.7.1 and B 2.7.2.

### B.2.7.1 Error Vector Magnitude (EVM)

The Error Vector Magnitude EVM is calculated according to the following steps:

- 1) Take the error vector  $\mathbf{E}$  defined in clause B.2.7 (Form EVM) and calculate the RMS value of  $\mathbf{E}$ ; the result will be called  $\text{RMS}(\mathbf{E})$ .
- 2) Take the varied reference vector  $\mathbf{R}'$  defined in clause B.2.6 and calculate the RMS value of  $\mathbf{R}'$ ; the result will be called  $\text{RMS}(\mathbf{R}')$ .
- 3) Calculate EVM according to:

$$\text{EVM} = \frac{\text{RMS}(\mathbf{E})}{\text{RMS}(\mathbf{R}')} \times 100\% \quad (\text{here, EVM is relative and expressed in \%})$$

(see note TDD)

### B.2.7.2 Peak Code Domain Error (PCDE)

The Peak Code Domain Error is calculated according to the following steps:

- 1) Take the error vectors  $\mathbf{e}$  defined in clause B.2.7 (Form PCDE)
- 2) Take the orthogonal vectors of the channelisation - code set  $\mathbf{C}$  (all codes belonging to one spreading factor) as defined in TS 25.213 and TS 25.223 (range +1, -1). (see Note: Symbol length)
- 3) To achieve meaningful results it is necessary to descramble  $\mathbf{e}$ , leading to  $\mathbf{e}'$  (see Note1: Scrambling code)
- 4) Calculate the inner product of  $\mathbf{e}'$  with  $\mathbf{C}$ . Do this for all symbols of the measurement interval and for all codes in the code space.  
This gives an array of format  $k \times n_s$ , each value representing an error-vector representing a specific symbol and a specific code, which can be exploited in a variety of ways.

$k$ : number of codes

$n_s$ : number of symbols in the measurement interval

- 5) Calculate  $k$  RMS values, each RMS value unifying  $n_s$  symbols within one code.  
(These values can be called "Absolute CodeEVMs" [Volt].)
- 6) Find the peak value among the  $k$  "Absolute CodeEVMs".  
(This value can be called "Absolute PeakCodeEVM" [Volt].)

7) Calculate PCDE according to:

$$10 \cdot \lg \frac{(\text{“Absolute PeakCodeEVM”})^2}{(\text{RMS}(\mathbf{R}'))^2} \quad \text{dB} \quad (\text{a relative value in dB}).$$

(see Note: Denominator)

(see Note2: Scrambling code)

(see Note IQ)

(see Note TDD)

(see Note Synch channel)

## B.3 Notes

### Note: Symbol length)

A general code multiplexed signal is multicode and multirate. In order to avoid unnecessary complexity, the measurement applications use a unique symbol-length, corresponding to a spreading factor, regardless of the really intended spreading factor. Nevertheless the complexity with a multicode / multirate signal can be mastered by introducing appropriate definitions.

### Note: Deviation)

It is conceivable to regard more parameters as type „deviation“ e.g. Chip frequency and RF-phase.

As chip-frequency and RF-frequency are linked together by a statement in the core specifications [1] it is sufficient to process RF frequency only.

A parameter RF-phase must be varied within the best fit process (B 2.6.). Although necessary, this parameter-variation doesn't describe any error, as the modulation schemes used in the system don't depend on an absolute RF-phase.

### Note: residual)

It is conceivable to regard more parameters as type „residual“ e.g. IQ origin offset. As it is not the intention of the test to separate for different error sources, but to quantify the quality of the signal, all such parameters are not extracted by the best fit process, instead remain part of EVM and PCDE.

### Note: Denominator)

If the denominator stems from mutual time shifted signals of different code powers, (e.g. BS, FDD ) the measurement result PCDE should be expressed absolutely instead.

### Note1: Scrambling Code)

In general a TX signal under test can use more than one scrambling code. Note that PCDE is processed regarding the unused channelisation - codes as well. In order to know which scrambling code shall be applied on unused channelisation - codes, it is necessary to restrict the test conditions: TX signal under test shall use exactly one scrambling code.

### Note2 Scrambling Code)

To interpret the measurement results in practice it should be kept in mind that erroneous code power on unused codes is generally de-scrambled differently under test conditions and under real life conditions, whereas erroneous code power on used codes is generally de-scrambled equally under test conditions and under real life conditions. It might be indicated if a used or unused code hits PCDE.

**Note IQ)**

As in FDD/uplink each code can be used twice, on the I and on the Q channel, the measurement result may indicate on which channel (I or Q) PCDE occurs.

**Note TDD)**

EVM covers the midamble part as well as the data part; however PCDE disregards the midamble part.

**Note: Synch Channel)**

A BS signal contains a physical synch channel, which is non orthogonal, related to the other DPCHs. In this context note: The code channel bearing the result of PCDE is exactly one of the DPCHs (never the synch channel). The origin of PCDE (erroneous code power) can be any DPCH and/or the synch channel.



---

## Annex C (normative): Measurement channels

### C.1 General

Void.

## C.2 UL Reference measurement channels

### C.2.1 UL reference measurement channel (12.2 kbps)

Parameter	
Information data rate	12.2 kbps
RU's allocated	2 RU
Midamble	512 chips
Interleaving	20 ms
Power control	2 Bit/user
TFCI	16 Bit/user
Inband signalling DCCH	2 kbps
Puncturing level at Code rate 1/3 : DCH / DCCH	5% / 0%

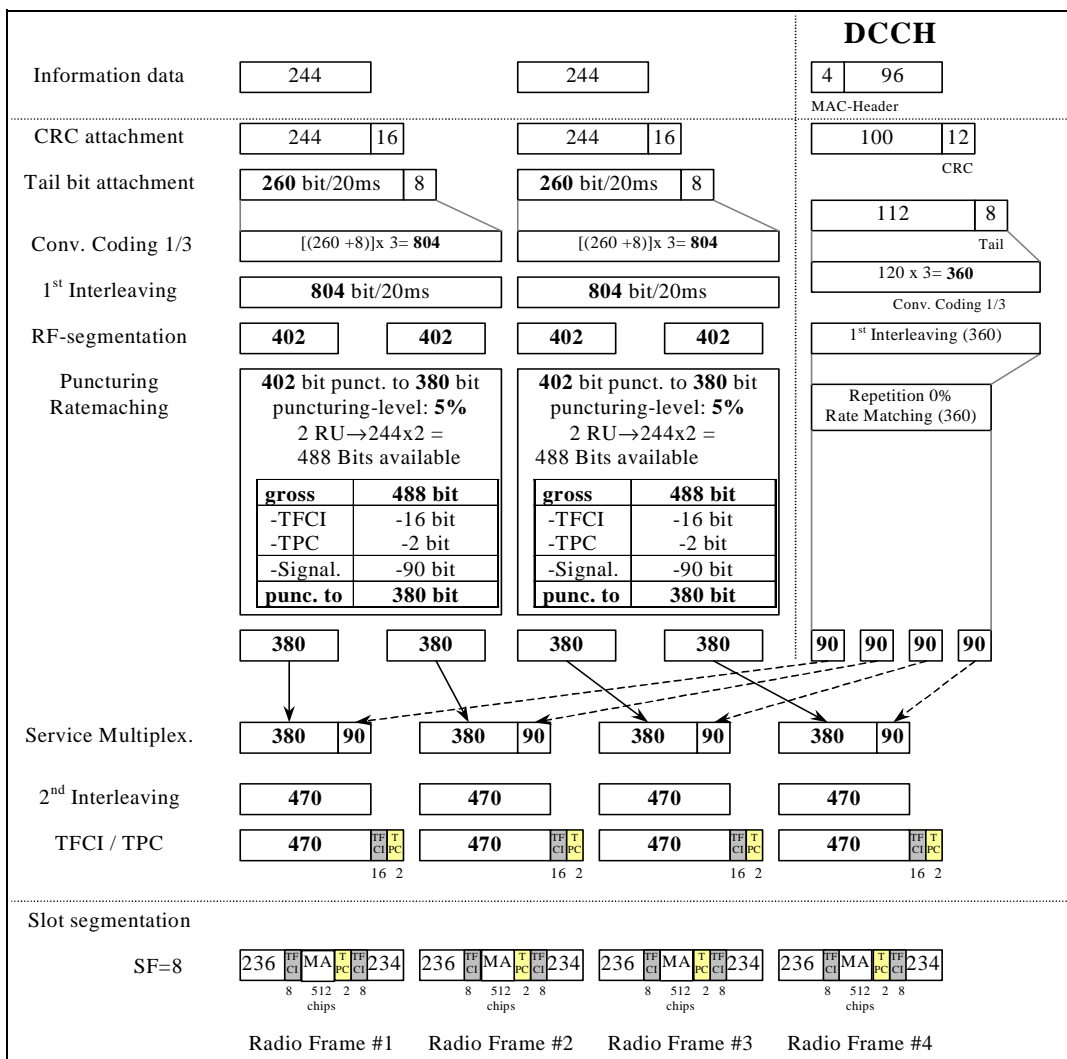

### C.2.2 UL multi code reference measurement channel (12.2 kbps)

Parameter	
Information data rate	12.2 kbps
RU's allocated	2 RU
Midamble	512 chips
Interleaving	20 ms
Power control	2 Bit/user
TFCI	16 Bit/user
Inband signalling DCCH	2 kbps
Puncturing level at Code rate 1/3 : DCH / DCCH	5% / 0 %

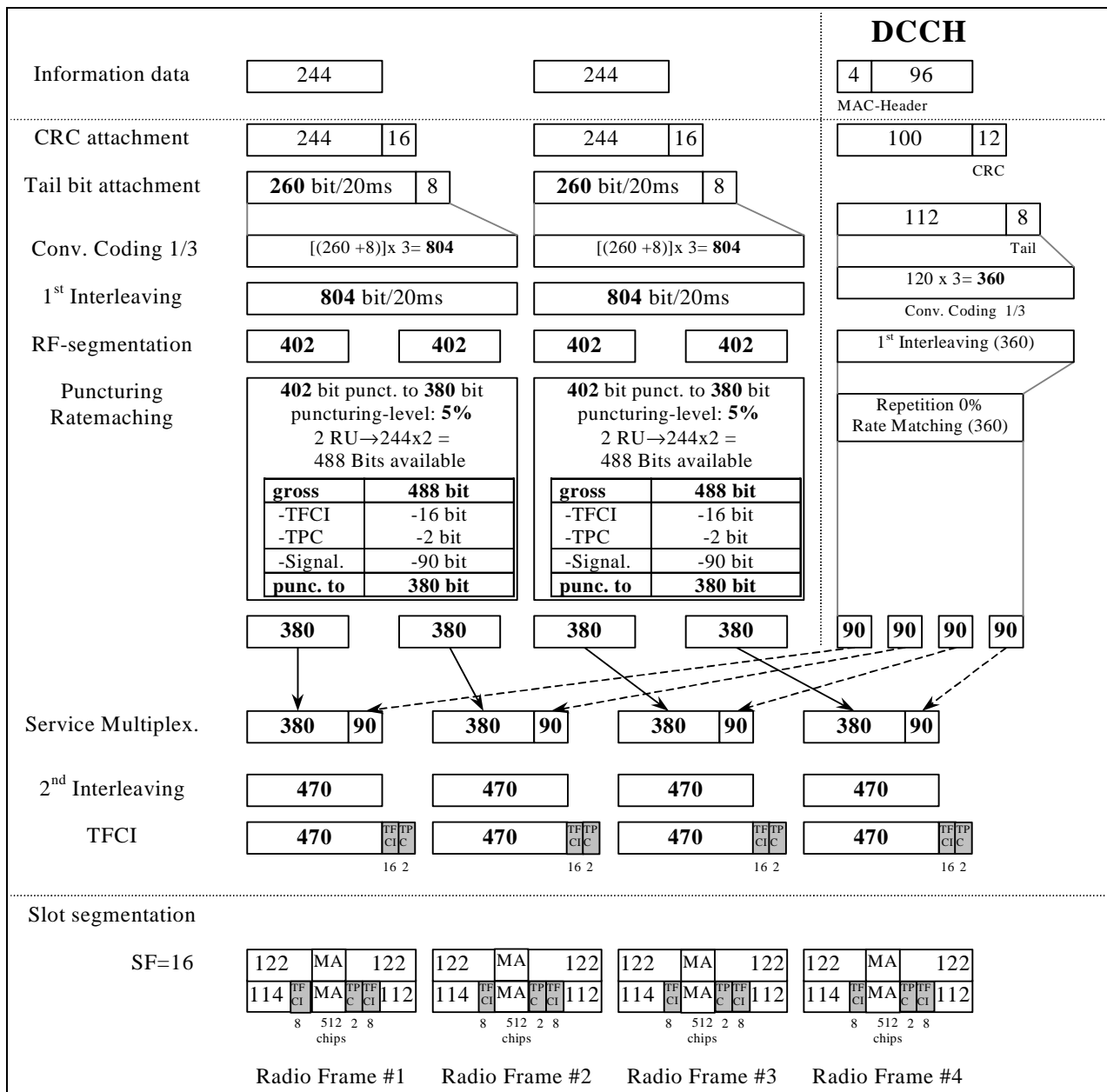

### C.2.3 UL reference measurement channel (64 kbps)

Parameter	
Information data rate	64 kbps
RU's allocated	1 SF4 + 1 SF16 = 5RU
Midamble	512 chips
Interleaving	20 ms
Power control	2 Bit/user
TFCI	16 Bit/user
Inband signalling DCCH	2 kbps
Puncturing level at Code rate : 1/3 DCH / 1/2 DCCH	41.2% / 10%

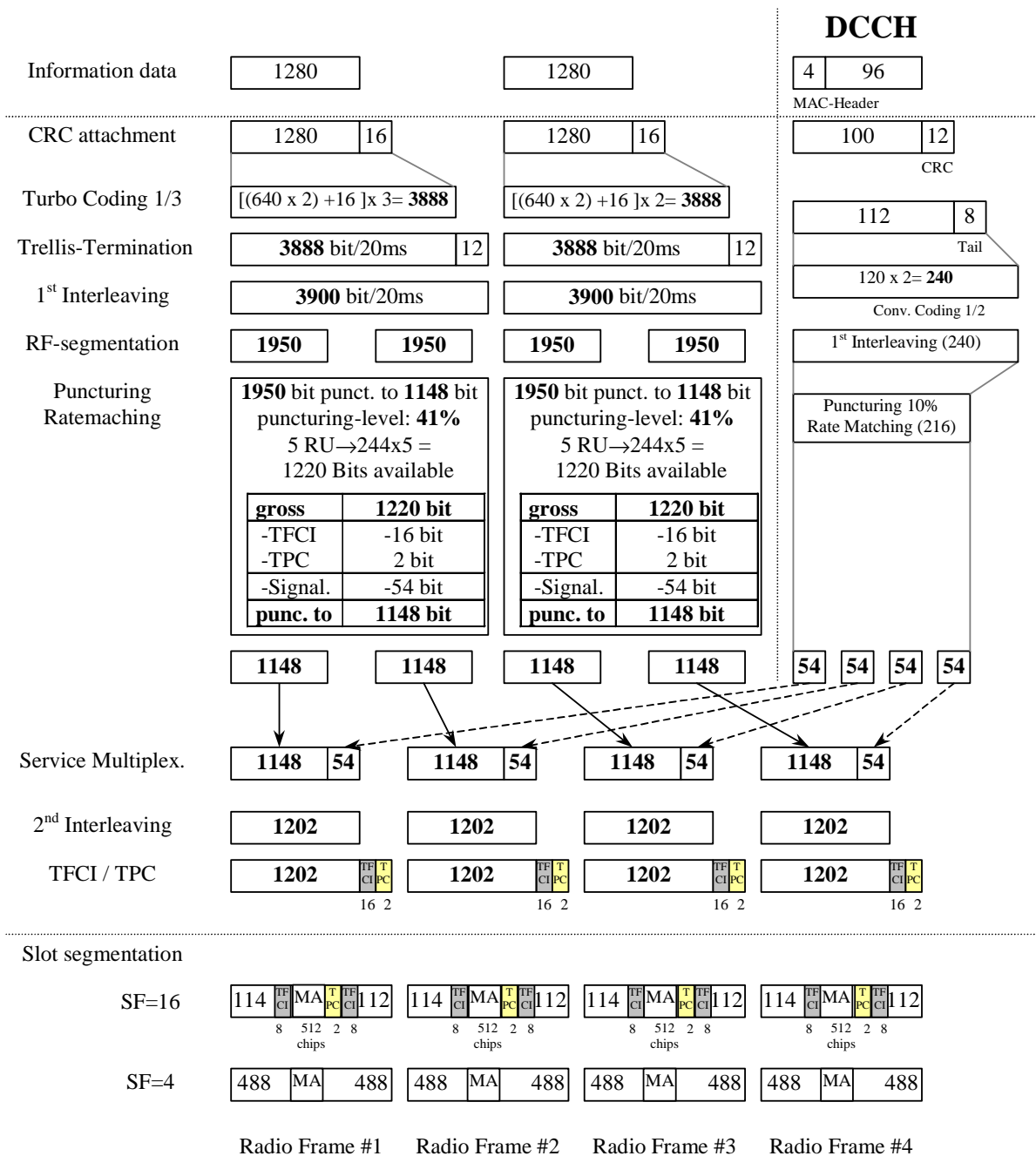

### C.2.4 UL reference measurement channel (144 kbps)

Parameter	
Information data rate	144 kbps
RU's allocated	1 SF2 + 1 SF16 = 9RU
Midamble	256 chips
Interleaving	20 ms
Power control	2 Bit/user
TFCI	16 Bit/user
Inband signalling DCCH	2 kbps
Puncturing level at Code rate : 1/3 DCH / 1/2 DCCH	44.4% / 16.6%

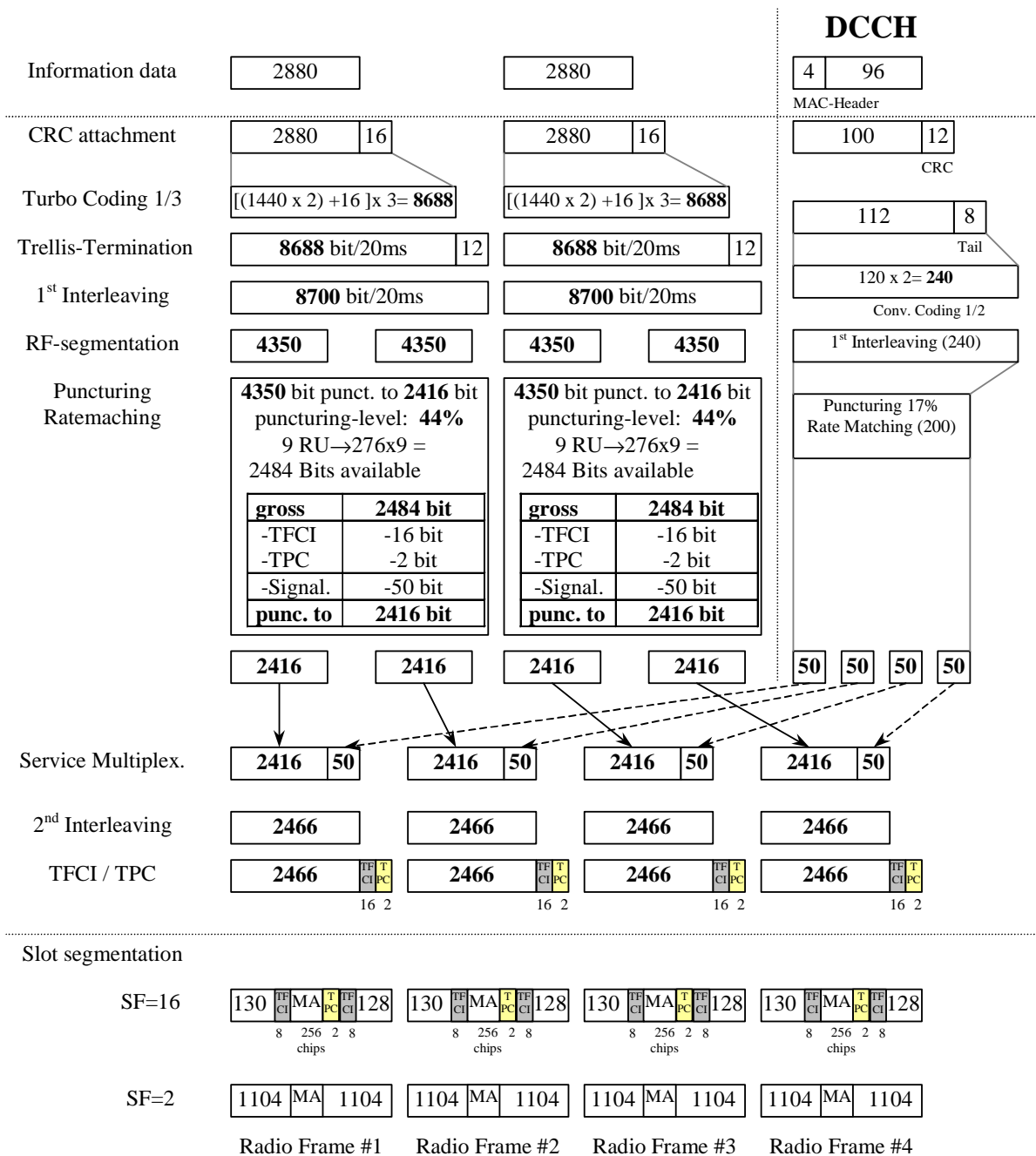

### C.2.5 UL reference measurement channel (384 kbps)

Parameter	
Information data rate	384 kbps
RU's allocated	8*3TS = 24RU
Midamble	256 chips
Interleaving	20 ms
Power control	2 Bit/user
TFCI	16 Bit/user
Inband signalling DCCH	2 kbps
Puncturing level at Code rate : 1/3 DCH / 1/2 DCCH	43.4% / 15.3%

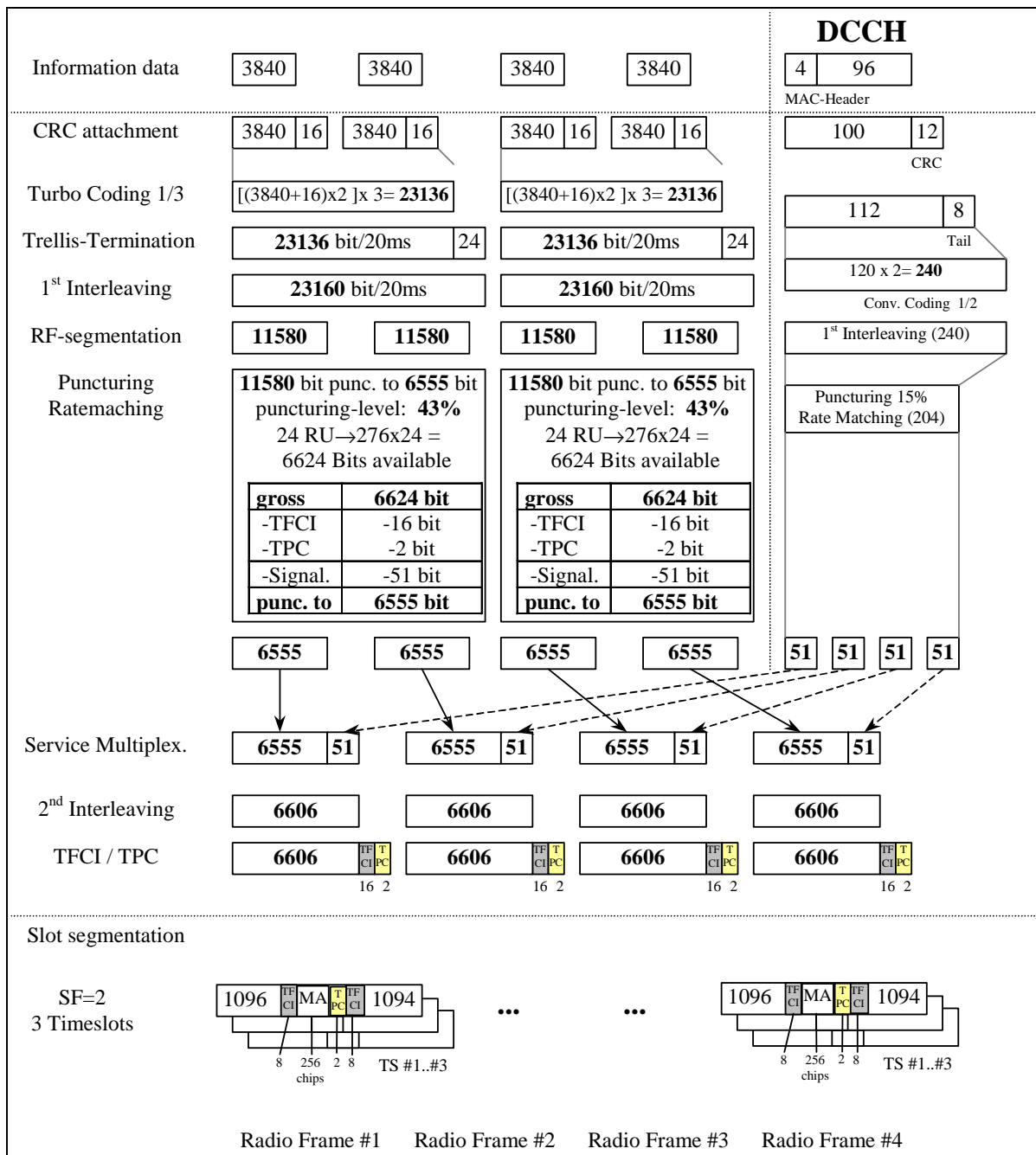

### C.3 DL Reference measurement channels

#### C.3.1 DL reference measurement channel (12.2 kbps)

Parameter	
Information data rate	12.2 kbps
RU's allocated	2 RU
Midamble	512 chips
Interleaving	20 ms
Power control	0 Bit/user
TFCI	16 Bit/user
Inband signalling DCCH	2 kbps
Puncturing level at Code rate 1/3 : DCH / DCCH	5% / 0 %

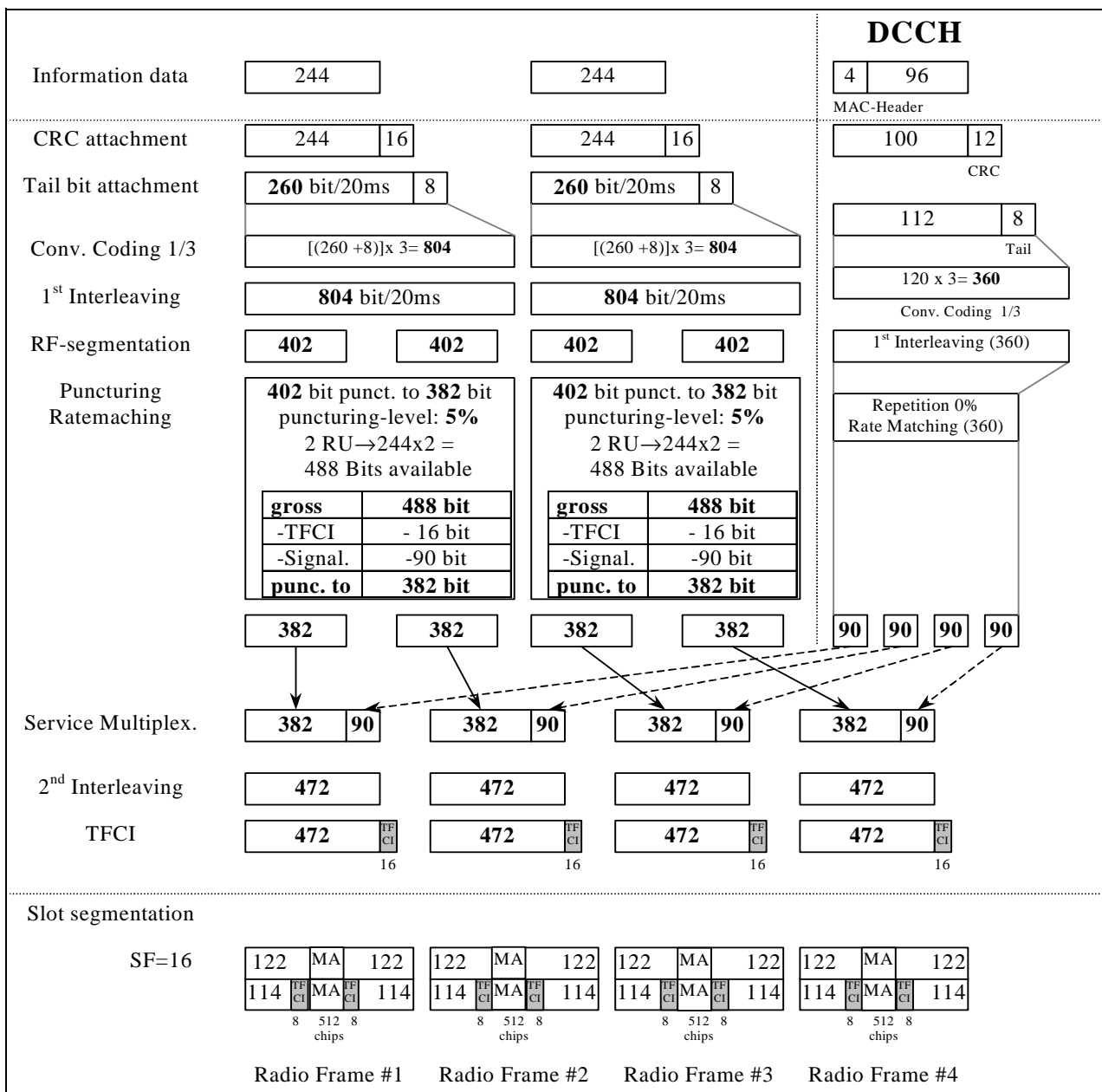

### C.3.2 DL reference measurement channel (64 kbps)

Parameter	
Information data rate	64 kbps
RU's allocated	5 codes SF16 = 5RU
Midamble	512 chips
Interleaving	20 ms
Power control	0 Bit/user
TFCI	16 Bit/user
Inband signalling DCCH	2 kbps
Puncturing level at Code rate : 1/3 DCH / 1/2 DCCH	41.1% / 10%

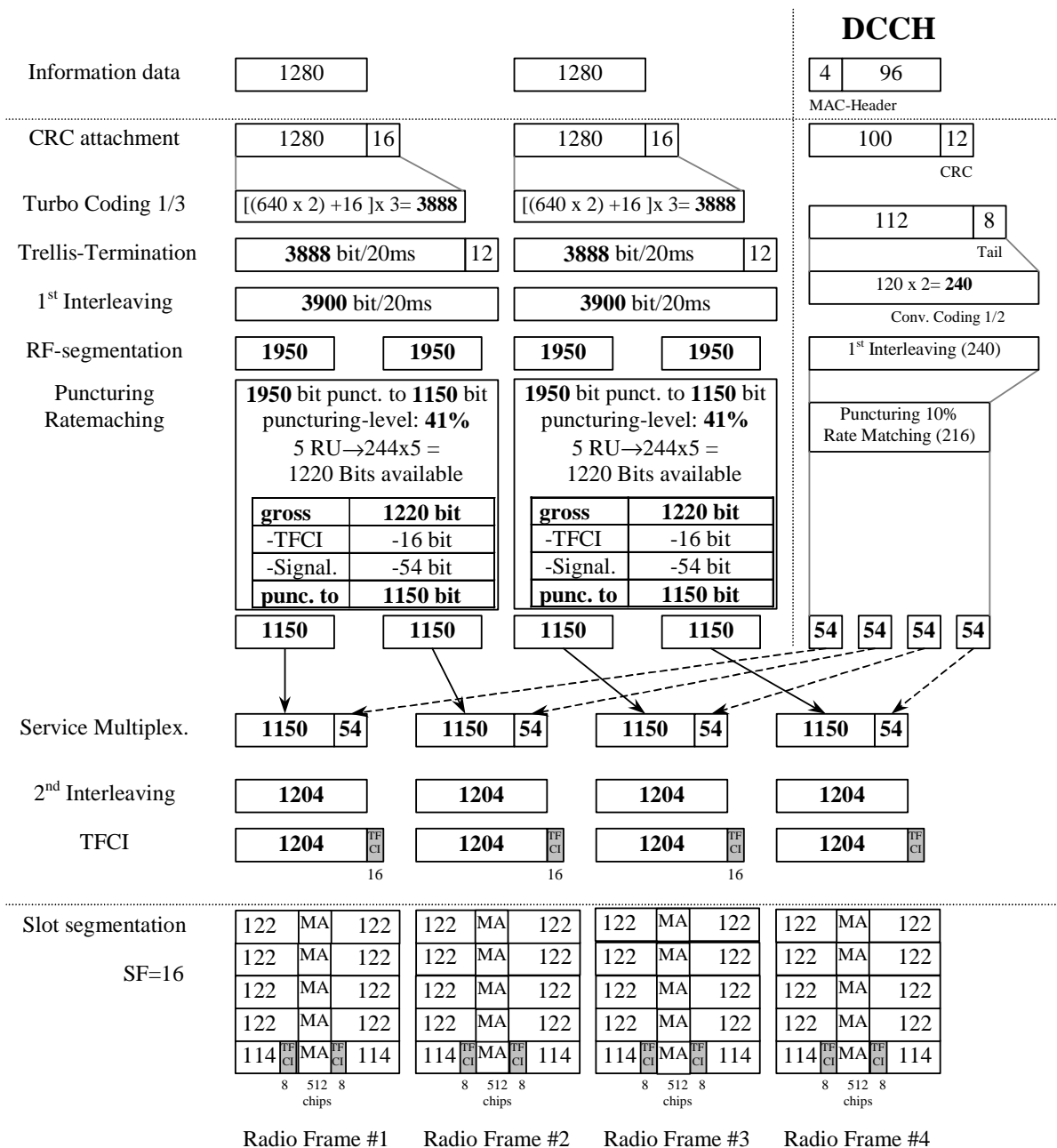



### C.3.3 DL reference measurement channel (144 kbps)

Parameter	
Information data rate	144 kbps
RU's allocated	9 codes SF16 = 9RU
Midamble	256 chips
Interleaving	20 ms
Power control	0 Bit/user
TFCI	16 Bit/user
Inband signalling DCCH	2 kbps
Puncturing level at Code rate: 1/3 DCH / 1/2 DCCH	44.5% / 16.6%

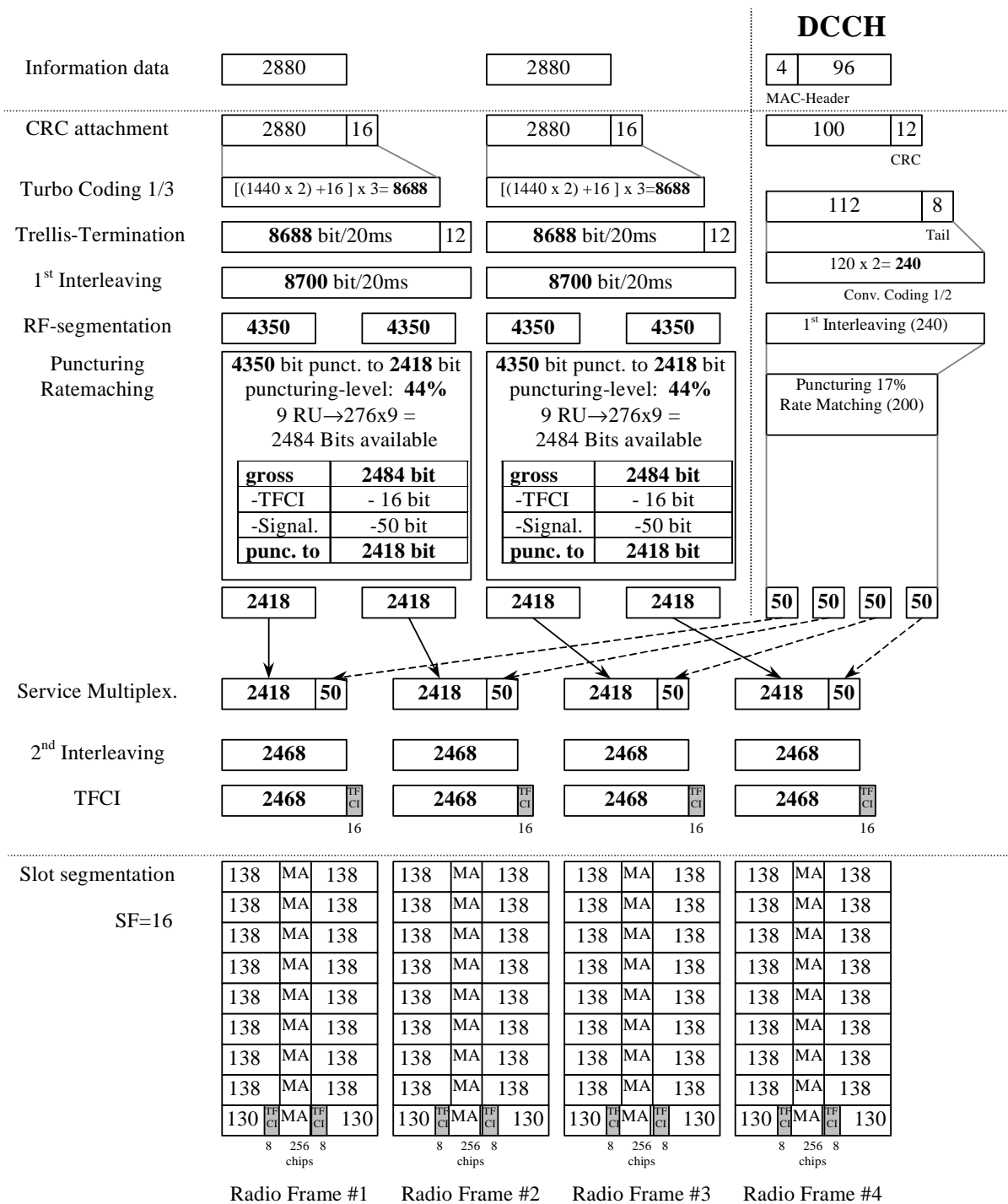

### C.3.4 DL reference measurement channel (384 kbps)

Parameter	
Information data rate	384 kbps
RU's allocated	8*3TS = 24RU
Midamble	256 chips
Interleaving	20 ms
Power control	0 Bit/user
TFCI	16 Bit/user
Inband signalling DCCH	2 kbps
Puncturing level at Code rate : 1/3 DCH / 1/2 DCCH	43.4% / 15.3%

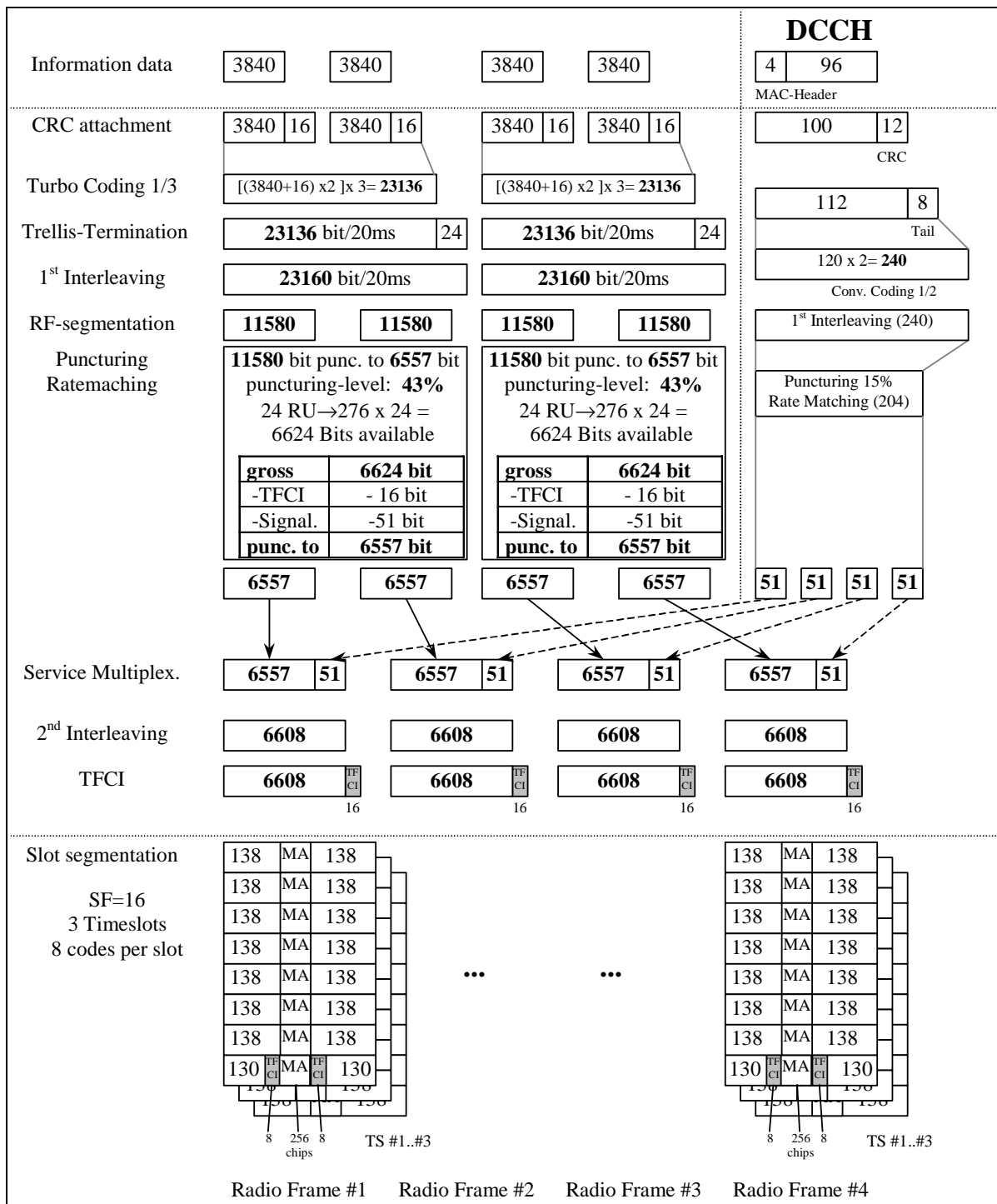

### C.3.5 BCH reference measurement channel

[mapped to 1 code SF16]

Parameter	
Information data rate:	12.3 kbps
RU's allocated	1 RU
Midamble	512 chips
Interleaving	20 ms
Power control	0 bit
TFCI	0 bit
Puncturing level	10%

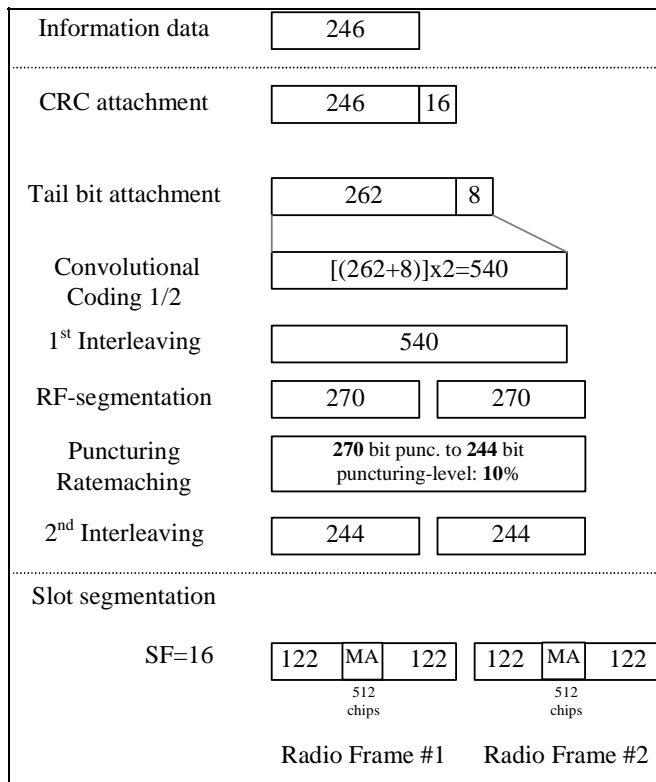

## Annex D (normative): Propagation conditions

### D.1 Test Environments

Table D.1 details the test services, the information data and the propagation conditions.

**Table D.1: Test Environments for UE Performance Specifications**

Test Services	Information Data Rate	Static	Multipath Case 1	Multipath Case 2	Multipath Case 3
		<b>Performance metric</b>			
Paging Message			-	-	-
FACH Message			-	-	-
Circuit Switched Services	12.2 kbps	BLER <	BLER <	BLER <	BLER <
	64 kbps	BLER <	BLER <	BLER <	BLER <
	144 kbps	BLER <	BLER <	BLER <	BLER <
	384 kbps	BLER <	BLER <	BLER <	BLER <
	2048 kbps	BLER <	-	-	-
Packet Switched Data	TBD	TBD	TBD	TBD	TBD

### D.2 Propagation Conditions

#### D.2.1 Static propagation condition

The propagation for the static performance measurement is an Additive White Gaussian Noise (AWGN) environment. No fading and multi-paths exist for this propagation model.

#### D.2.2 Multi-path fading propagation conditions

Table D.2 shows propagation conditions that are used for the performance measurements in multi-path fading environment. All taps have classical Doppler spectrum.

**Table D.2: Propagation Conditions for Multi path Fading Environments**

Case 1, speed 3km/h		Case 2, speed 3 km/h		Case 3, 120 km/h		Case 4, 3 km/h	
Relative Delay [ns]	Average Power [dB]	Relative Delay [ns]	Average Power [dB]	Relative Delay [ns]	Average Power [dB]	Relative Delay [ns]	Average Power [dB]
0	0	0	0	0	0	0	0
976	-10	976	0	260	-3	976	0
		12000	0	521	-6		
				781	-9		

---

## Annex E (normative): Common RF test conditions

### E.1 General

This normative annex specifies the common RF test conditions that are needed for setting a connection and channels that are needed during a connection.

---

### E.2 Connection Set-up

Table E.2 describes the downlink Physical Channels that are required for connection set up.

**Table E.2: Downlink Physical Channels required for connection set-up**

Physical Channel
PSCH
PCCPCH
DPCH
PICH

---

### E.3 During connection

The following clauses describes the uplink and downlink Physical Channels that are transmitted during a connection i.e., when measurements are done.

#### E.3.1 Measurement of Tx Characteristics

Table E.3.1 is applicable for measurements on the Transmitter Characteristics (Clause 5) with the exception of clause 5.2 (UE maximum output power), 5.3 (Frequency Stability), 5.4.1 (Uplink Power Control). For these cases certain parameters are defined individually.

**Table E.3.1.1: Common downlink test condition RF parameters**

Physical Channel	Power
DPCH	-93 dBm Data content PRBS
PSCH	TBD
PCCPCH	TBD
PICH	TBD
OCNS	Nothing

**Table E.3.1.2: Common TX test parameters**

Parameter	Value/description
UL Reference measurement channel	12.2kbps, according to annex C.2.1
Uplink Power Control	SS level and signalling values such that UE transmits maximum power.
Data content	real life (sufficient irregular)

## E.3.2 Measurement of Rx Characteristics

Table E.3.2 is applicable for measurements on the Receiver Characteristics (Clause 6)

**Table E.3.2: Downlink Physical Channels transmitted during a connection.**

Physical Channel	Power
CPICH	TBD
PCCPCH	TBD
SCH	TBD
PICH	TBD
DPCH	TBD

## E.3.3 Measurement of Performance requirements

Table E.3.3 is applicable for measurements on the Performance requirements (Clause 7)

**Table E.3.3: Downlink Physical Channels transmitted during a connection.**

Physical Channel	Power	Note
CPICH	TBD	
PCCPCH	TBD	
SCH	TBD	
PICH	TBD	
DPCH	TBD	
OCNS	TBD	

---

## Annex F (normative): General test conditions and declarations

The requirements of this clause apply to all applicable tests in the present document.

Many of the tests in the present document measure a parameter relative to a value that is not fully specified in the UE specifications. For these tests, the Minimum Requirement is determined relative to a nominal value specified by the manufacturer.

When specified in a test, the manufacturer shall declare the nominal value of a parameter, or whether an option is supported.

In all the relevant clauses in this clause all Bit Error Ratio (BER), Block Error Ratio (BLER) measurements shall be carried out according to the general rules for statistical testing in annex F.6.

---

### F.1 Acceptable uncertainty of Test System

The maximum acceptable uncertainty of the Test System is specified below for each test, where appropriate. The Test System shall enable the stimulus signals in the test case to be adjusted to within the specified range, and the equipment under test to be measured with an uncertainty not exceeding the specified values. All tolerances and uncertainties are absolute values, and are valid for a confidence level of 95 %, unless otherwise stated.

A confidence level of 95% is the measurement uncertainty tolerance interval for a specific measurement that contains 95% of the performance of a population of test equipment.

For RF tests it should be noted that the uncertainties in clause F.1 apply to the Test System operating into a nominal 50 ohm load and do not include system effects due to mismatch between the DUT and the Test System.

#### F.1.1 Measurement of test environments

The measurement accuracy of the UE test environments defined in Annex G, Test environments shall be.

- Pressure  $\pm 5$  kPa.
- Temperature  $\pm 2$  degrees.
- Relative Humidity  $\pm 5$  %.
- DC Voltage  $\pm 1,0$  %.
- AC Voltage  $\pm 1,5$  %.
- Vibration 10 %.
- Vibration frequency 0,1 Hz.

The above values shall apply unless the test environment is otherwise controlled and the specification for the control of the test environment specifies the uncertainty for the parameter.

## F.1.2 Measurement of transmitter

**Table F.1.2 Maximum Test System Uncertainty for transmitter tests**

Clause	Maximum Test System Uncertainty
5.2 UE Maximum Output Power	$\pm 0.7$ dB
5.3 Frequency Stability	$\pm 10$ Hz
5.4.1 Uplink power control	Relative $\pm [0.3]$ dB
5.4.2 Minimum Transmit Power	$\pm 1.0$ dB
5.4.3 Transmit OFF Power	$\pm 1.5$ dB
5.4.4 Transmit ON/OFF Power	TBD
5.4.5 Out-of-synchronisation handling of output power	$\pm 0.4$ dB
5.5.1 Occupied Bandwidth	$\pm 100$ kHz
5.5.2.1 Spectrum emission mask	$\pm 1.5$ dB
5.5.2.2 ACLR	5 MHz offset: $\pm 0.8$ dB 10 MHz offset: $\pm 0.8$ dB
5.5.3 Spurious emissions	$\pm 2.0$ dB for UE and coexistence bands for results > -60 dBm  $\pm 3.0$ dB for results < -60 dBm  Outside above: $f \leq 2.2$ GHz : $\pm 1.5$ dB 2.2 GHz < $f \leq 4$ GHz : $\pm 2.0$ dB $f > 4$ GHz : $\pm 4.0$ dB
5.6 Transmit intermodulation:	Will be based on BS, need to work out freq and level ranges.
5.7.1 Transmit modulation: EVM	$\pm 2.5$ %
5.7.2 Transmit modulation: peak code domain error	$\pm 1$ dB



## F.1.3 Measurement of receiver

**Table F.1.3 Maximum Test System Uncertainty for receiver tests**

Clause	Maximum Test System Uncertainty
6.2 Reference Sensitivity Level	± 0.7 dB
6.3 maximum input level:	TBD
6.4 Adjacent Channel Selectivity (ACS)	Overall system uncertainty ± 1.1 dB
6.5 Blocking Characteristics	Using ± 0.7 dB for signal and interferer as currently defined, and 68 dB ACLR @ 10 MHz. System error with f < 15 MHz offset: ± 1.4 dB  f ≥ 15 MHz offset and f ≤ 2,2 GHz: ±1,0 dB 2,2 GHz < f ≤ 4 GHz : ±1,7 dB f > 4 GHz: ±3,1 dB
6.6 Spurious Response	f < 2,2 GHz: ±1,0dB 2,2 < f < 4GHz: ±1,7dB f > 4 GHz: ±3,1dB
6.7 Intermodulation Characteristics	± 1,3 dB  with Formula = $\sqrt{(2 \cdot CW\_level\_error)^2 + (mod\_level\_error)^2 + (wanted\_signal\_level\_error)^2}$ (Using CW interferer ±0,5 dB, modulated interferer ±0,5 dB, wanted signal ±0,7 dB)
6.8 Spurious Emissions	± 3,0 dB for UE receive band (-78 dBm) Outside above: f ≤ 2,2GHz : ± 2,0dB (-57 dBm) 2,2 GHz < f ≤ 4 GHz : ± 2,0 dB (-47 dBm) f > 4 GHz : ±4,0 dB (-47 dBm)

## F.1.4 Performance requirement

**Table F.1.4 Maximum Test System Uncertainty for Performance Requirements**

Clause	Maximum Test System Uncertainty
TBD	TBD

## F.1.5 Requirements for support of RRM

TBD

---

## F.2 Test Tolerances (This clause is informative)

The Test Tolerances defined in this clause have been used to relax the Minimum Requirements in the present document to derive the Test Requirements.

The Test Tolerances are derived from Test System uncertainties, regulatory requirements and criticality to system performance. As a result, the Test Tolerances may sometimes be set to zero.

The test tolerances should not be modified for any reason e.g. to take account of commonly known test system errors (such as mismatch, cable loss, etc.).

## F.2.1 Transmitter

**Table F.2.1 Test Tolerances for transmitter tests.**

Clause	Test Tolerance
5.2 Maximum Output Power	0,7 dB
5.3 UE Frequency Stability	10 Hz
5.4.1.1 Uplink Power Control, Initial Accuracy	+1,0 dB
5.4.1.2 Uplink Power Control, differential Accuracy	1dB step: 0,1 dB 2 dB step: 0,15 dB 3dB step: 0,2 dB 10 dB step: 0,5 dB 20 dB step: 0,7 dB 30 dB step: 0,7 dB >30 dB step: 1,0 dB
5.4.2 Minimum Transmit Power	1,0 dB
5.4.5 Out-of-synchronisation handling of output power: $\frac{\Sigma DPCH \cdot E_c}{I_{or}}$	0,4 dB
5.4.5 Out-of-synchronisation handling of output power: transmit ON/OFF time	0 ms
5.5.1 Transmit OFF power	1,5 dB
5.5.1 Occupied Bandwidth	0 kHz
5.5.2.1 Spectrum emission mask	1,5 dB
5.5.2.2 Adjacent Channel Leakage Power Ratio (ACLR)	0,8 dB
5.5.3 Spurious Emissions	0 dB
5.6 Transmit Intermodulation	0 dB
5.7.1 Error Vector Magnitude	0%
5.7.2 Peak code domain error	1,0 dB

## F.2.2 Receiver

**Table F.2.2 Test Tolerances for receiver tests.**

Clause	Test Tolerance
6.2 Reference sensitivity level	0.7 dB
6.4 Adjacent channel selectivity	0 dB
6.5 Blocking characteristics	0 dB
6.6 Spurious Response	0 dB
6.7 Intermodulation Characteristics	0 dB
6.8 Spurious emissions	0 dB

## F.2.3 Performance requirements

**Table F.2.3 Test Tolerances for Performance Requirements.**

Clause	Test Tolerance
7.2, Demodulation in Static Propagation Condition	
7.3, Demodulation of DCH in Multiplath Fading conditions	
7.4, Base Station Transmit diversity modes	

## F.2.4 Requirements for support of RRM

TBD

---

## F.3 Interpretation of measurement results

The measurement results returned by the Test System are compared - without any modification - against the Test Requirements as defined by the shared risk principle.

The Shared Risk principle is defined in ETR 273 Part 1 sub-part 2 clause 6.5.

The actual measurement uncertainty of the Test System for the measurement of each parameter shall be included in the test report.

The recorded value for the Test System uncertainty shall be, for each measurement, equal to or lower than the appropriate figure in clause F.1 of the present document.

If the Test System for a test is known to have a measurement uncertainty greater than that specified in clause F.1, it is still permitted to use this apparatus provided that an adjustment is made value as follows.

Any additional uncertainty in the Test System over and above that specified in clause F.1 shall be used to tighten the Test Requirement – making the test harder to pass. (For some tests e.g. receiver tests, this may require modification of stimulus signals). This procedure will ensure that a Test System not compliant with clause F.1 does not increase the chance of passing a device under test where that device would otherwise have failed the test if a Test System compliant with clause F.1 had been used.

---

## F.4 Derivation of Test Requirements (This clause is informative)

The Test Requirements in the present document have been calculated by relaxing the Minimum Requirements of the core specification using the Test Tolerances defined in clause F.2. When the Test Tolerance is zero, the Test Requirement will be the same as the Minimum Requirement. When the Test Tolerance is non-zero, the Test Requirements will differ from the Minimum Requirements, and the formula used for this relaxation is given in table F.4.

Table F.4: Derivation of Test Requirements

Test	Minimum Requirement in TS 25.102	Test Tolerance (TT)	Test Requirement in TS 34.122
5.2 Maximum Output Power	Power single code Power class 2 (24 dBm) Tolerance = +1/-3 dB Power class 3 (21 dBm) Tolerance = +2/-2 dB Power multi code Power class 2 (21 dBm) Tolerance = +1/-3 dB Power class 3 (18 dBm) Tolerance = ±2 dB	0,7 dB	Formula: Upper Tolerance limit + TT Lower Tolerance limit – TT For power class 2 (single and multi): Upper Tolerance limit = +1,7 dB Lower Tolerance limit = -3,7 dB For power class 3 (single and multi): Upper Tolerance limit = +2,7 dB Lower Tolerance limit = -2,7 dB
5.3 UE Frequency Stability	The UE modulated carrier frequency shall be accurate to within ±0.1 ppm compared to the carrier frequency received from the Node B.	10 Hz	Formula: modulated carrier frequency error + TT  modulated carrier frequency error = ±(0.1 ppm + 10 Hz).
5.4.1.1 Uplink Pwer Control, Initial accuracy	± 9dB normal conditions ± 12dB extreme conditions	1.0 dB	Formula: Upper Tolerance limit + TT Lower Tolerance limit – TT Nominal expected TX power ± 10dB (normal conditions) ± 13dB (extreme conditions)
5.4.1.2 Uplink Power Control, differential accuracy	SIR Target      Pow Step Tol <1 dB              0.5 dB <2dB                1 dB <3 dB                1.5 dB <10 dB              2 dB <20dB               4 dB <30 dB               6 dB > 30 dB              9 dB	TT 0.1 dB 0.15 dB 0.2 dB 0.5 dB 0.7 dB 0.7 dB 1.0 dB	Formula: Upper Tolerance limit + TT Lower Tolerance limit – TT
5.4.2 Minimum Transmit Power	UE minimum transmit power shall be less than –44 dBm	1.0 dB	Formula: UE minimum transmit power + TT UE minimum transmit power = –43 dBm
5.4.5 Out-of-synchronisation handling of output power:	$\frac{\Sigma DPCH\_E_c}{I_{or}}$ levels before A –4.6 dB AB: -10 dB BD: -16 dB DE: -12 dB EF: -6 dB transmit ON/OFF time 200ms	0,4 dB for $\frac{\Sigma DPCH\_E_c}{I_{or}}$ 0 ms for timing measuremen t	Formulas: Ratio between A and B + TT Ratio between B and D - TT Ratio between D and E - TT Ratio between E and F + TT transmit ON/OFF time + TT timing  $\frac{\Sigma DPCH\_E_c}{I_{or}}$ levels: Before A: -4.6 AB: -10 + 0,4 dB BD: -16 – 0,4 dB DE: -12 - 0,4 dB EF: -6 + 0,4 dB Uncertainty of OFF power measurement is handled by Transmit OFF power test and uncertainty of ON power measurement is handled by Minimum output power test.transmit ON/OFF time 200ms
5.5.1 Transmit OFF power	Transmit OFF power shall be less than –65 dBm	1.5 dB	Formula: Transmit OFF power + TT Transmit OFF power = –63,5 dBm

5.5.1 Occupied Bandwidth	The occupied channel bandwidth shall be less than 5 MHz based on a chip rate of 3,84 Mcps.	0 kHz	Formula: occupied channel bandwidth: + TT  occupied channel bandwidth = 5,0 MHz		
5.5.2.1 Spectrum emission mask	Minimum requirement defined in TS25.101 table 6.10. The lower limit shall be -50 dBm / 3,84 MHz or which ever is higher.	1.5 dB	Formula: Minimum requirement + TT Lower limit + TT Add 1,5 to Minimum requirement entries in TS25.101 table 6.10 The lower limit shall be -48,5 dBm / 3,84 MHz or which ever is higher.		
5.5.2.2 Adjacent Channel Leakage Power Ratio (ACLR)	Power Classes 2 and 3: UE channel +5 MHz or -5 MHz, ACLR limit: 33 dB UE channel +10 MHz or -10 MHz, ACLR limit: 43 dB	0.8 dB	Formula: ACLR limit - TT Power Classes 2 and 3: UE channel +5 MHz or -5 MHz, ACLR limit: 32,2 dB UE channel +10 MHz or -10 MHz, ACLR limit: 42,2 dB		
5.5.3 Spurious Emissions			Formula: Minimum Requirement+ TT Add zero to all the values of Minimum Requirements in table 5.5.3		
	Frequency Band	Minimum Requirement	Frequency Band	Minimum Requirement	
	9 kHz ≤ f < 150 kHz	-36dBm /1kHz	0 dB	9kHz ≤ f < 1GHz	-36dBm /1kHz
	150 kHz ≤ f < 30 MHz	-36dBm /10kHz	0 dB	150 kHz ≤ f < 30 MHz	-36dBm /10kHz
	30 MHz ≤ f < 1000 MHz	-36dBm /100kHz	0 dB	30 MHz ≤ f < 1000 MHz	-36dBm /100kHz
	1 GHz ≤ f < 12.75 GHz	-30dBm /1MHz	0 dB	1 GHz ≤ f < 2,2 GHz	-30dBm /1MHz
			0 dB	2,2 GHz ≤ f < 4 GHz	-30dBm /1MHz
			0 dB	4 GHz ≤ f < 12,75 GHz	-30dBm /1MHz
	925 MHz < f < 935 MHz	-67dBm /100kHz	0 dB	925 MHz < f < 935 MHz	-67dBm /100kHz
	935 MHz ≤ f ≤ 960 MHz	-79dBm /100kHz	0 dB	935 MHz ≤ f ≤ 960 MHz	-79dBm /100kHz
1805 MHz < f ≤ 1880 MHz	-71dBm /100kHz	0 dB	1805 MHz < f ≤ 1880 MHz	-71dBm /100kHz	
1805 MHz ≤ f ≤ 1880 MHz	-71dBm /100kHz	0 dB	1805 MHz ≤ f ≤ 1880 MHz	-71dBm /100kHz	

5.6 Transmit Intermodulation	Intermodulation Product 5MHz -31 dBc 10MHz -41 dBc	0 dB	Formula: Intermodulation Product + TT Intermodulation Product 5MHz -31 dBc 10MHz -41 dBc	
5.7.1 Error Vector Magnitude	The Error Vector Magnitude shall not exceed 17.5 %	0%	Formula: EVM limit + TT EVM limit = 17,5 %	
5.7.2 Peak code domain error	The peak code domain error shall not exceed -21dB	±1.0 dB	Formula: Peak code domain error + TT Peak code domain error = -20 dB	
6.2 Reference sensitivity level	$I_{or} = -105 \text{ dBm} / 3,84 \text{ MHz}$ BER limit = 0.001	0.7 dB	Formula: $I_{or} + T$ BER limit unchanged  $\hat{I}_{or} = -104,3 \text{ dBm} / 3,84 \text{ MHz}$	
6.4 Adjacent Channel Selectivity	$I_{or} = -91 \text{ dBm} / 3,84 \text{ MHz}$ $I_{oac}(\text{modulated}) = -52 \text{ dBm} / 3,84 \text{ MHz}$ BER limit = 0.001	0 dB	Formula: $I_{or}$ unchanged $I_{oac} - TT$ BER limit unchanged  $I_{oac} = -52 \text{ dBm} / 3,84 \text{ MHz}$	
6.5 Blocking Characteristics	See table 6.5.2a and 6.5.2b in TS 34.122 BER limit = 0,001	0 dB	Formula: $I_{\text{blocking}}(\text{modulated}) - TT$ (dBm/3,84MHz) $I_{\text{blocking}}(\text{CW}) - TT$ (dBm) BER limit unchanged	
6.6 Spurious Response	$I_{\text{blocking}}(\text{CW}) -44 \text{ dBm}$ $F_{uw}$ : Spurious response frequencies BER limit = 0.001	0 dB	Formula: $I_{\text{blocking}}(\text{CW}) - TT$ (dBm) $F_{uw}$ unchanged BER limit unchanged  $I_{\text{blocking}}(\text{CW}) -44 \text{ dBm}$	
6.7 Intermodulation Characteristics	$I_{ow1}(\text{CW}) -46 \text{ dBm}$ $I_{ow2}(\text{modulated}) -46 \text{ dBm} / 3,84 \text{ MHz}$ $F_{uw1}(\text{offset}) 10 \text{ MHz}$ $F_{uw2}(\text{offset}) 20 \text{ MHz}$  BER limit = 0.001	0 dB	Formula: TBD BER limit unchanged.	
6.8 Spurious Emissions			Formula: Maximum level+ TT Add zero to all the values of Maximum Level in table 6.8.1.	
	Frequency Band	Maximum level	Frequency Band	Maximum level
	9kHz ≤ f < 1GHz	-57dBm /100kHz	0 dB	9kHz ≤ f < 1GHz -57dBm /100kHz
	1,9-1,92 GHz 2,01-2.025GHz 2,11-2.170GHz	-60 dBm / 3,84MHz	0 dB	1,9-1,92 GHz 2,01-2.025GHz 2,11-2.170GHz -60 dBm / 3,84MHz
	1 -1,9GHz, 1,92-2,01 GHz 2,025-2,11GHz	-47 dBm/1MHz	0 dB	1 -1,9GHz, 1,92-2,01 GHz 2,025-2,11GHz -47 dBm/1MHz
	1GHz ≤ f ≤ 12,75GHz	-47dBm /1MHz	0 dB	1GHz ≤ f ≤ 2,2GHz -47dBm /1MHz
		0 dB	2,2GHz < f ≤ 4GHz -47dBm /1MHz	
		0 dB	4GHz < f ≤ 12,75GHz -47dBm /1MHz	

## F.5 Acceptable uncertainty of Test Equipment (This clause is informative)

This informative clause specifies the critical parameters of the components of an overall Test System (e.g. Signal generators, Signal Analyzers etc.) which are necessary when assembling a Test System that complies with clause F.1 Acceptable Uncertainty of Test System. These Test Equipment parameters are fundamental to the accuracy of the overall Test System and are unlikely to be improved upon through System Calibration.

### F.5.1 Transmitter measurements

**Table F.5.1 Equipment accuracy for transmitter measurements**

Test	Equipment accuracy	Test conditions
5.2 UE Maximum Output Power	Not applicable	
5.3 Frequency Stability	± 10Hz	
5.4.1 Uplink power control		
5.4.2 Minimum Transmit Power		
5.4.3 Transmit OFF Power		
5.4.4 Transmit ON/OFF Power		
5.4.5 Out-of-synchronisation handling of output power $\frac{DPCCH\_E_c}{I_{or}}$		
5.4.5 Out-of-synchronisation handling of output power: transmit ON/OFF time		
5.5.1 Occupied Bandwidth	100 kHz	
5.5.2.1 Spectrum emission mask	Not applicable	
5.5.2.2 ACLR		
5.5.3 Spurious emissions		
5.5.3 Spurious emissions: additional		
5.6 Transmit intermodulation:	Not applicable	
5.7.1 Transmit modulation: EVM	2.5 %	
5.7.2 Transmit modulation: peak code domain error	±[1 dB]	

### F.5.2 Receiver measurements

**Table F.5.2 Equipment accuracy for receiver measurements**

Clause	Equipment accuracy	Test conditions
6.2 Reference Sensitivity Level	Not applicable	
6.3 maximum input level:	Not applicable	
6.4 Adjacent Channel Selectivity (ACS)	Not applicable	
6.5 Blocking Characteristics	Not applicable	
6.6 Spurious Responce	Not applicable	
6.7 Intermodulation Characteristics	Not applicable	
6.8 Spurious Emissions	Not applicable	

### F.5.3 Performance measurements

**Table G.3 Equipment accuracy for performance measurements**

Clause	Equipment accuracy	Test conditions
TBD	TBD	

## F.6 General rules for statistical testing

[TBD]



# Annex G (normative): Environmental conditions

## G.1 General

This normative annex specifies the environmental requirements of the UE. Within these limits the requirements of the present document shall be fulfilled.

## G.2 Environmental requirements

The requirements in this clause apply to all types of UE(s)

### G.2.1 Temperature

The UE shall fulfil all the requirements in the full temperature range of:

+15°C to +35°C	for normal conditions (with relative humidity of 25 % to 75 %)
-10°C to +55°C	for extreme conditions (see IEC publications 68-2-1 and 68-2-2)

Outside this temperature range the UE, if powered on, shall not make ineffective use of the radio frequency spectrum. In no case shall the UE exceed the transmitted levels as defined in TS 25.101 [1] for extreme operation.

Some tests in the present document are performed also in extreme temperature conditions. These test conditions are denoted as TL (temperature low, -10°C) and TH (temperature high, +55°C).

### G.2.2 Voltage

The UE shall fulfil all the requirements in the full voltage range, i.e. the voltage range between the extreme voltages.

The manufacturer shall declare the lower and higher extreme voltages and the approximate shutdown voltage. For the equipment that can be operated from one or more of the power sources listed below, the lower extreme voltage shall not be higher, and the higher extreme voltage shall not be lower than that specified below.

Power source	Lower extreme voltage	Higher extreme voltage	Normal conditions voltage
AC mains	0,9 * nominal	1,1 * nominal	nominal
Regulated lead acid battery	0,9 * nominal	1,3 * nominal	1,1 * nominal
Non regulated batteries: Leclanché / lithium Mercury/nickel & cadmium	0,85 * nominal 0,90 * nominal	Nominal Nominal	Nominal Nominal

Outside this voltage range the UE if powered on, shall not make ineffective use of the radio frequency spectrum. In no case shall the UE exceed the transmitted levels as defined in [1] TS 25.101 for extreme operation. In particular, the UE shall inhibit all RF transmissions when the power supply voltage is below the manufacturer declared shutdown voltage.

Some tests in the present document are performed also in extreme voltage conditions. These test conditions are denoted as VL (lower extreme voltage) and VH (higher extreme voltage).

## G.2.3 Vibration

The UE shall fulfil all the requirements when vibrated at the following frequency/amplitudes:

<b>Frequency</b>	<b>ASD (Acceleration Spectral Density) random vibration</b>
5 Hz to 20 Hz	0,96 m <sup>2</sup> /s <sup>3</sup>
20 Hz to 500 Hz	0,96 m <sup>2</sup> /s <sup>3</sup> at 20 Hz, thereafter -3 dB/Octave

Outside the specified frequency range the UE, if powered on, shall not make ineffective use of the radio frequency spectrum. In no case shall the UE exceed the transmitted levels as defined in TS 25.101 [1] for extreme operation.

## G.2.4 Specified frequency range

The manufacturer shall declare, which of the frequency bands defined in clause 4.2 is supported by the UE.

Some tests in this TS are performed also in low, mid and high range of the operating frequency band of the UE. The UARFCN's to be used for low, mid and high range are defined in TS 34.108 [3] clause 5.1.1.

## Annex H (normative): Terminal Baseline and Service Implementation Capabilities (TDD)

### H.1 Baseline Implementation Capabilities:

**Table H.1: Baseline implementation capabilities**

Capability TDD	Clause	UE*	Comments
Chip rate 3,84 Mcps		M	
Frequency bands: (uplink and downlink)			
1900-1920 MHz		M	
2010-2025 MHz		M	
1850-1910 MHz		M	
1930-1990 MHz		M	
1910-1930 MHz		M	
Other spectrum		O	As Declared
Carrier raster 200 kHz		M	
UE maximum output power	6.2.1	M	2, 3

(\* M = mandatory, O = optional)

- The special conformance testing functions and the logical test interface as specified in TS 34.109 [3]. This issue is currently under investigation.
- Uplink reference measurement channel 12.2 kbps (FDD), TS 25.102 [1] clause A.2.1.
- Downlink reference measurement channel 12.2 kbps (FDD), TS 25.102 [1] clause A.2.2.

### H.2 Service Implementation Capabilities:

- Downlink reference measurement channel 64 kbps (TDD), TS 25.102 clause A.2.3.
- Downlink reference measurement channel 144 kbps (TDD), TS 25.102 clause A.2.4.
- Down-link reference measurement channel 384 kbps (TDD), TS 25.102 clause A.2.5.
- BCH Reference Measurement Channel.

## Annex I (informative): Change history

Meeting -1st- Level	Doc-1st- Level	CR	Rev	Subject	Cat	Version- Current	Version -New	Doc-2nd- Level
TP-08				Approval of the specification		2.0.0	3.0.0	
TP-09	TP-000134	001		Corrections to EVM and PCDE formulae (B.2.7.1, B2.7.2)	F	3.0.0	3.1.0	T1-000150
TP-10	TP-000217	002		Update of 34.122 according to RAN#9-approved CRs to	F	3.1.0	3.2.0	T1-000256
TP-10	TP-000217	003		Update according to former CRs to 25.102	F	3.1.0	3.2.0	T1-000257
TP-10	TP-000217	004		editorial corrections for: Global In-Channel TX- Test	D	3.1.0	3.2.0	T1-000259
TP-10	TP-000217	005		Handling of measurement uncertainties in UE conformance	F	3.1.0	3.2.0	T1-000262
TP-10	TP-000217	006		Uplink Power control	F	3.1.0	3.2.0	T1-000258
TP-10	TP-000217	007		UE maximum output power multicode	F	3.1.0	3.2.0	T1-000260
TP-10	TP-000217	008		Out-of-synchronisation handling of output power	F	3.1.0	3.2.0	T1-000261
TP-11	TP-010020	009		Test tolerance for 5.7.1 TDD EVM	F	3.2.0	3.3.0	T1-010048
TP-11	TP-010020	010		Test tolerance for 5.7.2 TDD PCDE	F	3.2.0	3.3.0	T1-010049
TP-11	TP-010020	011		Test tolerance for 5.2 Maximum Output Power test case	F	3.2.0	3.3.0	T1-010050
TP-11	TP-010020	012		Test tolerance for 5.3 Frequency Stability	F	3.2.0	3.3.0	T1-010051
TP-11	TP-010020	013		Test tolerance for 5.4.2 Minimum Transmit Output Power	F	3.2.0	3.3.0	T1-010052
TP-11	TP-010020	014		Test Tolerance for 5.4.3 Transmit OFF power	F	3.2.0	3.3.0	T1-010053
TP-11	TP-010020	015		Test tolerance for 5.4.5 Out-of-synchronisation handling of output power	F	3.2.0	3.3.0	T1-010054
TP-11	TP-010020	016		Test tolerance for 5.5.1 Occupied Bandwidth	F	3.2.0	3.3.0	T1-010055
TP-11	TP-010020	017		Test tolerance for 5.5.2.1 Spectrum Emission Mask	F	3.2.0	3.3.0	T1-010056
TP-11	TP-010020	018		Test tolerance for 5.5.2.2 ACLR test case	F	3.2.0	3.3.0	T1-010057
TP-11	TP-010020	019		Test Tolerance for 5.5.3 Spurious emissions	F	3.2.0	3.3.0	T1-010058
TP-11	TP-010020	020		Test Tolerance for 5.6 Transmit Intermodulation	F	3.2.0	3.3.0	T1-010059
TP-11	TP-010020	021		Test Tolerance for 6.2 Reference Sensitivity Level	F	3.2.0	3.3.0	T1-010060
TP-11	TP-010020	022		Test Tolerance for 6.4 Adjacent Channel Selectivity	F	3.2.0	3.3.0	T1-010061
TP-11	TP-010020	023		Test tolerances to 6.5 Blocking Characteristics	F	3.2.0	3.3.0	T1-010062
TP-11	TP-010020	024		Test tolerances to 6.6 Spurious Response	F	3.2.0	3.3.0	T1-010063
TP-11	TP-010020	025		Test tolerances to 6.7 Intermodulation Characteristics	F	3.2.0	3.3.0	T1-010064
TP-11	TP-010020	026		Test Tolerance for 6.5 RX Spurious Emissions	F	3.2.0	3.3.0	T1-010065
TP-11	TP-010020	027		Test tolerance for Annex F in TS34.122	F	3.2.0	3.3.0	T1-010068
TP-11	TP-010020	028		Correction concerning the coexistence of TDD and FDD in the same band	F	3.2.0	3.3.0	T1-010045
TP-11	TP-010020	029		Clarification of the mentioned parameter alpha	F	3.2.0	3.3.0	T1-010046
TP-11	TP-010020	030		Correction concerning the channel number calculation	F	3.2.0	3.3.0	T1-010047
TP-11	TP-010020	031		Correction concerning UE maximum output power classes	F	3.2.0	3.3.0	T1-010066
TP-11	TP-010020	032		Correction of Out-of-Sync criteria	F	3.2.0	3.3.0	T1-010067
TP-12	TP-010120	033		CR:New Power Classes require new test tolerances	F	3.3.0	3.4.0	T1-010154
TP-12	TP-010120	034		CR:Test tolerances for Output Power Dynamic	F	3.3.0	3.4.0	T1-010155
TP-13	TP-010185	036		Replacement of Conformance requirements by Minimum requirements	F	3.4.0	3.5.0	T1-010345
TP-13	TP-010185	037		Deletion of the test: Demodulation of BCH in Block STTD mode	F	3.4.0	3.5.0	T1-010344
TP-13	TP-010185	038		Test conditions	F	3.4.0	3.5.0	T1-010347
TP-13	TP-010185	039		Completion of test procedures & test system uncertainties	F	3.4.0	3.5.0	T1-010349
TP-13	TP-010185	040		Maximum Test System Uncertainty for transmitter tests	F	3.4.0	3.5.0	T1-010351
TP-13	TP-010185	041		Correction of Out-of-synchronisation test	F	3.4.0	3.5.0	T1-010353
TP-13	TP-010185	042		UE power classes	F	3.4.0	3.5.0	T1-010354
TP-13	TP-010185	043		Correction of frequency range for receiver spurious emission requirements	F	3.4.0	3.5.0	T1-010365

---

## History

<b>Document history</b>		
V3.0.0	August 2000	Publication
V3.1.0	November 2000	Publication
V3.2.0	February 2001	Publication
V3.3.0	April 2001	Publication
V3.4.0	June 2001	Publication
V3.5.0	September 2001	Publication