

ETSI TS 136 112 V12.0.0 (2014-10)



**LTE;
Location Measurement Unit (LMU) conformance specification;
Network based positioning systems in Evolved
Universal Terrestrial Radio Access Network (E-UTRAN)
(3GPP TS 36.112 version 12.0.0 Release 12)**



ReferenceRTS/TSGR-0436112vc00

Keywords

LTE

ETSI

650 Route des Lucioles
F-06921 Sophia Antipolis Cedex - FRANCE

Tel.: +33 4 92 94 42 00 Fax: +33 4 93 65 47 16

Siret N° 348 623 562 00017 - NAF 742 C
Association à but non lucratif enregistrée à la
Sous-Préfecture de Grasse (06) N° 7803/88

Important notice

The present document can be downloaded from:

<http://www.etsi.org>

The present document may be made available in electronic versions and/or in print. The content of any electronic and/or print versions of the present document shall not be modified without the prior written authorization of ETSI. In case of any existing or perceived difference in contents between such versions and/or in print, the only prevailing document is the print of the Portable Document Format (PDF) version kept on a specific network drive within ETSI Secretariat.

Users of the present document should be aware that the document may be subject to revision or change of status. Information on the current status of this and other ETSI documents is available at

<http://portal.etsi.org/tb/status/status.asp>

If you find errors in the present document, please send your comment to one of the following services:

http://portal.etsi.org/chaicor/ETSI_support.asp

Copyright Notification

No part may be reproduced or utilized in any form or by any means, electronic or mechanical, including photocopying and microfilm except as authorized by written permission of ETSI.

The content of the PDF version shall not be modified without the written authorization of ETSI.

The copyright and the foregoing restriction extend to reproduction in all media.

© European Telecommunications Standards Institute 2014.

All rights reserved.

DECT™, **PLUGTESTS™**, **UMTS™** and the ETSI logo are Trade Marks of ETSI registered for the benefit of its Members. **3GPP™** and **LTE™** are Trade Marks of ETSI registered for the benefit of its Members and of the 3GPP Organizational Partners.

GSM® and the GSM logo are Trade Marks registered and owned by the GSM Association.

Intellectual Property Rights

IPRs essential or potentially essential to the present document may have been declared to ETSI. The information pertaining to these essential IPRs, if any, is publicly available for **ETSI members and non-members**, and can be found in ETSI SR 000 314: *"Intellectual Property Rights (IPRs); Essential, or potentially Essential, IPRs notified to ETSI in respect of ETSI standards"*, which is available from the ETSI Secretariat. Latest updates are available on the ETSI Web server (<http://ipr.etsi.org>).

Pursuant to the ETSI IPR Policy, no investigation, including IPR searches, has been carried out by ETSI. No guarantee can be given as to the existence of other IPRs not referenced in ETSI SR 000 314 (or the updates on the ETSI Web server) which are, or may be, or may become, essential to the present document.

Foreword

This Technical Specification (TS) has been produced by ETSI 3rd Generation Partnership Project (3GPP).

The present document may refer to technical specifications or reports using their 3GPP identities, UMTS identities or GSM identities. These should be interpreted as being references to the corresponding ETSI deliverables.

The cross reference between GSM, UMTS, 3GPP and ETSI identities can be found under <http://webapp.etsi.org/key/queryform.asp>.

Modal verbs terminology

In the present document "**shall**", "**shall not**", "**should**", "**should not**", "**may**", "**may not**", "**need**", "**need not**", "**will**", "**will not**", "**can**" and "**cannot**" are to be interpreted as described in clause 3.2 of the [ETSI Drafting Rules](#) (Verbal forms for the expression of provisions).

"**must**" and "**must not**" are **NOT** allowed in ETSI deliverables except when used in direct citation.

Contents

Intellectual Property Rights	2
Foreword.....	2
Modal verbs terminology.....	2
Foreword.....	7
1 Scope	8
2 References	8
3 Definitions, symbols and abbreviations	8
3.1 Definitions	8
3.2 Symbols.....	8
3.3 Abbreviations	9
4 General Test Conditions and Declarations	9
4.1 Measurement uncertainties and test requirements	9
4.1.1 General.....	9
4.1.2 Acceptable uncertainty of Test System.....	9
4.1.2.1 Measurement of receiver	9
4.1.2.2 Measurement time requirement.....	14
4.1.2.3 Measurement of performance requirement	14
4.2 LMU classes.....	14
4.3 Regional requirements.....	14
4.4 Selection of configurations for testing.....	14
4.5 LMU configurations	14
4.6 Manufacturer's declarations of regional requirements.....	16
4.6.1 Operating band and frequency range	16
4.6.2 Channel bandwidth	16
4.6.3 Co-location with base stations in other bands.....	16
4.6.4 Manufacturer's declarations of supported RF configurations	17
4.7 Specified frequency range and supported channel bandwidth.....	17
4.7.1 RF bandwidth position for non-single carrier testing	17
4.7.2 Aggregated channel bandwidth position for CA specific testing.....	18
4.8 Format and interpretation of tests.....	18
5 Operating Bands and Channel Arrangement	19
5.1 General	19
5.2 Operating bands.....	19
5.3 Channel bandwidth.....	21
5.4 Channel arrangement.....	22
5.4.1 Channel spacing.....	22
5.4.2 CA Channel spacing	22
5.4.3 Channel raster	22
5.4.4 Carrier frequency and EARFCN.....	23
5.5 Requirements for contiguous spectrum	24
6 Conformance Tests for LMU RF Requirements	25
6.1 General	25
6.2 Reference sensitivity level.....	25
6.2.1 Definition and applicability	25
6.2.2 Minimum requirement	25
6.2.3 Test Purpose.....	25
6.2.4 Method of testing	25
6.2.4.1 Initial conditions	25
6.2.4.2 Procedure	25
6.2.5 Test requirement	25
6.3 Dynamic range	26

6.3.1	Definition and applicability	26
6.3.2	Minimum Requirement	26
6.3.3	Test purpose.....	26
6.3.4	Method of testing	26
6.3.4.1	Initial conditions	26
6.3.4.2	Procedure	26
6.3.5	Test Requirements	27
6.4	In-channel selectivity	27
6.4.1	Definition and applicability	27
6.4.2	Minimum Requirement	27
6.4.3	Test purpose.....	27
6.4.4	Method of testing	27
6.4.4.1	Initial conditions	27
6.4.4.2	Procedure	28
6.4.5	Test Requirements	28
6.5	Adjacent channel selectivity (ACS) and narrow-band blocking.....	28
6.5.1	Definition and applicability	28
6.5.2	Minimum Requirement	28
6.5.3	Test purpose.....	29
6.5.4	Method of test	29
6.5.4.1	Initial conditions	29
6.5.4.2	Procedure	29
6.5.4.3	Procedure for narrow-band blocking.....	29
6.5.5	Test Requirements	29
6.6	Blocking	30
6.6.1	Definition and applicability	30
6.6.2	Minimum Requirements	30
6.6.3	Test purpose.....	31
6.6.4	Method of test	31
6.6.4.1	Initial conditions	31
6.6.4.2	Procedure	31
6.6.5	Test Requirements	31
6.7	Receiver spurious emissions.....	32
6.7.1	Definition and applicability	32
6.7.2	Minimum Requirements	33
6.7.3	Test purpose.....	33
6.7.4	Method of test	33
6.7.4.1	Initial conditions	33
6.7.4.2	Procedure	33
6.7.5	Test requirements.....	33
6.8	Receiver intermodulation	34
6.8.1	Definition and applicability	34
6.8.2	Minimum Requirement	34
6.8.3	Test purpose.....	34
6.8.4	Method of test	34
6.8.4.1	Initial conditions	34
6.8.4.2	Procedures.....	34
6.8.5	Test requirements.....	34
7	Conformance Tests for UL RTOA Measurement Time Requirements.....	35
7.1	General	35
7.2	Requirements for FDD without DRX.....	35
7.2.1	Definition and applicability	35
7.2.2	Minimum requirement	35
7.2.3	Test Purpose.....	35
7.2.4	Method of testing	35
7.2.4.1	Initial conditions	35
7.2.4.2	Procedure	36
7.2.5	Test requirement	36
7.3	Requirements for TDD without DRX	36
7.3.1	Definition and applicability	36
7.3.2	Minimum requirement	36

7.3.3	Test Purpose.....	36
7.3.4	Method of testing	36
7.3.4.1	Initial conditions	36
7.3.4.2	Procedure	37
7.3.5	Test requirement	37
7.4	UL RTOA Measurements upon Receiving SRS Configuration Update.....	37
7.4.1	Definition and applicability	37
7.4.2	Minimum requirement	37
7.4.3	Test Purpose.....	37
7.4.4	Method of testing	37
7.4.4.1	Initial conditions	37
7.4.4.2	Procedure	37
7.4.5	Test requirement	38
8	Conformance Tests for UL RTOA Measurement Accuracy Requirements.....	38
8.1	General	38
8.2	UL RTOA measurement accuracy for a UE not configured with CA.....	38
8.2.1	Definition and applicability	38
8.2.2	Minimum requirement	38
8.2.3	Test Purpose.....	38
8.2.4	Method of testing	38
8.2.4.1	Initial conditions	38
8.2.4.2	Procedure	38
8.2.5	Test requirement	39
8.3	UL RTOA measurement accuracy for a UE configured with CA.....	39
8.3.1	Definition and applicability	39
8.3.2	Minimum requirement	39
8.3.3	Test Purpose.....	39
8.3.4	Method of testing	39
8.3.4.1	Initial conditions	39
8.3.4.2	Procedure	40
8.3.5	Test requirement	40
8.4	Parallel UL RTOA measurements on the same carrier frequency.....	40
8.4.1	Definition and applicability	40
8.4.2	Minimum requirement	40
8.4.3	Test Purpose.....	41
8.4.4	Method of testing	41
8.4.4.1	Initial conditions	41
8.4.4.2	Procedure	41
8.4.5	Test requirement	41
8.5	Parallel UL RTOA measurements on two carrier frequencies	42
8.5.1	Definition and applicability	42
8.5.2	Minimum requirement	42
8.5.3	Test Purpose.....	42
8.5.4	Method of testing	42
8.5.4.1	Initial conditions	42
8.5.4.2	Procedure	42
8.5.5	Test requirement	42
Annex A (informative): Reference measurement channel.....		44
A.1	Reference measurement channel	44
Annex B (informative): Propagation conditions.....		48
B.1	Static Propagation condition	48
B.2	Multi-path fading propagation conditions	48
Annex C (informative): Characteristics of the interfering signals.....		49
C.1	Interfering signals in LMU RF tests	49
C.2	Interfering signals in LMU performance tests	49

Annex D (informative):	Environmental requirements for the LMU equipment	50
D.1	General	50
D.2	Normal test environment	50
D.3	Extreme test environment.....	50
D.3.1	Extreme temperature	50
D.4	Vibration.....	51
D.5	Power supply	51
D.6	Measurement of test environments.....	51
Annex E (informative):	General Rules for statistical testing	52
E.1	Error Definition	52
E.2	Test Method.....	52
Annex F (informative):	Test tolerances and derivation of test requirements	53
F.1	Test tolerances and derivation of test requirements	53
Annex G (informative):	Measurement system setup	56
G.1	Receiver RF Requirements Testing.....	56
G.1.1	Receiver sensitivity level.....	56
G.1.2	Dynamic range	56
G.1.3	In-channel selectivity	57
G.1.4	Adjacent channel selectivity (ACS) and narrow-band blocking.....	57
G.1.5	Blocking	58
G.1.6	Receiver spurious emissions.....	58
G.1.7	Receiver intermodulation	59
G.2	UL RTOA measurement time requirements Testing.....	59
G.2.1	UL RTOA measurement time, FDD without DRX	59
G.2.2	UL RTOA measurement time, TDD without DRX.....	60
G.3	UL RTOA measurement accuracy requirements Testing	60
G.3.1	UL RTOA measurement accuracy for a UE not configured with CA	60
G.3.2	UL RTOA measurement accuracy for a UE configured with CA	60
G.3.3	UL RTOA measurement accuracy when LMU is performing multiple UL RTOA measurements in parallel.....	61
Annex H (informative):	Change history	62
History	63

Foreword

This Technical Specification has been produced by the 3rd Generation Partnership Project (3GPP).

The contents of the present document are subject to continuing work within the TSG and may change following formal TSG approval. Should the TSG modify the contents of the present document, it will be re-released by the TSG with an identifying change of release date and an increase in version number as follows:

Version x.y.z

where:

- x the first digit:
 - 1 presented to TSG for information;
 - 2 presented to TSG for approval;
 - 3 or greater indicates TSG approved document under change control.
- y the second digit is incremented for all changes of substance, i.e. technical enhancements, corrections, updates, etc.
- z the third digit is incremented when editorial only changes have been incorporated in the document.

1 Scope

The present document establishes the conformance requirements for E-UTRAN Location Measurement Units (LMU) operating in the FDD or TDD mode.

2 References

The following documents contain provisions which, through reference in this text, constitute provisions of the present document.

- References are either specific (identified by date of publication, edition number, version number, etc.) or non-specific.
- For a specific reference, subsequent revisions do not apply.
- For a non-specific reference, the latest version applies. In the case of a reference to a 3GPP document (including a GSM document), a non-specific reference implicitly refers to the latest version of that document *in the same Release as the present document*.

- [1] 3GPP TR 21.905: "Vocabulary for 3GPP Specifications".
- [2] 3GPP TS 36.111: "Location Measurement Unit (LMU) performance specification".
- [3] 3GPP TS 36.211: "Physical channels and modulation".
- [4] IEC 60721-3-3 (2002): "Classification of environmental conditions - Part 3: Classification of groups of environmental parameters and their severities - Section 3: Stationary use at weather protected locations".
- [5] IEC 60721-3-4 (1995): "Classification of environmental conditions - Part 3: Classification of groups of environmental parameters and their severities - Section 4: Stationary use at non-weather protected locations".
- [6] IEC 60068-2-1 (2007): "Environmental testing - Part 2: Tests. Tests A: Cold".
- [7] IEC 60068-2-2 (2007): "Environmental testing - Part 2: Tests. Tests B: Dry heat".
- [8] IEC 60068-2-6 (2007): "Environmental testing - Part 2: Tests - Test Fc: Vibration (sinusoidal)".

3 Definitions, symbols and abbreviations

3.1 Definitions

For the purposes of the present document, the terms and definitions given in TR 21.905 [1] and the following apply. A term defined in the present document takes precedence over the definition of the same term, if any, in TR 21.905 [1].

3.2 Symbols

For the purposes of the present document, the following symbols apply:

BWChannel	Channel bandwidth
BWChannel_CA	Aggregated Channel bandwidth
\hat{E}_s	Received energy per RE (power normalized to the subcarrier spacing) during the useful part of the symbol, i.e. excluding the cyclic prefix, at the LMU antenna connector
Fedge_high	Upper edge of the Aggregated Channel Bandwidth
Fedge_low	Lower edge of the Aggregated Channel Bandwidth

I_o	The total received power density, including signal and interference, as measured at the UE antenna connector
I_{ot}	The received power spectral density of the total noise and interference for a certain RE (power integrated over the RE and normalized to the subcarrier spacing) as measured at the LMU antenna connector
T_s	The basic unit of time defined in TS 36.211 clause 4

3.3 Abbreviations

For the purposes of the present document, the abbreviations given in TR 21.905 [1] and the following apply. An abbreviation defined in the present document takes precedence over the definition of the same abbreviation, if any, in TR 21.905 [1].

ACS	Adjacent Channel Selectivity
DRX	Discontinuous Reception
E-UTRAN	Evolved Universal Terrestrial Radio Access Network
E-SMLC	Enhanced Serving Mobile Location Center
EARFCN	E-UTRAN Absolute Radio Frequency Channel Number
eNodeB	evolved Node B
LMU	Location Measurement Unit
RTOA	Relative Time of Arrival
SRS	Sounding Reference Signal
UE	User Equipment
UL	Uplink
UTDOA	Uplink Time Difference Of Arrival

4 General Test Conditions and Declarations

4.1 Measurement uncertainties and test requirements

4.1.1 General

The requirements of this clause apply to all applicable tests in this specification.

The Minimum Requirements are given in 36.111 [2] and test requirements are given in this specification. Test Tolerances are defined in Annex F of this specification. Test Tolerances are individually calculated for each test. The Test Tolerances are used to relax the Minimum Requirements in 36.111 [2] to create Test Requirements.

4.1.2 Acceptable uncertainty of Test System

The maximum acceptable uncertainty of the Test System is specified below for each test, where appropriate. The Test System shall enable the stimulus signals in the test case to be adjusted to within the specified tolerance and the equipment under test to be measured with an uncertainty not exceeding the specified values. All tolerances and uncertainties are absolute values, and are valid for a confidence level of 95 %, unless otherwise stated.

A confidence level of 95% is the measurement uncertainty tolerance interval for a specific measurement that contains 95% of the performance of a population of test equipment.

For RF tests in Section 6, it should be noted that the uncertainties in subclause 4.1.2 apply to the Test System operating into a nominal 50 ohm load and do not include system effects due to mismatch between the LMU and the Test System.

4.1.2.1 Measurement of receiver

Table 4.1.2-1: Maximum Test System Uncertainty for receiver tests

Subclause	Maximum Test System Uncertainty ¹	Derivation of Test System Uncertainty
-----------	--	---------------------------------------

6.2 Reference sensitivity level	±0.7 dB, $f \leq 3.0\text{GHz}$ ±1.0 dB, $3.0\text{GHz} < f \leq 4.2\text{GHz}$	
6.3 Dynamic range	±0.3 dB	Overall system uncertainty for static conditions is equal to signal-to-noise ratio uncertainty. Signal-to-noise ratio uncertainty ±0.3 dB Definitions of signal-to-noise ratio, AWGN and related constraints are given in Table 4.1.2-3.
6.4 In-channel selectivity	±1.4 dB, $f \leq 3.0\text{GHz}$ ±1.8 dB, $3.0\text{GHz} < f \leq 4.2\text{GHz}$	Overall system uncertainty comprises three quantities: 1. Wanted signal level error 2. Interferer signal level error 3. Additional impact of interferer leakage Items 1 and 2 are assumed to be uncorrelated so can be root sum squared to provide the ratio error of the two signals. The interferer leakage effect is systematic, and is added arithmetically. Test System uncertainty = $[\text{SQRT}(\text{wanted_level_error}^2 + \text{interferer_level_error}^2)] + \text{leakage effect.}$ $f \leq 3.0\text{GHz}$ Wanted signal level ± 0.7dB Interferer signal level ± 0.7dB $3.0\text{GHz} < f \leq 4.2\text{GHz}$ Wanted signal level ± 1.0dB Interferer signal level ± 1.0dB $f \leq 4.2\text{GHz}$ Impact of interferer leakage 0.4dB.

<p>6.5 Adjacent Channel Selectivity (ACS) and narrow-band blocking</p>	<p>± 1.4 dB, $f \leq 3.0$GHz ± 1.8 dB, 3.0GHz $< f \leq 4.2$GHz</p>	<p>Overall system uncertainty comprises three quantities: 1. Wanted signal level error 2. Interferer signal level error 3. Additional impact of interferer ACLR Items 1 and 2 are assumed to be uncorrelated so can be root sum squared to provide the ratio error of the two signals. The interferer ACLR effect is systematic, and is added arithmetically. Test System uncertainty = [SQRT (wanted_level_error² + interferer_level_error²)] + ACLR effect. $f \leq 3.0$GHz Wanted signal level ± 0.7dB Interferer signal level ± 0.7dB 3.0GHz $< f \leq 4.2$GHz Wanted signal level ± 1.0dB Interferer signal level ± 1.0dB $f \leq 4.2$GHz Impact of interferer ACLR 0.4dB. See Note 2.</p>
--	--	---

<p>6.6 Blocking (General requirements)</p>	<p><u>In-band blocking, using modulated interferer:</u> ± 1.6 dB, $f \leq 3.0$GHz ± 2.0 dB, 3.0GHz $< f \leq 4.2$GHz</p> <p><u>Out of band blocking, using CW interferer:</u> 1MHz $< f_{\text{interferer}} \leq 3$ GHz: ± 1.3 dB 3.0GHz $< f_{\text{interferer}} \leq 4.2$ GHz: ± 1.6 dB 4.2GHz $< f_{\text{interferer}} \leq 12.75$ GHz: ± 3.2 dB</p>	<p>Overall system uncertainty can have these contributions: 1. Wanted signal level error 2. Interferer signal level error 3. Interferer ACLR 4. Interferer broadband noise Items 1 and 2 are assumed to be uncorrelated so can be root sum squared to provide the ratio error of the two signals. The Interferer ACLR or Broadband noise effect is systematic, and is added arithmetically. Test System uncertainty = [SQRT (wanted_level_error² + interferer_level_error²)] + ACLR effect + Broadband noise effect.</p> <p><u>In-band blocking, using modulated interferer:</u> $f \leq 3.0$GHz Wanted signal level ± 0.7dB Interferer signal level ± 1.0dB 3.0GHz $< f \leq 4.2$GHz Wanted signal level ± 1.0dB Interferer signal level ± 1.2dB</p> <p>$f \leq 4.2$GHz Interferer ACLR 0.4dB Broadband noise not applicable</p> <p><u>Out of band blocking, using CW interferer:</u> Wanted signal level: ± 0.7dB $f \leq 3.0$GHz ± 1.0dB 3.0GHz $< f \leq 4.2$GHz Interferer signal level: ± 1.0dB up to 3GHz ± 1.2dB 3.0GHz $< f \leq 4.2$GHz ± 3.0dB up to 12.75GHz Interferer ACLR not applicable Impact of interferer Broadband noise 0.1dB</p>
<p>6.7 Receiver spurious emissions</p>	<p>30 MHz $\leq f \leq 4$ GHz: ± 2.0 dB 4 GHz $< f \leq 19$ GHz: ± 4.0 dB</p>	

6.8 Receiver intermodulation	± 1.8 dB, $f \leq 3.0$ GHz ± 2.4 dB, 3.0 GHz $< f \leq 4.2$ GHz	<p>Overall system uncertainty comprises four quantities:</p> <ol style="list-style-type: none"> 1. Wanted signal level error 2. CW Interferer level error 3. Modulated Interferer level error 4. Impact of interferer ACLR <p>The effect of the closer CW signal has twice the effect. Items 1, 2 and 3 are assumed to be uncorrelated so can be root sum squared to provide the combined effect of the three signals. The interferer ACLR effect is systematic, and is added arithmetically.</p> <p>Test System uncertainty = $\text{SQRT} [(2 \times \text{CW_level_error})^2 + (\text{mod interferer_level_error})^2 + (\text{wanted signal_level_error})^2]$ + ACLR effect.</p> <p>$f \leq 3.0$GHz Wanted signal level ± 0.7dB CW Interferer level ± 0.5dB Mod Interferer level ± 0.7dB 3.0GHz $< f \leq 4.2$GHz Wanted signal level ± 1.0dB CW Interferer level ± 0.7dB Mod Interferer level ± 1.0dB</p> <p>$f \leq 4.2$GHz Impact of interferer ACLR 0.4dB</p>
<p>Note 1: Unless otherwise noted, only the Test System stimulus error is considered here. The effect of errors in the throughput measurements due to finite test duration is not considered.</p> <p>Note 2: The Test equipment ACLR requirement for a specified uncertainty contribution is calculated as below:</p> <ol style="list-style-type: none"> a) The wanted signal to noise ratio for Reference sensitivity is calculated based on a 5dB noise figure b) The same wanted signal to (noise + interference) ratio is then assumed at the desensitisation level according to the ACS test conditions c) The noise is subtracted from the total (noise + interference) to compute the allowable LMU adjacent channel interference. From this an equivalent LMU ACS figure can be obtained d) The contribution from the Test equipment ACLR is calculated to give a 0.4dB additional rise in interference. This corresponds to a Test equipment ACLR which is 10.2 dB better than the LMU ACS e) This leads to the following Test equipment ACLR requirements for the interfering signal: <p><u>Adjacent channel Selectivity</u> E-UTRA 1.4MHz channel bandwidth: 56dB E-UTRA 3MHz channel bandwidth: 56dB E-UTRA 5MHz channel bandwidth and above: 56dB</p> <p><u>Narrow band blocking</u> E-UTRA 1.4MHz channel bandwidth: 65dB E-UTRA 3MHz channel bandwidth: 61dB E-UTRA 5MHz channel bandwidth and above: 59dB</p>		

4.1.2.2 Measurement time requirement

Table 4.1.2.2-1 UL RTOA Measurement time uncertainty

Test parameter	Uncertainty	Notes
Measurement time, T_e	0 s	Requires the time stamp clock accuracy ≤ 1 ppm

4.1.2.3 Measurement of performance requirement

Table 4.1.2.3-1 UL RTOA Measurement accuracy uncertainty

Test parameter	Uncertainty	Notes
UL RTOA measurement accuracy	0 s	Requires calibration of the signal path delay to be ± 10 ns
Wanted Signal input SINR	± 0.3 dB	Signal generators with integral AWGN sources. Interferer modeled as AWGN

4.2 LMU classes

The UTDOA architecture is described in TS 36.305 [2].

An LMU may be deployed in three ways:

- LMU class 1: LMU integrated into base station
- LMU class 2: LMU co-sited with base station and sharing antenna with the base station
- LMU class 3: standalone LMU with own receive antenna

4.3 Regional requirements

Some requirements in the present document may only apply in certain regions either as optional requirements or set by local and regional regulation as mandatory requirements. It is normally not stated in the 3GPP specifications under what exact circumstances that the requirements apply, since this is defined by local or regional regulation.

Table 4.3-1 lists all requirements that may be applied differently in different regions.

Table 4.3-1: List of regional requirements

Clause number	Requirement	Comments
5.5	Operating bands	Some bands may be applied regionally.
5.6	Channel bandwidth	Some channel bandwidths may be applied regionally.
5.7	Channel arrangement	The requirement is applied according to what operating bands in Clause 5.5 that are supported by the LMU.

4.4 Selection of configurations for testing

The tests in this specification do not cover all possible configurations.

4.5 LMU configurations

Receiver test ports for LMU class 1 are illustrated in Figure 4.5-1. Receiver test ports for LMU class 2 are illustrated in Figure 4.5-2. Receiver test ports for LMU class 3 are illustrated in Figure 4.5-3. If any external apparatus, e.g., a RX

amplifier, a filter or the combination of such devices is used, LMU RF requirements specified in this specification apply at the far end antenna connector (port B); otherwise, the requirements apply at port A.

Requirements applicability for different LMU classes is summarized in Table 4.5-1.

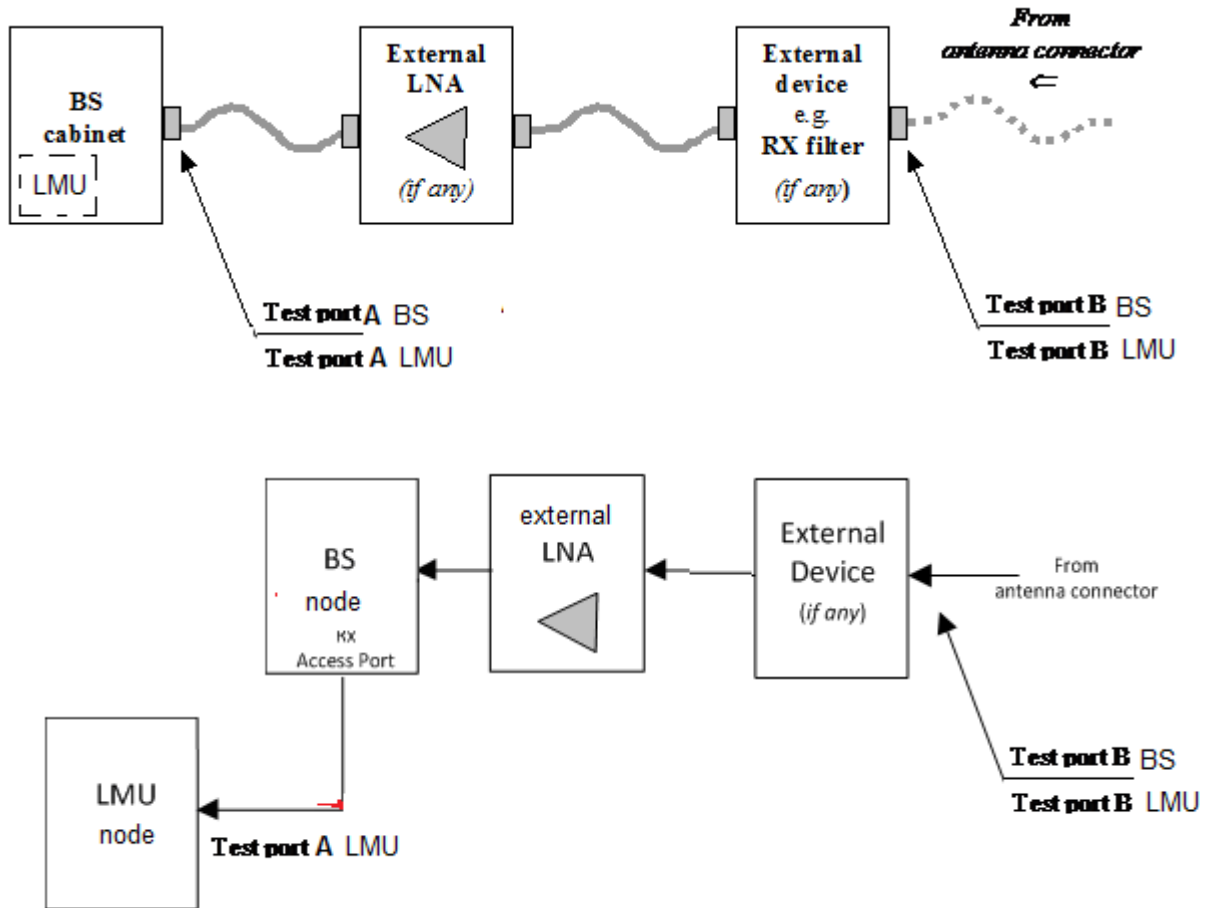

Figure 4.5-1: Two examples of receiver test ports for LMU class 1.

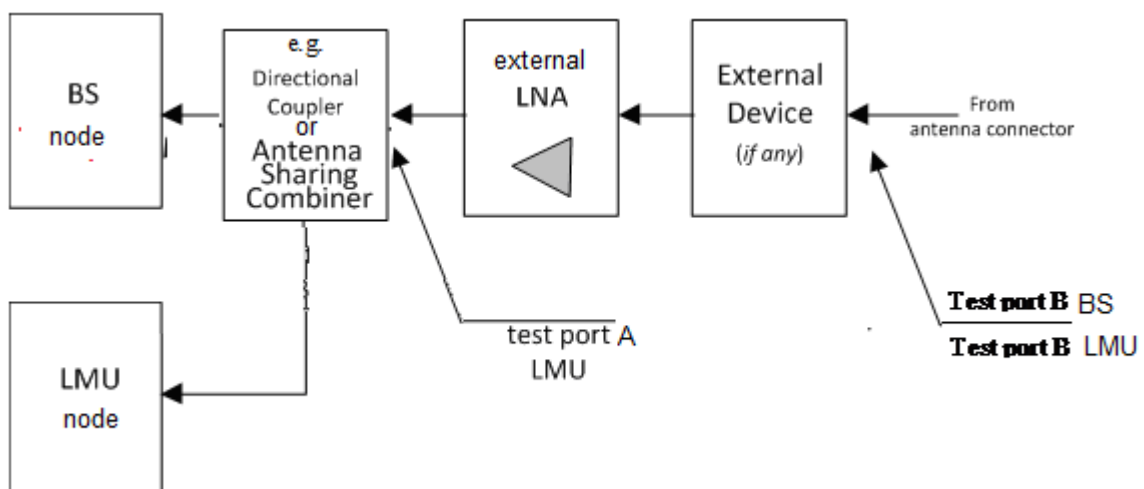

Figure 4.5-2: Receiver test ports for LMU class 2.

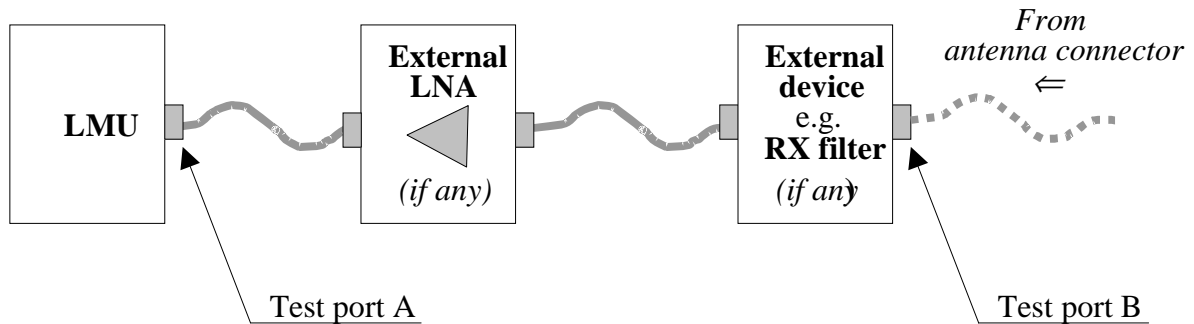

Figure 4.5-3: Receiver test ports for LMU class 3.

Table 4.5-1: Test ports and RF requirements applicability

LMU class	Physical Node	RF Requirements	Test Port	Comments
1	BS	TS 36.104	A or B	Test port determined per TS 36.104
2	BS	Degradation of the base station DL performance and base station UL performance may occur when LMU class 2 is co-sited with the base station.	B	Test port determined per TS 36.104
	LMU	clauses 5.2-5.8	A or B	Test port determined per Figure 4.5-2
3	LMU	clauses 5.2-5.8	A or B	Test port determined per Figure 4.5-3

4.6 Manufacturer's declarations of regional requirements

4.6.1 Operating band and frequency range

The manufacturer shall declare which operating band(s) specified in clause 5.5 that is supported by the LMU under test and if applicable, which frequency ranges within the operating band(s) that the LMU can operate in. Requirements for other operating bands and frequency ranges need not be tested.

The manufacturer shall declare which operating band(s) specified in clause 5.5 are supported by the LMU under test for UEs configured with carrier aggregation.

4.6.2 Channel bandwidth

The manufacturer shall declare which of the channel bandwidths specified in TS36.111 [TBD] subclause TBD that are supported by the LMU under test. Requirements for other channel bandwidths need not be tested.

4.6.3 Co-location with base stations in other bands

The manufacturer shall declare whether the LMU under test is intended to operate co-located with base stations of one or more of the systems GSM850, GSM900, DCS1800, PCS1900, UTRA FDD, UTRA TDD and/or E-UTRA operating in another band. If this is the case, at least

- LMU receiver spurious emissions need to be tested, and
- compliance with the applicable test requirements for base station receiver blocking in TS 36.141 shall be tested.

Additionally, for LMU Class 2, due to the expected base station performance degradation (see Table 4.5-1), the base station performance needs to be ensured for UL and DL.

4.6.4 Manufacturer's declarations of supported RF configurations

The manufacturer shall declare which operational configurations the LMU supports by declaring the following parameters:

- The supported operating bands defined in subclause 5.5;
- The frequency range within the above operating band(s) supported by the LMU;
- The maximum RF bandwidth supported by a LMU within each operating band;
 - for contiguous spectrum operation
- The supported operating configurations (multi-carrier, carrier aggregation, and/or single carrier) within each operating band.
- The supported component carrier combinations at nominal channel spacing within each operating band and sub-block.
- Maximum number of supported carriers within each band;
 - for contiguous spectrum operation

4.7 Specified frequency range and supported channel bandwidth

Unless otherwise stated, the test shall be performed with a lowest and the highest bandwidth supported by the BS. The manufacturer shall declare that the requirements are fulfilled for all other bandwidths supported by the BS which are not tested.

The manufacturer shall declare:

- which of the operating bands defined in subclause 5.5 are supported by the LMU.
- the frequency range within the above frequency band(s) supported by the LMU.
- the channel bandwidths supported by the LMU
- channel bandwidth combinations supported by the LMU for testing with UEs configured with CA.

For the single carrier testing many tests in this TS are performed with appropriate frequencies in the bottom, middle and top channels of the supported frequency range of the BS. These are denoted as RF channels B (bottom), M (middle) and T (top).

Unless otherwise stated, the test shall be performed with a single carrier at each of the RF channels B, M and T.

When a test is performed by a test laboratory, the EARFCNs to be used for RF channels B, M and T shall be specified by the laboratory. The laboratory may consult with operators, the manufacturer or other bodies.

When a test is performed by a manufacturer, the EARFCNs to be used for RF channels B, M and T may be specified by an operator.

4.7.1 RF bandwidth position for non-single carrier testing

Many tests in this TS are performed with the maximum RF bandwidth located at the bottom, middle and top of the supported frequency range in each operating band. These are denoted as B_{RFBW} (bottom), M_{RFBW} (middle) and T_{RFBW} (top).

Unless otherwise stated, the test shall be performed at B_{RFBW} , M_{RFBW} and T_{RFBW} defined as following:

- B_{RFBW} : maximum RF bandwidth located at the bottom of the supported frequency range in each operating band;
- M_{RFBW} : maximum RF bandwidth located in the middle of the supported frequency range in each operating band;
- T_{RFBW} : maximum RF bandwidth located at the top of the supported frequency range in each operating band.

When a test is performed by a test laboratory, the position of B_{RFBW} , M_{RFBW} and T_{RFBW} in the operating band shall be specified by the laboratory. The laboratory may consult with operators, the manufacturer or other bodies.

4.7.2 Aggregated channel bandwidth position for CA specific testing

Occupied bandwidth test in this TS is performed with the aggregated channel bandwidth and sub-block bandwidths located at the bottom, middle and top of the supported frequency range in the operating band. These are denoted as $B_{\text{BW Channel CA}}$ (bottom), $M_{\text{BW Channel CA}}$ (middle) and $T_{\text{BW Channel CA}}$ (top) for contiguous spectrum operation.

Unless otherwise stated, the test for contiguous spectrum operation shall be performed at $B_{\text{BW Channel CA}}$, $M_{\text{BW Channel CA}}$ and $T_{\text{BW Channel CA}}$ defined as following:

- $B_{\text{BW Channel CA}}$: aggregated channel bandwidth located at the bottom of the supported frequency range in each operating band;
- $M_{\text{BW Channel CA}}$: aggregated channel bandwidth located close in the middle of the supported frequency range in each operating band, with the center frequency of each component carrier aligned to the channel raster;
- $T_{\text{BW Channel CA}}$: aggregated channel bandwidth located at the top of the supported frequency range in each operating band.

When a test is performed by a test laboratory, the position of $B_{\text{BW Channel CA}}$, $M_{\text{BW Channel CA}}$ and $T_{\text{BW Channel CA}}$ for contiguous spectrum operation in the operating band shall be specified by the laboratory. The laboratory may consult with operators, the manufacturer or other bodies.

4.8 Format and interpretation of tests

Each test in the following clauses has a standard format:

X Title

All tests are applicable to all equipment within the scope of the present document, unless otherwise stated.

X.1 Definition and applicability

This subclause gives the general definition of the parameter under consideration and specifies whether the test is applicable to all equipment or only to a certain subset. Required manufacturer declarations may be included here.

X.2 Minimum Requirement

This subclause contains the reference to the subclause to the 3GPP reference (or core) specification which defines the Minimum Requirement.

X.3 Test Purpose

This subclause defines the purpose of the test.

X.4 Method of test

X.4.1 Initial conditions

This subclause defines the initial conditions for each test, including the test environment, the RF channels to be tested and the basic measurement set-up.

X.4.2 Procedure

This subclause describes the steps necessary to perform the test and provides further details of the test definition like point of access (e.g. test port), domain (e.g. frequency-span), range, weighting (e.g. bandwidth), and algorithms (e.g. averaging).

X.5 Test Requirement

This subclause defines the pass/fail criteria for the equipment under test. See subclause 4.1.2.5, Interpretation of measurement results.

5 Operating Bands and Channel Arrangement

5.1 General

The channel arrangements presented in this clause are based on the operating bands and channel bandwidths defined in the present release of specifications. LMUs can be declared to support the operating channels and channel bandwidths as defined in this specification. LMU can also be declared to support UL RTOA measurements for UEs configured with contiguous UL CA.

NOTE: Other operating bands and channel bandwidths may be considered in future releases.

5.2 Operating bands

E-UTRA is designed to operate in the operating bands defined in Table 5.2-1.

Table 5.2-1 E-UTRA operating bands

E-UTRA Operating Band	Uplink (UL) operating band BS receive UE transmit	Downlink (DL) operating band BS transmit UE receive	Duplex Mode
	F _{UL_low} – F _{UL_high}	F _{DL_low} – F _{DL_high}	
1	1920 MHz – 1980 MHz	2110 MHz – 2170 MHz	FDD
2	1850 MHz – 1910 MHz	1930 MHz – 1990 MHz	FDD
3	1710 MHz – 1785 MHz	1805 MHz – 1880 MHz	FDD
4	1710 MHz – 1755 MHz	2110 MHz – 2155 MHz	FDD
5	824 MHz – 849 MHz	869 MHz – 894MHz	FDD
6 ¹	830 MHz – 840 MHz	875 MHz – 885 MHz	FDD
7	2500 MHz – 2570 MHz	2620 MHz – 2690 MHz	FDD
8	880 MHz – 915 MHz	925 MHz – 960 MHz	FDD
9	1749.9 MHz – 1784.9 MHz	1844.9 MHz – 1879.9 MHz	FDD
10	1710 MHz – 1770 MHz	2110 MHz – 2170 MHz	FDD
11	1427.9 MHz – 1447.9 MHz	1475.9 MHz – 1495.9 MHz	FDD
12	699 MHz – 716 MHz	729 MHz – 746 MHz	FDD
13	777 MHz – 787 MHz	746 MHz – 756 MHz	FDD
14	788 MHz – 798 MHz	758 MHz – 768 MHz	FDD
15	Reserved	Reserved	FDD
16	Reserved	Reserved	FDD
17	704 MHz – 716 MHz	734 MHz – 746 MHz	FDD
18	815 MHz – 830 MHz	860 MHz – 875 MHz	FDD
19	830 MHz – 845 MHz	875 MHz – 890 MHz	FDD
20	832 MHz – 862 MHz	791 MHz – 821 MHz	FDD
21	1447.9 MHz – 1462.9 MHz	1495.9 MHz – 1510.9 MHz	FDD
22	3410 MHz – 3490 MHz	3510 MHz – 3590 MHz	FDD
23	2000 MHz – 2020 MHz	2180 MHz – 2200 MHz	FDD
24	1626.5 MHz – 1660.5 MHz	1525 MHz – 1559 MHz	FDD
25	1850 MHz – 1915 MHz	1930 MHz – 1995 MHz	FDD
26	814 MHz – 849 MHz	859 MHz – 894 MHz	FDD
27	807 MHz – 824 MHz	852 MHz – 869 MHz	FDD
28	703 MHz – 748 MHz	758 MHz – 803 MHz	FDD
29	N/A	717 MHz – 728 MHz	FDD
...			
33	1900 MHz – 1920 MHz	1900 MHz – 1920 MHz	TDD
34	2010 MHz – 2025 MHz	2010 MHz – 2025 MHz	TDD
35	1850 MHz – 1910 MHz	1850 MHz – 1910 MHz	TDD
36	1930 MHz – 1990 MHz	1930 MHz – 1990 MHz	TDD
37	1910 MHz – 1930 MHz	1910 MHz – 1930 MHz	TDD
38	2570 MHz – 2620 MHz	2570 MHz – 2620 MHz	TDD
39	1880 MHz – 1920 MHz	1880 MHz – 1920 MHz	TDD
40	2300 MHz – 2400 MHz	2300 MHz – 2400 MHz	TDD
41	2496 MHz – 2690 MHz	2496 MHz – 2690 MHz	TDD
42	3400 MHz – 3600 MHz	3400 MHz – 3600 MHz	TDD
43	3600 MHz – 3800 MHz	3600 MHz – 3800 MHz	TDD
44	703 MHz – 803 MHz	703 MHz – 803 MHz	TDD
Note 1:	Band 6 is not applicable.		
Note 2:	Restricted to E-UTRA operation when carrier aggregation is configured. The downlink operating band is paired with the uplink operating band (external) of the carrier aggregation configuration that is supporting the configured Pcell.		

E-UTRA is designed to operate for the carrier aggregation bands defined in Table 5.2-2.

Table 5.2-2. Intra-band contiguous carrier aggregation bands

CA Band	E-UTRA operating band

CA_1	1
CA_7	7
CA_38	38
CA_40	40
CA_41	41

5.3 Channel bandwidth

LMU requirements are for the channel bandwidths listed in Table 5.3-1.

Table 5.3-1: Transmission bandwidth configuration N_{RB} in E-UTRA channel bandwidths

Channel bandwidth $BW_{Channel}$ [MHz]	1.4	3	5	10	15	20
Transmission bandwidth configuration N_{RB}	6	15	25	50	75	100

Figure 5.3-1 shows the relation between the Channel bandwidth ($BW_{Channel}$) and the Transmission bandwidth configuration (N_{RB}). The channel edges are defined as the lowest and highest frequencies of the carrier separated by the channel bandwidth, i.e. at $F_C \pm BW_{Channel} / 2$.

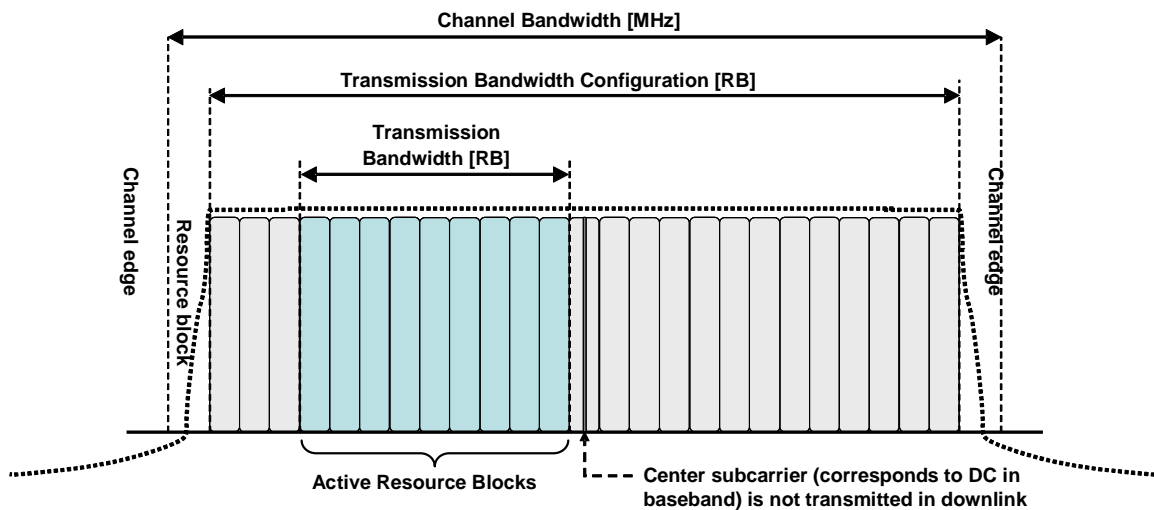

Figure 5.3-1: Definition of Channel Bandwidth and Transmission Bandwidth Configuration for one E-UTRA carrier.

Figure 5.3-2 illustrates the aggregated channel bandwidth for intra-band carrier aggregation.

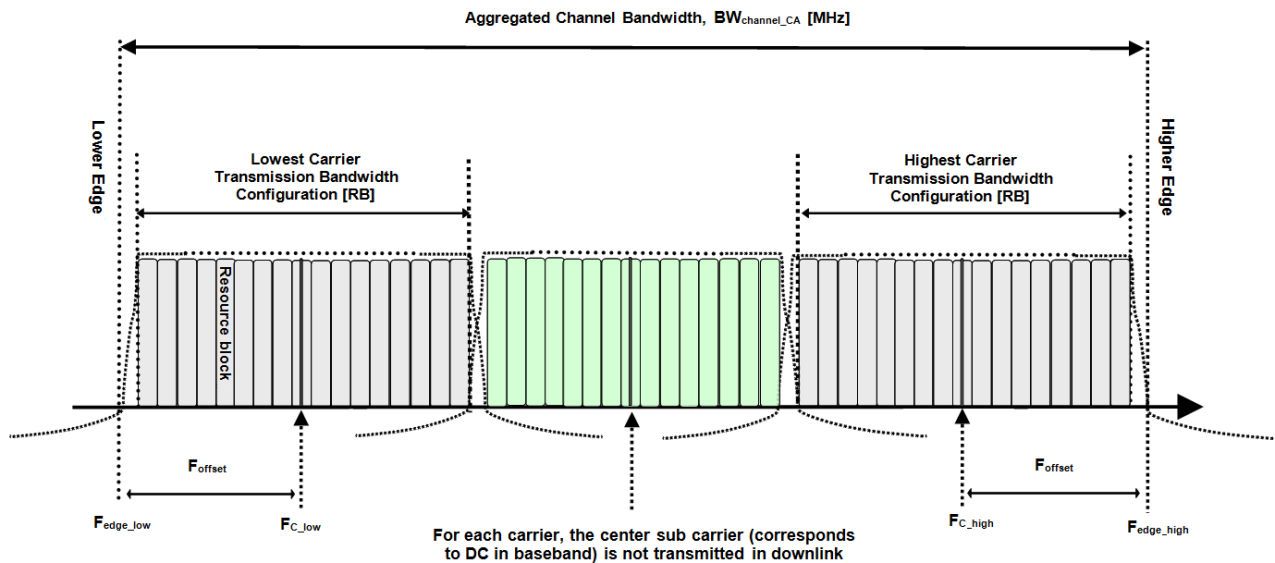

Figure 5.3-2: Definition of Aggregated Channel Bandwidth for intra-band carrier aggregation

The lower edge of the Aggregated Channel Bandwidth ($BW_{\text{Channel_CA}}$) is defined as $F_{\text{edge_low}} = F_{C_low} - F_{\text{offset}}$. The upper edge of the aggregated channel bandwidth is defined as $F_{\text{edge_high}} = F_{C_high} + F_{\text{offset}}$. The Aggregated Channel Bandwidth, $BW_{\text{Channel_CA}}$, is defined as follows:

$$BW_{\text{Channel_CA}} = F_{\text{edge_high}} - F_{\text{edge_low}} \text{ [MHz]}$$

5.4 Channel arrangement

5.4.1 Channel spacing

The spacing between carriers will depend on the deployment scenario, the size of the frequency block available and the channel bandwidths. The nominal channel spacing between two adjacent E-UTRA carriers is defined as following:

$$\text{Nominal Channel spacing} = (BW_{\text{Channel}(1)} + BW_{\text{Channel}(2)})/2$$

where $BW_{\text{Channel}(1)}$ and $BW_{\text{Channel}(2)}$ are the channel bandwidths of the two respective E-UTRA carriers. The channel spacing can be adjusted to optimize performance in a particular deployment scenario.

5.4.2 CA Channel spacing

For intra-band contiguously aggregated carriers the channel spacing between adjacent component carriers shall be multiple of 300 kHz.

The nominal channel spacing between two adjacent aggregated E-UTRA carriers is defined as follows:

$$\text{Nominal channel spacing} = \left\lceil \frac{BW_{\text{Channel}(1)} + BW_{\text{Channel}(2)} - 0.1 |BW_{\text{Channel}(1)} - BW_{\text{Channel}(2)}|}{0.6} \right\rceil 0.3$$

where $BW_{\text{Channel}(1)}$ and $BW_{\text{Channel}(2)}$ are the channel bandwidths of the two respective E-UTRA component carriers according to Table 5.4-1 with values in MHz. The channel spacing for intra-band contiguous carrier aggregation can be adjusted to any multiple of 300 kHz less than the nominal channel spacing to optimize performance in a particular deployment scenario.

5.4.3 Channel raster

The channel raster is 100 kHz for all bands, which means that the carrier centre frequency must be an integer multiple of 100 kHz.

5.4.4 Carrier frequency and EARFCN

The carrier frequency in the uplink and downlink is designated by the E-UTRA Absolute Radio Frequency Channel Number (EARFCN) in the range 0 - 65535. The relation between EARFCN and the carrier frequency in MHz for the downlink is given by the following equation, where F_{DL_low} and $N_{Offs-DL}$ are given in table 5.4.4-1 and N_{DL} is the downlink EARFCN.

$$F_{DL} = F_{DL_low} + 0.1(N_{DL} - N_{Offs-DL})$$

The relation between EARFCN and the carrier frequency in MHz for the uplink is given by the following equation where F_{UL_low} and $N_{Offs-UL}$ are given in table 5.4.4-1 and N_{UL} is the uplink EARFCN.

$$F_{UL} = F_{UL_low} + 0.1(N_{UL} - N_{Offs-UL})$$

Table 5.4.4-1: E-UTRA channel numbers

E-UTRA Operating Band	Downlink			Uplink		
	F _{DL_low} [MHz]	N _{Offs-DL}	Range of N _{DL}	F _{UL_low} [MHz]	N _{Offs-UL}	Range of N _{UL}
1	2110	0	0 – 599	1920	18000	18000 – 18599
2	1930	600	600 – 1199	1850	18600	18600 – 19199
3	1805	1200	1200 – 1949	1710	19200	19200 – 19949
4	2110	1950	1950 – 2399	1710	19950	19950 – 20399
5	869	2400	2400 – 2649	824	20400	20400 – 20649
6	875	2650	2650 – 2749	830	20650	20650 – 20749
7	2620	2750	2750 – 3449	2500	20750	20750 – 21449
8	925	3450	3450 – 3799	880	21450	21450 – 21799
9	1844.9	3800	3800 – 4149	1749.9	21800	21800 – 22149
10	2110	4150	4150 – 4749	1710	22150	22150 – 22749
11	1475.9	4750	4750 – 4949	1427.9	22750	22750 – 22949
12	729	5010	5010 – 5179	699	23010	23010 – 23179
13	746	5180	5180 – 5279	777	23180	23180 – 23279
14	758	5280	5280 – 5379	788	23280	23280 – 23379
...						
17	734	5730	5730 – 5849	704	23730	23730 – 23849
18	860	5850	5850 – 5999	815	23850	23850 – 23999
19	875	6000	6000 – 6149	830	24000	24000 – 24149
20	791	6150	6150 – 6449	832	24150	24150 – 24449
21	1495.9	6450	6450 – 6599	1447.9	24450	24450 – 24599
22	3510	6600	6600-7399	3410	24600	24600-25399
23	2180	7500	7500 – 7699	2000	25500	25500 – 25699
24	1525	7700	7700 – 8039	1626.5	25700	25700 – 26039
25	1930	8040	8040 – 8689	1850	26040	26040 – 26689
26	859	8690	8690 – 9039	814	26690	26690 - 27039
27	852	9040	9040 – 9209	807	27040	27040 – 27209
28	758	9210	9210 – 9659	703	27210	27210 – 27659
29 ²	717	9660	9660 – 9769	N/A		
...						
33	1900	36000	36000 – 36199	1900	36000	36000 – 36199
34	2010	36200	36200 – 36349	2010	36200	36200 – 36349
35	1850	36350	36350 – 36949	1850	36350	36350 – 36949
36	1930	36950	36950 – 37549	1930	36950	36950 – 37549
37	1910	37550	37550 – 37749	1910	37550	37550 – 37749
38	2570	37750	37750 – 38249	2570	37750	37750 – 38249
39	1880	38250	38250 – 38649	1880	38250	38250 – 38649
40	2300	38650	38650 – 39649	2300	38650	38650 – 39649
41	2496	39650	39650 – 41589	2496	39650	39650 – 41589
42	3400	41590	41590 – 43589	3400	41590	41590 – 43589
43	3600	43590	43590 – 45589	3600	43590	43590 – 45589
44	703	45590	45590 – 46589	703	45590	45590 – 46589

NOTE 1: The channel numbers that designate carrier frequencies so close to the operating band edges that the carrier extends beyond the operating band edge shall not be used. This implies that the first 7, 15, 25, 50, 75 and 100 channel numbers at the lower operating band edge and the last 6, 14, 24, 49, 74 and 99 channel numbers at the upper operating band edge shall not be used for channel bandwidths of 1.4, 3, 5, 10, 15 and 20 MHz respectively.

NOTE 2: Restricted to E-UTRA operation when carrier aggregation is configured.

5.5 Requirements for contiguous spectrum

A spectrum allocation where the LMU operates is contiguous. Unless otherwise stated, the tests in the present specification apply for LMUs configured for contiguous spectrum operation.

6 Conformance Tests for LMU RF Requirements

6.1 General

The performance metrics used in RF requirements are detection probability and false alarm. The requirements for the detection probability and false alarm are specified in TS 36.111, subclause 5.1.1.

False alarm is measured according to an SRS configuration provided to LMU by the E-SMLC.

6.2 Reference sensitivity level

6.2.1 Definition and applicability

The reference sensitivity power level P_{REFSENS} is the minimum mean power received at the antenna connector at which a detection probability requirement and a false alarm requirement shall be met for a specified reference measurement channel.

Test ports and the RF requirements applicability is as specified in [2], Table 5.1-1.

6.2.2 Minimum requirement

The minimum requirement is in TS 36.111 [2] subclause 5.2.1.

6.2.3 Test Purpose

To verify that at the LMU reference sensitivity level the probability of detection requirement and a false alarm requirement shall be met for a specified reference measurement channel.

6.2.4 Method of testing

6.2.4.1 Initial conditions

Test environment: normal; see subclause D.X

RF channels to be tested: B, M and T; see subclause 4.7.

The following additional tests shall be performed:

On each of B, M and T, the test shall be performed under extreme power supply as defined in subclause D.X

NOTE: Tests under extreme power supply also test extreme temperature.

Connect the test equipment as shown in Annex G.1.1.

6.2.4.2 Procedure

- 1) Set the test signal mean power as specified in table 6.2.5-1.
- 2) Measure the detection probability and false alarm rate according to Annex E.

6.2.5 Test requirement

The LMU shall receive the reference measurement channel while meeting the detection probability and false alarm rate requirements specified in TS 36.111, subclause 5.1.1. The reference measurement channel is described in Table 6.2.5-1 with parameters specified in Table A.1-1.

Table 6.2.5-1: LMU reference sensitivity levels

E-UTRA channel bandwidth [MHz]	Reference measurement channel	Reference sensitivity power level, PREFSENS ^{Note} [dBm]	
		$f \leq 3.0\text{GHz}$	$3.0\text{GHz} < f \leq 4.2\text{GHz}$
1.4	Annex A	-130.1	-129.8
3	Annex A	-130.1	-129.8
5	Annex A	-130.1	-129.8
10	Annex A	-130.1	-129.8
15	Annex A	-130.1	-129.8
20	Annex A	-130.1	-129.8
NOTE: The reference sensitivity levels are adjusted from the requirements in TS 36.111 clause 5.2.1 according to the measurement uncertainty described in TBD.			

6.3 Dynamic range

6.3.1 Definition and applicability

The dynamic range is specified as a measure of the capability of the receiver to receive a wanted signal in the presence of an interfering signal inside the received channel bandwidth. In this condition a detection probability requirement and a false alarm requirements as specified in 36.111, Section X, shall be met for a specified reference measurement channel.

The interfering signal for the dynamic range requirement is an AWGN signal.

False alarm is measured according to an SRS configuration provided to LMU by E-SMLC.

Test ports and the RF requirements applicability is as specified in [2], Table 5.1-1.

6.3.2 Minimum Requirement

The minimum requirement is in TS 36.111 [2] subclause 5.3.1.

6.3.3 Test purpose

To verify that at the LMU dynamic range the probability of detection requirement and a false alarm requirement shall be met for a specified reference measurement channel.

6.3.4 Method of testing

6.3.4.1 Initial conditions

Test environment: normal; see subclause D.2

RF channels to be tested: B, M and T; see subclause 4.7.

The following additional tests shall be performed:

On each of B, M and T, the test shall be performed under extreme power supply as defined in subclause D.5

NOTE: Tests under extreme power supply also test extreme temperature.

Connect the test equipment as shown in Annex G.1.2

6.3.4.2 Procedure

1) Set the test signal mean power as specified in table 6.3.5-1.

- 2) Measure the detection probability and false alarm rate according to Annex E.

6.3.5 Test Requirements

The LMU shall receive the reference measurement channel while meeting the detection probability and the false alarm rate requirements specified in 36.111, subclause 5.1.1. The reference measurement channel is specified in Table A.1-1.

Table 6.3.5-1: LMU dynamic range

E-UTRA channel bandwidth [MHz]	Reference measurement channel	Wanted signal mean power [dBm]	Interfering signal mean power [dBm] / BW_{Config}	Type of interfering signal
1.4	Annex A	-108.2	-88.7	AWGN
3	Annex A	-104.3	-84.7	AWGN
5	Annex A	-102.1	-82.5	AWGN
10	Annex A	-99.1	-79.5	AWGN
15	Annex A	-97.3	-77.7	AWGN
20	Annex A	-96.0	-76.4	AWGN
NOTE: The wanted signal power levels are adjusted from the requirements in TS 36.111 clause 5.3.1 according to the measurement uncertainty described in clause 4.1.2.1.				

6.4 In-channel selectivity

6.4.1 Definition and applicability

In-channel selectivity (ICS) is a measure of the receiver ability to receive a wanted signal at its assigned resource block locations in the presence of an interfering signal received at a larger power spectral density. In this condition a detection probability requirement and a false alarm requirements shall be met for a specified reference measurement channel.

The interfering signal shall be an E-UTRA signal as specified in Annex C and shall be time aligned with the wanted signal.

Test ports and the RF requirements applicability is as specified in 3GPP TS 36.111 [2], Table 5.1-1.

6.4.2 Minimum Requirement

The minimum requirement is in 3GPP TS 36.111 [2] subclause 5.4.1.

6.4.3 Test purpose

The purpose of this test is to verify the LMU receiver ability to suppress the IQ leakage the probability of so the probability of detection requirement and a false alarm requirement shall be met for a specified reference measurement channel.

6.4.4 Method of testing

6.4.4.1 Initial conditions

Test environment: normal; see subclause D.2

RF channels to be tested: B, M and T; see subclause 4.7.

The following additional tests shall be performed:

On each of B, M and T, the test shall be performed under extreme power supply as defined in subclause D.5

NOTE: Tests under extreme power supply also test extreme temperature.

Connect the test equipment as shown in Annex G.1.3

6.4.4.2 Procedure

- 1) Set the test signal mean power as specified in table 6.4.5-1.
- 2) Set the interfering signal mean power as specified in table 6.4.5-1.
- 3) Measure the detection probability and false alarm rate according to Annex E.

False alarm is measured according to an SRS configuration provided to LMU by E-SMLC.

6.4.5 Test Requirements

The LMU shall receive the reference measurement channel while meeting the detection probability and the false alarm rate requirements specified in 36.111, subclause 5.1.1. The reference measurement channel is described in Table 6.4.5-1 with parameters specified in Table A.1-1.

Table 6.4.5-1 LMU in-channel selectivity

E-UTRA channel bandwidth (MHz)	Reference measurement channel	Wanted signal mean power [dBm]		Interfering signal mean power [dBm]	Type of interfering signal
		$f \leq 3.0\text{GHz}$	$3.0\text{GHz} < f \leq 4.2\text{GHz}$		
1.4	Annex A	-126.4	-126.0	-91	1.4 MHz E-UTRA PUCCH signal, 2 RBs (see note)
3	Annex A	-126.4	-126.0	-85	3 MHz E-UTRA PUSCH signal, 4 RBs (see note)
5	Annex A	-126.4	-126.0	-85	5 MHz E-UTRA PUSCH signal, 4 RBs (see note)
10	Annex A	-126.4	-126.0	-85	10 MHz E-UTRA PUSCH signal, 4 RBs (see note)
15	Annex A	-126.4	-126.0	-85	15 MHz E-UTRA PUSCH signal, 4 RBs (see note)
20	Annex A	-126.4	-126.0	-85	20 MHz E-UTRA PUSCH signal, 4 RBs (see note)
NOTE: NOTE: The wanted signal power levels are adjusted from the requirements in TS 36.111 clause 5.2.4 according to the measurement uncertainty described in clause 4.1.2.					

6.5 Adjacent channel selectivity (ACS) and narrow-band blocking

6.5.1 Definition and applicability

Adjacent channel selectivity (ACS) is a measure of the receiver ability to receive a wanted signal at its assigned channel frequency in the presence of an adjacent channel signal with a specified centre frequency offset of the interfering signal to the band edge of a victim system. In this condition a detection probability requirement and a false alarm requirements shall be met for a specified reference measurement channel.

The interfering signal shall be an E-UTRA signal as specified in Annex C.

Test ports and the RF requirements applicability is as specified in [2], Table 5.1-1.

6.5.2 Minimum Requirement

The minimum requirement is in TS 36.111 [2] subclause 5.5.1.

6.5.3 Test purpose

The test purpose is to verify the ability of the LMU receiver filter to suppress interfering signals in the channels adjacent to the wanted channel so the probability of detection requirement and a false alarm requirement shall be met for a specified reference measurement channel.

6.5.4 Method of test

6.5.4.1 Initial conditions

Test environment: normal; see subclause D.2

RF channels to be tested: B, M and T; see subclause 4.7.

The following additional tests shall be performed:

On each of B, M and T, the test shall be performed under extreme power supply as defined in subclause D.5

NOTE: Tests under extreme power supply also test extreme temperature.

Connect the test equipment as shown in Annex G.1.4

6.5.4.2 Procedure

- 1) Set the test signal mean power as specified in table 6.5.5-3.
- 2) Set the interfering mean signal power and center frequency as specified in table 6.5.5-3.
- 3) Measure the detection probability and false alarm rate according to Annex E.

False alarm is measured according to an SRS configuration provided to LMU by E-SMLC.

6.5.4.3 Procedure for narrow-band blocking

- 1) Set the test signal mean power as specified in table 6.5.5-1.
- 2) Set the interfering mean signal power as specified in table 6.5.5-1.
- 3) Set the interfering signal center frequency as specified in table 6.5.5-2.
- 4) Measure the detection probability and false alarm rate according to Annex E.

False alarm is measured according to an SRS configuration provided to LMU by E-SMLC.

6.5.5 Test Requirements

The LMU shall receive the reference measurement channel while meeting the detection probability and the false alarm rate requirements specified in 36.111, subclause 5.1.1. The reference measurement channel is specified in Table A.1-1.

Table 6.5.5-1: Narrowband blocking requirement

Wanted signal mean power [dBm]	Interfering signal mean power [dBm]	Type of interfering signal
$P_{\text{REFSENS}} + 13 \text{ dB}$	-49	See Table 6.5-2

Table 6.5.5-2: Interfering signal for Narrowband blocking requirement

E-UTRA channel BW of the lowest (highest) carrier received [MHz]	Interfering RB centre frequency offset to the lower (higher) edge [kHz]	Type of interfering signal
1.4	$\pm(252.5+m*180)$, m=0, 1, 2, 3, 4, 5	1.4 MHz E-UTRA signal, 1 RB (see note)
3	$\pm(247.5+m*180)$, m=0, 1, 2, 3, 4, 7, 10, 13	3 MHz E-UTRA signal, 1 RB (see note)
5	$\pm(342.5+m*180)$, m=0, 1, 2, 3, 4, 9, 14, 19, 24	5 MHz E-UTRA signal, 1 RB (see note)
10	$\pm(347.5+m*180)$, m=0, 1, 2, 3, 4, 9, 14, 19, 24	5 MHz E-UTRA signal, 1 RB (see note)
15	$\pm(352.5+m*180)$, m=0, 1, 2, 3, 4, 9, 14, 19, 24	5 MHz E-UTRA signal, 1 RB (see note)
20	$\pm(342.5+m*180)$, m=0, 1, 2, 3, 4, 9, 14, 19, 24	5 MHz E-UTRA signal, 1 RB (see note)

NOTE: Interfering signal consisting of one resource block is positioned at the stated offset; the channel bandwidth of the interfering signal is located adjacently to the lower (upper) edge.

Table 6.5.5-3: LMU Adjacent channel selectivity

E-UTRA channel bandwidth of the lowest (highest) carrier received [MHz]	Wanted signal mean power [dBm]	Interfering signal mean power [dBm]	Interfering signal centre frequency offset from the lower (higher) edge [MHz]	Type of interfering signal
1.4	$P_{\text{REFSENS}} + 13$ dB	-52	± 0.7025	1.4 MHz E-UTRA signal 4 RBs
3	$P_{\text{REFSENS}} + 13$ dB	-52	± 1.5075	3 MHz E-UTRA signal 4 RBs
5	$P_{\text{REFSENS}} + 13$ dB	-52	± 2.5025	5 MHz E-UTRA signal 4 RBs
10	$P_{\text{REFSENS}} + 13$ dB	-52	± 2.5075	5 MHz E-UTRA signal 4 RBs
15	$P_{\text{REFSENS}} + 13$ dB	-52	± 2.5125	5 MHz E-UTRA signal 4 RBs
20	$P_{\text{REFSENS}} + 13$ dB	-52	± 2.5025	5 MHz E-UTRA signal 4 RBs

6.6 Blocking

6.6.1 Definition and applicability

The blocking characteristics is a measure of the receiver ability to receive a wanted signal at its assigned channel in the presence of an unwanted interferer, which are either a 1.4 MHz, 3 MHz or 5 MHz E-UTRA signal for in-band blocking or a CW signal for out-of-band blocking. In this condition a detection probability requirement and a false alarm requirements shall be met for a specified reference measurement channel.

The interfering signal shall be an E-UTRA signal as specified in Annex C.

Test ports and the RF requirements applicability is as specified in [2], Table 5.1-1.

6.6.2 Minimum Requirements

The minimum requirement is in TS 36.111 [2] subclause 5.6.1.

6.6.3 Test purpose

The test stresses the ability of the LMU receiver to withstand high-level interference from unwanted signals at specified frequency offsets without undue degradation of its sensitivity so the probability of detection requirement and a false alarm requirement shall be met for a specified reference measurement channel.

6.6.4 Method of test

6.6.4.1 Initial conditions

Test environment: normal; see subclause D.2

RF channels to be tested: B, M and T; see subclause 4.7.

The following additional tests shall be performed:

On each of B, M and T, the test shall be performed under extreme power supply as defined in subclause D.5

NOTE: Tests under extreme power supply also test extreme temperature.

Connect the test equipment as shown in Annex G.1.5

6.6.4.2 Procedure

- 1) Set the test signal mean power as specified in table 6.6.5-1.
- 2) Set the interfering signal mean power and center frequency as specified in table 6.6.5-1.
- 3) Measure the detection probability and false alarm rate according to Annex E.

False alarm is measured according to an SRS configuration provided to LMU by E-SMLC.

6.6.5 Test Requirements

The LMU shall receive the reference measurement channel while meeting the detection probability and the false alarm rate requirements specified in 36.111, subclause 5.1.1. The reference measurement channel is specified in Table A.1-1.

Table 6.6.5-1: LMU Blocking performance requirement

Operating Band	Centre Frequency of Interfering Signal [MHz]	Interfering Signal mean power [dBm]	Wanted Signal mean power [dBm]	Interfering signal centre frequency minimum frequency offset from the lower (higher) edge [MHz]	Type of Interfering Signal
1-7, 9-11, 13, 14, 18,19, 21-23, 24, 27, 33-43, 44	(F _{UL_low} -20) to (F _{UL_high} +20)	-43	P _{REFSENS} +13 dB	See table 6.6.5-2	See table 5.6.1.1-2
	1 to (F _{UL_low} -20) (F _{UL_high} +20) to 12750	-15	P _{REFSENS} +13 dB	—	CW carrier
8, 26, 28	(F _{UL_low} -20) to (F _{UL_high} +10)	-43	P _{REFSENS} +13 dB	See table 6.6.5-2	See table 5.6.1.1-2
	1 to (F _{UL_low} -20) (F _{UL_high} +10) to 12750	-15	P _{REFSENS} +13 dB	—	CW carrier
12	(F _{UL_low} -20) to (F _{UL_high} +13)	-43	P _{REFSENS} +13 dB	See table 6.6.5-2	See table 5.6.1.1-2
	1 to (F _{UL_low} -20) (F _{UL_high} +13) to 12750	-15	P _{REFSENS} +13 dB	—	CW carrier
17	(F _{UL_low} -20) to (F _{UL_high} +18)	-43	P _{REFSENS} +13 dB	See table 6.6.5-2	See table 5.6.1.1-2
	1 to (F _{UL_low} -20) (F _{UL_high} +18) to 12750	-15	P _{REFSENS} +13 dB	—	CW carrier
20	(F _{UL_low} -11) to (F _{UL_high} +20)	-43	P _{REFSENS} +13 dB	See table 6.6.5-2	See table 5.6.1.1-2
	1 to (F _{UL_low} -11) (F _{UL_high} +20) to 12750	-15	P _{REFSENS} +13 dB	—	CW carrier
25	(F _{UL_low} -20) to (F _{UL_high} +15)	-43	P _{REFSENS} +13 dB	See table 6.6.5-2	See table 5.6.1.1-2
	1 to (F _{UL_low} -20) (F _{UL_high} +15) to 12750	-15	P _{REFSENS} +13 dB	—	CW carrier

NOTE: Table 6.6.5-1 assumes that two operating bands, where the downlink operating band (see Table 5.5-1 of TS 36.104) of one band would be within the in-band blocking region of the other band, are not deployed in the same geographical area.

Table 6.6.5-2: Interfering signals for blocking performance requirement

E-UTRA channel BW of the lowest (highest) carrier received [MHz]	Interfering signal centre frequency minimum offset to the lower (higher) edge [MHz]	Type of interfering signal
1.4	±2.1	1.4 MHz E-UTRA signal 4 RBs
3	±4.5	3 MHz E-UTRA signal 4 RBs
5	±7.5	5 MHz E-UTRA signal 4 RBs
10	±7.5	5 MHz E-UTRA signal 4 RBs
15	±7.5	5 MHz E-UTRA signal 4 RBs
20	±7.5	5 MHz E-UTRA signal 4 RBs

6.7 Receiver spurious emissions

6.7.1 Definition and applicability

The spurious emissions power is the power of emissions generated or amplified in a receiver that appear at the LMU receiver antenna connector. The requirement specified in this clause, is to reduce the impact on a co-sited BS, a different BS, or a different LMU.

Test ports and the RF requirements applicability is as specified in [2], Table 5.1-1.

6.7.2 Minimum Requirements

The minimum requirement is in TS 36.111 [2] subclause 5.7.1.

6.7.3 Test purpose

The test purpose is to verify the ability of the LMU to limit the interference caused by receiver spurious emissions to other systems.

6.7.4 Method of test

6.7.4.1 Initial conditions

Test environment: normal; see subclause D.2.

RF channels to be tested: M, see subclause 4.7.

RF bandwidth position to be tested: M_{RFBW} , see subclause 4.7.1.

- 1) Connect a measurement receiver to the LMU antenna connector as shown in Annex G1.6.
- 2) Measure the spurious emissions power at a relevant receiver, according to test ports and the RF requirements applicability specified in [2], Table 5.1-1.

6.7.4.2 Procedure

- 1) Measure the spurious emissions over each frequency range described in subclause 6.7.5, for each receive antenna.

6.7.5 Test requirements

The power of any spurious emission shall not exceed the levels in Table 6.7.5-1.

Table 6.7.5-1: General spurious emission test requirement

Frequency range	Maximum level	Measurement Bandwidth	Note
30MHz - 1 GHz	-57 dBm	100 kHz	
1 GHz - 12.75 GHz	-47 dBm	1 MHz	
12.75 GHz - 5 th harmonic of the upper frequency edge of the UL operating band in GHz	-47 dBm	1 MHz	Applies only for Bands 22, 42 and 43.
NOTE: The frequency range between $2.5 * BW_{\text{Channel}}$ below the first carrier frequency and $2.5 * BW_{\text{Channel}}$ above the last carrier frequency transmitted by the BS, where BW_{Channel} is the channel bandwidth according to Table 5.6-1, may be excluded from the requirement. However, frequencies that are more than 10 MHz below the lowest frequency of the BS downlink operating band or more than 10 MHz above the highest frequency of the BS downlink operating band (see Table 5.5-1) shall not be excluded from the requirement.			

NOTE: If the above Test Requirement differs from the Minimum Requirement then the Test Tolerance applied for this test is non-zero. The relationship between Minimum Requirements and Test Requirements is defined in subclause 4.1 and the explanation of how the Minimum Requirement has been relaxed by the Test Tolerance is given in Annex G.

6.8 Receiver intermodulation

6.8.1 Definition and applicability

Third and higher order mixing of the two interfering RF signals can produce an interfering signal in the band of the desired channel. Intermodulation response rejection is a measure of the capability of the receiver to receive a wanted signal on its assigned channel frequency in the presence of two interfering signals which have a specific frequency relationship to the wanted signal. In this condition a detection probability requirement and a false alarm requirements shall be met for a specified reference measurement channel.

Interfering signals shall be a continuous wave signal and an E-UTRA signal as specified in Annex C.

Test ports and the RF requirements applicability is as specified in [2], Table 5.1-1.

6.8.2 Minimum Requirement

The minimum requirement is in TS 36.111[2] subclause 5.8.1.

6.8.3 Test purpose

The test purpose is to verify the ability of the LMU receiver to inhibit the generation of intermodulation products in its non-linear elements caused by the presence of two high-level interfering signals at frequencies with a specific relationship to the frequency of the wanted signal so the probability of detection requirement and a false alarm requirement shall be met for a specified reference measurement channel.

6.8.4 Method of test

6.8.4.1 Initial conditions

Test environment: normal; see subclause D.2.

RF channels to be tested: B, M and T; see subclause 4.7.

RF bandwidth position to be tested: B_{RFBW} and T_{RFBW} , see subclause 4.7.1.

- 1) Set-up the measurement system as shown in Annex G.1.7.

6.8.4.2 Procedures

- 1) Set the test wanted signal mean power as specified in table 6.8.5-1.
- 2) Set the interfering signal mean power as specified in table 6.8.5-1.
- 3) Set the interfering signals center frequencies as specified in table 6.8.5-2.
- 4) Measure the detection probability and false alarm rate according to Annex E.

False alarm is measured according to an SRS configuration provided to LMU by E-SMLC

6.8.5 Test requirements

The LMU shall receive the reference measurement channel while meeting the detection probability and the false alarm rate requirements specified in 36.111, subclause 5.1.1. The reference measurement channel is specified in Table A.1-1.

Table 6.8.5-1: Intermodulation performance requirement

Wanted signal mean power [dBm]	Interfering signal mean power [dBm]	Type of interfering signal
$P_{\text{REFSENS}} + 13\text{dB}$	-52	See Table 5.8.1-2

Table 6.8.5-2: Interfering signal for Intermodulation performance requirement

E-UTRA channel bandwidth of the lowest (highest) carrier received [MHz]	Interfering signal centre frequency offset from the lower (higher) edge [MHz]	Type of interfering signal
1.4	± 2.1	CW
	± 4.9	1.4 MHz E-UTRA signal, 4 RBs
3	± 4.5	CW
	± 10.5	3 MHz E-UTRA signal, 12 RBs
5	± 7.5	CW
	± 17.5	5 MHz E-UTRA signal, 20 RBs
10	± 7.375	CW
	± 17.5	5 MHz E-UTRA signal, 20 RBs
15	± 7.25	CW
	± 17.5	5 MHz E-UTRA signal, 20 RBs
20	± 7.125	CW
	± 17.5	5 MHz E-UTRA signal, 20 RBs

7 Conformance Tests for UL RTOA Measurement Time Requirements

7.1 General

The purpose of tests specified in Section 7 is to verify the LMU requirements in Section 6 of TS 36.111.

7.2 Requirements for FDD without DRX

7.2.1 Definition and applicability

This test is to verify LMU requirements in Section 6.2.1 of TS 36.111 and applies for LMU Class 1, Class 2, and Class 3.

The test is configured for 16 parallel measurements on the same carrier, i.e., $n=16$ and $N=16$ in the requirement specified in Section 6.2.1 of TS 36.111.

The RTOA measurement time is the time interval between when the LMU receives a SLmAP MEASUREMENT REQUEST and outputs a SLmAP MEASUREMENT RESPONSE.

7.2.2 Minimum requirement

The minimum requirement is in TS 36.111 [2] subclause 6.2.1.

7.2.3 Test Purpose

To verify that at the LMU can meet the UL RTOA measurement requirements for the UL RTOA measurements performed in parallel for multiple target UEs transmitting in FDD mode and not configured for DRX.

7.2.4 Method of testing

7.2.4.1 Initial conditions

Test environment: normal; see subclause D.2

RF channels to be tested: M; see subclause 4.7.

The following additional tests shall be performed:

On channel M, the test shall be performed under extreme power supply as defined in subclause D.3

NOTE: Tests under extreme power supply also test extreme temperature.

Connect the test equipment as shown in Annex G.2.1.

7.2.4.2 Procedure

1) Set the test signal input SNR as specified in table 7.2.5-1.

2) Receiver measurements during the time $T_{\text{RTOA,E-UTRAN FDD, nonDRX}}$ ms calculated for $n=16$ and $N=16$.

7.2.5 Test requirement

The LMU shall be able to perform and report 16 UL RTOA measurements for 16 UEs at the 90th percentile within $T_{\text{RTOA,E-UTRAN FDD, nonDRX}}$ ms for $n=16$ and $N=16$. The 16 parallel reference measurement channels are defined in Annex A, Tables A-5, A-6, A-7, A-8 and A-9.

7.3 Requirements for TDD without DRX

7.3.1 Definition and applicability

This test is to verify LMU requirements in Section 6.2.2 of TS 36.111 and applies for LMU Class 1, Class 2, and Class 3.

The test is configured for 16 parallel measurements on the same carrier, i.e., $n=16$ and $N=16$ in the requirement specified in Section 6.2.2 of TS 36.111.

The RTOA measurement time is the time interval between when the LMU receives a SLMAP MEASUREMENT REQUEST and outputs a SLMAP MEASUREMENT RESPONSE.

7.3.2 Minimum requirement

The minimum requirement is in TS 36.111 [2] subclause 6.2.2.

7.3.3 Test Purpose

To verify that at the LMU can meet the UL RTOA measurement requirements for the UL RTOA measurements performed in parallel for multiple target UEs transmitting in TDD mode and not configured for DRX.

7.3.4 Method of testing

7.3.4.1 Initial conditions

Test environment: normal; see subclause D.2

RF channels to be tested: M; see subclause 4.7.

The following additional tests shall be performed:

On channel M, the test shall be performed under extreme power supply as defined in subclause D.3

NOTE: Tests under extreme power supply also test extreme temperature.

Connect the test equipment as shown in Annex G.2.2.

7.3.4.2 Procedure

- 1) Set the test signal input SNR as specified in table 7.3.5-1.
- 2) Receiver measurements during the time $T_{\text{RTOA,E-UTRAN TDD, nonDRX}}$ ms calculated for $n=16$ and $N=16$.

7.3.5 Test requirement

The LMU shall be able to perform and report 16 UL RTOA measurements for 16 UEs at the 90th percentile within $T_{\text{RTOA,E-UTRAN TDD, nonDRX}}$ ms for $n=16$ and $N=16$. The 16 parallel reference measurement channels are defined in Annex A, Tables A-5, A-6, A-7, A-8 and A-9.

7.4 UL RTOA Measurements upon Receiving SRS Configuration Update

7.4.1 Definition and applicability

The RTOA measurement time is the time interval between when the LMU receives a SLmAP MEASUREMENT REQUEST and outputs a SLmAP MEASUREMENT RESPONSE.

7.4.2 Minimum requirement

The minimum requirement is in TS 36.111 [2] subclause 6.2.3.

7.4.3 Test Purpose

To verify that the LMU can perform parallel UL RTOA measurements of multiple target UEs within the specified measurement time when the LMU receives a SRS configuration update for the target UEs. The UEs are not configured with DRX.

7.4.4 Method of testing

7.4.4.1 Initial conditions

Test environment: normal; see subclause D.2

RF channels to be tested: M; see subclause 4.7.

The following additional tests shall be performed:

On channel M, the test shall be performed under extreme power supply as defined in subclause D.3

NOTE: Tests under extreme power supply also test extreme temperature.

Connect the test equipment as shown in Annex G.2.1.

7.4.4.2 Procedure

- 1) Set the test signal input SNR as specified in table 7.4.5-1.
- 2) Update the SRS configuration for each target UE during the UL RTOA measurement.
- 3) Receive the UL RTOA measurements in parallel during $T_{\text{RTOA,E-UTRAN FDD, nonDRX}}$.

7.4.5 Test requirement

The LMU shall be able to perform and report UL RTOA measurements for 16 UEs at the 90th percentile, based on their SRS transmissions, within $T_{\text{RTOA, E-UTRAN FDD, nonDRX}}$ ms. The 16 parallel reference measurement channels are defined in Annex A, Tables TBD and the updated SRS configurations are defined in Tables TBD.

8 Conformance Tests for UL RTOA Measurement Accuracy Requirements

8.1 General

The purpose of tests specified in Section 8 is to verify the LMU requirements in Section 7 of TS 36.111.

8.2 UL RTOA measurement accuracy for a UE not configured with CA

8.2.1 Definition and applicability

This test is to verify LMU requirements in Section 7.2.1 of TS 36.111 and applies for LMU Class 1, Class 2, and Class 3.

The performance requirement of UL RTOA is determined by a minimum required accuracy for a given SNR, SRS bandwidth, and measurement period. The required accuracy is expressed as a multiple of T_s .

8.2.2 Minimum requirement

The minimum requirement is in TS 36.111 [2] subclause 7.2.1.

8.2.3 Test Purpose

To verify that the LMU can meet UL RTOA measurement accuracy requirements in different channel conditions for a target UE transmitting SRS and not configured with CA, provided that the SRS are configured over at least a certain bandwidth and measured over a certain time period according to Table 8.2.5-1.

8.2.4 Method of testing

8.2.4.1 Initial conditions

Test environment: normal; see subclause D.2

RF channels to be tested: M; see subclause 4.7.

The following additional tests shall be performed:

On channel M, the test shall be performed under extreme power supply as defined in subclause D.3

NOTE: Tests under extreme power supply also test extreme temperature.

Connect the test equipment as shown in Annex G.3.1.

8.2.4.2 Procedure

- 1) Set the test signal input \hat{E}_s/I_{ot} according to Table 8.2.5-1. The minimum I_o is -125.1 dBm/15 kHz and the maximum I_o is -50 dBm/BWchannel.

2) Measure the UL RTOA according to Annex E.

8.2.5 Test requirement

The LMU shall measure the UL RTOA with the accuracy at the 90th percentile as defined in table 8.2.5-1. The reference measurement channel is specified in Annex A Tables A-3 and A-4.

Table 8.2.5-1: LMU UL RTOA measurement accuracy without CA

SRS Bandwidth (RBs)	Input \hat{E}_s /lot (dB)	AWGN		EPA5		ETU30	
		Minimum number of SRS transmissions	90% RTOA (Ts)	Minimum number of SRS transmissions	90% RTOA (Ts)	Minimum number of SRS transmissions	90% RTOA (Ts)
4	-16.6	233	10	250	10	421	16
8	-16.6	71	8	77	10	127	14
12	-16.6	37	8	42	8	90	14
16	-16.6	24	8	29	10	63	12
20	-16.6	17	8	22	8	52	12
24	-16.6	14	8	18	8	44	12
32	-16.6	9	8	13	8	35	12
36	-16.6	8	6	12	8	32	12
40	-16.6	7	6	10	8	29	12
48	-16.6	5	6	9	8	25	12
60	-16.6	5	6	7	8	20	14
64	-16.6	4	6	7	8	18	14
72	-16.6	4	6	6	8	17	14
80	-16.6	3	6	6	8	15	14
96	-16.6	3	6	5	8	13	14

8.3 UL RTOA measurement accuracy for a UE configured with CA

8.3.1 Definition and applicability

This test is to verify LMU requirements in Section 7.2.2 of TS 36.111 and applies for LMU Class 1, Class 2, and Class 3.

The performance requirement of UL RTOA is determined by a minimum required accuracy for a given SNR, SRS bandwidth, and measurement period. The required accuracy is expressed as a multiple of Ts.

UL CA configuration is FFS.

8.3.2 Minimum requirement

The minimum requirement is in TS 36.111 [2] subclause 7.2.2.

8.3.3 Test Purpose

To verify that the LMU can meet UL RTOA measurement accuracy requirements in different channel conditions for a target UE transmitting SRS and configured with UL CA, provided that the SRS are configured over at least a certain bandwidth and measured over a certain time period according to Table 8.3.5-1.

8.3.4 Method of testing

8.3.4.1 Initial conditions

Test environment: normal; see subclause D.2

RF channels to be tested: M; see subclause 4.7.

The following additional tests shall be performed:

On channel M, the test shall be performed under extreme power supply as defined in subclause D.3

NOTE: Tests under extreme power supply also test extreme temperature.

Connect the test equipment as shown in Annex G.3.2.

8.3.4.2 Procedure

- 1) Set the test signal input \hat{E}_s/I_{ot} according to Table 8.3.5-1. The minimum I_o is -125.1 dBm/15 kHz and the maximum I_o is -50 dBm/BWchannel.
- 2) Measure the UL RTOA according to Annex E.

8.3.5 Test requirement

The LMU shall measure the UL RTOA with the accuracy at the 90th percentile as defined in table 8.3.5-1. The reference measurement channel is specified in Annex A Tables A-3 and A-4.

Table 8.3.5-1: LMU UL RTOA measurement accuracy with CA

SRS Bandwidth (RBs)	Input \hat{E}_s/I_{ot} (dB)	AWGN		EPA5		ETU30	
		Minimum number of SRS transmissions	90% RTOA (Ts)	Minimum number of SRS transmissions	90% RTOA (Ts)	Minimum number of SRS transmissions	90% RTOA (Ts)
4	-16.6	233	10	250	10	421	16
8	-16.6	71	8	77	10	127	14
12	-16.6	37	8	42	8	90	14
16	-16.6	24	8	29	10	63	12
20	-16.6	17	8	22	8	52	12
24	-16.6	14	8	18	8	44	12
32	-16.6	9	8	13	8	35	12
36	-16.6	8	6	12	8	32	12
40	-16.6	7	6	10	8	29	12
48	-16.6	5	6	9	8	25	12
60	-16.6	5	6	7	8	20	14
64	-16.6	4	6	7	8	18	14
72	-16.6	4	6	6	8	17	14
80	-16.6	3	6	6	8	15	14
96	-16.6	3	6	5	8	13	14

8.4 Parallel UL RTOA measurements on the same carrier frequency

8.4.1 Definition and applicability

This test is to verify LMU requirements in Section 7.2.3.1 of TS 36.111 and applies for LMU Class 1, Class 2, and Class 3.

The performance requirement of UL RTOA is determined by a minimum required accuracy for a given SNR, SRS bandwidth, and measurement period. The required accuracy is expressed as a multiple of Ts.

8.4.2 Minimum requirement

The minimum requirement is in TS 36.111 [2] subclause 7.2.3.1.

8.4.3 Test Purpose

To verify that the LMU can meet UL RTOA measurement accuracy requirements in different channel conditions for 16 target UE simultaneously transmitting SRS on the same carrier frequency, provided that the SRS are configured over at least a certain bandwidth for each target UE and all the 16 LMU measurements are performed in parallel over the same time period according to Table 8.4.5-1.

8.4.4 Method of testing

8.4.4.1 Initial conditions

Test environment: normal; see subclause D.2

RF channels to be tested: M; see subclause 4.7.

The following additional tests shall be performed:

On channel M, the test shall be performed under extreme power supply as defined in subclause D.3

NOTE: Tests under extreme power supply also test extreme temperature.

Connect the test equipment as shown in Annex G.3.3.

8.4.4.2 Procedure

- 1) For each UE test signal set the input \hat{E}_s/I_{ot} according to Table 8.3.5-1. The minimum I_o is -125.1 dBm/15 kHz and the maximum I_o is -50 dBm/BWchannel.
- 2) Measure the UL RTOA for 16 UEs in parallel according to Annex E.

8.4.5 Test requirement

The LMU shall measure the UL RTOA with the accuracy at the 90th percentile as defined in table 8.3.5-1. The 16 parallel reference measurement channels are defined in Annex A, Tables A-5, A-6, A-7, A-8 and A-9.

Table 8.4.5-1: LMU UL RTOA measurement accuracy for parallel measurements on one frequency carrier

SRS Bandwidth (RBs)	Input \hat{E}_s/I_{ot} (dB)	AWGN		EPA5		ETU30	
		Minimum number of SRS transmissions	90% RTOA (Ts)	Minimum number of SRS transmissions	90% RTOA (Ts)	Minimum number of SRS transmissions	90% RTOA (Ts)
4	-16.6	233	10	250	10	421	16
8	-16.6	71	8	77	10	127	14
12	-16.6	37	8	42	8	90	14
16	-16.6	24	8	29	10	63	12
20	-16.6	17	8	22	8	52	12
24	-16.6	14	8	18	8	44	12
32	-16.6	9	8	13	8	35	12
36	-16.6	8	6	12	8	32	12
40	-16.6	7	6	10	8	29	12
48	-16.6	5	6	9	8	25	12
60	-16.6	5	6	7	8	20	14
64	-16.6	4	6	7	8	18	14
72	-16.6	4	6	6	8	17	14
80	-16.6	3	6	6	8	15	14
96	-16.6	3	6	5	8	13	14

8.5 Parallel UL RTOA measurements on two carrier frequencies

8.5.1 Definition and applicability

This test is to verify LMU requirements in Section 7.2.3.2 of TS 36.111 and applies for LMU Class 1, Class 2, and Class 3.

The performance requirement of UL RTOA is determined by a minimum required accuracy for a given SNR, SRS bandwidth, and measurement period. The required accuracy is expressed as a multiple of T_s .

8.5.2 Minimum requirement

The minimum requirement is in TS 36.111 [2] subclause 7.2.3.2.

8.5.3 Test Purpose

To verify that the LMU can meet UL RTOA measurement accuracy requirements in different channel conditions for 16 target UE simultaneously transmitting SRS on a first carrier frequency and 16 target UEs simultaneously transmitting SRS on a second carrier frequency, provided that the SRS are configured over at least a certain bandwidth for each target UE and all the 32 LMU measurements are performed in parallel over the same time period according to Table 8.5.5-1.

8.5.4 Method of testing

8.5.4.1 Initial conditions

Test environment: normal; see subclause D.2

RF channels to be tested: M; see subclause 4.7.

The following additional tests shall be performed:

On channel M, the test shall be performed under extreme power supply as defined in subclause D.3

NOTE: Tests under extreme power supply also test extreme temperature.

Connect the test equipment as shown in Annex G.3.3.

8.5.4.2 Procedure

- 1) For each UE test signal set the input \hat{E}_s/I_{ot} according to Table 8.3.5-1. The minimum I_o is -125.1 dBm/15 kHz and the maximum I_o is -50 dBm/BWchannel.
- 2) Measure the UL RTOA for 32 UEs in parallel according to Annex E.

8.5.5 Test requirement

The LMU shall measure the UL RTOA with the accuracy at the 90th percentile as defined in table 8.3.5-1. The 32 parallel reference measurement channels are configured across two carrier frequencies with each carrier frequency configured with 16 channels as defined in Annex A, Tables A-5, A-6, A-7, A-8 and A-9.

Table 8.5.5-1: LMU UL RTOA measurement accuracy for parallel measurements over two frequency carriers

SRS Bandwidth (RBs)	Input Es/lot (dB)	AWGN		EPA5		ETU30	
		Minimum number of SRS transmissions	90% RTOA (Ts)	Minimum number of SRS transmissions	90% RTOA (Ts)	Minimum number of SRS transmissions	90% RTOA (Ts)
4	-16.6	233	10	250	10	421	16
8	-16.6	71	8	77	10	127	14
12	-16.6	37	8	42	8	90	14
16	-16.6	24	8	29	10	63	12
20	-16.6	17	8	22	8	52	12
24	-16.6	14	8	18	8	44	12
32	-16.6	9	8	13	8	35	12
36	-16.6	8	6	12	8	32	12
40	-16.6	7	6	10	8	29	12
48	-16.6	5	6	9	8	25	12
60	-16.6	5	6	7	8	20	14
64	-16.6	4	6	7	8	18	14
72	-16.6	4	6	6	8	17	14
80	-16.6	3	6	6	8	15	14
96	-16.6	3	6	5	8	13	14

Annex A (informative): Reference measurement channel

A.1 Reference measurement channel

Table A.1-1: SRS Configuration for receiver requirements except in-channel selectivity

Channel bandwidth	1.4 MHz	3 MHz	5 MHz	10 MHz	15 MHz	20 MHz
UL bandwidth	n6	n15	n25	n50	n75	n100
srsBandwidthConfiguration	bw7	bw5	bw3	bw5	bw6	bw5
srsBandwidth	bw0	bw0	bw0	bw1	bw2	bw2
srsHoppingBandwidth Note 2	hbw0	hbw0	hbw0	hbw1	hbw2	hbw2
frequencyDomainPosition	0	0	0	2	8	13
srs-ConfigIndex	5	5	5	5	5	5
transmissionComb	0	0	0	0	0	0
cyclicShift	cs0	cs0	cs0	cs0	cs0	cs0
srsAntennaPort	an1	an1	an1	an1	an1	an1
Number of SRS resource blocks	4	4	4	4	4	4
Number of configured SRS transmissions, as indicated by E-SMLC	≥500 (see note 1)	≥500 (see note 1)	≥500 (see note 1)	≥500 (see note 1)	≥500 (see note 1)	≥500 (see note 1)
NOTE 1: The number of SRS transmissions may also be configured as Inf.						
NOTE 2: No SRS sequence hopping, no SRS group hopping						

Table A.1-2: SRS Configuration for in-channel selectivity

Channel bandwidth	1.4 MHz	3 MHz	5 MHz	10 MHz	15 MHz	20 MHz
UL bandwidth	n6	n15	n25	n50	n75	n100
srsBandwidthConfiguration	bw7	bw5	bw5	bw5	bw6	bw5
srsBandwidth	bw0	bw1	bw1	bw1	bw2	bw2
srsHoppingBandwidth	hbw0	hbw1	hbw1	hbw1	hbw2	hbw2
frequencyDomainPosition	0	0	0	2	5	13
srs-ConfigIndex	5	5	5	5	5	5
transmissionComb	0	0	0	0	0	0
cyclicShift	cs0	cs0	cs0	cs0	cs0	cs0
srsAntennaPort	an1	an1	an1	an1	an1	an1
Number of SRS resource blocks	4	4	4	4	4	4
Number of configured SRS transmissions, as indicated by E-SMLC	≥500 (see note 1)	≥500 (see note 1)	≥500 (see note 1)	≥500 (see note 1)	≥500 (see note 1)	≥500 (see note 1)
NOTE 1: The number of SRS transmissions may also be configured as Inf.						
NOTE 2: No SRS sequence hopping, no SRS group hopping						

Table A.1-3: SRS Configuration for accuracy and measurement time requirements, $4 \leq$ SRS RBs \leq 36, single UE

Number of SRS resource blocks	4	8	12	16	20	24	32	36
Channel bandwidth	1.4 MHz	3 MHz	3 MHz	5 MHz	5 MHz	10 MHz	10 MHz	10 MHz
UL bandwidth	n6	n15	n15	n25	n25	n50	n50	n50
Physical cell ID	1	1	1	1	1	1	1	1
srsBandwidthConfiguration	bw7	bw6	bw5	bw4	bw3	bw5	bw4	bw3
srsBandwidth	bw0	bw0	bw0	bw0	bw0	bw0	bw0	bw0
srsHoppingBandwidth	hbw0	hbw0	hbw0	hbw0	hbw0	hbw0	hbw0	hbw0
frequencyDomainPosition	0	0	0	0	0	0	0	0
srs-ConfigIndex	325	325	325	325	325	325	325	325
transmissionComb	0	0	0	0	0	0	0	0
cyclicShift	cs0	cs0	cs0	cs0	cs0	cs0	cs0	cs0
srsAntennaPort	an1	an1	an1	an1	an1	an1	an1	an1
Note 1: No SRS sequence hopping, no SRS group hopping								

Table A.1-4: SRS Configuration for accuracy and measurement time requirements, $40 \leq$ SRS RBs \leq 96, single UE

Number of SRS resource blocks	40	48	60	64	72	80	96
Channel bandwidth	10 MHz	10 MHz	15 MHz	15 MHz	15 MHz	20 MHz	20 MHz
UL bandwidth	n50	n50	n75	n75	n75	n100	n100
Physical cell ID	1	1	1	1	1	1	1
srsBandwidthConfiguration	bw2	bw1	bw2	bw1	bw0	bw2	bw1
srsBandwidth	bw0	bw0	bw0	bw0	bw0	bw0	bw0
srsHoppingBandwidth	hbw0	hbw0	hbw0	hbw0	hbw0	hbw0	hbw0
frequencyDomainPosition	0	0	0	0	0	0	0
srs-ConfigIndex	325	325	325	325	325	325	325
transmissionComb	0	0	0	0	0	0	0
cyclicShift	cs0	cs0	cs0	cs0	cs0	cs0	cs0
srsAntennaPort	an1	an1	an1	an1	an1	an1	an1
Note 1: No SRS sequence hopping, no SRS group hopping							

Table A.1-5: SRS Configuration for accuracy and measurement time requirements, $4 \leq$ SRS RBs \leq 36, parallel UL RTOA measurements

Number of SRS resource blocks	4	8	12	16	20	24	32	36
Channel bandwidth	1.4 MHz	3 MHz	3 MHz	5 MHz	5 MHz	10 MHz	10 MHz	10 MHz
UL bandwidth	n6	n15	n15	n25	n25	n50	n50	n50
srsBandwidthConfiguration	bw7	bw6	bw5	bw4	bw3	bw5	bw4	bw3
srsBandwidth	bw0	bw0	bw0	bw0	bw0	bw0	bw0	bw0
srsHoppingBandwidth	hbw0	hbw0	hbw0	hbw0	hbw0	hbw0	hbw0	hbw0
frequencyDomainPosition	0	0	0	0	0	0	0	0
srs-ConfigIndex	325	325	325	325	325	325	325	325
srsAntennaPort	an1	an1	an1	an1	an1	an1	an1	an1
Note 1: No SRS sequence hopping, no SRS group hopping								

Table A.1-6: SRS Configuration for accuracy and measurement time requirements, $40 \leq$ SRS RBs \leq 96, parallel UL RTOA measurements

Number of SRS resource blocks	40	48	60	64	72	80	96
Channel bandwidth	10 MHz	10 MHz	15 MHz	15 MHz	15 MHz	20 MHz	20 MHz
UL bandwidth	n50	n50	n75	n75	n75	n100	n100
srsBandwidthConfiguration	bw2	bw1	bw2	bw1	bw0	bw2	bw1
srsBandwidth	bw0	bw0	bw0	bw0	bw0	bw0	bw0
srsHoppingBandwidth	hbw0	hbw0	hbw0	hbw0	hbw0	hbw0	hbw0
frequencyDomainPosition	0	0	0	0	0	0	0
srs-ConfigIndex	325	325	325	325	325	325	325
srsAntennaPort	an1	an1	an1	an1	an1	an1	an1
Note 1: No SRS sequence hopping, no SRS group hopping							

Table A.1-7: SRS Physical cell ID for parallel UL RTOA measurements

Channel bandwidth	1.4 MHz	3 MHz	5 MHz	10 MHz	15 MHz	20 MHz
UE number						
1	1	1	1	1	1	1
2	1	1	1	1	1	1
3	1	1	1	1	1	1
4	1	1	1	1	1	1
5	2	1	1	1	1	1
6	2	1	1	1	1	1
7	2	1	1	1	1	1
8	2	1	1	1	1	1
9	3	2	1	1	1	1
10	3	2	1	1	1	1
11	3	2	1	1	1	1
12	3	2	1	1	1	1
13	4	2	1	1	1	1
14	4	2	1	1	1	1
15	4	2	1	1	1	1
16	4	2	1	1	1	1

Table A.1-8: SRS cyclic shift for parallel UL RTOA measurements

Channel bandwidth	1.4 MHz	3 MHz	5 MHz	10 MHz	15 MHz	20 MHz
UE number						
1	cs0	cs0	cs0	cs0	cs0	cs0
2	cs4	cs2	cs1	cs1	cs1	cs1
3	cs0	cs4	cs2	cs2	cs2	cs2
4	cs4	cs6	cs3	cs3	cs3	cs3
5	cs0	cs0	cs4	cs4	cs4	cs4
6	cs4	cs2	cs5	cs5	cs5	cs5
7	cs0	cs4	cs6	cs6	cs6	cs6
8	cs4	cs6	cs7	cs7	cs7	cs7
9	cs0	cs0	cs0	cs0	cs0	cs0
10	cs4	cs2	cs1	cs1	cs1	cs1
11	cs0	cs4	cs2	cs2	cs2	cs2
12	cs4	cs6	cs3	cs3	cs3	cs3
13	cs0	cs0	cs4	cs4	cs4	cs4
14	cs4	cs2	cs5	cs5	cs5	cs5
15	cs0	cs4	cs6	cs6	cs6	cs6
16	cs4	cs6	cs7	cs7	cs7	cs7

Table A.1-9: SRS transmission comb for parallel UL RTOA measurements

Channel bandwidth UE number	1.4 MHz	3 MHz	5 MHz	10 MHz	15 MHz	20 MHz
1	0	0	0	0	0	0
2	0	0	0	0	0	0
3	1	0	0	0	0	0
4	1	0	0	0	0	0
5	0	1	0	0	0	0
6	0	1	0	0	0	0
7	1	1	0	0	0	0
8	1	1	0	0	0	0
9	0	0	1	1	1	1
10	0	0	1	1	1	1
11	1	0	1	1	1	1
12	1	0	1	1	1	1
13	0	1	1	1	1	1
14	0	1	1	1	1	1
15	1	1	1	1	1	1
16	1	1	1	1	1	1

Annex B (informative): Propagation conditions

B.1 Static Propagation condition

The propagation for the static performance measurement is an Additive White Gaussian Noise (AWGN) environment. No fading or multi-paths exist for this propagation model.

B.2 Multi-path fading propagation conditions

Tables B.2-1 – B.2.3 show multi-path delay profiles that are used for the performance measurements in multi-path fading environment. All taps have classical Doppler spectrum, defined as:

(CLASS) $S(f) \propto 1/(1 - (f/f_D)^2)^{0.5}$ for $f \in [-f_D, f_D]$.

Table B.2-1 Extended Pedestrian A model (EPA)

Excess tap delay [ns]	Relative power [dB]
0	0.0
30	-1.0
70	-2.0
90	-3.0
110	-8.0
190	-17.2
410	-20.8

Table B.2-2 Extended Typical Urban model (ETU)

Excess tap delay [ns]	Relative power [dB]
0	-1.0
50	-1.0
120	-1.0
200	0.0
230	0.0
500	0.2
1600	-3.0
2300	-5.0
5000	-7.0

Annex C (informative): Characteristics of the interfering signals

C.1 Interfering signals in LMU RF tests

The interfering signal for the 1.4 MHz in-channel requirement shall be a PUCCH. For the other requirements the interferer shall be a PUSCH containing data and reference symbols. Normal cyclic prefix is used. The data content shall be uncorrelated to the wanted signal and modulated according to clause 5 of TS 36.211 [3]. Mapping of the PUCCH and PUSCH modulation to receiver requirement are specified in table C-1.1.

Table C-1.1: Modulation of the interfering signal

Receiver requirement	Signal/Modulation
In-channel selectivity (1.4 MHz channel)	PUCCH/QPSK
In-channel selectivity (3, 5, 10, 15 and 20 MHz channel)	PUSCH/16QAM
Adjacent channel selectivity and narrow-band blocking	PUSCH/QPSK
Blocking	PUSCH/QPSK
Receiver intermodulation	PUSCH/QPSK

C.2 Interfering signals in LMU performance tests

TBD

Annex D (informative): Environmental requirements for the LMU equipment

D.1 General

For each test in the present document, the environmental conditions under which the LMU is to be tested are defined.

D.2 Normal test environment

When a normal test environment is specified for a test, the test should be performed within the minimum and maximum limits of the conditions stated in Table D.1.

Table D.1: Limits of conditions for Normal Test Environment

Condition	Minimum	Maximum
Barometric pressure	86 kPa	106 kPa
Temperature	15°C	30°C
Relative Humidity	20 %	85 %
Power supply	Nominal, as declared by the manufacturer	
Vibration	Negligible	

The ranges of barometric pressure, temperature and humidity represent the maximum variation expected in the uncontrolled environment of a test laboratory. If it is not possible to maintain these parameters within the specified limits, the actual values shall be recorded in the test report.

NOTE: This may, for instance, be the case for measurements of radiated emissions performed on an open field test site.

D.3 Extreme test environment

The manufacturer shall declare one of the following:

- 1) the equipment class for the equipment under test, as defined in the IEC 60 721-3-3 [4];
- 2) the equipment class for the equipment under test, as defined in the IEC 60 721-3-4 [5];
- 3) the equipment that does not comply to the mentioned classes, the relevant classes from IEC 60 721 documentation for Temperature, Humidity and Vibration shall be declared.

NOTE: Reduced functionality for conditions that fall outside of the standard operational conditions are not tested in the present document. These may be stated and tested separately.

D.3.1 Extreme temperature

When an extreme temperature test environment is specified for a test, the test shall be performed at the standard minimum and maximum operating temperatures defined by the manufacturer's declaration for the equipment under test.

Minimum temperature:

The test shall be performed with the environment test equipment and methods including the required environmental phenomena into the equipment, conforming to the test procedure of IEC 60 068-2-1 [6].

Maximum temperature:

The test shall be performed with the environmental test equipment and methods including the required environmental phenomena into the equipment, conforming to the test procedure of IEC 60 068-2-2 [7].

NOTE: It is recommended that the equipment is made fully operational prior to the equipment being taken to its lower operating temperature.

D.4 Vibration

When vibration conditions are specified for a test, the test shall be performed while the equipment is subjected to a vibration sequence as defined by the manufacturer's declaration for the equipment under test. This shall use the environmental test equipment and methods of inducing the required environmental phenomena in to the equipment, conforming to the test procedure of IEC 60 068-2-6 [8]. Other environmental conditions shall be within the ranges specified in clause D.2.

NOTE: The higher levels of vibration may induce undue physical stress in to equipment after a prolonged series of tests. The testing body should only vibrate the equipment during the RF measurement process.

D.5 Power supply

When extreme power supply conditions are specified for a test, the test shall be performed at the standard upper and lower limits of operating voltage defined by manufacturer's declaration for the equipment under test.

Upper voltage limit:

The equipment shall be supplied with a voltage equal to the upper limit declared by the manufacturer (as measured at the input terminals to the equipment). The tests shall be carried out at the steady state minimum and maximum temperature limits declared by the manufacturer for the equipment, to the methods described in IEC 60 068-2-1 [6] Test Ab/Ad and IEC 60 068-2-2 [7] Test Bb/Bd: Dry Heat.

Lower voltage limit:

The equipment shall be supplied with a voltage equal to the lower limit declared by the manufacturer (as measured at the input terminals to the equipment). The tests shall be carried out at the steady state minimum and maximum temperature limits declared by the manufacturer for the equipment, to the methods described in IEC 60 068-2-1 [6] Test Ab/Ad and IEC 60 068-2-2 [7] Test Bb/Bd: Dry Heat.

D.6 Measurement of test environments

The measurement accuracy of the LMU test environments defined in Annex D, Test environments shall be.

Pressure:	±5 kPa.
Temperature:	±2 degrees.
Relative Humidity:	±5 %.
DC Voltage:	±1,0 %.
AC Voltage:	±1,5 %.
Vibration:	10 %.
Vibration frequency:	0,1 Hz.

The above values shall apply unless the test environment is otherwise controlled and the specification for the control of the test environment specifies the uncertainty for the parameter.

Annex E (informative): General Rules for statistical testing

E.1 Error Definition

For the RF requirements testing, a correct event is when the LMU detects the wanted signal with the false alarm rate as specified in TS 36.111 clause 5.1.1. To pass a RF requirements test, the detection probability has to be at least 99% and the false alarm rate below 0.1%.

For the UL RTOA measurement testing, a correct event is when the LMU returns a measurement response with a correct UL RTOA measurement within the time as specified in clauses 7.2.5, 7.3.5 and 7.4.5, whichever applies. To pass a UL RTOA measurement test, at least 90% of the events have to be correct.

For the UL RTOA measurement accuracy testing, a correct event is when the LMU returns a measurement response with a correct UL RTOA measurement that has a value less than or equal to the corresponding required value in Tables 8.2.5-1, 8.3.5-1, 8.4.5-1 and 8.5.5-1, whichever applies. To pass a UL RTOA measurement accuracy test, at least 90% of the events have to be correct.

E.2 Test Method

Each test is performed in the following manner:

- a) Setup the required test conditions.
- b) Record the number of samples tested and the number of correct events.
- c) Stop the test when the number of correct events is sufficient to pass the test or after a given time.
- d) Once the test is stopped decide whether the test has been passed or not.

Annex F (informative): Test tolerances and derivation of test requirements

F.1 Test tolerances and derivation of test requirements

The Test Requirements in this specification have been calculated by relaxing the Minimum Requirements of the core specification using the Test Tolerances defined in clause 4. When the Test Tolerance is zero, the Test Requirement will be the same as the Minimum Requirement. When the Test Tolerance is non-zero, the Test Requirements will differ from the Minimum Requirements, and the formula used for this relaxation is given in tables F.1, F.2 and F.3.

Note that a formula for applying Test Tolerances is provided for all tests, even those with a test tolerance of zero. This is necessary in the case that the Test System uncertainty is greater than that allowed in clause 4. In this event, the excess error shall be subtracted from the defined test tolerance in order to generate the correct tightened Test Requirements as defined in clause 4.

For example, a Test System having 0.9 dB accuracy for test 6.2.1 LMU Reference sensitivity (which is 0.2 dB above the limit specified in clause 4.) would subtract 0.2 dB from the Test Tolerance of 0.7 dB defined in clause 4. This new test tolerance of 0.5 dB would then be applied to the Minimum Requirement using the formula defined in Table F.1-1 to give a new wanted signal power of -130.3 dBm for the reference sensitivity.

Using this same approach for the case where a test had a test tolerance of 0 dB, an excess error of 0.2 dB would result in a modified test tolerance of -0.2 dB.

Table F.1-1: Derivation of RF Test Requirements

Test	Test Tolerance (TT)	Test Requirement in TS 36.112
6.2 Reference sensitivity	0.7 dB, $f \leq 3.0$ GHz 1.0 dB, $3.0 \text{ GHz} < f \leq 4.2$ GHz	Formula: Reference sensitivity level + TT
6.3 Dynamic range	0.3 dB	Formula: Wanted signal level + TT AWGN level unchanged
6.4 In-channel selectivity	1.4 dB, $f \leq 3.0$ GHz 1.8 dB, $3.0 \text{ GHz} < f \leq 4.2$ GHz	Formula: Wanted signal level + TT W-CDMA interferer level unchanged
6.5 Adjacent channel selectivity (ACS) and narrowband blocking	1.4 dB, $f \leq 3.0$ GHz 1.8 dB, $3.0 \text{ GHz} < f \leq 4.2$ GHz	Formula: Wanted signal level + TT Interferer level unchanged
6.6 Blocking	<u>In-band blocking, using modulated interferer:</u> 1.6 dB, $f \leq 3.0$ GHz 2.0 dB, $3.0\text{GHz} < f \leq 4.2\text{GHz}$ <u>Out of band blocking, using CW interferer:</u> 1.3 dB, $1\text{MHz} < f_{\text{interferer}} \leq 3$ GHz 1.6 dB, $3.0\text{GHz} < f_{\text{interferer}} \leq 4.2$ GHz 3.2 dB, $4.2\text{GHz} < f_{\text{interferer}} \leq 12.75$ GHz	Formula: Wanted signal level + TT Interferer level unchanged
6.7 Receiver spurious emissions	2.0 dB, $30 \text{ MHz} \leq f \leq 4$ GHz 4.0 dB, $4 \text{ GHz} < f \leq 19$ GHz	Add TT to Maximum level in table 6.7.5-1
6.7 Receiver intermodulation	± 1.8 dB, $f \leq 3.0\text{GHz}$ ± 2.4 dB, $3.0\text{GHz} < f \leq 4.2\text{GHz}$	Formula: Wanted signal level + TT Interferer1 level unchanged Interferer2 level unchanged

Table F.1-2: Derivation of UL RTOA Measurement Time Requirements

Test	Test Tolerance (TT)	Test Requirement in TS 36.112
7.2, Requirements for FDD without DRX	0.3 dB	Minimum requirement + TT
7.3, Requirements for TDD without DRX	0.3 dB	Minimum requirement + TT

Table F.1-3: Derivation of UL RTOA Accuracy Requirements

Test	Test Tolerance (TT)	Test Requirement in TS 36.112
8.2, UL RTOA measurement accuracy for a UE not configured with CA	0.3 dB	Minimum requirement + TT
8.3, UL RTOA measurement accuracy for a UE configured with CA	0.3 dB	Minimum requirement + TT
8.4 UL RTOA measurement accuracy when LMU is performing multiple UL RTOA measurements in parallel	0.3 dB	Minimum requirement + TT

Annex G (informative): Measurement system setup

G.1 Receiver RF Requirements Testing

The measurement set-ups in this clause are for the LMU RF requirements for class 2 and class 3 LMUs specified in Section 5 of TS 36.111. The test ports and the RF requirements applicability are as specified in Section 5.1 of TS 36.111. If any external apparatus, e.g., a RX amplifier, a filter or the combination of such devices is used, LMU RF requirements apply and are tested at the far end antenna connector (port B); otherwise, the requirements apply at port A. No additional testing is necessary for class 1 LMUs, in addition to base station conformance tests specified in TS 36.141.

Degradation of the base station DL performance and base station UL performance may occur when LMU class 2 is co-sited with the base station; therefore the impact on BS shall also be tested in conjunction with the LMU Receiver RF conformance tests of this specification.

G.1.1 Receiver sensitivity level

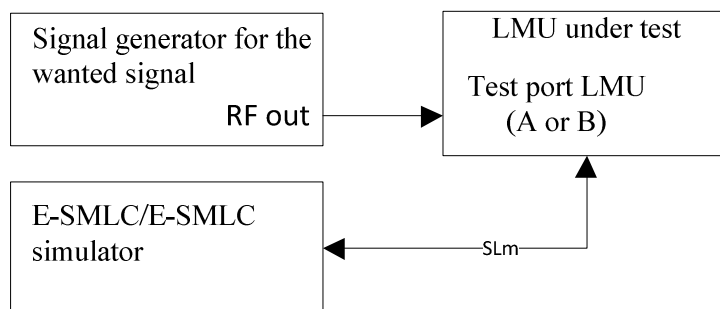

Figure G.1.1-1 Measuring system setup for class 2 and class 3 LMU receiver sensitivity level

G.1.2 Dynamic range

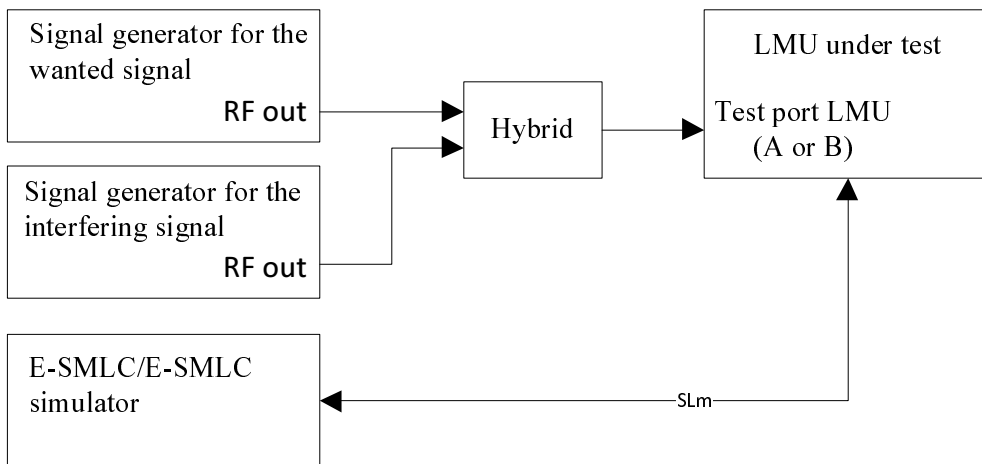

Figure G.1.2-1 Measuring system setup for class 2 and class 3 LMU dynamic range

G.1.3 In-channel selectivity

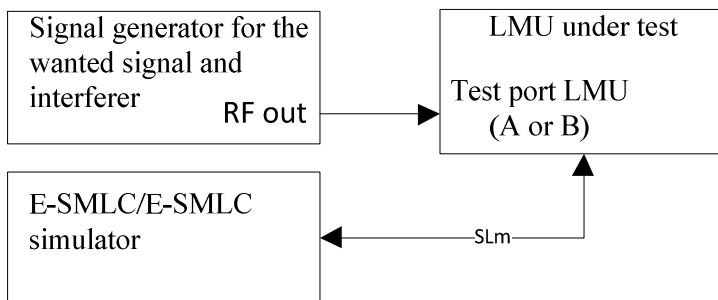

Figure G.1.3-1 Measuring system setup for class 2 and class 3 LMU In-channel selectivity

G.1.4 Adjacent channel selectivity (ACS) and narrow-band blocking

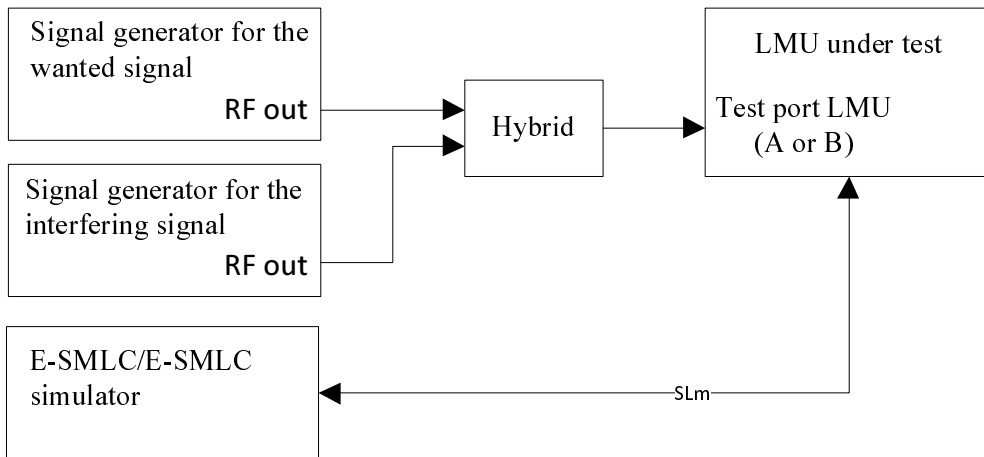

Figure G.1.4-1 Measuring system setup for LMU Adjacent channel selectivity and narrow-band blocking

G.1.5 Blocking

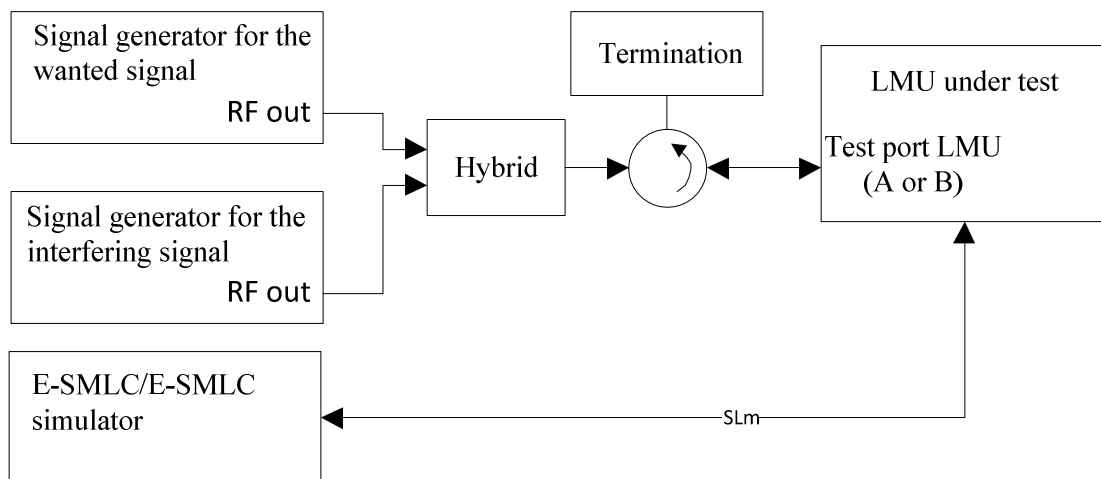

Figure G.1.5-1 Measuring system setup for class 2 and class 3 LMU Blocking

G.1.6 Receiver spurious emissions

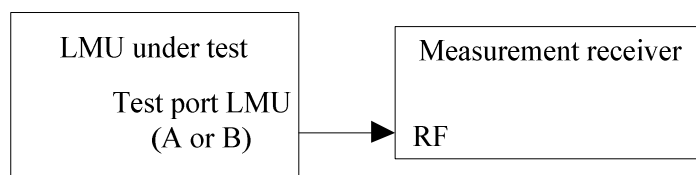

Figure G.1.6-1 Measuring system setup for class 2 and class 3 LMU Receiver spurious emissions

G.1.7 Receiver intermodulation

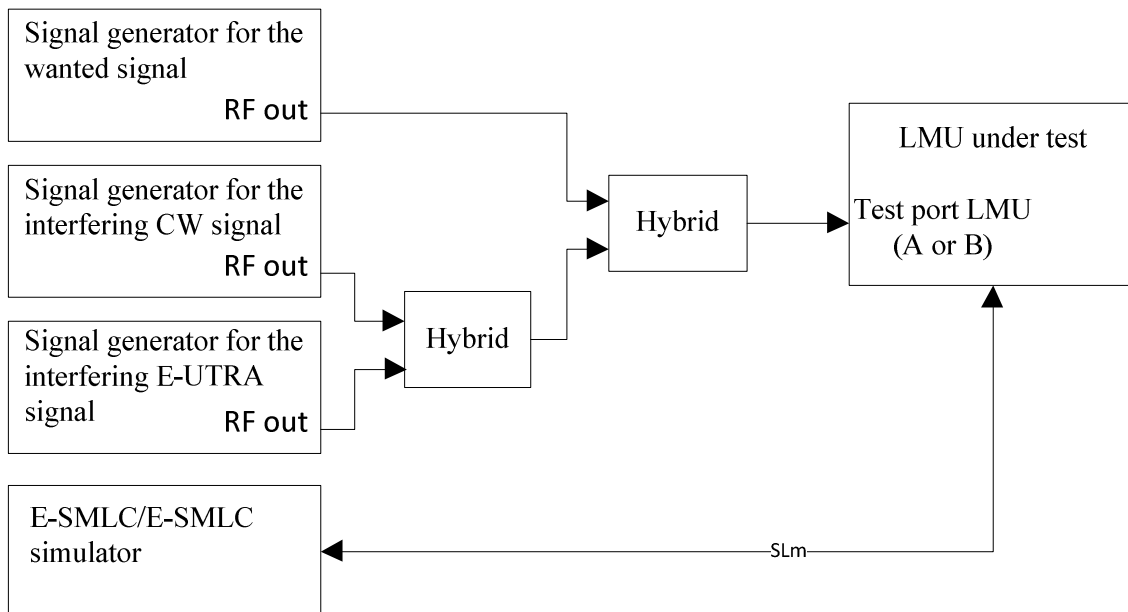

Figure G.1.7-1 Measuring system setup for class 2 and class 3 LMU Receiver intermodulation

G.2 UL RTOA measurement time requirements Testing

The measurement set-ups for the UL RTOA measurement time are common to class 1, class 2 and class 3 LMUs. The test ports are as specified in Section 5.1 of TS 36.111. If any external apparatus, e.g., a RX amplifier, a filter or the combination of such devices is used, the LMU requirements are tested at the far end antenna connector (port B); otherwise, the requirements apply at port A.

G.2.1 UL RTOA measurement time, FDD without DRX

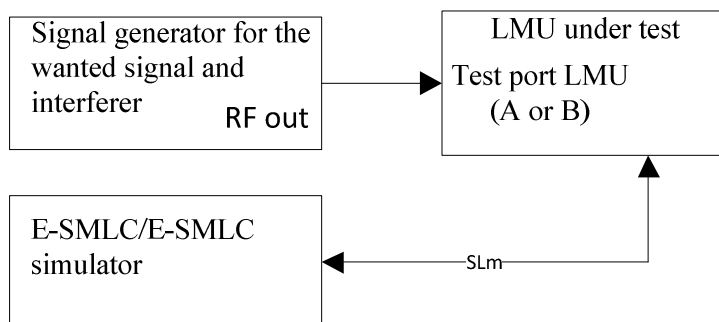

Figure G.2.1-1 Measuring system setup for LMU UL RTOA measurement time, FDD without DRX

G.2.2 UL RTOA measurement time, TDD without DRX

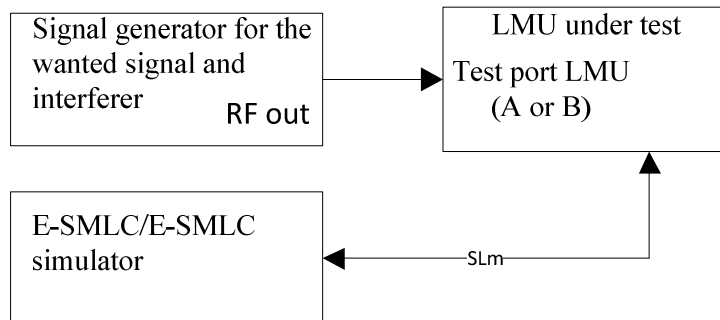

Figure G.2.2-1 Measuring system setup for LMU UL RTOA measurement time, TDD without DRX

G.3 UL RTOA measurement accuracy requirements Testing

The measurement set-ups for the UL RTOA measurement accuracy are common to class 1, class 2 and class 3 LMUs. The test ports are as specified in Section 5.1 of TS 36.111. If any external apparatus, e.g., a RX amplifier, a filter or the combination of such devices is used, the LMU requirements are tested at the far end antenna connector (port B); otherwise, the requirements apply at port A.

G.3.1 UL RTOA measurement accuracy for a UE not configured with CA

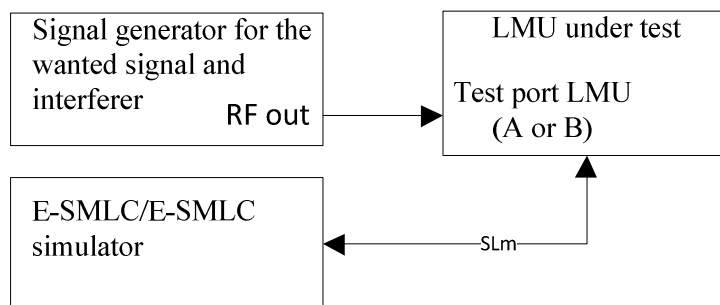

Figure G.1.3-1 Measuring system setup for UL RTOA measurement accuracy for LMU without CA

G.3.2 UL RTOA measurement accuracy for a UE configured with CA

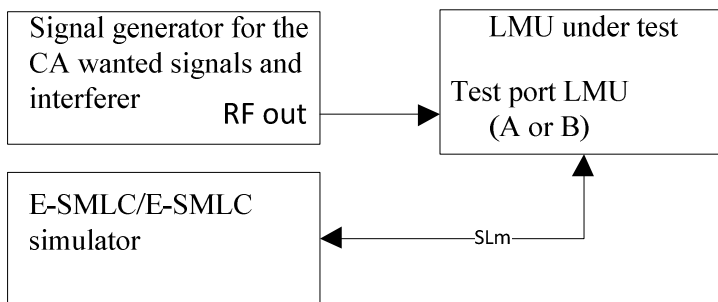

Figure G.3.2-1 Measuring system setup for UL RTOA measurement accuracy for LMU with CA

G.3.3 UL RTOA measurement accuracy when LMU is performing multiple UL RTOA measurements in parallel

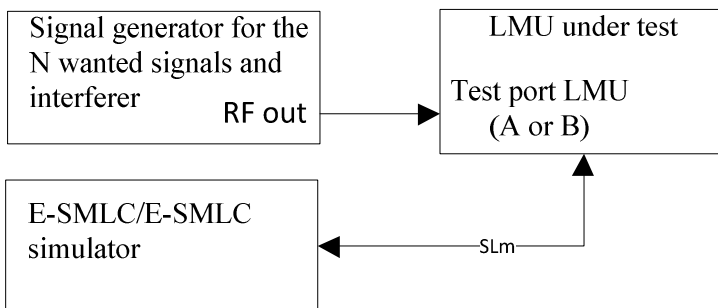

Figure G.3.3-1 Measuring system setup for UL RTOA measurement accuracy with multiple parallel measurements

Annex H (informative): Change history

Change history							
Date	TSG #	TSG Doc.	CR	Rev	Subject/Comment	Old	New
2013-11					Submission to RAN4#69.	0.1.0	0.2.0
2014-03					adding modifications in R4-141161 from RAN4#70, and modifications from R4-142333, R4-142334, R4-142425, R4-142426 and agreed text following discussion of R4-141395 from RAN4#70bis.	0.2.0	0.3.0
2014-05					Formatting and editorial cleanup.	0.3.0	0.4.0
2014-05					Incorporated R4-143898, R4-143899, R4-143938.	0.4.0	0.5.0
2014-06	RP#64				Version 1.0.0, presented to RAN#64 for approval	0.5.0	1.0.0
2014-06	RP#64				TR approved by the RAN plenary	1.0.0	11.0.0
2014-09	SP-65	-	-	-	Update to Rel-12 version (MCC)	11.0.0	12.0.0

History

Document history		
V12.0.0	October 2014	Publication