

ETSI TS 136 401 V8.6.0 (2009-07)

Technical Specification

**LTE;
Evolved Universal Terrestrial Radio
Access Network (E-UTRAN);
Architecture description
(3GPP TS 36.401 version 8.6.0 Release 8)**



ReferenceRTS/TSGR-0336401v860

Keywords

LTE

ETSI

650 Route des Lucioles
F-06921 Sophia Antipolis Cedex - FRANCE

Tel.: +33 4 92 94 42 00 Fax: +33 4 93 65 47 16

Siret N° 348 623 562 00017 - NAF 742 C
Association à but non lucratif enregistrée à la
Sous-Préfecture de Grasse (06) N° 7803/88

Important notice

Individual copies of the present document can be downloaded from:

<http://www.etsi.org>

The present document may be made available in more than one electronic version or in print. In any case of existing or perceived difference in contents between such versions, the reference version is the Portable Document Format (PDF). In case of dispute, the reference shall be the printing on ETSI printers of the PDF version kept on a specific network drive within ETSI Secretariat.

Users of the present document should be aware that the document may be subject to revision or change of status. Information on the current status of this and other ETSI documents is available at

<http://portal.etsi.org/tb/status/status.asp>

If you find errors in the present document, please send your comment to one of the following services:

http://portal.etsi.org/chaicor/ETSI_support.asp

Copyright Notification

No part may be reproduced except as authorized by written permission.
The copyright and the foregoing restriction extend to reproduction in all media.

© European Telecommunications Standards Institute 2009.
All rights reserved.

DECT™, **PLUGTESTS™**, **UMTS™**, **TIPHON™**, the TIPHON logo and the ETSI logo are Trade Marks of ETSI registered for the benefit of its Members.

3GPP™ is a Trade Mark of ETSI registered for the benefit of its Members and of the 3GPP Organizational Partners.

LTE™ is a Trade Mark of ETSI currently being registered

for the benefit of its Members and of the 3GPP Organizational Partners.

GSM® and the GSM logo are Trade Marks registered and owned by the GSM Association.

Intellectual Property Rights

IPRs essential or potentially essential to the present document may have been declared to ETSI. The information pertaining to these essential IPRs, if any, is publicly available for **ETSI members and non-members**, and can be found in ETSI SR 000 314: *"Intellectual Property Rights (IPRs); Essential, or potentially Essential, IPRs notified to ETSI in respect of ETSI standards"*, which is available from the ETSI Secretariat. Latest updates are available on the ETSI Web server (<http://webapp.etsi.org/IPR/home.asp>).

Pursuant to the ETSI IPR Policy, no investigation, including IPR searches, has been carried out by ETSI. No guarantee can be given as to the existence of other IPRs not referenced in ETSI SR 000 314 (or the updates on the ETSI Web server) which are, or may be, or may become, essential to the present document.

Foreword

This Technical Specification (TS) has been produced by ETSI 3rd Generation Partnership Project (3GPP).

The present document may refer to technical specifications or reports using their 3GPP identities, UMTS identities or GSM identities. These should be interpreted as being references to the corresponding ETSI deliverables.

The cross reference between GSM, UMTS, 3GPP and ETSI identities can be found under <http://webapp.etsi.org/key/queryform.asp>.

Contents

Intellectual Property Rights	2
Foreword.....	2
Foreword.....	5
1 Scope	6
2 References	6
3 Definitions and abbreviations.....	7
3.1 Definitions	7
3.2 Abbreviations	7
4 General principles	8
5 General architecture	8
5.1 General	8
5.2 User plane.....	8
5.3 Control plane.....	9
6 E-UTRAN architecture.....	10
6.1 Overview	10
6.2 E-UTRAN Identifiers	10
6.2.1 The principle of handling of Application Protocol Identities	10
6.2.2 PLMN Identity.....	11
6.2.3 Globally Unique MME Identifier (GUMMEI)	11
6.2.4 Global eNB ID.....	11
6.2.5 E-UTRAN Cell Global Identifier (ECGI).....	11
6.2.6 Tracking Area Identity.....	12
6.2.7 E-RAB ID.....	12
6.2.8 UE Identifiers.....	12
6.2.8.1 RNTI	12
6.2.8.2 S-Temporary Mobile Subscriber Identity (S-TMSI).....	12
6.3 Transport Addresses	12
6.4 UE associations in eNB	12
7 E-UTRAN functions description.....	13
7.1 List of functions	13
7.2 Functions description	13
7.2.1 Transfer of user data	13
7.2.2 Radio channel ciphering and deciphering	14
7.2.3 Integrity protection	14
7.2.4 Header compression.....	14
7.2.5 Mobility control functions	14
7.2.5.1 Handover.....	14
7.2.5.2 void	14
7.2.5.3 Positioning	14
7.2.6 Inter-cell interference coordination.....	14
7.2.7 Connection setup and release.....	14
7.2.8 Load balancing.....	14
7.2.9 Distribution function for NAS messages	15
7.2.10 NAS node selection function	15
7.2.11 Synchronization	15
7.2.12 Radio access network sharing.....	15
7.2.13 MBMS function	15
7.2.14 Subscriber and equipment trace.....	15
7.2.15 RAN Information Management	15
7.2.16 Paging	15
8 Mobility management.....	16

8.1	Signalling connection	16
8.2	Consequences for mobility handling	16
9	Synchronization.....	16
9.1	eNB Synchronisation.....	16
10	void.....	17
11	E-UTRAN interfaces.....	17
11.1	General protocol model for E-UTRAN interfaces.....	17
11.1.1	Radio Network Layer and Transport Network Layer	17
11.1.2	Control plane	18
11.1.3	User plane	18
11.2	Iuant Interface - general principles.....	18
Annex A (informative):	Change History	19
History		20

Foreword

This Technical Specification has been produced by the 3rd Generation Partnership Project (3GPP).

The contents of the present document are subject to continuing work within the TSG and may change following formal TSG approval. Should the TSG modify the contents of the present document, it will be re-released by the TSG with an identifying change of release date and an increase in version number as follows:

Version x.y.z

where:

- x the first digit:
 - 1 presented to TSG for information;
 - 2 presented to TSG for approval;
 - 3 or greater indicates TSG approved document under change control.
- y the second digit is incremented for all changes of substance, i.e. technical enhancements, corrections, updates, etc.
- z the third digit is incremented when editorial only changes have been incorporated in the document.

1 Scope

The present document describes the overall architecture of the E-UTRAN, including internal interfaces and assumptions on the radio, S1 and X2 interfaces.

2 References

The following documents contain provisions which, through reference in this text, constitute provisions of the present document.

- References are either specific (identified by date of publication, edition number, version number, etc.) or non-specific.
- For a specific reference, subsequent revisions do not apply.
- For a non-specific reference, the latest version applies. In the case of a reference to a 3GPP document (including a GSM document), a non-specific reference implicitly refers to the latest version of that document *in the same Release as the present document*.

- [1] 3GPP TR 21.905: "Vocabulary for 3GPP Specifications".
- [2] 3GPP TS 36.300: " Evolved Universal Terrestrial Radio Access (E-UTRA) and Evolved Universal Terrestrial Radio Access Network (E-UTRAN) Overall description Stage 2".
- [3] 3GPP TS 23.401: " GPRS enhancements for E-UTRAN access".
- [4] 3GPP TS 36.414: " Evolved Universal Terrestrial Access Network (E-UTRAN); S1 data transport".
- [5] 3GPP TS 36.424: " Evolved Universal Terrestrial Access Network (E-UTRAN); X2 data transport".
- [6] 3GPP TS 36.440: "Evolved Universal Terrestrial Radio Access Network (E-UTRAN); General aspects and principles for interfaces supporting Multimedia Broadcast Multicast Service (MBMS) within E-UTRAN".
- [7] ITU-T Recommendation G.823 (3/00): "The control of jitter and wander within digital networks which are based on the 2048 kbit/s hierarchy".
- [8] ITU-T Recommendation G.824 (3/00): "The control of jitter and wander within digital networks which are based on the 1544 kbit/s hierarchy".
- [9] ITU-T Recommendation G.825 (8/01): "The control of jitter and wander within digital networks which are based on the synchronous digital hierarchy (SDH)".
- [10] ITU-T Recommendation G.8261/Y.1361 (2/08): "Timing and Synchronization aspects in Packet networks".
- [11] 3GPP TS 23.003: "Numbering, addressing and identification".
- [12] 3GPP TR 44.901: "External Network Assisted Cell Change".
- [13] 3GPP TS 48.018: "General Packet Radio Service (GPRS); BSS GPRS Protocol (BSSGP)".

3 Definitions and abbreviations

3.1 Definitions

For the purposes of the present document, the following terms and definitions apply:

E-RAB: An E-RAB uniquely identifies the concatenation of an S1 Bearer and the corresponding Data Radio Bearer. When an E-RAB exists, there is a one-to-one mapping between this E-RAB and an EPS bearer of the Non Access Stratum as defined in [3].

S1: interface between an eNB and an EPC, providing an interconnection point between the E-UTRAN and the EPC. It is also considered as a reference point.

X2: logical interface between two eNBs. Whilst logically representing a point to point link between eNBs, the physical realization need not be a point to point link.

3.2 Abbreviations

For the purposes of the present document, the terms and definitions given in TR 21.905 [1] and the following apply. A term defined in the present document takes precedence over the definition of the same term, if any, in TR 21.905 [1].

AP	Application Protocol
C-RNTI	Cell RNTI
ECGI	E-UTRAN Cell Global Identifier
ECM	EPS Connection Management
EEC	Ethernet Equipment Clock
eNB	E-UTRAN Node B
EMM	EPS Mobility Management
E-RAB	E-UTRAN Radio Access Bearer
ESM	EPS Session Management
ETWS	Earthquake and Tsunami Warning System
EPC	Evolved Packet Core
EPS	Evolved Packet System
E-UTRA	Evolved UTRA
E-UTRAN	Evolved UTRAN
FDD	Frequency Division Duplex
GUMMEI	Globally Unique MME Identifier
ID	Identity
IP	Internet Protocol
LTE	Long Term Evolution
MBMS	Multimedia Broadcast Multicast Service
MBSFN	Multimedia Broadcast multicast service Single Frequency Network
NDS	Network Domain Security
MME	Mobility Management Entity
NAS	Non Access Stratum
PLMN	Public Land Mobile Network
RA-RNTI	Random Access RNTI
RET	Remote Electrical Tilting
RIM	RAN Information Management
RNL	Radio Network Layer
RNTI	Radio Network Temporary Identifier
RRC	Radio Resource Control
RTP	Real-time Transport Protocol
QoS	Quality of Service
SFN	System Frame Number
S-GW	Serving Gateway
S-TMSI	S-Temporary Mobile Subscriber Identity
TCP	Transmission Control Protocol
TDD	Time Division Duplex

TDM	Time Division Multiplexing
TMA	Tower Mounted Amplifier
TNL	Transport Network Layer
UDP	User Datagram Protocol
UE	User Equipment
UMTS	Universal Mobile Telecommunication System

4 General principles

The general principles guiding the definition of E-UTRAN Architecture as well as the E-UTRAN interfaces are the following:

- Logical separation of signalling and data transport networks.
- E-UTRAN and EPC functions are fully separated from transport functions. Addressing scheme used in E-UTRAN and EPC shall not be tied to the addressing schemes of transport functions. The fact that some E-UTRAN or EPC functions reside in the same equipment as some transport functions does not make the transport functions part of the E-UTRAN or the EPC.
- Mobility for RRC connection is fully controlled by the E-UTRAN.
- When defining the E-UTRAN interfaces the following principles were followed: the functional division across the interfaces shall have as few options as possible.
- Interfaces should be based on a logical model of the entity controlled through this interface.
- One physical network element can implement multiple logical nodes.

5 General architecture

5.1 General

The protocols over Uu and S1 interfaces are divided into two structures:

- **User plane protocols**
These are the protocols implementing the actual E-RAB service, i.e. carrying user data through the access stratum.
- **Control plane protocols**
These are the protocols for controlling the E-RABs and the connection between the UE and the network from different aspects (including requesting the service, controlling different transmission resources, handover etc.). Also a mechanism for transparent transfer of NAS messages is included.

5.2 User plane

The E-RAB service is offered from SAP to SAP by the Access Stratum. Figure 5.2-1 shows the protocols on the Uu and S1 interfaces that linked together provide this E-RAB service.

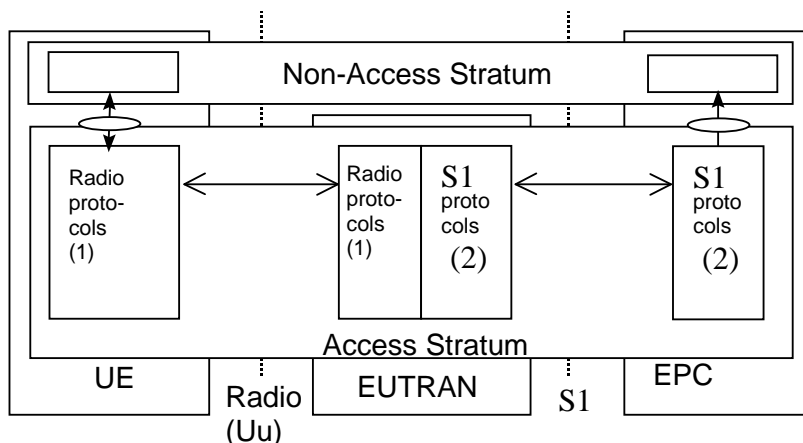

- (1) The radio interface protocols are defined in documents TS 36.2xx and TS 36.3xx.
- (2) The S1 interface protocols are defined in documents TS 36.41x.

Figure 5.2-1: S1 and Uu user plane

5.3 Control plane

Figure 5.3-1 shows the control plane (signalling) protocol stacks on S1 and Uu interfaces.

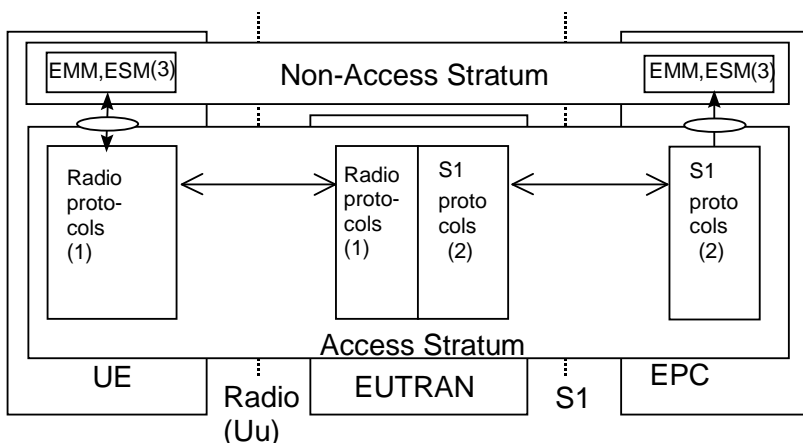

- (1) The radio interface protocols are defined in documents TS 36.2xx and TS 36.3xx.
- (2) The protocol is defined in documents TS 36.41x. (Description of S1 interface).
- (3) **EMM, ESM:** This exemplifies a set of NAS control protocols between UE and EPC. The evolution of the protocol architecture for these protocols is outside the scope of the present document.

Figure 5.3-1: S1 and Uu control plane

NOTE: Both the Radio protocols and the S1 protocols contain a mechanism to transparently transfer NAS messages.

6 E-UTRAN architecture

6.1 Overview

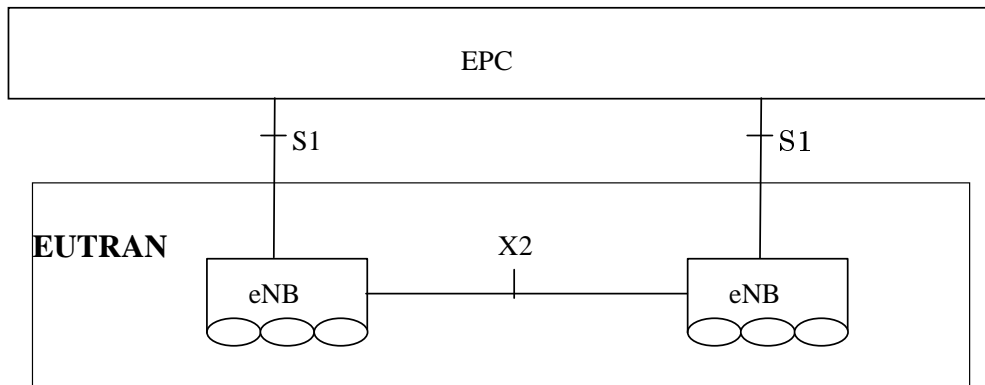

Figure 6.1-1 Overall architecture

The LTE architecture can be further described as follow:

The E-UTRAN consists of set of eNBs connected to the EPC through the S1.

An eNB can support FDD mode, TDD mode or dual mode operation.

eNBs can be interconnected through the X2.

S1 and X2 are logical interfaces.

The E-UTRAN is layered into a Radio Network Layer (RNL) and a Transport Network Layer (TNL).

The E-UTRAN Architecture, i.e. the E-UTRAN logical nodes and interfaces between them, is defined as part of the Radio Network Layer.

For each E-UTRAN interface (S1, X2) the related transport network layer protocol and functionality is specified. The transport network layer provides services for user plane transport, signalling transport.

In S1-Flex configuration, each eNB is connected to all EPC nodes within a pool area. The pool area is defined in [3].

If Security protection for control plane and user plane data on transport network layer of E-UTRAN interfaces has to be supported, NDS/IP [33.210 and (TS successor of) 33.821] shall be applied.

The eMBMS architecture is defined as in TS 36.440[6].

6.2 E-UTRAN Identifiers

This subclause shows those identifiers that are used in E-UTRAN.

6.2.1 The principle of handling of Application Protocol Identities

An Application Protocol Identity (AP ID) is allocated when a new UE-associated logical connection is created in either an eNB or an MME. An AP ID shall uniquely identify a logical connection associated to a UE over the S1 interface or X2 interface within a node (eNB or MME). Upon receipt of a message that has a new AP ID from the sending node, the receiving node shall store the AP ID of the sending node for the duration of the logical connection. The receiving node shall assign the AP ID to be used to identify the logical connection associated to the UE and include it as well as the previously received new AP ID from the sending node, in the first returned message to the sending node. In all subsequent messages to and from sending node, both AP IDs of sending node and receiving node shall be included.

The definitions of AP IDs as used on S1 interface or X2 interface are shown below:

eNB UE S1AP ID:

A eNB UE S1AP ID shall be allocated so as to uniquely identify the UE over the S1 interface within an eNB. When an MME receives an eNB UE S1AP ID it shall store it for the duration of the UE-associated logical S1-connection for this UE. Once known to an MME this IE is included in all UE associated S1-AP signalling. The eNB UE S1AP ID shall be unique within the eNB logical node.

MME UE S1AP ID:

A MME UE S1AP ID shall be allocated so as to uniquely identify the UE over the S1 interface within the MME. When an eNB receives MME UE S1AP ID it shall store it for the duration of the UE-associated logical S1-connection for this UE. Once known to an eNB this IE is included in all UE associated S1-AP signalling. The MME UE S1AP ID shall be unique within the MME logical node.

Old eNB UE X2AP ID:

An Old eNB UE X2AP ID shall be allocated so as to uniquely identify the UE over the X2 interface within a source eNB. When a target eNB receives an Old eNB UE X2AP ID it shall store it for the duration of the UE-associated logical X2-connection for this UE. Once known to a target eNB this IE is included in all UE associated X2-AP signalling. The Old eNB UE X2AP ID shall be unique within the eNB logical node.

New eNB UE X2AP ID:

An New eNB UE X2AP ID shall be allocated so as to uniquely identify the UE over the X2 interface within a target eNB. When a source eNB receives a New eNB UE X2AP ID it shall store it for the duration of the UE-associated logical X2-connection for this UE. Once known to source eNB this IE is included in all UE associated X2-AP signalling. The New eNB UE X2AP ID shall be unique within the eNB logical node.

eNB1 Measurement ID:

An eNB1 Measurement ID shall be allocated so as to uniquely identify the measurement configuration over the X2 interface within the eNB that requests the measurement. The eNB1 Measurement ID shall be unique within the eNB logical node.

eNB2 Measurement ID:

An eNB2 Measurement ID shall be allocated so as to uniquely identify the measurement configuration over the X2 interface within the eNB that performs the measurement. The eNB2 Measurement ID shall be unique within the eNB logical node.

6.2.2 PLMN Identity

A Public Land Mobile Network is uniquely identified by its PLMN Identity.

6.2.3 Globally Unique MME Identifier (GUMMEI)

The Globally Unique MME Identifier consists of a PLMN Identity, a MME Group Identity and a MME Code, as defined in [11].

An MME logical node may be associated with one or more GUMMEI, but each GUMMEI uniquely identifies an MME logical node [11].

6.2.4 Global eNB ID

The Global eNB ID, used to globally identify an eNB, is defined in [2].

6.2.5 E-UTRAN Cell Global Identifier (ECGI)

The ECGI, used to globally identify a cell, is defined in [2].

6.2.6 Tracking Area Identity

This is the identity used to identify tracking areas.

6.2.7 E-RAB ID

An E-RAB ID uniquely identifies an E-RAB for one UE accessing via E-UTRAN.

6.2.8 UE Identifiers

6.2.8.1 RNTI

Radio Network Temporary Identifiers (RNTI) are used as UE identifiers within E-UTRAN and in signalling messages between UE and E-UTRAN. Some types of RNTI exist:

1) C-RNTI

The C-RNTI provides a unique UE identification at the cell level identifying RRC Connection

2) RA-RNTI

The RA-RNTI is used during some transient states, the UE is temporarily identified with a random value for contention resolution purposes

6.2.8.2 S-Temporary Mobile Subscriber Identity (S-TMSI)

The S-TMSI is a temporary UE identity in order to support the subscriber identity confidentiality. This S-TMSI is allocated by MME.

6.3 Transport Addresses

The transport layer address parameter is transported in the radio network application signalling procedures that result in establishment of transport bearer connections.

The transport layer address parameter shall not be interpreted in the radio network application protocols and reveal the addressing format used in the transport layer.

The formats of the transport layer addresses are further described in [4], [5].

6.4 UE associations in eNB

There are several types of UE associations needed in the eNB: the "eNB UE Context" used to store all information needed for a UE in active state and the associations between the UE and the logical S1 and X2 connections used for S1/X2-AP UE associated messages.

Definitions:

eNB UE context:

An eNB UE context is a block of information in an eNB associated to one active UE. The block of information contains the necessary information required to maintain the E-UTRAN services towards the active UE. At least UE state information, security information, UE capability information and the identities of the UE-associated logical S1-connection shall be included in the eNB UE context. An eNB UE context is established when the transition to active state for a UE is completed or in target eNB after completion of handover resource allocation during handover preparation.

UE-associated logical S1-connection/ UE-associated logical X2-connection:

On the logical S1 or X2 connection, control plane messages (S1AP, X2AP) associated with the UE are sent. This connection is established during the first S1/X2AP message exchange between the S1/X2 peer nodes. The connection is

maintained as long as UE associated S1/X2AP messages need to be exchanged over S1/X2. The UE-associated logical S1-connection uses the identities MME UE S1AP ID and eNB UE S1AP ID. The UE-associated logical X2-connection uses the identities Old eNB UE X2AP ID and New eNB UE X2AP ID. When a node (MME or eNB) receives a UE associated S1/X2AP message the node retrieves the associated UE based on the S1/X2AP ID.

UE-associated signalling:

UE-associated signalling is an exchange of S1/X2-AP messages associated with one UE over the UE-associated logical S1/X2-connection.

NOTE: The UE-associated logical S1-connection may exist before the eNB UE context is setup in eNB. The UE-associated logical X2-connection may exist before the eNB UE context is setup in the target eNB.

7 E-UTRAN functions description

7.1 List of functions

- Transfer of user data
- Radio channel ciphering and deciphering
- Integrity protection
- Header compression
- Mobility control functions:
 - Handover
 - Paging
 - Positioning
- Inter-cell interference coordination
- Connection setup and release
- Load Balancing
- Distribution function for NAS messages
- NAS node selection function
- Synchronization
- Radio access network sharing
- MBMS function
- Subscriber and equipment trace
- RAN Information Management

7.2 Functions description

7.2.1 Transfer of user data

This function provides user data transfer capability across the E-UTRAN between the S1 and Uu interfaces.

7.2.2 Radio channel ciphering and deciphering

This function is a pure computation function whereby the radio transmitted data can be protected against a non-authorized third-party. Ciphering and deciphering may be based on the usage of a session-dependent key, derived through signalling and/or session dependent information.

7.2.3 Integrity protection

This function is a pure computation function whereby the transmitted data can be protected against a non-authorized third-party from alteration.

7.2.4 Header compression

This function provides a header compression specifically to the particular network layer, transport layer or upper layer protocol combination e.g. TCP/IP and RTP/UDP/IP.

7.2.5 Mobility control functions

7.2.5.1 Handover

This function manages the mobility of the radio interface. It is based on radio measurements and it is used to maintain the Quality of Service requested by the EPC. It contains the function of transferring context data between source node and target node.

Handover may be directed to/from another system (e.g. LTE to UMTS handover).

The handover preparation is done in the target network side and final handover decision is done in the source network side.

7.2.5.2 void

7.2.5.3 Positioning

This function provides the capability to determine the EUTRAN CGI a UE is currently located.

7.2.6 Inter-cell interference coordination

This function is to manage radio resources (i.e. the radio resource blocks) such that inter-cell interference is kept under control. This function is a multi-cell RRM function that needs to take into account information (e.g. the resource usage status and traffic load situation) from multiple cells.

7.2.7 Connection setup and release

This function is responsible for the control of connection element set-up and release in the E-UTRAN. The purpose of this function is:

- 1) to participate in the processing of the end-to-end connection set-up and release; and
- 2) to manage and maintain the element of the end-to-end connection which is located in the E-UTRAN.

In the former case, this function will be activated by request from other functional entities at call set-up/release. In the latter case, i.e. when the end-to-end connection has already been established, this function may also be invoked to cater for in-call service modification or at handover execution.

7.2.8 Load balancing

Load balancing has the task of handling uneven distribution of the traffic load over multiple cells. The purpose of load balancing is thus to influence the load distribution in such a manner that radio resources remain highly utilized and the

QoS of in-progress sessions is maintained to the greatest extent possible and call dropping probabilities are kept sufficiently small. Load balancing algorithms may result in handover or cell reselection decisions with the purpose of redistributing traffic from highly loaded cells to under-utilized cells.

7.2.9 Distribution function for NAS messages

In the RRC protocol and the S1AP, messages from the NAS shall be transparently transferred within the Access Stratum.

7.2.10 NAS node selection function

The interconnection of E-UTRAN to multiple MME / S-GWs is supported in the E-UTRAN architecture. Therefore a NAS node selection function is located in the E-UTRAN to determine the MME association of the UE, based on the UE's temporary identifier, which was assigned to the UE by the MME.

7.2.11 Synchronization

The network synchronization is to maintain the synchronization of the timing between different nodes within the network. As no single method can cover all E-UTRAN applications a logical port at eNB may be used for reception of timing input independent of synchronization method chosen.

7.2.12 Radio access network sharing

This function is to enable multiple PLMNs to share a radio access network. This function has mechanisms to direct the UE to the appropriate PLMN at the network sharing border and to restrict UE measurement and reselection to cells that are entitled to access. The E-UTRAN can broadcast multiple PLMN-IDs in the radio interface. The UE can choose one amongst the broadcasted PLMN-IDs.

An eNB is allowed to handover a UE to a target cell with multiple PLMN identities if at least one of the target cell PLMN identities is listed as allowed in the area restriction information for the UE, i.e. listed as Serving PLMN or an equivalent PLMN.

7.2.13 MBMS function

This function enables the E-UTRAN to transmit the same data to multiple recipients and allows network and radio resources to be shared.

The support of MBMS is out of scope of this Release.

7.2.14 Subscriber and equipment trace

Support for subscriber and equipment trace for LTE and EPS shall be as specified in 3GPP specifications 32.421, 32.422, 32.423 and 3GPP Trace IRP 32.441, 32.442 and 32.443.

All traces are initiated by the core network, even if the trace is to be carried out in the radio network.

A trace setup in the radio network will be propagated on the X2 interface at handover and on the S1 interface if the handover is carried out between MMEs.

7.2.15 RAN Information Management

The RAN Information Management (RIM) function is a generic mechanism that allows the request and transfer of information (e.g. GERAN System information) between two RAN nodes via the core network as described in [12] and [13].

7.2.16 Paging

This function provides the capability to request an UE to contact the E-UTRAN when UE is in ECM_IDLE state or to be addressed of incoming warning message (ETWS) when UE is in ECM_CONNECTED state.

8 Mobility management

8.1 Signalling connection

The UE may either have or not have a UE associated logical S1 connection:

- 1) When a UE associated logical S1 connection exists the EPC can reach the UE by the UE associated logical S1 connection on the EPC side, and the E-UTRAN has a context with the UE and EPC for this particular connection. This context is erased when the connection is released. The UE associated logical S1 connection can be initiated from the UE only.
- 2) When a UE associated logical S1 connection does not exist, the EPC must reach the UE via the common procedure. The message sent to the UE can be a request to the UE to establish a UE associated logical S1 connection. The UE is addressed with a user/terminal identity within a tracking area.

8.2 Consequences for mobility handling

In general, the radio access specific procedures should be handled within E-UTRAN. This means that all cell level mobility should be handled within E-UTRAN.

When there exists a dedicated connection to the UE, the E-UTRAN handles the radio interface mobility of the UE. This includes the Handover procedure in the ECM_CONNECTED state.

When a dedicated connection between the E-UTRAN and the UE does not exist, no UE context information is stored in E-UTRAN. Therefore, the mobility is handled directly between UE and EPC outside access stratum (e.g. by means of registration procedures). When paging the UE, the EPC indicates a 'geographical area' that is translated within E-UTRAN to the actual cells that shall be paged. A 'geographical area' could be a tracking area or a list of tracking areas.

Thus, the E-UTRAN does not contain any permanent 'location registers' for the UE, but only temporary UE contexts information for the duration of the dedicated connection.

9 Synchronization

9.1 eNB Synchronisation

The eNB shall support a logical synchronization port for phase-, time- and/or frequency synchronisation.

Logical synchronisation port for phase- and time-synchronisation shall provide

- 1) accuracy that allows to meet the eNB requirements on maximum relative phase difference for all eNBs in synchronised TDD-unicast area and FDD/TDD-multicast MBSFN synchronisation area;
- 1) continuous time without leap seconds traceable to common time reference for all eNBs in synchronised TDD-unicast area and FDD/TDD-multicast MBSFN synchronisation area;

Furthermore common SFN initialisation time shall be provided for all eNBs in synchronised TDD-unicast area and FDD/TDD-multicast MBSFN synchronisation area.

Based on this information, the eNB may derive the SFN according to the following formula

$$SFN = \{time\} \bmod \{period(SFN)\},$$

where

Time	time adjusted by the common SFN initialisation time, in units of 10ms to match the length of radio frame and accuracy accordingly;
period(SFN)	SFN period.

NOTE: When eNB is connected via TDM interfaces, these could be used to synchronize frequency the eNB. The characteristics of these interfaces are described in 25.411.

In case eNB is connected via TDM interface, it may be used to synchronize frequency the eNB. The characteristics of the clock in the eNB shall be designed taking into account that the jitter and wander performance requirements on the interface are in accordance with network limits for output wander at traffic interfaces of either Reference [7], [8] or network limits for the maximum output jitter and wander at any hierarchical interface of Reference [9], whichever is applicable.

In case eNB is connected via Ethernet interface and the network supports Synchronous Ethernet, the eNB may use this interface to get frequency synchronization. In this case the design of the eNB clock should be done considering the jitter and wander performance requirements on the interface are as specified for output jitter and wander at EEC interfaces of Reference [10], defined in section 9.2.1/G.8261. Further considerations on Synchronous Ethernet recommendations and architectural aspects are defined in clause 12.2.1 and Annex A of G.8261.

10 void

11 E-UTRAN interfaces

11.1 General protocol model for E-UTRAN interfaces

The general protocol model for E-UTRAN interfaces is depicted in figure 11.1-1, and described in detail in the following subclauses. The structure is based on the principle that the layers and planes are logically independent of each other. Therefore, as and when required, the standardization body can easily alter protocol stacks and planes to fit future requirements.

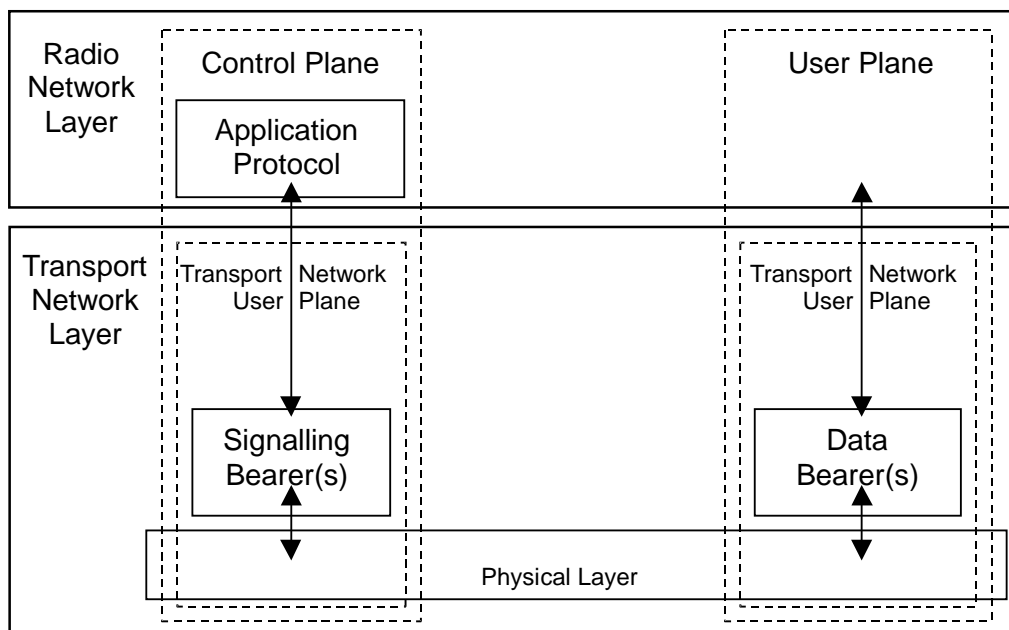

Figure 11.1-1: General protocol model for E-UTRAN interfaces

11.1.1 Radio Network Layer and Transport Network Layer

The protocol structure consists of two main layers, Radio Network Layer, and Transport Network Layer. E-UTRAN functions are realized in the Radio Network Layer, and the Transport Network Layer represents standard transport technology that is selected to be used for E-UTRAN.

11.1.2 Control plane

The control plane includes the Application Protocol, i.e. S1AP and X2AP and the Signalling Bearer for transporting the Application Protocol messages.

The Application Protocol is used e.g. for setting up bearers (i.e. E-RAB) in the Radio Network Layer. The bearer parameters in the Application Protocol are not directly tied to the User Plane technology, but are rather general bearer parameters.

11.1.3 User plane

The user plane includes the data bearer(s) for the data stream(s). The data stream(s) is characterized by a tunnelling protocol in the Transport Network Layer.

11.2 Iuant Interface - general principles

The Iuant interface for the control of RET antennas or TMAs is a logical part of the eNB.

Annex A (informative): Change History

TSG #	TSG Doc.	CR	Rev	Subject/Comment	New
2007-12	-	-	-	Specification approved at TSG-RAN 38 and placed under change control	8.0.0
39	RP-080079	0009	-	RAN3 agreed changes for TS 36.401	8.1.0
40	RP-080303	0011	1	RAN3 agreed changes for TS 36.401	8.2.0
41	RP-080582	0016		Uniqueness of eNB UE X2AP ID	8.3.0
41	RP-080582	0017	1	Completion of Cell and eNB identifiers	8.3.0
41	RP-080582	0019		Updating the Control Plane Protocol Stack	8.3.0
41	RP-080582	0020		Correction of the description of subscriber and equipment trace	8.3.0
42	RP-080844	0022		Clarify the relation between GUMMEI and MME UE S1AP ID	8.4.0
42	RP-080844	0023		Proposed way forward of FFS item in 36.401	8.4.0
42	RP-080844	0024	1	Adding the reference and correction on the GUMMEI definition reference	8.4.0
42	RP-080844	0025		Correction on the eNB UE Context descriptions	8.4.0
42	RP-080844	0026	1	RIM support in E-UTRAN	8.4.0
42	RP-080845	0027		Correction of SAE Bearer	8.4.0
42	RP-080844	0029		Correction of reference error	8.4.0
43	RP-090246	0031	1	GUMMEI usage for NNSF	8.5.0
43	RP-090245	0032		Measurement ID	8.5.0
43	RP-090089	0034		Description place for Paging Function	8.5.0
44	RP-090636	0035	1	Clarification on the Paging Function in E-UTRAN	8.6.0

History

Document history		
V8.2.0	November 2008	Publication
V8.3.0	November 2008	Publication
V8.4.0	January 2009	Publication
V8.5.0	April 2009	Publication
V8.6.0	July 2009	Publication