

ETSI TS 136 508 V8.3.0 (2009-10)

Technical Specification

**LTE;
Evolved Universal Terrestrial Radio Access (E-UTRA)
and Evolved Packet Core (EPC);
Common test environments for User Equipment (UE)
conformance testing
(3GPP TS 36.508 version 8.3.0 Release 8)**



ReferenceRTS/TSGR-0536508v830

KeywordsLTE

ETSI

650 Route des Lucioles
F-06921 Sophia Antipolis Cedex - FRANCE

Tel.: +33 4 92 94 42 00 Fax: +33 4 93 65 47 16

Siret N° 348 623 562 00017 - NAF 742 C
Association à but non lucratif enregistrée à la
Sous-Préfecture de Grasse (06) N° 7803/88

Important notice

Individual copies of the present document can be downloaded from:

<http://www.etsi.org>

The present document may be made available in more than one electronic version or in print. In any case of existing or perceived difference in contents between such versions, the reference version is the Portable Document Format (PDF). In case of dispute, the reference shall be the printing on ETSI printers of the PDF version kept on a specific network drive within ETSI Secretariat.

Users of the present document should be aware that the document may be subject to revision or change of status. Information on the current status of this and other ETSI documents is available at

<http://portal.etsi.org/tb/status/status.asp>

If you find errors in the present document, please send your comment to one of the following services:

http://portal.etsi.org/chaicor/ETSI_support.asp

Copyright Notification

No part may be reproduced except as authorized by written permission.
The copyright and the foregoing restriction extend to reproduction in all media.

© European Telecommunications Standards Institute 2009.
All rights reserved.

DECTTM, **PLUGTESTS**TM, **UMTS**TM, **TIPHON**TM, the TIPHON logo and the ETSI logo are Trade Marks of ETSI registered for the benefit of its Members.

3GPPTM is a Trade Mark of ETSI registered for the benefit of its Members and of the 3GPP Organizational Partners.

LTETM is a Trade Mark of ETSI currently being registered

for the benefit of its Members and of the 3GPP Organizational Partners.

GSM[®] and the GSM logo are Trade Marks registered and owned by the GSM Association.

Intellectual Property Rights

IPRs essential or potentially essential to the present document may have been declared to ETSI. The information pertaining to these essential IPRs, if any, is publicly available for **ETSI members and non-members**, and can be found in ETSI SR 000 314: *"Intellectual Property Rights (IPRs); Essential, or potentially Essential, IPRs notified to ETSI in respect of ETSI standards"*, which is available from the ETSI Secretariat. Latest updates are available on the ETSI Web server (<http://webapp.etsi.org/IPR/home.asp>).

Pursuant to the ETSI IPR Policy, no investigation, including IPR searches, has been carried out by ETSI. No guarantee can be given as to the existence of other IPRs not referenced in ETSI SR 000 314 (or the updates on the ETSI Web server) which are, or may be, or may become, essential to the present document.

Foreword

This Technical Specification (TS) has been produced by ETSI 3rd Generation Partnership Project (3GPP).

The present document may refer to technical specifications or reports using their 3GPP identities, UMTS identities or GSM identities. These should be interpreted as being references to the corresponding ETSI deliverables.

The cross reference between GSM, UMTS, 3GPP and ETSI identities can be found under <http://webapp.etsi.org/key/queryform.asp>.

Contents

Intellectual Property Rights	2
Foreword.....	2
Foreword.....	10
Introduction	10
1 Scope	11
2 References	11
3 Definitions, symbols and abbreviations	13
3.1 Definitions	13
3.2 Symbols.....	13
3.3 Abbreviations	13
4 Common test environment	14
4.1 Environmental conditions.....	14
4.1.1 Temperature.....	14
4.1.2 Voltage.....	14
4.2 Common requirements of test equipment.....	14
4.2.1 General functional requirements.....	15
4.2.2 Minimum functional requirements	15
4.2.2.1 Supported Cell Configuration	15
4.2.2.1.1 Supported Channels.....	16
4.2.2.2 Support of T_{cell} timing offset	17
4.3 Reference test conditions.....	17
4.3.1 Test frequencies	17
4.3.1.1 FDD Mode Test frequencies	17
4.3.1.1.1 FDD reference test frequencies for operating band 1	17
4.3.1.1.2 FDD reference test frequencies for operating band 2	18
4.3.1.1.3 FDD reference test frequencies for operating band 3	18
4.3.1.1.4 FDD reference test frequencies for operating band 4	18
4.3.1.1.5 FDD reference test frequencies for operating band 5	19
4.3.1.1.6 FDD reference test frequencies for operating band 6	19
4.3.1.1.7 FDD reference test frequencies for operating band 7	19
4.3.1.1.8 FDD reference test frequencies for operating band 8	20
4.3.1.1.9 FDD reference test frequencies for operating band 9	20
4.3.1.1.10 FDD reference test frequencies for operating band 10	20
4.3.1.1.11 FDD reference test frequencies for operating band 11	21
4.3.1.1.12 FDD reference test frequencies for operating band 12	21
4.3.1.1.13 FDD reference test frequencies for operating band 13	21
4.3.1.1.14 FDD reference test frequencies for operating band 14	22
4.3.1.1.15 FDD reference test frequencies for operating band 15	22
4.3.1.1.16 FDD reference test frequencies for operating band 16	22
4.3.1.1.17 FDD reference test frequencies for operating band 17	22
4.3.1.1.18 FDD reference test frequencies for operating band 18	22
4.3.1.1.19 FDD reference test frequencies for operating band 19	23
4.3.1.2 TDD Mode Test frequencies	23
4.3.1.2.1 TDD reference test frequencies for Operating Band 33	23
4.3.1.2.2 TDD reference test frequencies for Operating Band 34	23
4.3.1.2.3 TDD reference test frequencies for Operating Band 35	24
4.3.1.2.4 TDD reference test frequencies for Operating Band 36	24
4.3.1.2.5 TDD reference test frequencies for Operating Band 37	24
4.3.1.2.6 TDD reference test frequencies for Operating Band 38	25
4.3.1.2.7 TDD reference test frequencies for Operating Band 39	25
4.3.1.2.8 TDD reference test frequencies for Operating Band 40	25
4.3.2 Radio conditions	25
4.3.2.1 Normal propagation condition	25

4.3.3	Physical channel allocations	25
4.3.3.1	Antennas	25
4.3.3.2	Downlink physical channels and physical signals.....	26
4.3.3.3	Mapping of downlink physical channels and signals to physical resources.....	26
4.3.3.5	Mapping of uplink physical channels and signals to physical resources.....	28
4.3.4	Signal levels.....	29
4.3.4.1	Downlink signal levels.....	29
4.3.4.2	Uplink signal levels.....	29
4.3.5	Standard test signals.....	29
4.3.5.1	Downlink test signals	29
4.3.5.2	Uplink test signals	29
4.3.6	Physical layer parameters	30
4.3.6.1	Downlink physical layer parameters	30
4.3.6.1.1	Physical layer parameters for DCI format 0	30
4.3.6.1.2	Physical layer parameters for DCI format 1	31
4.3.6.1.3	Physical layer parameters for DCI format 1A	31
4.3.6.1.4	Physical layer parameters for DCI format 1C	32
4.3.6.1.5	Physical layer parameters for DCI format 2	32
4.3.6.1.6	Physical layer parameters for DCI format 2A	33
4.4	Reference system configurations.....	33
4.4.1	Simulated network scenarios	33
4.4.1.1	Single cell network scenarios	33
4.4.1.2	Intra E-UTRA multi cell network scenarios.....	34
4.4.1.3	Dual mode network scenarios	34
4.4.1.4	3GPP Inter-RAT network scenarios.....	34
4.4.1.5	3GPP2 Inter-RAT network scenarios.....	34
4.4.2	Simulated cells.....	34
4.4.3	Common parameters for simulated E-UTRA cells	36
4.4.3.1	Common configurations of system information blocks	36
4.4.3.1.1	Combinations of system information blocks	36
4.4.3.1.2	Scheduling of system information blocks.....	38
4.4.3.2	Common contents of system information messages	39
-	<i>MasterInformationBlock</i>	39
-	<i>SystemInformation</i>	40
-	<i>SystemInformationBlockType1</i>	41
4.4.3.3	Common contents of system information blocks	42
-	<i>SystemInformationBlockType2</i>	42
-	<i>SystemInformationBlockType3</i>	43
-	<i>SystemInformationBlockType4</i>	43
-	<i>SystemInformationBlockType5</i>	44
-	<i>SystemInformationBlockType6</i>	46
-	<i>SystemInformationBlockType7</i>	47
-	<i>SystemInformationBlockType8</i>	48
-	<i>SystemInformationBlockType9</i>	50
-	<i>SystemInformationBlockType10</i>	50
-	<i>SystemInformationBlockType11</i>	51
4.4.3.4	Channel-bandwidth-dependent parameters in system information blocks	51
4.4.4	Common parameters for simulated UTRA cells.....	51
4.4.4.1	Common contents of system information blocks for UTRA cells	52
-	System Information Block type 19.....	52
4.4.4.2	UTRA SIB scheduling for inter EUTRA - UTRA test.....	52
4.4.4.3	UTRA SIB scheduling for inter EUTRA - UTRA - GERAN test.....	53
4.4.5	Common parameters for simulated GERAN cells	54
4.4.6	Common parameters for simulated CDMA2000 cells.....	54
4.4.7	Default parameters specific for simulated cells	54
4.5	Generic procedures.....	54
4.5.1	UE test states.....	55
4.5.2	UE Registration (State 2).....	56
4.5.2.1	Initial conditions	56
4.5.2.2	Definition of system information messages	56
4.5.2.3	Procedure	57
4.5.2.4	Specific message contents.....	58

4.5.2A	UE Registration, UE Test Mode Activated (State 2A)	58
4.5.2A.1	Initial conditions	58
4.5.2A.2	Definition of system information messages	58
4.5.2A.3	Procedure	59
4.5.2A.4	Specific message contents	59
4.5.3	Generic Radio Bearer Establishment (State 3).....	60
4.5.3.1	Initial conditions	60
4.5.3.2	Definition of system information messages	60
4.5.3.3	Procedure	61
4.5.3.4	Specific message contents	62
4.5.3A	Generic Radio Bearer Establishment, UE Test Mode Activated (State 3A).....	62
4.5.3A.1	Initial conditions	62
4.5.3A.2	Definition of system information messages	62
4.5.3A.3	Procedure	63
4.5.3A.4	Specific message contents	63
4.5.4	Loopback Activation (State 4).....	63
4.5.4.1	Initial conditions	63
4.5.4.2	Definition of system information messages	63
4.5.4.3	Procedure	63
4.5.4.4	Specific message contents	63
4.6	Default RRC message and information elements contents	63
4.6.1	Contents of RRC messages	64
-	<i>CounterCheck</i>	64
-	<i>CounterCheckResponse</i>	64
-	<i>CSFBParametersRequestCDMA2000</i>	64
-	<i>CSFBParametersResponseCDMA2000</i>	65
-	<i>DLInformationTransfer</i>	65
-	<i>HandoverFromEUTRAPreparationRequest</i>	66
-	<i>MeasurementReport</i>	66
-	<i>MobilityFromEUTRACommand</i>	67
-	<i>Paging</i>	67
-	<i>RRCCConnectionReconfiguration</i>	68
-	<i>RRCCConnectionReconfigurationComplete</i>	69
-	<i>RRCCConnectionReestablishment</i>	69
-	<i>RRCCConnectionReestablishmentComplete</i>	69
-	<i>RRCCConnectionReestablishmentReject</i>	70
-	<i>RRCCConnectionReestablishmentRequest</i>	70
-	<i>RRCCConnectionReject</i>	70
-	<i>RRCCConnectionRelease</i>	71
-	<i>RRCCConnectionRequest</i>	71
-	<i>RRCCConnectionSetup</i>	71
-	<i>RRCCConnectionSetupComplete</i>	72
-	<i>SecurityModeCommand</i>	72
-	<i>SecurityModeComplete</i>	72
-	<i>SecurityModeFailure</i>	73
-	<i>UECapabilityEnquiry</i>	73
-	<i>UECapabilityInformation</i>	73
-	<i>ULHandoverPreparationTransfer</i>	74
-	<i>ULInformationTransfer</i>	74
4.6.2	System information blocks	74
4.6.3	Radio resource control information elements	75
-	BCCH-Config-DEFAULT	75
-	CQI-ReportConfig-DEFAULT	75
-	DRB-ToAddModList-RECONFIG	76
-	PCCH-Config-DEFAULT	76
-	PDCP-Config-RECONFIG-AM	76
-	PDCP-Config-RECONFIG-UM	76
-	PHICH-Config-DEFAULT	77
-	PDSCH-ConfigCommon-DEFAULT	77
-	PDSCH-ConfigDedicated-DEFAULT	77
-	PRACH-Config-DEFAULT	78
-	PRACH-ConfigSIB-DEFAULT	78

-	PUCCH-ConfigCommon-DEFAULT	79
-	PUCCH-ConfigDedicated-DEFAULT	79
-	PUSCH-ConfigCommon-DEFAULT	80
-	PUSCH-ConfigDedicated-DEFAULT	80
-	RACH-ConfigCommon-DEFAULT	81
-	RadioResourceConfigCommon-DEFAULT	82
-	RadioResourceConfigCommonSIB-DEFAULT	82
-	RadioResourceConfigDedicated-SRB1	83
-	RadioResourceConfigDedicated-SRB2-DRB(n,m)	84
-	RadioResourceConfigDedicated-DRB(n,m)	85
-	RadioResourceConfigDedicated-SRB1-SRB2-DRB(n,m)	86
-	RadioResourceConfigDedicated-HO	87
-	RLC-Config-DRB-AM-RECONFIG	87
-	RLC-Config-DRB-UM-RECONFIG	87
-	RLC-Config-SRB-AM-RECONFIG	88
-	SchedulingRequest-Config-DEFAULT	88
-	SoundingRS-UL-ConfigCommon-DEFAULT	89
-	SoundingRS-UL-ConfigDedicated-DEFAULT	89
-	SRB-ToAddModList-RECONFIG	90
-	TDD-Config-DEFAULT	90
-	TPC-PDCCH-Config-DEFAULT	90
-	UplinkPowerControlCommon-DEFAULT	91
-	UplinkPowerControlDedicated-DEFAULT	91
4.6.4	Security control information elements	92
-	SecurityConfigHO-DEFAULT	92
-	SecurityConfigSMC-DEFAULT	92
4.6.5	Mobility control information elements	93
-	MobilityControlInfo-HO	93
4.6.6	Measurement information elements	93
-	MeasConfig-DEFAULT	93
-	MeasGapConfig-GP1	94
-	MeasGapConfig-GP2	94
-	MeasObjectCDMA2000-GENERIC	95
-	MeasObjectEUTRA-GENERIC	95
-	MeasObjectGERAN-GENERIC	96
-	MeasObjectUTRA-GENERIC	96
-	QuantityConfig-DEFAULT	97
-	ReportConfigEUTRA-A1	97
-	ReportConfigEUTRA-A2	98
-	ReportConfigEUTRA-A3	98
-	ReportConfigEUTRA-PERIODICAL	99
-	ReportConfigInterRAT-B1-GERAN	99
-	ReportConfigInterRAT-B1-UTRA	100
-	ReportConfigInterRAT-B2-CDMA2000	101
-	Table 4.6.6-7D: void-ReportConfigInterRAT-B2-GERAN	102
-	ReportConfigInterRAT-B2-UTRA	103
-	ReportConfigInterRAT-PERIODICAL	103
4.6.7	Other information elements	104
-	RRC-TransactionIdentifier-DL	104
-	RRC-TransactionIdentifier-UL	104
4.6.8	Channel-bandwidth-dependent parameters	104
4.7	Default NAS message and information element contents	104
4.7.1	Security protected NAS messages	105
4.7.2	Contents of EMM messages	106
-	ATTACH ACCEPT	106
-	ATTACH COMPLETE	108
-	ATTACH REJECT	108
-	ATTACH REQUEST	109
-	AUTHENTICATION FAILURE	110
-	AUTHENTICATION REJECT	110
-	AUTHENTICATION REQUEST	111
-	AUTHENTICATION RESPONSE	111

-	CS SERVICE NOTIFICATION	112
-	DETACH ACCEPT (UE originating detach).....	112
-	DETACH ACCEPT (UE terminated detach).....	112
-	DETACH REQUEST (UE originating detach).....	113
-	DETACH REQUEST (UE terminated detach)	113
-	DOWNLINK NAS TRANSPORT.....	114
-	EMM INFORMATION	114
-	EMM STATUS	115
-	EXTENDED SERVICE REQUEST	115
-	GUTI REALLOCATION COMMAND	116
-	GUTI REALLOCATION COMPLETE	116
-	IDENTITY REQUEST	116
-	IDENTITY RESPONSE	117
-	SECURITY MODE COMMAND	117
-	SECURITY MODE COMPLETE	118
-	SECURITY MODE REJECT	118
-	SERVICE REJECT	118
-	SERVICE REQUEST	119
-	TRACKING AREA UPDATE ACCEPT	120
-	TRACKING AREA UPDATE COMPLETE.....	121
-	TRACKING AREA UPDATE REJECT	122
-	TRACKING AREA UPDATE REQUEST.....	123
-	UPLINK NAS TRANSPORT	124
4.7.3	Contents of ESM messages.....	124
-	ACTIVATE DEDICATED EPS BEARER CONTEXT ACCEPT	124
-	ACTIVATE DEDICATED EPS BEARER CONTEXT REJECT	125
-	ACTIVATE DEDICATED EPS BEARER CONTEXT REQUEST	126
-	ACTIVATE DEFAULT EPS BEARER CONTEXT ACCEPT	127
-	ACTIVATE DEFAULT EPS BEARER CONTEXT REJECT	127
-	ACTIVATE DEFAULT EPS BEARER CONTEXT REQUEST.....	128
-	BEARER RESOURCE ALLOCATION REJECT	129
-	BEARER RESOURCE ALLOCATION REQUEST.....	130
-	BEARER RESOURCE MODIFICATION REJECT	130
-	BEARER RESOURCE MODIFICATION REQUEST	131
-	DEACTIVATE EPS BEARER CONTEXT ACCEPT	132
-	DEACTIVATE EPS BEARER CONTEXT REQUEST.....	132
-	ESM INFORMATION REQUEST.....	133
-	ESM INFORMATION RESPONSE.....	133
-	ESM STATUS	134
-	MODIFY EPS BEARER CONTEXT ACCEPT.....	134
-	MODIFY EPS BEARER CONTEXT REJECT	135
-	MODIFY EPS BEARER CONTEXT REQUEST	136
-	PDN CONNECTIVITY REJECT	137
-	PDN CONNECTIVITY REQUEST	138
-	PDN DISCONNECT REJECT	138
-	PDN DISCONNECT REQUEST.....	139
4.7A	Default TC message and information element contents	139
-	ACTIVATE TEST MODE	139
-	ACTIVATE TEST MODE COMPLETE.....	140
-	CLOSE UE TEST LOOP.....	140
-	CLOSE UE TEST LOOP COMPLETE.....	140
-	DEACTIVATE TEST MODE	141
-	DEACTIVATE TEST MODE COMPLETE	141
-	OPEN UE TEST LOOP	141
-	OPEN UE TEST LOOP COMPLETE	141
4.8	Reference radio bearer configurations.....	142
4.8.1	General.....	142
4.8.2	SRB and DRB parameters and combinations	142
4.8.2.1	SRB and DRB parameters.....	142
4.8.2.1.1	SRB configurations	142
4.8.2.1.2	DRB PDCP configurations.....	142
4.8.2.1.3	DRB RLC configurations	143

4.8.2.1.4	DRB Logical Channel configurations	144
4.8.2.1.5	MAC configurations	145
4.8.2.1.6	Physical Layer configurations	147
4.8.2.1.7	DRB configurations.....	148
4.8.2.2	SRB and DRB combinations.....	148
4.8.2.2.1	Combinations on DL-SCH and UL-SCH	148
4.8.3	UTRA reference radio parameters and combinations	148
4.8.4	GERAN reference PDP context parameters	148
4.9	Common test USIM parameters	149
4.9.1	General.....	149
4.9.1.1	Definitions.....	149
4.9.1.2	Definition of the test algorithm for authentication.....	149
4.9.1.2.1	Authentication and key derivation in the test USIM and SS	149
4.9.1.2.2	Generation of re-synchronization parameters in the USIM.....	149
4.9.1.2.3	Using the authentication test algorithm for UE conformance testing.....	149
4.9.2	Default parameters for the test USIM	149
4.9.3	Default settings for the Elementary Files (EFs).....	149
5	Test environment for RF test.....	151
5.1	Requirements of <i>test</i> equipment	151
5.2	RF/RRM Reference system configurations	151
5.2.1	Common parameters for simulated E-UTRA cells	151
5.2.1.1	Combinations of system information blocks.....	151
5.2.1.2	Scheduling of system information blocks	151
5.2.1.2	Common contents of system information messages	152
-	<i>MasterInformationBlock</i>	152
-	<i>SystemInformation</i>	152
-	<i>SystemInformationBlockType1</i>	152
5.3	Default RRC message and information elements contents.....	152
5.4	Default NAS message and information elements contents.....	153
5.5	Reference radio bearer configurations.....	153
5.5.1	SRB and DRB parameters	153
5.5.1.1	Physical Layer configurations.....	153
6	Test environment for Signalling test	154
6.1	Requirements of test equipment	154
6.2	Reference test conditions.....	154
6.2.1	Physical channel allocations	154
6.2.1.1	Antennas	154
6.2.1.2	Downlink physical channels and physical signals.....	154
6.2.1.3	Mapping of downlink physical channels and signals to physical resources.....	154
6.2.1.4	Uplink physical channels and physical signals	155
6.2.1.5	Mapping of uplink physical channels and signals to physical resources.....	155
6.2.2	Signal levels.....	155
6.2.2.1	Downlink signal levels.....	155
6.2.2.2	Measurement accuracy and side conditions	155
6.3	Reference system configurations.....	156
6.3.1	Default parameter specific for simulated cells.....	157
6.3.1.1	Intra-frequency neighbouring cell list in SIB4 for E-UTRA cells	157
6.3.1.2	Inter-frequency carrier frequency list in SIB5 for E-UTRA cells	157
6.3.1.3	UTRA carrier frequency list in SIB6 for E-UTRA cells.....	157
6.3.1.4	GERAN carrier frequency group list in SIB7 for E-UTRA cells.....	158
6.3.1.5	CDMA2000 HRPD carrier frequency list in SIB8 for E-UTRA cells	158
6.3.1.6	CDMA2000 1xRTT carrier frequency list in SIB8 for E-UTRA cells	159
6.3.1.7	E-UTRA carrier frequency list in SIB19 for UTRA cells	159
6.3.2	Default configurations for NAS test cases.....	159
6.3.2.1	Simulated network scenarios for NAS test cases	159
6.3.2.2	Simulated NAS cells	159
6.3.2.3	Broadcast system information.....	161
6.3.2.3.1	Intra-frequency neighbouring cell list in SIB4 for E-UTRA NAS cells.....	161
6.3.2.3.2	Inter-frequency carrier frequency list in SIB5 for E-UTRA NAS cells.....	161
6.3.3	Cell configurations.....	161

6.3.3.1	Full cell configuration	161
6.3.3.2	Minimum uplink cell configuration	162
6.3.3.3	Broadcast only cell configuration	162
6.3.3.4	Application of different cell configurations	162
6.4	Generic procedures	162
6.4.1	Initial UE states and setup procedures	163
6.4.1.1	Initial UE states and setup procedures	163
6.4.1.2	Dedicated Bearer Establishment (to state 5)	163
6.4.1.2.1	Initial conditions	163
6.4.1.2.2	Definition of system information messages.....	163
6.4.1.2.3	Procedure.....	164
6.4.1.2.4	Specific message contents	164
6.4.1.3	Loopback Activation (to state 6).....	164
6.4.1.3.1	Initial conditions	164
6.4.1.3.2	Definition of system information messages.....	164
6.4.1.3.3	Procedure.....	164
6.4.1.3.4	Specific message contents	165
6.4.2	Test procedures	165
6.4.2.1	Introduction	165
6.4.2.2	Test procedure to check RRC_IDLE state	165
6.4.2.3	Test procedure to check RRC_CONNECTED state	166
6.4.2.4	Test procedure Paging (for NAS testing).....	166
6.4.2.5	Test procedure for no response to paging (for NAS testing).....	166
6.4.2.6	Test procedure to check that a dedicated EPS bearer context is active (for NAS testing)	166
6.4.2.7	Test procedure to check that UE is camped on a new E-UTRAN cell.....	167
6.4.2.8	Test procedure to check that UE is camped on a new UTRAN cell.....	167
6.4.2.9	Test procedure to check that UE is camped on a new GERAN cell.....	168
6.5	Default RRC message and information element contents	169
6.6	Default NAS message and information element contents	169
6.6.1	Reference default EPS bearer contexts	169
6.6.2	Reference dedicated EPS bearer contexts	170
6.7	Timer Tolerances.....	171
Annex A (informative):	Connection Diagrams	173
Annex B (informative):	Change history	184
History		188

Foreword

This Technical Specification has been produced by the 3rd Generation Partnership Project (3GPP).

The contents of the present document are subject to continuing work within the TSG and may change following formal TSG approval. Should the TSG modify the contents of the present document, it will be re-released by the TSG with an identifying change of release date and an increase in version number as follows:

Version x.y.z

where:

- x the first digit:
 - 1 presented to TSG for information;
 - 2 presented to TSG for approval;
 - 3 or greater indicates TSG approved document under change control.
- y the second digit is incremented for all changes of substance, i.e. technical enhancements, corrections, updates, etc.
- z the third digit is incremented when editorial only changes have been incorporated in the document.

Introduction

The definition of the Conformance Tests for UE in E-UTRAN will be a complex task as the complete test suite covers RF, EMC and Protocol aspects of the UE.

Each test requires a Test Environment to be defined in which the UE has to operate to defined standards, constraints and performance. The overall task can be simplified if there are a number of well defined and agreed Common Test Environments where every one can be used for a number of tests. Hence the present document defines testing conditions that are common to several tests avoiding the need to duplicate the same information for every single test.

The present document defines default values for a variety of common areas. Where values are not specified in test cases, the defaults in the present document will apply. If specified, the test case values will take precedence.

1 Scope

The present document contains definitions of reference conditions and test signals, default parameters, reference radio bearer configurations used in radio bearer interoperability testing, common radio bearer configurations for other test purposes, common requirements for test equipment and generic set-up procedures for use in conformance tests for the 3rd Generation E-UTRAN User Equipment (UE).

2 References

The following documents contain provisions which, through reference in this text, constitute provisions of the present document.

- References are either specific (identified by date of publication, edition number, version number, etc.) or non-specific.
- For a specific reference, subsequent revisions do not apply.
- For a non-specific reference, the latest version applies. In the case of a reference to a 3GPP document (including a GSM document), a non-specific reference implicitly refers to the latest version of that document in the same Release as the present document.

- [1] 3GPP TR 21.905: "Vocabulary for 3GPP Specifications".
- [2] 3GPP TS 23.003: "Numbering, addressing and identification".
- [3] 3GPP TS 23.122: "Non-Access-Stratum functions related to Mobile Station (MS) in idle mode".
- [4] 3GPP TS 24.008: "Mobile radio interface Layer 3 specification; Core network protocols; Stage 3".
- [5] 3GPP TS 34.108: "Common Test Environments for User Equipment (UE); Conformance testing".
- [6] 3GPP TS 34.109: "Terminal logical test interface; Special conformance testing functions".
- [7] 3GPP TS 34.123-1: "User Equipment (UE) conformance specification; Part 1: Protocol conformance specification".
- [8] 3GPP TS 34.123-2: "User Equipment (UE) conformance specification; Part 2: Implementation conformance statement (ICS) specification".
- [9] 3GPP TS 34.123-3: "User Equipment (UE) conformance specification; Part 3: Abstract test suites (ATs)".
- [10] 3GPP TS 36.300: "Evolved Universal Terrestrial Radio Access (E-UTRA) and Evolved Universal Terrestrial Radio Access Network (E-UTRAN); Overall description; Stage 2".
- [11] 3GPP TS 36.302: "Evolved Universal Terrestrial Radio Access (E-UTRA); Services provided by the physical layer".
- [12] 3GPP TS 36.304: "Evolved Universal Terrestrial Radio Access (E-UTRA); User Equipment (UE) procedures in idle mode".
- [13] 3GPP TS 36.306: "Evolved Universal Terrestrial Radio Access (E-UTRA); User Equipment (UE) radio access capabilities".
- [14] 3GPP TS 36.321: "Evolved Universal Terrestrial Radio Access (E-UTRA); Medium Access Control (MAC) protocol specification".
- [15] 3GPP TS 36.322: "Evolved Universal Terrestrial Radio Access (E-UTRA); Radio Link Control (RLC) protocol specification".

- [16] 3GPP TS 36.323: "Evolved Universal Terrestrial Radio Access (E-UTRA); Packet Data Convergence Protocol (PDCP) specification".
- [17] 3GPP TS 36.331: "Evolved Universal Terrestrial Radio Access (E-UTRA); Radio Resource Control (RRC); Protocol Specification".
- [18] 3GPP TS 36.523-1: "Evolved Universal Terrestrial Radio Access (E-UTRA) and Evolved Packet Core (EPC); User Equipment (UE) conformance specification; Part 1: Protocol conformance specification".
- [19] 3GPP TS 36.523-2: "Evolved Universal Terrestrial Radio Access (E-UTRA) and Evolved Packet Core (EPC); User Equipment (UE) conformance specification; Part 2: Implementation Conformance Statement (ICS) proforma specification".
- [20] 3GPP TS 36.523-3: "Evolved Universal Terrestrial Radio Access (E-UTRA) and Evolved Packet Core (EPC); User Equipment (UE) conformance specification; Part 3: Abstract Test Suites (ATS)".
- [21] 3GPP TS 36.521-1: "Evolved Universal Terrestrial Radio Access (E-UTRA); User Equipment (UE) conformance specification; Radio transmission and reception; Part 1: conformance testing".
- [22] 3GPP TS 36.521-2: "Evolved Universal Terrestrial Radio Access (E-UTRA); User Equipment (UE) conformance specification; Radio transmission and reception; Part 2: Implementation Conformance Statement (ICS)".
- [23] 3GPP TR 24.801: "3GPP System Architecture Evolution; CT WG1 aspects".
- [24] 3GPP TS 23.401: "General Packet Radio Service(GPRS) enhancements for Evolved Universal Terrestrial Access Network (E-UTRAN) access".
- [25] 3GPP TS 51.010-1: "Mobile Station (MS) conformance specification; Part 1: Conformance specification".
- [26] ISO/IEC 9646 (all parts): "Information technology - Open Systems Interconnection - Conformance testing methodology and framework".
- [27] 3GPP TS 36.101: "Evolved Universal Terrestrial Radio Access (E-UTRA); User Equipment (UE) radio transmission and reception".
- [28] 3GPP TS 24.301: "Non-Access-Stratum (NAS) protocol for Evolved Packet System (EPS); Stage 3".
- [29] 3GPP TS 36.213: "Evolved Universal Terrestrial Radio Access (E-UTRA); Physical layer procedures".
- [30] 3GPP TS 36.104: "Evolved Universal Terrestrial Radio Access (E-UTRA); Base Station (BS) radio transmission and reception".
- [31] 3GPP TS 33.401: "3GPP System Architecture Evolution (SAE); Security architecture".
- [32] 3GPP TS 31.101: "UICC-terminal interface; Physical and logical characteristics".
- [33] 3GPP TS 31.102: "Characteristics of the Universal Subscriber Identity Module (USIM) application".
- [34] 3GPP TS 36.521-3: "Evolved Universal Terrestrial Radio Access (E-UTRA); User Equipment (UE) conformance specification; Radio transmission and reception; Part 3: Radio Resource Management conformance testing".
- [35] 3GPP TS 36.211: "Evolved Universal Terrestrial Radio Access (E-UTRA); Physical channels and modulation".
- [36] 3GPP2 TSG-C C.S0038-A v2.0: "Signaling Conformance Specification for High Rate Packet Data Air Interface".

- [37] 3GPP2 TSG-C C.S0043-0 v1.0: "Signaling Conformance Test Specification for cdma2000 Spread Spectrum Systems".
- [38] 3GPP TS 36.509: "Evolved Universal Terrestrial Radio Access (E-UTRA); Special conformance testing functions for User Equipment (UE)"
- [39] 3GPP TS 36.133: "Evolved Universal Terrestrial Radio Access (E-UTRA); Requirements for support of radio resource management"

3 Definitions, symbols and abbreviations

3.1 Definitions

For the purposes of the present document, the terms and definitions given in TR 21.905 [1] apply, unless specified below:

B: a value followed by "B" is a binary value.

H: a value followed by "H" is a hexadecimal value.

3.2 Symbols

For the purposes of the present document, the following symbols apply:

N_{DL}	Downlink EARFCN
N_{UL}	Uplink EARFCN

3.3 Abbreviations

For the purposes of the present document, the abbreviations specified in TR 21.905 [1] apply, with any additional abbreviations specified below:

1xRTT	1x Radio Transmission Technology
DRB	(user) Data Radio Bearer
EARFCN	E-UTRA Absolute Radio Frequency Channel Number
ECM	EPS Connection Management
EMM	EPS Mobility Management
ENB	Evolved Node B
EPRE	Energy Per Resource Element
ESM	EPS Session Management
HRPD	High Rate Packet Data
MAC	Media Access Control
OFDM	Orthogonal Frequency Division Multiplexing
RBs	Resource Blocks
ROHC	Robust Header Compression
SS	System Simulator
TH	Temperature High
TL	Temperature Low
VH	Higher extreme Voltage
VL	Lower extreme Voltage
xCH_RA	xCH -to-RS EPRE ratio for the channel xCH in all transmitted OFDM symbols not containing RS
xCH_RB	xCH -to-RS EPRE ratio for the channel xCH in all transmitted OFDM symbols containing RS

4 Common test environment

4.1 Environmental conditions

The requirements in this clause apply to all types of UE(s).

4.1.1 Temperature

The UE shall fulfil all the requirements in the full temperature range of:

Table 4.1.1-1: Temperature Test Environment

+15°C to +35°C	for normal conditions (with relative humidity of 25 % to 75 %)
-10°C to +55°C	for extreme conditions (see IEC publications 68-2-1 and 68-2-2)

Outside this temperature range the UE, if powered on, shall not make ineffective use of the radio frequency spectrum. In no case shall the UE exceed the transmitted levels as defined in TS 36.101 [27] for extreme operation.

The normative reference for this requirement is TS 36.101 [27] Annex E.1.

Some tests are performed also in extreme temperature conditions. These test conditions are denoted as TL (temperature low, -10°C) and TH (temperature high, +55°C).

4.1.2 Voltage

The UE shall fulfil all the requirements in the full voltage range, i.e. the voltage range between the extreme voltages.

The manufacturer shall declare the lower and higher extreme voltages and the approximate shutdown voltage. For the equipment that can be operated from one or more of the power sources listed below, the lower extreme voltage shall not be higher, and the higher extreme voltage shall not be lower than that specified below.

Table 4.1.2-1: Voltage Test Environment

Power source	Lower extreme voltage	Higher extreme voltage	Normal conditions voltage
AC mains	0,9 * nominal	1,1 * nominal	nominal
Regulated lead acid battery	0,9 * nominal	1,3 * nominal	1,1 * nominal
Non regulated batteries:			
Leclanché	0,85 * nominal	Nominal	Nominal
Lithium	0,95 * nominal	1,1 * Nominal	1,1 * Nominal
Mercury/nickel & cadmium	0,90 * nominal		Nominal

Outside this voltage range the UE if powered on, shall not make ineffective use of the radio frequency spectrum. In no case shall the UE exceed the transmitted levels as defined in TS 36.101 [27] for extreme operation. In particular, the UE shall inhibit all RF transmissions when the power supply voltage is below the manufacturer declared shutdown voltage.

The normative reference for this requirement is TS 36.101 [27] Annex E.2.

Some tests are performed also in extreme voltage conditions. These test conditions are denoted as VL (lower extreme voltage) and VH (higher extreme voltage).

4.2 Common requirements of test equipment

Mobile conformance testing can be categorized into 3 distinct areas:

- RF Conformance Testing.

- EMC Conformance Testing.
- Signalling Conformance Testing.

The test equipment required for each category of testing may or not be different, depending on the supplier of the test equipment. However, there will be some generic requirements of the test equipment that are essential for all three categories of test, and these are specified in this clause.

In addition, there will be requirements to test operation in multi-system configurations (e.g. EUTRAN plus UTRAN). However, these would not form a common test equipment requirement for the three test areas and are not considered in the present document.

4.2.1 General functional requirements

NOTE: This clause has been written such that it does not constrain the implementation of different architectures and designs of test equipment.

All test equipment used to perform conformance testing on a UE shall provide a platform suitable for testing UE's that are either:

- a) FDD Mode; or
- b) TDD Mode; or
- c) both FDD/TDD Modes.

All test equipment shall provide (for the mode(s) supported) the following minimum functionality.

- The capability of emulating a single E-UTRA cell with the appropriate channels to allow the UE to register on the cell.
- The capability to allow the UE to set up an RRC connection with the system simulator, and to maintain the connection for the duration of the test.
- The capability (for the specific test):
 - to select and support an appropriate radio bearer for the downlink;
 - to set the appropriate downlink power levels;
 - to set up and support the appropriate radio bearer for the uplink;
 - to set and control the uplink power levels.

4.2.2 Minimum functional requirements

4.2.2.1 Supported Cell Configuration

The System Simulator shall provide the capability to simulate a minimum number of cells (of the appropriate E-UTRA Mode) whose number and capabilities are governed by the test cases that need to be performed (test cases are defined in 3GPP TS 36.523-1 [18](Signalling), 3GPP TS 36.521-1 [21] (RF) and 3GPP TS 36.521-3 [tbd] (RRM). For this purpose test cases can be split into two different categories: Tests that require only one cell and Tests that require several cells.

To perform test cases requiring one cell, the system simulator must provide a cell offering the capabilities to perform all the test cases in this category.

To perform test cases requiring several cells, additional cells must be provided by the system simulator. The additional cells, however, need only provide a minimum set of capabilities so as to support the first cell in carrying out the multi-cell test cases.

The type and number of channels (especially physical channels) constitute an important set of capabilities for a cell. The following clauses list possible channels that may be supported by the SS. Each channel type, however, and the minimum number of channels needed are only mandatory if specific test cases require them.

The mapping between Logical and Transport channels is as described in 3GPP TS 36.321 [14]. Similarly the mapping between Transport channels and Physical channels is as described in 3GPP TS 36.211, TS 36.302 and TS 36.212. The reference measurement channels (mapping between Transport channels and Physical channels for PDSCH/PDCCH) are defined in 3GPP TS 36.521-1[21] annex A

4.2.2.1.1 Supported Channels

4.2.2.1.1.1 Logical channels

Logical channel	Minimum number	Comments
BCCH	1	
CCCH	1	
DCCH	2	
PCCH	1	
DTCH	n <FFS>	Depending on SS's support for RB service testing (See clause 12 of 3GPP TS 36.523-1 [?])

4.2.2.1.1.2 Transport channels

Transport channel	Minimum number	Comments
BCH	1	
PCH	1	
RACH	1	
DL-SCH	n <FFS>	
UL-SCH	n <FFS>	

4.2.2.1.1.3 Physical channels

Physical channel	Minimum number	Comments
PBCH	1	Physical Broadcast Channel
PCFICH	1	The physical control format indicator channel carries information about the number of OFDM symbols used for transmission of PDCCHs in a subframe
PDCCH	1	The physical downlink control channel carries scheduling assignments and other control information.
PDSCH	1	Physical Downlink Shared Channel
PHICH	[1]	The PHICH carries the hybrid-ARQ ACK/NAK
PUCCH	1	The physical uplink control channel carries uplink control information
PUSCH	1	Physical Uplink Shared Channel
PRACH	1	Physical Random Access Channel

4.2.2.1.1.4 Physical signals

Physical signal	Minimum number	Comments
Demodulation reference signal	NA	UL
Sounding Reference signal	NA	UL TBD, if applicable
Cell-specific Reference Signal	NA	DL
UE-specific reference signal	NA	DL
Primary synchronisation signal	NA	DL
Secondary synchronisation signal	NA	DL

4.2.2.2 Support of T_{cell} timing offset

The timing offset in terms of frame start timing between any pair of TDD cells shall be $< [3\mu\text{s}]$. For FDD cells there is no such restriction.

4.3 Reference test conditions

This clause contains the reference test conditions, which apply to all test cases unless otherwise specified.

4.3.1 Test frequencies

The test frequencies are based on the E-UTRA frequency bands defined in the core specifications.

The raster spacing is 100 KHz.

E-UTRA/FDD is designed to operate in paired bands of 3GPP TS 36.101 [27]. The reference test frequencies for the RF and Signalling test environment for each of the 14 operating bands are defined in sub clause 4.3.1.1.

E-UTRA/TDD is designed to operate in unpaired bands of 3GPP TS 36.101 [27]. The reference test frequencies for the RF and Signalling test environment for each of the 8 operating bands are defined in sub clause 4.3.1.2.

NOTE: For Signalling testing, E-UTRA frequency to be tested is mid range and E-UTRA channel bandwidth to be tested is 5MHz for all operating bands for all test cases as the default configuration.

NOTE: For RF testing, E-UTRA frequencies to be tested are low range, mid range and high range for all supported operating bands by default. E-UTRA channel bandwidths to be tested are lowest bandwidth, 5MHz bandwidth and highest bandwidth for all supported operating bands by default. Actual test configurations are specified case by case and stated in test case itself as the initial conditions.

NOTE: The lowest bandwidth, 5MHz bandwidth and highest bandwidth are selected from the combined table which includes nominal and additional channel bandwidth.

NOTE: In the case 5MHz bandwidth is not supported by the UE, E-UTRA channel bandwidth to be tested are only lowest bandwidth and highest bandwidth.

NOTE: If channel bandwidth to be tested is equal to the lowest or highest channel bandwidth, then the same channel bandwidth is not required to be tested twice.

4.3.1.1 FDD Mode Test frequencies

4.3.1.1.1 FDD reference test frequencies for operating band 1

Table 4.3.1.1.1-1: Test frequencies for E-UTRA channel bandwidth for operating band 1

Test Frequency ID	Bandwidth [MHz]	N_{UL}	Frequency of Uplink [MHz]	N_{DL}	Frequency of Downlink [MHz]
Low Range	5	18025	1922.5	25	2112.5
	10	18050	1925	50	2115
	15	18075	1927.5	75	2117.5
	20	18100	1930	100	2120
Mid Range	5/10/15/20	18300	1950	300	2140
High Range	5	18575	1977.5	575	2167.5
	10	18550	1975	550	2165
	15	18525	1972.5	525	2162.5
	20	18500	1970	500	2160

4.3.1.1.2 FDD reference test frequencies for operating band 2

Table 4.3.1.1.2-1: Test frequencies for E-UTRA channel bandwidth for operating band 2

Test Frequency ID	Bandwidth [MHz]	N _{UL}	Frequency of Uplink [MHz]	N _{DL}	Frequency of Downlink [MHz]
Low Range	1.4	18607	1850.7	607	1930.7
	3	18615	1851.5	615	1931.5
	5	18625	1852.5	625	1932.5
	10	18650	1855	650	1935
	15 ^[1]	18675	1857.5	675	1937.5
	20 ^[1]	18700	1860	700	1940
Mid Range	1.4/3/5/10 15 ^[1] /20 ^[1]	18900	1880	900	1960
High Range	1.4	19193	1909.3	1193	1989.3
	3	19185	1908.5	1185	1988.5
	5	19175	1907.5	1175	1987.5
	10	19150	1905	1150	1985
	15 ^[1]	19125	1902.5	1125	1982.5
	20 ^[1]	19100	1900	1100	1980

NOTE 1: Bandwidth for which a relaxation of the specified UE receiver sensitivity requirement (TS 36.101 [27] Clause 7.3) is allowed.

4.3.1.1.3 FDD reference test frequencies for operating band 3

Table 4.3.1.1.3-1: Test frequencies for E-UTRA channel bandwidth for operating band 3

Test Frequency ID	Bandwidth [MHz]	N _{UL}	Frequency of Uplink [MHz]	N _{DL}	Frequency of Downlink [MHz]
Low Range	1.4	19207	1710.7	1207	1805.7
	3	19215	1711.5	1215	1806.5
	5	19225	1712.5	1225	1807.5
	10	19250	1715	1250	1810
	15 ^[1]	19275	1717.5	1275	1812.5
	20 ^[1]	19300	1720	1300	1815
Mid Range	1.4/3/5/10 15 ^[1] /20 ^[1]	19575	1747.5	1575	1842.5
High Range	1.4	19943	1784.3	1943	1879.3
	3	19935	1783.5	1935	1878.5
	5	19925	1782.5	1925	1877.5
	10	19900	1780	1900	1875
	15 ^[1]	19875	1777.5	1875	1872.5
	20 ^[1]	19850	1775	1850	1870

NOTE 1: Bandwidth for which a relaxation of the specified UE receiver sensitivity requirement (TS 36.101 [27] Clause 7.3) is allowed.

4.3.1.1.4 FDD reference test frequencies for operating band 4

Table 4.3.1.1.4-1: Test frequencies for E-UTRA channel bandwidth for operating band 4

Test Frequency ID	Bandwidth [MHz]	N _{UL}	Frequency of Uplink [MHz]	N _{DL}	Frequency of Downlink [MHz]
Low Range	1.4	19957	1710.7	1957	2110.7
	3	19965	1711.5	1965	2111.5
	5	19975	1712.5	1975	2112.5
	10	20000	1715	2000	2115
	15	20025	1717.5	2025	2117.5
	20	20050	1720	2050	2120
Mid Range	1.4/3/5/10/15/20	20175	1732.5	2175	2132.5

High Range	1.4	20393	1754.3	2393	2154.3
	3	20385	1753.5	2385	2153.5
	5	20375	1752.5	2375	2152.5
	10	20350	1750	2350	2150
	15	20325	1747.5	2325	2147.5
	20	20300	1745	2300	2145

4.3.1.1.5 FDD reference test frequencies for operating band 5

Table 4.3.1.1.5-1: Test frequencies for E-UTRA channel bandwidth for operating band 5

Test Frequency ID	Bandwidth [MHz]	N _{UL}	Frequency of Uplink [MHz]	N _{DL}	Frequency of Downlink [MHz]
Low Range	1.4	20407	824.7	2407	869.7
	3	20415	825.5	2415	870.5
	5	20425	826.5	2425	871.5
	10 ^[1]	20450	829	2450	874
Mid Range	1.4/3/5 10 ^[1]	20525	836.5	2525	881.5
High Range	1.4	20643	848.3	2643	893.3
	3	20635	847.5	2635	892.5
	5	20625	846.5	2625	891.5
	10 ^[1]	20600	844	2600	889

NOTE 1: Bandwidth for which a relaxation of the specified UE receiver sensitivity requirement (TS 36.101 [27] Clause 7.3) is allowed.

4.3.1.1.6 FDD reference test frequencies for operating band 6

Table 4.3.1.1.6-1: Test frequencies for E-UTRA channel bandwidth for operating band 6

Test Frequency ID	Bandwidth [MHz]	N _{UL}	Frequency of Uplink [MHz]	N _{DL}	Frequency of Downlink [MHz]
Low Range	5	20675	832.5	2675	877.5
	10 ^[1]	20700	835	2700	880
Mid Range	5 10 ^[1]	20700	835	2700	880
High Range	5	20725	837.5	2725	882.5
	10 ^[1]	20700	835	2700	880

NOTE 1: Bandwidth for which a relaxation of the specified UE receiver sensitivity requirement (TS 36.101 [27] Clause 7.3) is allowed.

NOTE: For Band VI testing, the Mobile Country Code shall be set to (MCC = '442/443').

4.3.1.1.7 FDD reference test frequencies for operating band 7

Table 4.3.1.1.7-1: Test frequencies for E-UTRA channel bandwidth for operating band 7

Test Frequency ID	Bandwidth [MHz]	N _{UL}	Frequency of Uplink [MHz]	N _{DL}	Frequency of Downlink [MHz]
Low Range	5	20775	2502.5	2775	2622.5
	10	20800	2505	2800	2625
	15	20825	2507.5	2825	2627.5
	20 ^[1]	20850	2510	2850	2630
Mid Range	5/10/15 20 ^[1]	21100	2535	3100	2655
High Range	5	21425	2567.5	3425	2687.5
	10	21400	2565	3400	2685

	15	21375	2562.5	3375	2682.5
	20 ^[1]	21350	2560	3350	2680
NOTE 1: Bandwidth for which a relaxation of the specified UE receiver sensitivity requirement (TS 36.101 [27] Clause 7.3) is allowed.					

4.3.1.1.8 FDD reference test frequencies for operating band 8

Table 4.3.1.1.8-1: Test frequencies for E-UTRA channel bandwidth for operating band 8

Test Frequency ID	Bandwidth [MHz]	N _{UL}	Frequency of Uplink [MHz]	N _{DL}	Frequency of Downlink [MHz]
Low Range	1.4	21457	880.7	3457	925.7
	3	21465	881.5	3465	926.5
	5	21475	882.5	3475	927.5
	10 ^[1]	21500	885	3500	930
Mid Range	1.4/3/5 10 ^[1]	21625	897.5	3625	942.5
High Range	1.4	21793	914.3	3793	959.3
	3	21785	913.5	3785	958.5
	5	21775	912.5	3775	957.5
	10 ^[1]	21750	910	3750	955
NOTE 1: Bandwidth for which a relaxation of the specified UE receiver sensitivity requirement (TS 36.101 [27] Clause 7.3) is allowed.					

4.3.1.1.9 FDD reference test frequencies for operating band 9

Table 4.3.1.1.9-1: Test frequencies for E-UTRA channel bandwidth for operating band 9

Test Frequency ID	Bandwidth [MHz]	N _{UL}	Frequency of Uplink [MHz]	N _{DL}	Frequency of Downlink [MHz]
Low Range	5	21825	1752.4	3825	1847.4
	10	21850	1754.9	3850	1849.9
	15 ^[1]	21875	1757.4	3875	1852.4
	20 ^[1]	21900	1759.9	3900	1854.9
Mid Range	5/10 15 ^[1] /20 ^[1]	21975	1767.4	3975	1862.4
High Range	5	22125	1782.4	4125	1877.4
	10	22100	1779.9	4100	1874.9
	15 ^[1]	22075	1777.4	4075	1872.4
	20 ^[1]	22050	1774.9	4050	1869.9
NOTE 1: Bandwidth for which a relaxation of the specified UE receiver sensitivity requirement (TS 36.101 [27] Clause 7.3) is allowed.					

4.3.1.1.10 FDD reference test frequencies for operating band 10

Table 4.3.1.1.10-1: Test frequencies for E-UTRA channel bandwidth for operating band 10

Test Frequency ID	Bandwidth [MHz]	N _{UL}	Frequency of Uplink [MHz]	N _{DL}	Frequency of Downlink [MHz]
Low Range	5	22175	1712.5	4175	2112.5
	10	22200	1715	4200	2115
	15	22225	1717.5	4225	2117.5
	20	22250	1720	4250	2120
Mid Range	5/10/15/20	22450	1740	4450	2140
High Range	5	22725	1767.5	4725	2167.5
	10	22700	1765	4700	2165
	15	22675	1762.5	4675	2162.5
	20	22650	1760	4650	2160

4.3.1.1.11 FDD reference test frequencies for operating band 11

Table 4.3.1.1.11-1: Test frequencies for E-UTRA channel bandwidth for operating band 11

Test Frequency ID	Bandwidth [MHz]	N _{UL}	Frequency of Uplink [MHz]	N _{DL}	Frequency of Downlink [MHz]
Low Range	5	22775	1430.4	4775	1478.4
	10 ^[1]	22800	1432.9	4800	1480.9
	15 ^[1]	22825	1435.4	4825	1483.4
	20 ^[1]	22850	1437.9	4850	1485.9
Mid Range	5 10 ^[1] /15 ^[1] /20 ^[1]	22875	1440.4	4875	1488.4
High Range	5	22975	1450.4	4975	1498.4
	10 ^[1]	22950	1447.9	4950	1495.9
	15 ^[1]	22925	1445.4	4925	1493.4
	20 ^[1]	22900	1442.9	4900	1490.9

NOTE 1: Bandwidth for which a relaxation of the specified UE receiver sensitivity requirement (TS 36.101 [27] Clause 7.3) is allowed.

4.3.1.1.12 FDD reference test frequencies for operating band 12

Table 4.3.1.1.12-1: Test frequencies for E-UTRA channel bandwidth for operating band 12

Test Frequency ID	Bandwidth [MHz]	N _{UL}	Frequency of Uplink [MHz]	N _{DL}	Frequency of Downlink [MHz]
Low Range	1.4	23007	698.7	5007	728.7
	3	23015	699.5	5015	729.5
	5 ^[1]	23025	700.5	5025	730.5
	10 ^[1]	23050	703	5050	733
Mid Range	1.4/3 5 ^[1] /10 ^[1]	23090	707	5090	737
High Range	1.4	23173	715.3	5173	745.3
	3	23165	714.5	5165	744.5
	5 ^[1]	23155	713.5	5155	743.5
	10 ^[1]	23130	711	5130	741

NOTE 1: Bandwidth for which a relaxation of the specified UE receiver sensitivity requirement (TS 36.101 [27] Clause 7.3) is allowed.

4.3.1.1.13 FDD reference test frequencies for operating band 13

Table 4.3.1.1.13-1: Test frequencies for E-UTRA channel bandwidth for operating band 13

Test Frequency ID	Bandwidth [MHz]	N _{UL}	Frequency of Uplink [MHz]	N _{DL}	Frequency of Downlink [MHz]
Low Range	1.4	23187	777.7	5187	746.7
	3	23195	778.5	5195	747.5
	5 ^[1]	23205	779.5	5205	748.5
	10 ^[1]	23230	782	5230	751
Mid Range	1.4/3 5 ^[1] /10 ^[1]	23230	782	5230	751
High Range	1.4	23273	786.3	5273	755.3
	3	23265	785.5	5265	754.5
	5 ^[1]	23255	784.5	5255	753.5
	10 ^[1]	23230	782	5230	751

NOTE 1: Bandwidth for which a relaxation of the specified UE receiver sensitivity requirement (TS 36.101 [27] Clause 7.3) is allowed.

4.3.1.1.14 FDD reference test frequencies for operating band 14

Table 4.3.1.1.14-1: Test frequencies for E-UTRA channel bandwidth for operating band 14

Test Frequency ID	Bandwidth [MHz]	N _{UL}	Frequency of Uplink [MHz]	N _{DL}	Frequency of Downlink [MHz]
Low Range	1.4	23287	788.7	5287	758.7
	3	23295	789.5	5295	759.5
	5 ^[1]	23305	790.5	5305	760.5
	10 ^[1]	23330	793	5330	763
Mid Range	1.4/3 5 ^[1] /10 ^[1]	23330	793	5330	763
High Range	1.4	23373	797.3	5373	767.3
	3	23365	796.5	5365	766.5
	5 ^[1]	23355	795.5	5355	765.5
	10 ^[1]	23330	793	5330	763

NOTE 1: Bandwidth for which a relaxation of the specified UE receiver sensitivity requirement (TS 36.101 [27] Clause 7.3) is allowed.

4.3.1.1.15 FDD reference test frequencies for operating band 15

[FFS; not yet specified in TS 36.101]

4.3.1.1.16 FDD reference test frequencies for operating band 16

[FFS; not yet specified in TS 36.101]

4.3.1.1.17 FDD reference test frequencies for operating band 17

Table 4.3.1.1.17-1: Test frequencies for E-UTRA channel bandwidth for operating band 17

Test Frequency ID	Bandwidth [MHz]	N _{UL}	Frequency of Uplink [MHz]	N _{DL}	Frequency of Downlink [MHz]
Low Range	1.4	23737	704.7	5737	734.7
	3	23745	705.5	5745	735.5
	5 ^[1]	23755	706.5	5755	736.5
	10 ^[1]	23780	709	5780	739
Mid Range	1.4/3 5 ^[1] /10 ^[1]	23790	710	5790	740
High Range	1.4	23843	715.3	5843	745.3
	3	23835	714.5	5835	744.5
	5 ^[1]	23825	713.5	5825	743.5
	10 ^[1]	23800	711	5800	741

NOTE 1: Bandwidth for which a relaxation of the specified UE receiver sensitivity requirement (TS 36.101 [27] Clause 7.3) is allowed.

4.3.1.1.18 FDD reference test frequencies for operating band 18

Table 4.3.1.1.18-1: Test frequencies for E-UTRA channel bandwidth for operating band 18

Test Frequency ID	Bandwidth [MHz]	N _{UL}	Frequency of Uplink [MHz]	N _{DL}	Frequency of Downlink [MHz]
Low Range	5	23875	817.5	5875	862.5
	10 ^[1]	23900	820	5900	865
	15 ^[1]	23925	822.5	5925	867.5
Mid Range	5/10 ^[1] /15 ^[1]	23925	822.5	5925	867.5
High range	5	23975	827.5	5975	872.5
	10 ^[1]	23950	825	5950	870
	15 ^[1]	23925	822.5	5925	867.5

NOTE 1: Bandwidth for which a relaxation of the specified UE receiver sensitivity requirement (TS 36.101 [27] Clause 7.3) is allowed.

4.3.1.1.19 FDD reference test frequencies for operating band 19

Table 4.3.1.1.19-1: Test frequencies for E-UTRA channel bandwidth for operating band 19

Test Frequency ID	Bandwidth [MHz]	N _{UL}	Frequency of Uplink [MHz]	N _{DL}	Frequency of Downlink [MHz]
Low Range	5	24025	832.5	6025	877.5
	10 ^[1]	24050	835	6050	880
	15 ^[1]	24075	837.5	6075	882.5
Mid Range	5/10 ^[1] /15 ^[1]	24075	837.5	6075	882.5
High range	5	24125	842.5	6125	887.5
	10 ^[1]	24100	840	6100	885
	15 ^[1]	24075	837.5	6075	882.5

NOTE 1: Bandwidth for which a relaxation of the specified UE receiver sensitivity requirement (TS 36.101 [27] Clause 7.3) is allowed.

4.3.1.2 TDD Mode Test frequencies

4.3.1.2.1 TDD reference test frequencies for Operating Band 33

Table 4.3.1.2.1-1: Test frequencies for E-UTRA channel bandwidth for operating band 33

Test Frequency ID	Bandwidth [MHz]	EARFCN	Frequency (UL and DL) [MHz]
Low Range	5	36025	1902.5
	10	36050	1905
	15	36075	1907.5
	20	36100	1910
Mid Range	5/10/15/20	36100	1910
High Range	5	36175	1917.5
	10	36150	1915
	15	36125	1912.5
	20	36100	1910

4.3.1.2.2 TDD reference test frequencies for Operating Band 34

Table 4.3.1.2.2-1: Test frequencies for E-UTRA channel bandwidth for operating band 34

Test Frequency ID	Bandwidth [MHz]	EARFCN	Frequency (UL and DL) [MHz]
Low Range	5	36225	2012.5
	10	36250	2015
	15	36275	2017.5
Mid Range	5/10/15	36275	2017.5
High Range	5	36325	2022.5
	10	36300	2020
	15	36275	2017.5

4.3.1.2.3 TDD reference test frequencies for Operating Band 35

Table 4.3.1.2.3-1: Test frequencies for E-UTRA channel bandwidth for operating band 35

Test Frequency ID	Bandwidth [MHz]	EARFCN [MHz]	Frequency (UL and DL) [MHz]
Low Range	1.4	36357	1850.7
	3	36365	1851.5
	5	36375	1852.5
	10	36400	1855
	15	36425	1857.5
	20	36450	1860
Mid Range	1.4/3/5/10/15/20	36650	1880
High Range	1.4	36943	1909.3
	3	36935	1908.5
	5	36925	1907.5
	10	36900	1905
	15	36875	1902.5
	20	36850	1900

4.3.1.2.4 TDD reference test frequencies for Operating Band 36

Table 4.3.1.2.4-1: Test frequencies for E-UTRA channel bandwidth for operating band 36

Test Frequency ID	Bandwidth [MHz]	EARFCN [MHz]	Frequency (UL and DL) [MHz]
Low Range	1.4	36957	1930.7
	3	36965	1931.5
	5	36975	1932.5
	10	37000	1935
	15	37025	1937.5
	20	37050	1940
Mid Range	1.4/3/5/10/15/20	37250	1960
High Range	1.4	37543	1989.3
	3	37535	1988.5
	5	37525	1987.5
	10	37500	1985
	15	37475	1982.5
	20	37450	1980

4.3.1.2.5 TDD reference test frequencies for Operating Band 37

Table 4.3.1.2.5-1: Test frequencies for E-UTRA channel bandwidth for operating band 37

Test Frequency ID	Bandwidth [MHz]	EARFCN [MHz]	Frequency (UL and DL) [MHz]
Low Range	5	37575	1912.5
	10	37600	1915
	15	37625	1917.5
	20	37650	1920
Mid Range	5/10/15/20	37650	1920
High Range	5	37725	1927.5
	10	37700	1925
	15	37675	1922.5
	20	37650	1920

4.3.1.2.6 TDD reference test frequencies for Operating Band 38

Table 4.3.1.2.6-1: Test frequencies for E-UTRA channel bandwidth for operating band 38

Test Frequency ID	Bandwidth [MHz]	EARFCN	Frequency (UL and DL) [MHz]
Low Range	5	37775	2572.5
	10	37800	2575
Mid Range	5/10	38000	2595
High Range	5	38225	2617.5
	10	38200	2615

4.3.1.2.7 TDD reference test frequencies for Operating Band 39

Table 4.3.1.2.7-1: Test frequencies for E-UTRA channel bandwidth for operating band 39

Test Frequency ID	Bandwidth [MHz]	EARFCN	Frequency (UL and DL) [MHz]
Low Range	5	38275	1882.5
	10	38300	1885
	15	38325	1887.5
	20	38350	1890
Mid Range	5/10/15/20	38450	1900
High Range	5	38625	1917.5
	10	38600	1915
	15	38575	1912.5
	20	38550	1910

4.3.1.2.8 TDD reference test frequencies for Operating Band 40

Table 4.3.1.2.8-1: Test frequencies for E-UTRA channel bandwidth for operating band 40

Test Frequency ID	Bandwidth [MHz]	EARFCN	Frequency (UL and DL) [MHz]
Low Range	5	38675	2302.5
	10	38700	2305
	15	38725	2307.5
	20	38750	2310
Mid Range	5/10/15/20	39150	2350
High Range	5	39625	2397.5
	10	39600	2395
	15	39575	2392.5
	20	39550	2390

4.3.2 Radio conditions

4.3.2.1 Normal propagation condition

The downlink connection between the System Simulator and the UE is without Additive White Gaussian Noise, and has no fading or multipath effects.

The uplink connection between the UE and System Simulator is without Additive White Gaussian Noise, and has no fading or multipath effects.

4.3.3 Physical channel allocations

4.3.3.1 Antennas

If the UE has two Rx antennas, the same downlink signal is applied to each one. Both UE Rx antennas shall be connected unless otherwise stated in the test case.

If the UE has one Rx antenna, the downlink signal is applied to it.

4.3.3.2 Downlink physical channels and physical signals

The Downlink Physical channels and Physical signals used and their relative powers are specified in table 4.3.3.2-1. The details of downlink power allocation for PDSCH channel are described in TS 36.213 [29] clause 5.2.

Table 4.3.3.2-1: Power allocation for OFDM symbols and reference signals, single SS Tx antenna

Physical Channel	EPRE Ratio
PBCH	PBCH_RA = 0 dB
	PBCH_RB = 0 dB
PSS	PSS_RA = 0 dB
SSS	SSS_RA = 0 dB
PCFICH	PCFICH_RB = 0 dB
PDCCH	PDCCH_RA = 0 dB
	PDCCH_RB = 0 dB
PDSCH	PDSCH_RA = 0 dB
	PDSCH_RB = 0 dB
PHICH	PHICH_RB = 0 dB

4.3.3.3 Mapping of downlink physical channels and signals to physical resources

Parameters for mapping of downlink physical channels and signals are specified as follows.

- Normal Cyclic Prefix
- N_{ID}^{cell} , Physical layer cell identity = 0 is used as the default physical layer cell identity
- CFI = 3 for 1.4, 3 and 5 MHz system bandwidths
= 2 for 10, 15 and 20 MHz system bandwidths
- $N_g = 1$
- PHICH duration = Normal

For Signalling testing, the default system bandwidth is 5MHz and single SS Tx antenna is used unless specified otherwise in the test case. The mapping of downlink physical channels to physical resources for Single Tx Antenna and 5 MHz system bandwidth is described in table 4.3.3.3-1.

For RF testing, the mapping of DL physical channels to resource element is defined TS 36.521-1 [21] Annex C.1.

Table 4.3.3.3-1: Mapping of DL Physical Channels to Resource Elements for Single SS Tx Antenna and 5 MHz System Bandwidth (FDD)

Physical channel	Time Domain Location	Frequency Domain Location	Note
PBCH	Symbols 0 to 3 of slot 1 of subframe 0 of each radio frame	Occupies 72 subcarriers centred on the DC subcarrier	Mapping rule is specified in TS36.211 [35] sub clause 6.6.4
PSS	Symbol 6 of slot 0 and 10 of each radio frame	Occupies 62 subcarriers centred on the DC subcarrier	Mapping rule is specified in TS36.211 [35] sub clause 6.11.1.2
SSS	Symbol 5 of slots 0 and 10 of each radio frame	Occupies 62 subcarriers centred on the DC subcarrier	Mapping rule is specified in TS36.211 [35] sub clause 6.11.2.2
PCFICH	Symbol 0 of each subframe	Maps into 4 REGs uniformly spread in the frequency domain over the whole system bandwidth.	Mapping rule is specified in TS36.211 [35] sub clause 6.7.4 - CELL_ID = 0
PHICH	Symbol 0 of each subframe	Each PHICH group maps into 3 REGs in the frequency domain on the REGs not assigned to PCFICH over the whole system bandwidth,	Mapping rule is specified in TS36.211 [35] sub clause 6.9.3 - CELL_ID = 0 - Number of PHICH group = 4
PDCCH	Symbols 0, 1, 2 of each subframe	The remaining REGs not allocated to both PCFICH and PHICH are used for PDCCH	Mapping rule is specified in TS36.211 [35] sub clause 6.8.5 - CFI = 3
PDSCH	All remaining OFDM symbols of each subframe not allocated to PDCCH	For Subframe 0, REs not allocated to RS, PSS, SSS and PBCH is allocated to PDSCH For Subframe 5, REs not allocated to RS, PSS and SSS is allocated to PDSCH For other subframes, REs not allocated to RS is allocated to PDSCH	

NOTE: In case a single cell-specific RS is configured, cell-specific RS shall be assume to be present on antenna ports 0 and 1 for the purpose of mapping a symbol-quadruplet to a REG (resource element group). (See TS 36.211 [35] sub clause 6.2.4)

Table 4.3.3-2: Mapping of DL Physical Channels to Resource Elements for Single SS Tx Antenna and 5 MHz System Bandwidth (TDD)

Physical channel	Time Domain Location	Frequency Domain Location	Note
PBCH	Symbols 0 to 3 of slot 1 of subframe 0 of each radio frame	Occupies 72 subcarriers centered on the DC subcarrier	Mapping rule is specified in TS36.211 [35] subclause 6.6.4
PSS	Symbol 2 of slot 2 and 12 of each radio frame	Occupies 62 subcarriers centered on the DC subcarrier	Mapping rule is specified in TS36.211 [35] subclause 6.11.1.2
SSS	Symbol 6 of slots 1 and 11 of each radio frame	Occupies 62 subcarriers centered on the DC subcarrier	Mapping rule is specified in TS36.211 [35] subclause 6.11.2.2
PCFICH	Symbol 0 of each downlink subframe and Special subframe	Maps into 4 REGs uniformly spread in the frequency domain over the whole system bandwidth.	Mapping rule is specified in TS36.211 [35] subclause 6.7.4 - CELL_ID = 0
PHICH	Symbol 0 of each downlink subframe and Special subframe	Each PHICH group maps into 3 REGs in the frequency domain on the REGs not assigned to PCFICH over the whole system bandwidth,	Mapping rule is specified in TS36.211 [35] subclause 6.9.3 - CELL_ID = 0 - Number of PHICH group = 4
PDCCH	Symbols 0, 1 of subframe 1, 6 and Symbols 0, 1, 2 of other downlink subframes	The remaining REGs not allocated to both PCFICH and PHICH are used for PDCCH	Mapping rule is specified in TS36.211 [35] subclause 6.8.5 - CFI = 3
PDSCH	All remaining OFDM symbols of each downlink subframe and DwPTS not allocated to PDCCH	For Subframe 0, REs not allocated to RS, SSS and PBCH is allocated to PDSCH For Subframe 5, REs not allocated to RS and SSS is allocated to PDSCH For Subframe 1 and 6, REs not allocated to RS, PSS, GP and UpPTS is allocated to PDSCH For other downlink subframes, REs not allocated to RS is allocated to PDSCH	

NOTE 1: In case a single cell-specific RS is configured, cell-specific RS shall be assumed to be present on antenna ports 0 and 1 for the purpose of mapping a symbol-quadruplet to a REG (resource element group). (See TS 36.211 [35] subclause 6.2.4)

NOTE 2: In case the default TDD configuration for subframe assignment and special subframe patterns (see subclause 4.6.3)4.3.3.4 Uplink physical channels and physical signals

[FFS].

4.3.3.5 Mapping of uplink physical channels and signals to physical resources

[FFS].

4.3.4 Signal levels

4.3.4.1 Downlink signal levels

The downlink power settings in table 4.3.4.1-1 are used unless otherwise specified in a test case.

Table 4.3.4.1-1: Default Downlink power levels

	Unit	Channel bandwidth					
		1.4 MHz	3 MHz	5 MHz	10 MHz	15 MHz	20 MHz
Number of RBs		6	15	25	50	75	100
Channel BW Power	dBm	-66	-62	-60	-57	-55	-54
RS EPRE	dBm/15kHz	-85	-85	-85	-85	-85	-85
Note 1: The channel bandwidth powers are informative, based on -85dBm/15kHz RS_EPRES, then scaled according to the number of RBs and rounded to the nearest integer dBm value. Full RE allocation with no boost or deboost is assumed.							
Note 2: The power level is specified at each UE Rx antenna.							

It is [FFS] whether there is a requirement to specify constant power throughout all OFDM symbols, and if so how unallocated Resource elements should be treated.

The default signal level uncertainty is +/-3dB at each test port, for any level specified. If the uncertainty value is critical for the test purpose a tighter uncertainty is specified for the related test case in TS 36.521-1 [21] Annex F or in TS 36.521-3 [34] Annex F

4.3.4.2 Uplink signal levels

[FFS]

4.3.5 Standard test signals

4.3.5.1 Downlink test signals

[FFS]

4.3.5.2 Uplink test signals

[FFS]

4.3.6 Physical layer parameters

4.3.6.1 Downlink physical layer parameters

4.3.6.1.1 Physical layer parameters for DCI format 0

Default physical layer parameters for DCI format 0 are specified in table 4.3.6.1.1-1.

Table 4.3.6.1.1-1: Physical layer parameters for DCI format 0

Parameter	Value	Value in binary
Flag for format 0/format 1A differentiation	format 0	"0"
Hopping flag	w/o Hopping	"0"
Resource block assignment and hopping resource allocation	depending on test parameters	-
Modulation and coding scheme and redundancy version	depending on test parameters	-
New data indicator	Set for every data transmission/retransmission according to the rules specified in TS 36.321	-
TPC command for scheduled PUSCH	0 dB (accumulated TPC)	"01"
Cyclic shift for DM RS	0	"000"
UL index (TDD only)	2 bits as defined in sections 5.1.1.1 and 8 of TS 36.213. This field is present only for TDD configuration 0	-
Downlink Assignment Index (TDD only)	2 bits as defined in Table 7.3-X in TS 36.213. It represents the total number of PDSCH subframes with and without PDCCH and PDCCH indicating downlink SPS release in the window. This field is present only for TDD configuration 1-6	-
CQI request	w/o Aperiodic CQI	"0"

4.3.6.1.2 Physical layer parameters for DCI format 1

Default physical layer parameters for DCI format 1 are specified in table 4.3.6.1.2-1.

Table 4.3.6.1.2-1: Physical layer parameters for DCI format 1

Parameter	Value	Value in binary
Resource allocation header	Resource allocation type 0	"0"
Resource block assignment	depending on test parameters	-
Modulation and coding scheme	depending on test parameters	-
HARQ process number	depending on test parameters, 3bits for FDD, 4 bits for TDD.	-
New data indicator	Set for every data transmission/retransmission according to the rules specified in TS 36.321	-
Redundancy version	depending on test parameters	"00"
TPC command for PUCCH	0 dB (accumulated TPC)	"01"
Downlink Assignment Index (TDD only)	2 bits as defined in Table 7.3-X in TS 36.213. It represents the number of PDSCH with PDCCH and PDCCH indicating downlink SPS release in the window up to the present subframe. This is present for all the uplink-downlink configurations and only applies to uplink-downlink configuration 1-6	-

4.3.6.1.3 Physical layer parameters for DCI format 1A

Default physical layer parameters for DCI format 1A are specified in table 4.3.6.1.3-1.

Table 4.3.6.1.3-1: Physical layer parameters for DCI format 1A

Parameter	Value	Value in binary
Flag for format 0/format 1A differentiation	format 1A	"1"
Localized/Distributed VRB assignment flag	Localized VRB assignment	"0"
Resource block assignment	depending on test parameters	-
Modulation and coding scheme	depending on test parameters	-
HARQ process number	depending on test parameters, 3bits for FDD, 4 bits for TDD.	-
New data indicator	Set for every data transmission/retransmission according to the rules specified in TS 36.321	-
Redundancy version	depending on test parameters	"00"
TPC command for PUCCH	0 dB (accumulated TPC)	"01"
Downlink Assignment Index (TDD only)	2 bits as defined in Table 7.3-X in TS 36.213. It represents the number of PDSCH with PDCCH and PDCCH indicating downlink SPS release in the window up to the present subframe. This is present for all the uplink-downlink configurations and only applies to uplink-downlink configuration 1-6	-

4.3.6.1.4 Physical layer parameters for DCI format 1C

Default physical layer parameters for DCI format 1C are specified in table 4.3.6.1.4-1.

Table 4.3.6.1.4-1: Physical layer parameters for DCI format 1C

Parameter	Value	Value in binary
gap value ($N_{RB} \geq 50$)	gap1	"0"
Resource block assignment	depending on test parameters	-
Transport block size index	depending on test parameters	-

4.3.6.1.5 Physical layer parameters for DCI format 2

Default physical layer parameters for DCI format 2 are specified in table 4.3.6.1.5-1.

Table 4.3.6.1.5-1: Physical layer parameters for DCI format 2

Parameter	Value	Value in binary
Resource allocation header	Resource allocation type 0	"0"
Resource block assignment	depending on test parameters	-
TPC command for PUCCH	0 dB (accumulated TPC)	"01"
Downlink Assignment Index (TDD only)	2 bits as defined in Table 7.3-X in TS 36.213. It represents the number of PDSCH with PDCCH and PDCCH indicating downlink SPS release in the window up to the present subframe. This is present for all the uplink-downlink configurations and only applies to uplink-downlink configuration 1-6	-
HARQ process number	depending on test parameters, 3bits for FDD, 4 bits for TDD.	-
Transport block to codeword swap flag	No swap	"0"
Modulation and coding scheme (transport block 1)	depending on test parameters	-
New data indicator (transport block 1)	Set for every data transmission/retransmission according to the rules specified in TS 36.321	-
Redundancy version (transport block 1)	depending on test parameters	-
Modulation and coding scheme (transport block 2)	depending on test parameters	-
New data indicator (transport block 2)	Set for every data transmission/retransmission according to the rules specified in TS 36.321	-
Redundancy version (transport block 2)	depending on test parameters	-
Precoding information	TRI = 2, codebook index = 1	"000"

4.3.6.1.6 Physical layer parameters for DCI format 2A

Default physical layer parameters for DCI format 2A are specified in table 4.3.6.1.6-1.

Table 4.3.6.1.6-1: Physical layer parameters for DCI format 2A

Parameter	Value	Value in binary
Resource allocation header	Resource allocation type 0	"0"
Resource block assignment	depending on test parameters	-
TPC command for PUCCH	0 dB (accumulated TPC)	"01"
Downlink Assignment Index (TDD only)	2 bits as defined in Table 7.3-X in TS 36.213. It represents the number of PDSCH with PDCCH and PDCCH indicating downlink SPS release in the window up to the present subframe. This is present for all the uplink-downlink configurations and only applies to uplink-downlink configuration 1-6	-
HARQ process number	depending on test parameters, 3bits for FDD, 4 bits for TDD.	-
Transport block to codeword swap flag	No swap	"0"
Modulation and coding scheme (transport block 1)	depending on test parameters	-
New data indicator (transport block 1)	Set for every data transmission/retransmission according to the rules specified in TS 36.321	-
Redundancy version (transport block 1)	depending on test parameters	-
Modulation and coding scheme (transport block 2)	depending on test parameters	-
New data indicator (transport block 2)	Set for every data transmission/retransmission according to the rules specified in TS 36.321	-
Redundancy version (transport block 2)	depending on test parameters	-
Precoding information	N/A	N/A

4.4 Reference system configurations

The reference system configurations specified in this sub clause apply to all test cases unless otherwise specified.

4.4.1 Simulated network scenarios

The UE will eventually have to operate in either single mode networks (FDD or TDD), dual mode networks (FDD+TDD), or inter-RAT networks ((FDD or TDD) + (UTRA FDD, UTRA TDD, GSM, HRPD or 1xRTT)).

Simulated network scenarios to be tested are listed in this sub clause.

NOTE 1: The number of cells specified does not necessarily correspond to the maximum number of resources to be configured simultaneously in test equipment. Please refer to Table 6.1-1 for such information.

NOTE 2: For NAS test cases see sub clause 6.3.2.

4.4.1.1 Single cell network scenarios

For FDD and TDD basic single cell environment, Cell 1 is used.

4.4.1.2 Intra E-UTRA multi cell network scenarios

For FDD and TDD basic intra-frequency multi cell environment, Cell 1, Cell 2 and Cell 4 are used.

For FDD and TDD basic inter-frequency multi cell environment, Cell 1, Cell 3 and Cell 6 are used.

For FDD and TDD basic inter-band cell environment, Cell 1 and Cell 10 are used.

For FDD and TDD multi tracking area intra-frequency multi cell environment, Cell 1 and Cell 11 are used.

For FDD and TDD multi tracking area inter-frequency multi cell environment, Cell 1 and Cell 23 are used.

For FDD and TDD multi PLMN inter-frequency multi cell environment, Cell 1, Cell 12, Cell 13, Cell 14 are used.

4.4.1.3 Dual mode network scenarios

[FFS for FDD+TDD]

4.4.1.4 3GPP Inter-RAT network scenarios

For FDD and TDD basic inter-RAT cell environment with UTRA FDD or UTRA TDD, Cell 1 and Cell 5 are used.

For FDD and TDD inter-RAT cell environment with multi UTRA FDD or UTRA TDD cells, Cell 1 and Cell 7, Cell 8 and Cell 9 is used.

For FDD and TDD inter-RAT cell environment with GERAN, Cell 1 and Cell 24 are used.

For FDD and TDD inter-RAT cell environment with multi GERAN cells, Cell 1 and Cell 25, Cell 26 are used.

For FDD and TDD inter-RAT cell environment with (UTRA FDD or UTRA TDD) and GERAN, Cell 1, Cell 5 and Cell 24 are used.

4.4.1.5 3GPP2 Inter-RAT network scenarios

For FDD and TDD inter-RAT cell environment with HRPD, Cell 1 and Cell 15 are used.

For FDD and TDD inter-RAT cell environment with multi HRPD cells, Cell 1 and Cell 16, Cell 17 and Cell 18 are used.

For FDD and TDD inter-RAT cell environment with 1xRTT, Cell 1 and Cell 19 are used.

For FDD and TDD inter-RAT cell environment with multi 1xRTT cells, Cell 1 and Cell 20, Cell 21 and Cell 22 are used.

4.4.2 Simulated cells

Editor's Note: It is FFS how many simultaneous cells are needed for testing.

NOTE: For NAS test cases, see subclause 6.3.2.

NOTE: Test frequency and range defined in table 4.4.2-1 do not apply to 36.521-1 test cases.

Test frequencies and simulated cells are defined in table 4.4.2-1. For E-UTRA cells, f1 is the default test frequency. For UTRA cells, f8 is the default test frequency. For GERAN cells, f11 is the default test frequency. For CDMA2000 HRPD cells, f14 is the default test frequency. For CDMA 2000 1xRTT cells, f17 is the default test frequency.

Default parameters for simulated cells are specified in table 4.4.2-1A and table 4.4.2-2.

Common parameters for simulated cells are specified in subclauses 4.4.3 to 4.4.6.

Other cell specific parameters are specified in subclause 4.4.7.

Table 4.4.2-1: Definition of test frequencies and simulated cells

Test frequency	RAT	Operating band	Range	Simulated cells
f1	E-UTRA	Operating band under test	Mid	Cell 1, Cell 2, Cell 4, Cell 11
f2	E-UTRA	Operating band under test	High	Cell 3, Cell 12, Cell 23
f3	E-UTRA	Operating band under test	Low	Cell 6, Cell 13
f4	E-UTRA	Operating band under test	[FFS]	Cell 14
f5	E-UTRA	Operating band for inter-band cells	Mid	Cell 10
f6	E-UTRA	Operating band for inter-band cells	High	
f7	E-UTRA	Operating band for inter-band cells	Low	
f8	UTRA	Operating band for UTRA cells	Mid	Cell 5, Cell 7
f9	UTRA	Operating band for UTRA cells	High	Cell 8
f10	UTRA	Operating band for UTRA cells	Low	Cell 9
f11	GERAN	Operating band for GERAN cells	Mid	Cell 24
f12	GERAN	Operating band for GERAN cells	High	Cell 25
f13	GERAN	Operating band for GERAN cells	Low	Cell 26
f14	CDMA2000 HRPD	Operating band for CDMA2000 HRPD cells	FFS	Cell 15, Cell 16
f15	CDMA2000 HRPD	Operating band for CDMA2000 HRPD cells	FFS	Cell 17
f16	CDMA2000 HRPD	Operating band for CDMA2000 HRPD cells	FFS	Cell 18
f17	CDMA2000 1xRTT	Operating band for CDMA2000 1xRTT cells	FFS	Cell 19, Cell 20
f18	CDMA2000 1xRTT	Operating band for CDMA2000 1xRTT cells	FFS	Cell 21
f19	CDMA2000 1xRTT	Operating band for CDMA2000 1xRTT cells	FFS	Cell 22

Table 4.4.2-1A: Default E-UTRA parameters for simulated cells

cell ID	E-UTRAN Cell Identifier		Physical layer cell identity
	eNB Identifier	Cell Identity	
Cell 1	'0000 0000 0000 0000 0001'B	'0000 0000'B	0
Cell 2	'0000 0000 0000 0000 0001'B	'0000 0010'B	2
Cell 3	'0000 0000 0000 0000 0010'B	'0000 0011'B	3
Cell 4	'0000 0000 0000 0000 0011'B	'0000 0100'B	4
Cell 6	'0000 0000 0000 0000 0100'B	'0000 0110'B	6
Cell 10	'0000 0000 0000 0000 0101'B	'0000 1010'B	10
Cell 11	'0000 0000 0000 0000 0110'B	'0000 1011'B	11
Cell 12	'0000 0000 0000 0000 0010'B	'0000 1100'B	12
Cell 13	'0000 0000 0000 0000 0100'B	'0000 1101'B	13
Cell 14	'0000 0000 0000 0000 0111'B	'0000 1110'B	14
Cell 23	'0000 0000 0000 0000 0110'B	'0001 0111'B	23

Table 4.4.2-2: Default NAS parameters for simulated cells

cell ID	Tracking Area			TA# list (Note 1)	GUTI (Note 2)		M-TMSI	
	TA#	PLMN			TAC	MME Identifier		
		MCC	MNC			MME Group ID		MME Code
Cell 1	TAI-1	(Note 3)		1	TAI-1	1	Arbitrarily selected according to TS 23.003 subclause 2.8 [2].	
Cell 2	TAI-1	(Note 3)		1	TAI-1	1		
Cell 3	TAI-1	(Note 3)		1	TAI-1	1		
Cell 4	TAI-1	(Note 3)		1	TAI-1	1		
Cell 6	TAI-1	(Note 3)		1	TAI-1	1		
Cell 10	TAI-1	(Note 3)		1	TAI-1	1		
Cell 11	TAI-2	(Note 3)		2	TAI-2	1		
Cell 23	TAI-2	(Note 3)		2	TAI-2	1		
Cell 12	TAI-3	002	11	1	TAI-3	1		
Cell 13	TAI-4	003	21	1	TAI-4	1		
Cell 14	TAI-5	004	31	1	TAI-5	1		
NOTE 1: The value(s) in the column TA# list indicates TAI(s) included in the response messages of the registration procedure (ATTACH ACCEPT or TRACKING AREA UPDATE ACCEPT) when the UE performs the registration procedure on a corresponding cell.								
NOTE 2: The value in the column GUTI indicates GUTI included in the response messages of the registration procedure (ATTACH ACCEPT or TRACKING AREA UPDATE ACCEPT) when the UE performs the registration procedure on a corresponding cell.								
NOTE 3: Set to the same Mobile Country Code and Mobile Network Code stored in EF _{IMSI} on the test USIM card (subclause 4.9.3).								

4.4.3 Common parameters for simulated E-UTRA cells

The parameters specified in this sub clause apply to all simulated E-UTRA cells unless otherwise specified.

4.4.3.1 Common configurations of system information blocks

4.4.3.1.1 Combinations of system information blocks

The combination of system information blocks required by a test case depends on the test case scenario. In this clause, the following combinations of system information blocks are defined.

Combination 1 is the default combination which applies to the following test case scenarios:

- E-UTRA FDD single cell scenario
- E-UTRA TDD single cell scenario
- E-UTRA FDD intra-frequency multi cell scenario
- E-UTRA TDD intra-frequency multi cell scenario
- E-UTRA FDD+TDD dual mode multi cell scenario

Combination 2 applies to the following test case scenarios:

- E-UTRA FDD intra-frequency multi cell scenario with neighbouring cell related information
- E-UTRA TDD intra-frequency multi cell scenario with neighbouring cell related information

Combination 3 applies to the following test case scenarios:

- E-UTRA FDD inter-frequency multi cell scenario
- E-UTRA TDD inter-frequency multi cell scenario
- E-UTRA FDD inter-band multi cell scenario
- E-UTRA TDD inter-band multi cell scenario

Combination 4 applies to the following test case scenarios:

- 3GPP inter-RAT E-UTRA FDD + UTRA FDD multi cell scenario
- 3GPP inter-RAT E-UTRA TDD + UTRA TDD multi cell scenario

Editor’s note: 3GPP Inter-RAT multi cell scenarios with other combinations of E-UTRA and UTRA modes are FFS.

Combination 5 applies to the following test case scenarios:

- 3GPP inter-RAT E-UTRA FDD + GERAN multi cell scenario
- 3GPP inter-RAT E-UTRA TDD + GERAN multi cell scenario

Combination 6 applies to the following test case scenarios:

- 3GPP2 inter-RAT E-UTRA FDD + HRPD multi cell scenario
- 3GPP2 inter-RAT E-UTRA TDD + HRPD multi cell scenario
- 3GPP2 inter-RAT E-UTRA FDD + 1xRTT multi cell scenario
- 3GPP2 inter-RAT E-UTRA TDD + 1xRTT multi cell scenario

Editor’s note: 3GPP2 Inter-RAT multi cell scenarios with E-UTRA + HRPD + 1xRTT are FFS.

Combination 7 applies to the following test case scenarios:

- E-UTRA FDD + home eNB multi cell scenario
- E-UTRA TDD + home eNB multi cell scenario

Combination 8 applies to the following test case scenarios:

- E-UTRA FDD ETWS single cell scenario
- E-UTRA TDD ETWS single cell scenario

Combination 9 applies to the following test case scenarios:

- E-UTRA FDD inter-frequency + 3GPP inter-RAT UTRA multi-cell scenario
- E-UTRA TDD inter-frequency + 3GPP inter-RAT UTRA multi-cell scenario

Combination 10 applies to the following test case scenarios:

- 3GPP inter-RAT E-UTRA FDD + UTRA FDD + GERAN multi cell scenario
 - 3GPP inter-RAT E-UTRA TDD + UTRA TDD + GERAN multi cell scenario
- The combinations of system information blocks are defined in table 4.4.3.1.1-1.

Table 4.4.3.1.1-1: Combinations of system information blocks

Combination No.	System information block type									
	SIB2	SIB3	SIB4	SIB5	SIB6	SIB7	SIB8	SIB9	SIB10	SIB11
1	X	X								
2	X	X	X							
3	X	X		X						
4	X	X			X					
5	X	X				X				
6	X	X					X			
7	X	X	X					X		
8	X	X							X	X
9	X	X		X	X					
10	X	X			X	X				

4.4.3.1.2 Scheduling of system information blocks

The scheduling configurations for combinations of system information blocks are defined in the following tables.

Table 4.4.3.1.2-1: Scheduling for combination 1

Scheduling Information No.	Periodicity [radio frames]	Mapping of system information blocks
1	16	SIB2
2	See sub clause 4.4.3.4	SIB3

Table 4.4.3.1.2-2: Scheduling for combination 2

Scheduling Information No.	Periodicity [radio frames]	Mapping of system information blocks
1	16	SIB2
2	See sub clause 4.4.3.4	SIB3
3	See sub clause 4.4.3.4	SIB4

Table 4.4.3.1.2-3: Scheduling for combination 3

Scheduling Information No.	Periodicity [radio frames]	Mapping of system information blocks
1	16	SIB2
2	See sub clause 4.4.3.4	SIB3
3	See sub clause 4.4.3.4	SIB5

Table 4.4.3.1.2-4: Scheduling for combination 4

Scheduling Information No.	Periodicity [radio frames]	Mapping of system information blocks
1	16	SIB2
2	See sub clause 4.4.3.4	SIB3
3	See sub clause 4.4.3.4	SIB6

Table 4.4.3.1.2-5: Scheduling for combination 5

Scheduling Information No.	Periodicity [radio frames]	Mapping of system information blocks
1	16	SIB2
2	See sub clause 4.4.3.4	SIB3
3	See sub clause 4.4.3.4	SIB7

Table 4.4.3.1.2-6: Scheduling for combination 6

Scheduling Information No.	Periodicity [radio frames]	Mapping of system information blocks
1	16	SIB2
2	See sub clause 4.4.3.4	SIB3
3	See sub clause 4.4.3.4	SIB8

Table 4.4.3.1.2-7: Scheduling for combination 7

Scheduling Information No.	Periodicity [radio frames]	Mapping of system information blocks
1	16	SIB2
2	See sub clause 4.4.3.4	SIB3
3	See subclause 4.4.3.4	SIB4
4	FFS	SIB9

Table 4.4.3.1.2-8: Scheduling for combination 8

Scheduling Information No.	Periodicity [radio frames]	Mapping of system information blocks
1	16	SIB2
2	See sub clause 4.4.3.4	SIB3
3	FFS	SIB11
4	FFS	SIB10

Table 4.4.3.1.2-9: Scheduling for combination 9

Scheduling Information No.	Periodicity [radio frames]	Mapping of system information blocks
1	16	SIB2
2	See sub clause 4.4.3.4	SIB3
3	See sub clause 4.4.3.4	SIB5, SIB6

Table 4.4.3.1.2-10: Scheduling for combination 10

Scheduling Information No.	Periodicity [radio frames]	Mapping of system information blocks
1	16	SIB2
2	See sub clause 4.4.3.4	SIB3
3	See sub clause 4.4.3.4	SIB6
4	See sub clause 4.4.3.4	SIB7

4.4.3.2 Common contents of system information messages

- *MasterInformationBlock*

The *MasterInformationBlock* includes the system information transmitted on BCH.

Table 4.4.3.2-1: *MasterInformationBlock*

Information Element	Value/remark	Comment	Condition
Derivation Path: 36.331 clause 6.2.2			
<i>MasterInformationBlock</i> ::= SEQUENCE {			
dl-Bandwidth	Downlink system bandwidth under test.		
phich-Config SEQUENCE {}	PHICH-Config-DEFAULT	See subclause 4.6.3	
systemFrameNumber	A valid value as defined in TS 36.331 [17]		
spare	'0000 0000 00'B		
}			

- *SystemInformation*

The *SystemInformation* message is used to convey one or more System Information Blocks. All the SIBs included are transmitted with the same periodicity.

Table 4.4.3.2-2: *SystemInformation*

Derivation Path: 36.331 clause 6.2.2			
Information Element	Value/remark	Comment	Condition
SystemInformation ::= SEQUENCE {			
criticalExtensions CHOICE {			
systemInformation-r8 SEQUENCE {			
sib-TypeAndInfo SEQUENCE (SIZE (1..maxSIB)) OF CHOICE {}	See subclause 4.4.3.1		
criticalExtensionsFuture SEQUENCE {}	Not present		
}			
}			
}			

- *SystemInformationBlockType1*

SystemInformationBlockType1 contains information relevant when evaluating if a UE is allowed to access a cell and defines the scheduling of other system information.

Table 4.4.3.2-3: *SystemInformationBlockType1*

Derivation Path: 36.331 clause 6.2.2			
Information Element	Value/remark	Comment	Condition
SystemInformationBlockType1 ::= SEQUENCE {			
cellAccessRelatedInfo SEQUENCE {			
plmn-IdentityList SEQUENCE (SIZE (1..6)) OF SEQUENCE {	1 entry		
plmn-Identity[1] SEQUENCE {			
mcc SEQUENCE (SIZE (3)) OF MCC-NMC-Digit	See table 4.4.2-2	For NAS test cases, see table 6.3.2.2-1.	
mnc SEQUENCE (SIZE (2..3)) OF MCC-NMC-Digit	See table 4.4.2-2	For NAS test cases, see table 6.3.2.2-1.	
}			
cellReservedForOperatorUse[1]	notReserved		
}			
trackingAreaCode	See table 4.4.2-2	For NAS test cases, see table 6.3.2.2-1.	
cellIdentity	Cell ID for the simulated cell		
cellBarred	notBarred		
intraFreqReselection	notAllowed		
csg-Indication	FALSE		
csg-Identity	Not present		
}			
cellSelectionInfo SEQUENCE {			
q-RxLevMin	-65 (-130 dBm)	For signalling test cases, see table 6.2.2.1-1.	
q-RxLevMinOffset	Not present		
}			
p-Max	Not present		
freqBandIndicator	Operating band under test.		
schedulingInfoList SEQUENCE (SIZE (1..maxSI-Message)) OF SEQUENCE {}	See subclause 4.4.3.1		
tdd-Config SEQUENCE {}	Not present		FDD
tdd-Config SEQUENCE {}	TDD-Config-DEFAULT	See subclause 4.6.3	TDD
si-WindowLength	ms20	To allow sufficient number of retransmissions.	
systemInfoValueTag	0		
nonCriticalExtension SEQUENCE {}	Not present		
}			

Condition	Explanation
FDD	FDD cell environment
TDD	TDD cell environment

4.4.3.3 Common contents of system information blocks

- *SystemInformationBlockType2*

The IE *SystemInformationBlockType2* contains radio resource configuration information that is common for all UEs.

Table 4.4.3.3-1: *SystemInformationBlockType2*

Derivation Path: 36.331 clause 6.3.1			
Information Element	Value/remark	Comment	Condition
SystemInformationBlockType2 ::= SEQUENCE {			
ac-BarringInfo SEQUENCE {}	Not present		
radioResourceConfigCommon SEQUENCE {}	RadioResourceCo nfigCommonSIB- DEFAULT	See subclause 4.6.3	
ue-TimersAndConstants SEQUENCE {			
t300	ms1000	Typical value in real network	
t301	ms1000	Typical value in real network	
t310	ms1000	Typical value in real network	
n310	n1		
t311	ms10000	Typical value in real network	
n311	n1		
}			
freqInfo SEQUENCE {			
ul-CarrierFreq	Not present	Default UL EARFCN applies	
ul-Bandwidth	Not Present		
additionalSpectrumEmission	1 (NS_01)	A-MPR doesn't apply by default. See TS 36.101 table 6.2.4-1.	
}			
mbsfn-SubframeConfiguration	Not present		
timeAlignmentTimerCommon	sf750	'sf750' is applicable to the widest range of mobility (up to about 360km/h).	
}			

- **SystemInformationBlockType3**

The IE *SystemInformationBlockType3* contains cell re-selection information common for intra-frequency, inter-frequency and/or inter-RAT cell re-selection (i.e. applicable for more than one type of cell re-selection but not necessarily all) as well as intra-frequency cell re-selection information other than neighbouring cell related.

Table 4.4.3.3-2: SystemInformationBlockType3

Derivation Path: 36.331 clause 6.3.1			
Information Element	Value/remark	Comment	Condition
SystemInformationBlockType3 ::= SEQUENCE {			
cellReselectionInfoCommon SEQUENCE {			
q-Hyst	dB0	To reduce interference between intra-frequency multiple cells	
speedStateReselectionPars SEQUENCE {}	Not present		
}			
cellReselectionServingFreqInfo SEQUENCE {			
s-NonIntraSearch	Not present		
threshServingLow	0 (0 dB)	Typical value in real network	
cellReselectionPriority	4	A middle value in the range has been selected.	
}			
intraFreqCellReselectionInfo SEQUENCE {			
q-RxLevMin	-70 (-140 dBm)	For signalling test cases, see table 6.2.2.1-1.	
p-Max	Not present		
s-IntraSearch	Not present		
allowedMeasBandwidth	Not present	The downlink bandwidth of the serving cell applies.	
presenceAntennaPort1	FALSE		
neighCellConfig	'01'B (No MBSFN subframes are present in all neighbour cells)	MBSFN doesn't apply by default.	
t-ReselectionEUTRA	0	Typical value in real network	
t-ReselectionEUTRA-SF	Not present		
}			
}			

- **SystemInformationBlockType4**

The IE *SystemInformationBlockType4* contains neighbouring cell related information relevant only for intra-frequency cell re-selection. The IE includes cells with specific re-selection parameters as well as blacklisted cells.

Table 4.4.3.3-3: SystemInformationBlockType4

Derivation Path: 36.331 clause 6.3.1			
Information Element	Value/remark	Comment	Condition
SystemInformationBlockType4 ::= SEQUENCE { intraFreqNeighCellList SEQUENCE (SIZE (1..maxCellIntra)) OF SEQUENCE {}	Not present	Not required unless Qoffset configuration is tested. When Qoffset configuration is tested, see table 6.3.1.1-1.	
intraFreqBlackCellList SEQUENCE (SIZE (1..maxCellBlack)) OF SEQUENCE {}	Not present	Not required unless Blacklisted cell list configuration is tested. When Blacklisted cell list configuration is tested, see table 6.3.1.1-1.	
csg-PhysCellIdRange	Not present		
}			

- **SystemInformationBlockType5**

The IE *SystemInformationBlockType5* contains information relevant only for inter-frequency cell re-selection i.e. information about other E-UTRA frequencies and inter-frequency neighbouring cells relevant for cell re-selection. The IE includes cell re-selection parameters common for a frequency as well as cell specific re-selection parameters.

Table 4.4.3.3-4: SystemInformationBlockType5

Derivation Path: 36.331 clause 6.3.1			
Information Element	Value/remark	Comment	Condition
SystemInformationBlockType5 ::= SEQUENCE { interFreqCarrierFreqList SEQUENCE (SIZE (1..maxFreq)) OF SEQUENCE {			
interFreqCarrierFreqList SEQUENCE (SIZE (1..maxFreq)) OF SEQUENCE {	The same number of entries as the configured inter-freq carriers For Signalling test cases except NAS, see table 6.3.1.2-1. For NAS test cases when cells are on same PLMN, see table 6.3.2.3.2-1.	n denotes the index of the entry	
dl-CarrierFreq[n]	Downlink EARFCN under test For Signalling test cases except NAS, see table 6.3.1.2-1. For NAS test cases when cells are on same PLMN, see table 6.3.2.3.2-1.		
q-RxLevMin[n]	-65 (-130 dBm)	For signalling test cases, see table 6.2.2.1-1.	
p-Max[n]	Not present		
t-ReselectionEUTRA[n]	0	Typical value in real network	
t-ReselectionEUTRA-SF[n]	Not present	Not required unless speed-dependent cell re-selection is tested.	
threshX-High[n]	2 (4 dB)	This value should be higher than threshServingLow of the serving cell to avoid ping-pong with lower priority cells.	
threshX-Low[n]	1 (2 dB)		
allowedMeasBandwidth[n]	See subclause 4.4.3.4	Channel-bandwidth-dependent parameter	
presenceAntennaPort1[n]	FALSE		
cellReselectionPriority[n]	4	The same priority as the one used for serving cell in SIB 3.	
neighCellConfig[n]	'01'B (No MBSFN subframes are present in all neighbour cells)	MBSFN doesn't apply by default.	
q-OffsetFreq[n]	dB0	Q_{offset} doesn't apply by default.	
interFreqNeighCellList[n] SEQUENCE (SIZE (1..maxCellInter)) OF SEQUENCE {}	Not present	Not required unless Q_{offset} configuration is tested.	
interFreqBlackCellList[n] SEQUENCE (SIZE (1..maxCellBlack)) OF SEQUENCE {}	Not present	Not required unless Blacklisted cell list configuration is tested.	
}			
}			

SystemInformationBlockType6

The IE *SystemInformationBlockType6* contains information relevant only for inter-RAT cell re-selection i.e. information about UTRA frequencies and UTRA neighbouring cells relevant for cell re-selection. The IE includes cell re-selection parameters common for a frequency.

Table 4.4.3.3-5: SystemInformationBlockType6

Derivation Path: 36.331 clause 6.3.1			
Information Element	Value/remark	Comment	Condition
SystemInformationBlockType6 ::= SEQUENCE {			
carrierFreqListUTRA-FDD SEQUENCE (SIZE (1..maxUTRA-FDD-Carrier)) OF SEQUENCE {	Not present		UTRA-TDD
carrierFreqListUTRA-FDD SEQUENCE (SIZE (1..maxUTRA-FDD-Carrier)) OF SEQUENCE {	The same number of entries as the configured UTRA FDD carriers For Signalling test cases, see table 6.3.1.3-1	<i>n</i> denotes the index of the entry	UTRA-FDD
carrierFreq[<i>n</i>]	Downlink UARFCN under test For Signalling test cases, see table 6.3.1.3-1		
cellReselectionPriority[<i>n</i>]	3		
threshX-High[<i>n</i>]	2 (4 dB)		
threshX-Low[<i>n</i>]	1 (2 dB)		
q-RxLevMin[<i>n</i>]	-40 (-79 dBm)	The same value as defined in TS 34.108 [5], table 6.1.1.	
p-MaxUTRA[<i>n</i>]	21 (21 dBm)	The same value as defined in TS 34.108 [5], table 6.1.1.	
q-QualMin[<i>n</i>]	-24 (-24 dB)	The same value as defined in TS 34.108 [5], table 6.1.1.	
}			
carrierFreqListUTRA-TDD SEQUENCE (SIZE (1..maxUTRA-TDD-Carrier)) OF SEQUENCE {	Not present		UTRA-FDD
carrierFreqListUTRA-TDD SEQUENCE (SIZE (1..maxUTRA-TDD-Carrier)) OF SEQUENCE {	The same number of entries as the configured UTRA TDD carriers For Signalling test cases, see table 6.3.1.3-1	<i>n</i> denotes the index of the entry	UTRA-TDD
carrierFreq[<i>n</i>]	Downlink UARFCN under test For Signalling test cases, see table 6.3.1.3-1		
cellReselectionPriority[<i>n</i>]	3		
threshX-High[<i>n</i>]	2 (4 dB)		
threshX-Low[<i>n</i>]	1 (2 dB)		
q-RxLevMin[<i>n</i>]	-41 (-81 dBm)	The same value as defined in TS 34.108 [5], table 6.1.6a	
p-MaxUTRA[<i>n</i>]	21 (21 dBm)	The same value as defined in TS 34.108 [5], table 6.1.6a	
}			
t-ReselectionUTRA	0	Typical value in real network	
t-ReselectionUTRA-SF	Not present		
}			

Condition	Explanation
UTRA-FDD	UTRA FDD cell environment
UTRA-TDD	UTRA TDD cell environment

Editor's note: Need for condition 'UTRA-FDD-TDD' where both UTRA FDD cell and UTRA TDD cell exist simultaneously is FFS.

- SystemInformationBlockType7

The IE *SystemInformationBlockType7* contains information relevant only for inter-RAT cell re-selection i.e. information about GERAN frequencies relevant for cell re-selection. The IE includes cell re-selection parameters for each frequency.

Table 4.4.3.3-6: SystemInformationBlockType7

Derivation Path: 36.331 clause 6.3.1			
Information Element	Value/remark	Comment	Condition
SystemInformationBlockType7 ::= SEQUENCE {			
t-ReselectionGERAN	0		
t-ReselectionGERAN-SFt-ReselectionGERAN-SF	Not present		
carrierFreqsInfoListcarrierFreqsInfoListSEQUENCE (SIZE (1..maxGNFG)) OF SEQUENCE {	The same number of entries as the configured GERAN carriers For Signalling test cases, see table 6.3.1.4-1	<i>n</i> denotes the index of the entry	
carrierFreqs carrierFreqs[<i>n</i>] SEQUENCE {			
startingARFCN[<i>n</i>]	Set the corresponding starting ARFCN of the GERAN cells under test. For Signalling test cases, see table 6.3.1.4-1		
bandIndicator[<i>n</i>]	Set according to the band used for GERAN cells under test		
followingARFCNs[<i>n</i>] CHOICE {			
explicitListOfARFCNs[<i>n</i>]	Set the corresponding ARFCN of GERAN cells under test For Signalling test cases, see table 6.3.1.4-1		
}			
}			
commonInfo[<i>n</i>] SEQUENCE {			
cellReselectionPriority[<i>n</i>]	2		
ncc-Permitted[<i>n</i>]	'11111111'B		
q-RxLevMin[<i>n</i>]	2		
p-MaxGERAN[<i>n</i>]	FFS	INTEGER (0..39) OPTIONAL	
threshX-High[<i>n</i>]	2		
threshX-Low[<i>n</i>]	2		
}			
}			
}			

- SystemInformationBlockType8

The IE *SystemInformationBlockType8* contains information relevant only for inter-RAT cell re-selection i.e. information about CDMA2000 frequencies and CDMA2000 neighbouring cells relevant for cell re-selection. The IE includes cell re-selection parameters common for a frequency as well as cell specific re-selection parameters.

Table 4.4.3.3-7: SystemInformationBlockType8

Derivation Path: 36.331 clause 6.3.1			
Information Element	Value/remark	Comment	Condition
SystemInformationBlockType8 ::= SEQUENCE {			
systemTimeInfo SEQUENCE {			
cdma-EUTRA-Synchronisation	TRUE		
cdma-SystemTime CHOICE {			
synchronousSystemTime	A valid value as per TS 36.331 and calculated by the SS		
}			
}			
searchWindowSize	5		
parametersHRPD SEQUENCE {}	Not present		1XRTT
parametersHRPD SEQUENCE {			HRPD
preRegistrationInfoHRPD SEQUENCE {			
preRegistrationAllowed	FALSE		
preRegistrationZoneId	Not present		
secondaryPreRegistrationZoneIdList SEQUENCE (SIZE (1..2)) OF SEQUENCE {	Set the number of entries according to specific test case		
PreRegistrationZoneIdHRPD	Set according to specific test case		
}			
}			
cellReselectionParametersHRPD SEQUENCE {			
bandClassList SEQUENCE (SIZE (1..maxCDMA -BandClass)) OF SEQUENCE {	1 entry		
bandClass	FFS	ENUMERATED {bc0, bc1, bc2, bc3, bc4, bc5, bc6, bc7, bc8, bc9, bc10, bc11, bc12, bc13, bc14, bc15, bc16, bc17, spare14, spare13, spare12, spare11, spare10, spare9, spare8, spare7, spare6, spare5, spare4, spare3, spare2, spare1, ...}	
cellReselectionPriority	1		
threshX-High	FFS	INTEGER (0..63)	
threshX-Low	FFS	INTEGER (0..63)	
}			
neighCellList SEQUENCE (SIZE (1..16)) OF SEQUENCE {	1 entry		
bandClass	FFS	ENUMERATED {bc0, bc1, bc2, bc3, bc4, bc5, bc6, bc7, bc8, bc9, bc10, bc11, bc12, bc13, bc14, bc15, bc16, bc17, spare14, spare13, spare12, spare11, spare10, spare9,	

		spare8, spare7, spare6, spare5, spare4, spare3, spare2, spare1, ...}	
neighCellsPerFreqList SEQUENCE (SIZE (1..16)) OF SEQUENCE {	The same number of entries as the configured CDMA2000 HRPD frequencies For Signalling test cases, see table 6.3.1.5-1	<i>n</i> denotes the index of the entry	
arfcn[<i>n</i>]	FFS For Signalling test cases, see table 6.3.1.5-1	INTEGER (0..2047)	
physCellIdList[<i>n</i>] SEQUENCE (SIZE (1..16)) OF {INTEGER (0..maxPNOffset) }	FFS For Signalling test cases, see table 6.3.1.5-1	INTEGER (0..maxPNOffset)	
}			
t-ReselectionCDMA2000	FFS	INTEGER (0..7)	
t-ReselectionCDMA2000-SF	Not Present		
}			
parameters1XRTT SEQUENCE {	Not present		HRPD
parameters1XRTT SEQUENCE {			1XRTT
csfb-RegistrationParam1XRTT SEQUENCE {			
sid	FFS	BIT STRING (SIZE (15))	
nid	FFS	BIT STRING (SIZE (16))	
multipleSID	FFS	BOOLEAN	
multipleNID	FFS	BOOLEAN	
homeReg	FFS	BOOLEAN	
foreignSIDReg	FFS	BOOLEAN	
foreignNIDReg	FFS	BOOLEAN	
parameterReg	FFS	BOOLEAN	
powerUpReg	FFS	BOOLEAN	
registrationPeriod	FFS	BIT STRING (SIZE (7))	
registrationZone	FFS	BIT STRING (SIZE (12))	
totalZone	FFS	BIT STRING (SIZE (3))	
zoneTimer	FFS	BIT STRING (SIZE (3))	
}			
longCodeState1XRTT	FFS	BIT STRING (SIZE (42)) OPTIONAL	
cellReselectionParameters1XRTT SEQUENCE {			
bandClassList SEQUENCE (SIZE (1..maxCDMA -BandClass)) OF SEQUENCE {	1 entry		
bandClass	FFS	ENUMERATED {bc0, bc1, bc2, bc3, bc4, bc5, bc6, bc7, bc8, bc9, bc10, bc11, bc12, bc13, bc14, bc15, bc16, bc17, spare14, spare13, spare12, spare11, spare10, spare9, spare8, spare7, spare6, spare5, spare4, spare3, spare2, spare1, ...}	

cellReselectionPriority	0		
threshX-High	FFS	INTEGER (0..63)	
threshX-Low	FFS	INTEGER (0..63)	
}			
neighCellList SEQUENCE (SIZE (1..16)) OF SEQUENCE {	1 entry		
bandClass	FFS	ENUMERATED {bc0, bc1, bc2, bc3, bc4, bc5, bc6, bc7, bc8, bc9, bc10, bc11, bc12, bc13, bc14, bc15, bc16, bc17, spare14, spare13, spare12, spare11, spare10, spare9, spare8, spare7, spare6, spare5, spare4, spare3, spare2, spare1, ...}	
neighCellsPerFreqList SEQUENCE (SIZE (1..16)) OF SEQUENCE {	The same number of entries as the configured CDMA2000 1xRTT frequencies For Signalling test cases, see table 6.3.1.6-1	<i>n</i> denotes the index of the entry	
arfcn[<i>n</i>]	FFS For Signalling test cases, see table 6.3.1.6-1	INTEGER (0..2047)	
physCellIdList[<i>n</i>] SEQUENCE (SIZE (1..16)) OF {INTEGER (0..maxPNOffset) }	FFS For Signalling test cases, see table 6.3.1.6-1	INTEGER (0..maxPNOffset)	
}			
}			
t-ReselectionCDMA2000	FFS	INTEGER (0..7)	
t-ReselectionCDMA2000-SF	Not Present		
}			
}			
}			

Condition	Explanation
HRPD	CDMA2000 HRPD cell environment
1XRTT	CDMA2000 1XRTT cell environment

Editor’s note: Need for condition ‘HRPD-1XRTT’ where both CDMA2000 HRPD cell and CDMA2000 1xRTT cell exist simultaneously is FFS.

- **SystemInformationBlockType9**

The IE *SystemInformationBlockType9* contains a home eNB name (HNB Name).

Table 4.4.3.3-8: SystemInformationBlockType9

Derivation Path: 36.331 clause 6.3.1			
Information Element	Value/remark	Comment	Condition
SystemInformationBlockType9 ::= SEQUENCE {	Set according to specific test case		

- **SystemInformationBlockType10**

The IE *SystemInformationBlockType10* contains an ETWS primary notification.

Table 4.4.3.3-9: SystemInformationBlockType10

Derivation Path: 36.331 clause 6.3.1			
Information Element	Value/remark	Comment	Condition
SystemInformationBlockType10 ::= SEQUENCE {}	Set according to specific test case		

- SystemInformationBlockType11

The IE *SystemInformationBlockType11* contains an ETWS secondary notification.

Table 4.4.3.3-10: SystemInformationBlockType11

Derivation Path: 36.331 clause 6.3.1			
Information Element	Value/remark	Comment	Condition
SystemInformationBlockType11 ::= SEQUENCE {}	Set according to specific test case		

4.4.3.4 Channel-bandwidth-dependent parameters in system information blocks

The default values of parameters in system information blocks which depend on the channel bandwidth are defined in table 4.4.3.4-1.

Table 4.4.3.4-1: Channel-bandwidth-dependent parameters

Information Element	Channel bandwidth						Comment
	1.4 MHz	3 MHz	5 MHz	10 MHz	15 MHz	20MHz	
SIB3 periodicity	64	64	32	32	32	32	
SIB4 periodicity	128	128	64	64	64	64	
SIB5 periodicity	128	128	64	64	64	64	
SIB6 periodicity	128	128	64	64	64	64	
SIB7 periodicity	128	128	64	64	64	64	
SIB8 periodicity	128	128	64	64	64	64	
measurement Bandwidth in SIB5	mbw6	mbw15	mbw25	mbw50	mbw75	mbw100	

4.4.4 Common parameters for simulated UTRA cells

The parameters specified in this subclause apply to all simulated UTRA cells unless otherwise specified.

Default UTRA parameters for simulated cells are specified in table 4.4.4-1 and table 4.4.4-2.

Other parameters are specified in TS 34.108 [5].

Table 4.4.4-1: Default parameters for simulated UTRA cells

cell ID	Primary scrambling code for FDD	Cell parameters ID for TDD
Cell 5	100	0
Cell 7	150	4
Cell 8	200	8
Cell 9	250	12

Table 4.4.4-2: Default NAS parameters for simulated UTRA cells

	PLMN		Location Area Identification		Routing Area Identification		TMSI	P-TMSI signature
	MCC	MNC	LA#	LAC	RA#	RAC		
Cell 5	(Note 1)		LAI-1	1	RAI-1	1	Arbitrarily selected according to TS 23.003 subclause 2.4 [2].	Arbitrarily selected according to TS 23.003 subclause 2.7 [2].
Cell 7	(Note 1)		LAI-1	1	RAI-1	1		
Cell 8	(Note 1)		LAI-1	1	RAI-1	1		
Cell 9	(Note 1)		LAI-1	1	RAI-1	1		
Note 1:	Set to the same Mobile Country Code and Mobile Network Code stored in EF _{MSI} on the test USIM card (subclause 4.9.3).							

4.4.4.1 Common contents of system information blocks for UTRA cells

- System Information Block type 19

The system information block type 19 contains Inter-RAT frequency and priority information to be used in the cell.

Table 4.4.4.1-1: System Information Block type 19

Derivation Path: 25.331 clause 11.3			
Information Element	Value/remark	Comment	Condition
SysInfoType19 ::= SEQUENCE {			
utra-PriorityInfoList SEQUENCE {			
utra-ServingCell SEQUENCE {			
priority	3		
s-PrioritySearch1	0 (0dB)		
s-PrioritySearch2	Not present	default value is 0	
threshServingLow	0 (0dB)		
}			
utran-FDD-FrequencyList SEQUENCE (SIZE(1..maxNumFDDFreqs)) OF SEQUENCE {}	Not present		
utran-TDD-FrequencyList SEQUENCE (SIZE(1..maxNumTDDFreqs)) OF SEQUENCE {}	Not present		
gsm-PriorityInfoList SEQUENCE (SIZE(1..maxNumGSMCellGroup)) OF SEQUENCE {}	Not present		
eutra-FrequencyAndPriorityInfoList SEQUENCE (SIZE(1..maxNumEUTRAFreqs)) OF SEQUENCE	The same number of entries as the configured eutra carriers For Signalling test cases, see table 6.3.1.7-1	<i>n</i> denotes the index of the entry	
earfcn[<i>n</i>]	Downlink EARFCN under test For Signalling test cases, see table 6.3.1.7-1		
measurementBandwidth[<i>n</i>]	See subclause 4.4.3.4		
priority[<i>n</i>]	4		
qRxLevMinEUTRA[<i>n</i>]	-65 (-130 dBm)		
threshXhigh[<i>n</i>]	2 (4 dB)		
threshXlow[<i>n</i>]	1 (2 dB)		
eutra-blackListedCellList[<i>n</i>]	Not present		
eutraDetection[<i>n</i>]	TRUE		
}			
nonCriticalExtensions SEQUENCE {}	Not present		
}			

4.4.4.2 UTRA SIB scheduling for inter EUTRA - UTRA test

Table 4.4.4.2-1: UTRA SIB schedule

Block Type	MIB	SB1	SIB1	SIB2	SIB3	SIB4	SIB5/SIB5bis	SIB6	SIB7	SIB11	SIB12	SIB18	SIB19

SIB_REP	8	16	64	64	64	64	64	64	16	64	64	64	64
SEG_COUNT	1	1	1	1	1	1	4	4	1	3	1	1	3

Table 4.4.4.2-2: UTRA SIB-repeat period

Frame No / SIB_POS	0	2	4	6	8	10	12	14
Block Type	MIB	SB1	SIB7	SIB6	MIB	SIB6	SIB6	SIB6
Frame No / SIB_POS	16	18	20	22	24	26	28	30
Block Type	MIB	SB1	SIB7/SIB3	SIB1/SIB2	MIB	SIB12/SIB19	SIB19	SIB19
Frame No / SIB_POS	32	34	36	38	40	42	44	46
Block Type	MIB	SB1	SIB7/SIB18	SIB5/SIB5bis	MIB	SIB5/SIB5bis	SIB5/SIB5bis	SIB5/SIB5bis
Frame No / SIB_POS	48	50	52	54	56	58	60	62
Block Type	MIB	SB1	SIB7/SIB4	-	MIB	SIB11	SIB11	SIB11

4.4.4.3 UTRA SIB scheduling for inter EUTRA – UTRA - GERAN test

Table 4.4.4.3-1: UTRA SIB schedule

Block Type	MIB	SB1	SIB1	SIB2	SIB3	SIB4	SIB5/SIB5bis	SIB7	SIB11	SIB16	SIB18	SIB19
SIB Rep	8	16	128	128	64	64	128	32	128	128	128	128
Max. No of seg.	1	2	1	1	1	1	4	1	3	8	1	3

Table 4.4.4.3-2: UTRA SIB-repeat period

Frame No / SIB_POS	0	2	4	6	8	10	12	14
Block Type	MIB	SB1	SB1	SIB19	MIB	SIB1	SIB18	SIB2
Frame No / SIB_POS	16	18	20	22	24	26	28	30
Block Type	MIB	SB1	SB1	SIB7	MIB	SIB3	SIB19	SIB4
Frame No / SIB_POS	32	34	36	38	40	42	44	46
Block Type	MIB	SB1	SB1	SIB5/ SIB5bis	MIB	SIB5/ SIB5bis	SIB5/ SIB5bis	SIB5/ SIB5bis
Frame No / SIB_POS	48	50	52	54	56	58	60	62
Block Type	MIB	SB1	SB1	SIB7	MIB	SIB11	SIB11	SIB11
Frame No / SIB_POS	64	66	68	70	72	74	76	78
Block Type	MIB	SB1	SB1	SIB16	MIB	SIB16	SIB16	SIB16
Frame No / SIB_POS	80	82	84	86	88	90	92	94
Block Type	MIB	SB1	SB1	SIB7	MIB	SIB3	SIB19	SIB4
Frame No / SIB_POS	96	98	100	102	104	106	108	110
Block Type	MIB	SB1	SB1	SIB16	MIB	SIB16	SIB16	SIB16
Frame No / SIB_POS	112	114	116	118	120	122	124	126
Block Type	MIB	SB1	SB1	SIB7	MIB			

4.4.5 Common parameters for simulated GERAN cells

The parameters specified in this subclause apply to all simulated GERAN cells unless otherwise specified.

See TS 51.010 [25].

4.4.6 Common parameters for simulated CDMA2000 cells

The parameters specified in this subclause apply to all simulated HRPD or 1xRTT cells unless otherwise specified.

See C.S0038-A [36] for HRPD cells and C.S0043-0 [37] for 1xRTT cells.

4.4.7 Default parameters specific for simulated cells

Default parameters specific for simulated cells are specified in this subclause.

Editor's Note: This section is reserved for cell specific default parameters.

4.5 Generic procedures

This clause describes UE test states which can be used in the initial condition of many test cases defined in TS 36.521-1 [21], TS 36.523-1 [18] and TS 36.523-3 [34] or other procedures defined in this specification. This section also defines a set of procedures to bring the UE into these states.

4.5.1 UE test states

NOTE: The need to have a procedure for the transition from State 4/State 3 to State 2 is for further study and it can added if the technical motivation for this procedure can be justified.

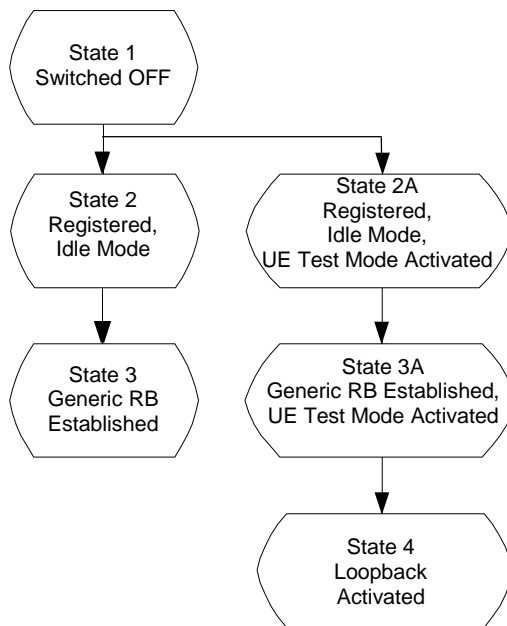

Figure 4.5.1-1: UE Test States for Basic Generic Procedures

In order that the UE can set up a call or session in E-UTRAN, there are a number of procedures to be undertaken in a hierachical sequence to move between known states. The sequences are shown in figure 4.5.1-1 and the status of the relevant protocols in the UE in the different states are given in table 4.5.1-1.

Table 4.5.1-1: The UE states

		RRC	ECM	EMM	ESM	UE Test Mode
State 1	Switched OFF	-----	-----	-----	-----	-----
State 2	Registered, Idle Mode	RRC_IDLE	ECM-IDLE	EMM-REGISTERED	1 default EPS bearer context active.	Not active
State 2A	Registered, Idle Mode, UE Test Mode Activated	RRC_IDLE	ECM-IDLE	EMM-REGISTERED	1 default EPS bearer context active.	Active
State 3	Generic RB Established	RRC_CONNECTED 1 + N (0 ≤ N ≤ 7) data radio bearers configured as specified in the test cases	ECM-CONNECTED	EMM-REGISTERED	1 default EPS bearer context active and N (0 ≤ N ≤ 7) dedicated EPS bearers active as specified in the test cases	Not active
State 3A	Generic RB Established, UE Test Mode Activated	RRC_CONNECTED 1 + N (0 ≤ N ≤ 7) data radio bearers configured as specified in the test cases	ECM-CONNECTED	EMM-REGISTERED	1 default EPS bearer context active and N (0 ≤ N ≤ 7) dedicated EPS bearers active as specified in the test cases	Active
State 4	Loopback Activated	RRC_CONNECTED 1 + N (0 ≤ N ≤ 7) data radio bearers configured as specified in the test cases	ECM-CONNECTED	EMM-REGISTERED	1 default EPS bearer context active and N (0 ≤ N ≤ 7) dedicated EPS bearers active as specified in the test cases	Active

NOTE: Refer to TS 24.301 [28] subclause 5.5.1.1 for more details on the ESM state.

NOTE: Refer to TS 36.509 [38] for details regarding UE test mode and UE Loopback.

4.5.2 UE Registration (State 2)

4.5.2.1 Initial conditions

System Simulator:

- 1 cell, default parameters.
- The procedure shall be performed under ideal radio conditions as defined in clause 5

User Equipment:

- The Test USIM shall be inserted.

4.5.2.2 Definition of system information messages

The default system information messages are used.

4.5.2.3 Procedure

Table 4.5.2.3-1: UE registration procedure (state 1 to state 2)

Step	Procedure	Message Sequence	
		U - S	Message
1		<--	RRC: SYSTEM INFORMATION (BCCH)
2	UE transmits an <i>RRCConnectionRequest</i> message.	-->	RRC: <i>RRCConnectionRequest</i>
3	SS transmit a <i>RRCConnectionSetup</i> message.	<--	RRC: <i>RRCConnectionSetup</i>
4	The UE transmits a <i>RRCConnectionSetupComplete</i> message to confirm the successful completion of the connection establishment and to initiate the Attach procedure by including the ATTACH REQUEST message. The PDN CONNECTIVITY REQUEST message is piggybacked in ATTACH REQUEST	-->	RRC: <i>RRCConnectionSetupComplete</i> NAS: ATTACH REQUEST NAS: PDN CONNECTIVITY REQUEST
5	The SS transmits an AUTHENTICATION REQUEST message to initiate the EPS authentication and AKA procedure.	<--	RRC: <i>DLInformationTransfer</i> NAS: AUTHENTICATION REQUEST
6	The UE transmits an AUTHENTICATION RESPONSE message and establishes mutual authentication.	-->	RRC: <i>ULInformationTransfer</i> NAS: AUTHENTICATION RESPONSE
7	The SS transmits a NAS SECURITY MODE COMMAND message to activate NAS security.	<--	RRC: <i>DLInformationTransfer</i> NAS: SECURITY MODE COMMAND
8	The UE transmits a NAS SECURITY MODE COMPLETE message and establishes the initial security configuration.	-->	RRC: <i>ULInformationTransfer</i> NAS: SECURITY MODE COMPLETE
-	EXCEPTION: Steps 9a1 to 9a2 describe behaviour that depends on UE configuration; the "lower case letter" identifies a step sequence that take place if the UE has ESM information which needs to be transferred after NAS SECURITY MODE COMPLETE message.	-	-
9a1	IF the UE sets the ESM information transfer flag in the last PDN CONNECTIVITY REQUEST message THEN the SS transmits an ESM INFORMATION REQUEST message to initiate exchange of protocol configuration options.	<--	RRC: <i>DLInformationTransfer</i> NAS: ESM INFORMATION REQUEST
9a2	The UE transmits an ESM INFORMATION RESPONSE message to transfer protocol configuration options.	-->	RRC: <i>ULInformationTransfer</i> NAS: ESM INFORMATION RESPONSE
10	The SS transmits a <i>SecurityModeCommand</i> message to activate AS security.	<--	RRC: <i>SecurityModeCommand</i>
11	The UE transmits a <i>SecurityModeComplete</i> message and establishes the initial security configuration.	-->	RRC: <i>SecurityModeComplete</i>
12	The SS transmits an <i>UECapabilityEnquiry</i> message to initiate the UE radio access capability transfer procedure.	<--	RRC: <i>UECapabilityEnquiry</i>
13	The UE transmits an <i>UECapabilityInformation</i> message to transfer UE radio access capability.	-->	RRC: <i>UECapabilityInformation</i>
14	The SS transmits a <i>RRCConnectionReconfiguration</i> message to establish the default bearer with condition SRB2-DRB(1, 0) according to 4.8.2.2.1.1. This message includes the ATTACH ACCEPT message. The ACTIVATE DEFAULT EPS BEARER CONTEXT REQUEST message is piggybacked in ATTACH ACCEPT.	<--	RRC: <i>RRCConnectionReconfiguration</i> NAS: ATTACH ACCEPT NAS: ACTIVATE DEFAULT EPS BEARER CONTEXT REQUEST
15	The UE transmits a	-->	RRC:

	<i>RRCConnectionReconfigurationComplete</i> message to confirm the establishment of default bearer.		<i>RRCConnectionReconfigurationComplete</i>
16	This message includes the ATTACH COMPLETE message. The ACTIVATE DEFAULT EPS BEARER CONTEXT ACCEPT message is piggybacked in ATTACH COMPLETE.	-->	RRC: <i>ULInformationTransfer</i> NAS: ATTACH COMPLETE NAS: ACTIVATE DEFAULT EPS BEARER CONTEXT ACCEPT
17	The SS transmits a <i>RRCConnectionRelease</i> message to release RRC connection and move to RRC_IDLE (State 2).	<--	RRC: <i>RRCConnectionRelease</i>

NOTE: If a test case needs to force the UE to attach to EPS services only regardless of UE mode of operation, use the condition "EPSONlyAttachForced" in its preamble, which is defined below the table 4.7.2-1.

4.5.2.4 Specific message contents

All specific message contents shall be referred to clause 4.6 and 4.7 with the exceptions below.

Table 4.5.2.4-1: *RRCConnectionRequest* (Step 2)

Derivation Path: Table 4.6.1-16			
Information Element	Value/remark	Comment	Condition
<i>RRCConnectionRequest</i> ::= SEQUENCE {			
criticalExtensions CHOICE {			
rrcConnectionRequest-r8 SEQUENCE {			
ue-Identity	Any allowed value		
}			
}			
}			

Table 4.5.2.4-2: *UECapabilityInformation* (Step 12)

Derivation Path: Table 4.6.1-23			
Information Element	Value/remark	Comment	Condition
<i>UECapabilityInformation</i> ::= SEQUENCE {			
criticalExtensions CHOICE {			
c1 CHOICE{			
ueCapabilityInformation-r8	Any allowed value		
}			
}			
}			

4.5.2A UE Registration, UE Test Mode Activated (State 2A)

4.5.2A.1 Initial conditions

System Simulator:

- 1 cell, default parameters.
- The procedure shall be performed under ideal radio conditions as defined in clause 5

User Equipment:

- The Test USIM shall be inserted.

4.5.2A.2 Definition of system information messages

The default system information messages are used.

4.5.2A.3 Procedure

Table 4.5.2A.3-1: UE registration with test mode activation procedure (state 1 to state 2A)

Step	Procedure	Message Sequence	
		U - S	Message
1 to 9a2	Same procedure for steps 1 to 9a2 as specified in the procedure in clause 4.5.2.3	-	-
10	The SS transmits an ACTIVATE TEST MODE message to activate UE radio bearer test mode procedure.	<--	RRC: <i>DLInformationTransfer</i> TC: ACTIVATE TEST MODE
11	The UE transmits an ACTIVATE TEST MODE COMPLETE message.	-->	RRC: <i>ULInformationTransfer</i> TC: ACTIVATE TEST MODE COMPLETE
12	The SS transmits a <i>SecurityModeCommand</i> message to activate AS security.	<--	RRC: <i>SecurityModeCommand</i>
13	The UE transmits a <i>SecurityModeComplete</i> message and establishes the initial security configuration.	-->	RRC: <i>SecurityModeComplete</i>
14	The SS transmits an <i>UECapabilityEnquiry</i> message to initiate the UE radio access capability transfer procedure.	<--	RRC: <i>UECapabilityEnquiry</i>
15	The UE transmits an <i>UECapabilityInformation</i> message to transfer UE radio access capability.	-->	RRC: <i>UECapabilityInformation</i>
16	The SS transmits a <i>RRCCConnectionReconfiguration</i> message to establish the default bearer with condition SRB2-DRB(1, 0) according to 4.8.2.2.1.1. This message includes the ATTACH ACCEPT message. The ACTIVATE DEFAULT EPS BEARER CONTEXT REQUEST message is piggybacked in ATTACH ACCEPT.	<--	RRC: <i>RRCCConnectionReconfiguration</i> NAS: ATTACH ACCEPT NAS: ACTIVATE DEFAULT EPS BEARER CONTEXT REQUEST
17	The UE transmits a <i>RRCCConnectionReconfigurationComplete</i> message to confirm the establishment of default bearer.	-->	RRC: <i>RRCCConnectionReconfigurationComplete</i>
18	This message includes the ATTACH COMPLETE message. The ACTIVATE DEFAULT EPS BEARER CONTEXT ACCEPT message is piggybacked in ATTACH COMPLETE.	-->	RRC: <i>ULInformationTransfer</i> NAS: ATTACH COMPLETE NAS: ACTIVATE DEFAULT EPS BEARER CONTEXT ACCEPT
19	The SS transmits a <i>RRCCConnectionRelease</i> message to release RRC connection and move to RRC_IDLE (State 2A).	<--	RRC: <i>RRCCConnectionRelease</i>

NOTE: If a test case needs to force the UE to attach to EPS services only regardless of UE mode of operation, use the condition "EPSONlyAttachForced" in its preamble, which is defined below the table 4.7.2-1.

4.5.2A.4 Specific message contents

All specific message contents shall be referred to clause 4.6, 4.7 and 4.7A with the exceptions below.

Table 4.5.2A.4-1: *RRCCConnectionRequest* (Step 2)

Derivation Path: Table 4.6.1-16			
Information Element	Value/remark	Comment	Condition
<i>RRCCConnectionRequest</i> ::= SEQUENCE {			
criticalExtensions CHOICE {			
<i>rrcConnectionRequest-r8</i> SEQUENCE {			
ue-Identity	Any allowed value		
}			
}			
}			

Table 4.5.2A.4-2: *UECapabilityInformation* (Step 12)

Derivation Path: Table 4.6.1-23			
Information Element	Value/remark	Comment	Condition
UECapabilityInformation ::= SEQUENCE {			
criticalExtensions CHOICE {			
c1 CHOICE{			
ueCapabilityInformation-r8	Any allowed value		
}			
}			
}			

4.5.3 Generic Radio Bearer Establishment (State 3)

Editor note: The default parameter and system information will depend on progress in Clause 4.4, once it is finalised RAN5 can refer to them accordingly.

4.5.3.1 Initial conditions

System Simulator:

- Parameters are set to the default parameters for the basic single cell environment, as defined in subclause 4.4, unless otherwise specified in the test case.

User Equipment:

- The UE shall be in Registered, Idle Mode state (State 2).

4.5.3.2 Definition of system information messages

The default system information messages are used.

4.5.3.3 Procedure

The establishment of generic radio bearer connection is assumed to always be mobile terminated.

Editor's note: the need for a mobile originated procedure is FFS (use case needed)

Table 4.5.3.3-1: Generic Radio Bearer establishment procedure (state 2 to state 3)

Step	Procedure	U - S	Message Sequence Message
1		<--	RRC: SYSTEM INFORMATION (BCCH)
2	SS sends a <i>Paging</i> message to the UE on the appropriate paging block, and including the UE identity in one entry of the IE <i>pagingRecordLists</i> .	<--	RRC: <i>Paging</i> (PCCH)
3	UE transmits an <i>RRCConnectionRequest</i> message.	-->	RRC: <i>RRCConnectionRequest</i>
4	SS transmit a <i>RRCConnectionSetup</i> message.	<--	RRC: <i>RRCConnectionSetup</i>
5	The UE transmits a <i>RRCConnectionSetupComplete</i> message to confirm the successful completion of the connection establishment and to initiate the session management procedure by including the SERVICE REQUEST message. (State3)	-->	RRC: <i>RRCConnectionSetupComplete</i> NAS: SERVICE REQUEST
6	The SS transmits a <i>SecurityModeCommand</i> message to activate AS security.	<--	RRC: <i>SecurityModeCommand</i>
7	The UE transmits a <i>SecurityModeComplete</i> message and establishes the initial security configuration.	-->	RRC: <i>SecurityModeComplete</i>
8	The SS configures a new data radio bearer, associated with the default EPS bearer context. IF the test case using state 3 as an initial state is using N additional data radio bearers ($0 \leq N \leq 7$), the <i>RRCConnectionReconfiguration</i> message contains the configuration of these additional data radio bearers in the drb-ToAddModify IE and one ACTIVATE DEDICATED EPS BEARER CONTEXT REQUEST message per additional data radio bearer. The <i>RRCConnectionReconfiguration</i> message is using condition SRB2-DRB(1+n, m) where n and m are the number of DRBs associated with dedicated EPS bearer contexts and configured respectively with RLC-AM and RLC-UM ($n+m = N$).	<--	RRC: <i>RRCConnectionReconfiguration</i> NAS: ACTIVATE DEDICATED EPS BEARER CONTEXT REQUEST ... ACTIVATE DEDICATED EPS BEARER CONTEXT REQUEST
-	EXCEPTION: the steps 9 and 10a1 to 10a3 (if present) happen in any order.	-	-
9	The UE transmits a <i>RRCConnectionReconfigurationComplete</i> message to confirm the establishment of the new data radio bearer, associated with the default EPS bearer context.	-->	RRC: <i>RRCConnectionReconfigurationComplete</i>
10a1	IF $N \geq 1$ (see step 8), the UE transmits an ACTIVATE DEDICATED EPS BEARER CONTEXT ACCEPT message matching with the 1st ACTIVATE DEDICATED EPS BEARER CONTEXT REQUEST message included in step 8.	-->	RRC: ULInformationTransfer NAS: ACTIVATE DEDICATED EPS BEARER CONTEXT ACCEPT
10a2	IF $N \geq 2$ (see step 8), the UE transmits an ACTIVATE DEDICATED EPS BEARER CONTEXT ACCEPT message matching with the 2nd ACTIVATE DEDICATED EPS BEARER CONTEXT REQUEST message included in step 8.	-->	RRC: ULInformationTransfer NAS: ACTIVATE DEDICATED EPS BEARER CONTEXT ACCEPT

10a3	IF $N \geq 3$ (see step 8), the UE transmits an ACTIVATE DEDICATED EPS BEARER CONTEXT ACCEPT message matching with the 3rd ACTIVATE DEDICATED EPS BEARER CONTEXT REQUEST message included in step 8.	-->	RRC: ULInformationTransfer NAS: ACTIVATE DEDICATED EPS BEARER CONTEXT ACCEPT
10a4	IF $N \geq 4$ (see step 8), the UE transmits an ACTIVATE DEDICATED EPS BEARER CONTEXT ACCEPT message matching with the 4th ACTIVATE DEDICATED EPS BEARER CONTEXT REQUEST message included in step 8.	-->	RRC: ULInformationTransfer NAS: ACTIVATE DEDICATED EPS BEARER CONTEXT ACCEPT
10a5	IF $N \geq 5$ (see step 8), the UE transmits an ACTIVATE DEDICATED EPS BEARER CONTEXT ACCEPT message matching with the 5th ACTIVATE DEDICATED EPS BEARER CONTEXT REQUEST message included in step 8.	-->	RRC: ULInformationTransfer NAS: ACTIVATE DEDICATED EPS BEARER CONTEXT ACCEPT
10a6	IF $N \geq 6$ (see step 8), the UE transmits an ACTIVATE DEDICATED EPS BEARER CONTEXT ACCEPT message matching with the 6th ACTIVATE DEDICATED EPS BEARER CONTEXT REQUEST message included in step 8.	-->	RRC: ULInformationTransfer NAS: ACTIVATE DEDICATED EPS BEARER CONTEXT ACCEPT
10a7	IF $N = 7$ (see step 8), the UE transmits an ACTIVATE DEDICATED EPS BEARER CONTEXT ACCEPT message matching with the 7th ACTIVATE DEDICATED EPS BEARER CONTEXT REQUEST message included in step 8.	-->	RRC: ULInformationTransfer NAS: ACTIVATE DEDICATED EPS BEARER CONTEXT ACCEPT

4.5.3.4 Specific message contents

All specific message contents shall be referred to clause 4.6 and 4.7.

4.5.3A Generic Radio Bearer Establishment, UE Test Mode Activated (State 3A)

Editor note: The default parameter and system information will depend on progress in Clause 4.4, once it is finalised RAN5 can refer to them accordingly.

4.5.3A.1 Initial conditions

System Simulator:

- Parameters are set to the default parameters for the basic single cell environment, as defined in subclause 4.4, unless otherwise specified in the test case.

User Equipment:

- The UE shall be in Registered, Idle Mode state, UE Test Mode Activated (State 2A).

4.5.3A.2 Definition of system information messages

The default system information messages are used.

4.5.3A.3 Procedure

Same procedure as specified in the procedure in clause 4.5.3.3.

4.5.3A.4 Specific message contents

All specific message contents shall be referred to clause 4.6, 4.7 and 4.7A.

4.5.4 Loopback Activation (State 4)

4.5.4.1 Initial conditions

System Simulator:

- Parameters are set to the default parameters for the basic single cell environment, as defined in subclause 4.4, unless otherwise specified in the test case.

User Equipment:

- The UE shall be in Generic RB Establishment state, UE Test Mode Activated (State 3A).

4.5.4.2 Definition of system information messages

The default system information messages are used.

4.5.4.3 Procedure

Table 4.5.3.3-1: Loopback activation procedure (state 3A to state 4)

Step	Procedure	Direction	Message Sequence
		UE - SS	Message
1	The SS transmits a CLOSE UE TEST LOOP message to enter the UE test loop mode.	<--	RRC: <i>DLInformationTransfer</i> TC: CLOSE UE TEST LOOP
2	The UE transmits a CLOSE UE TEST LOOP COMPLETE message to confirm that loopback entities for the radio bearer(s) have been created and loop back is activated (State 4).	-->	RRC: <i>ULInformationTransfer</i> TC: CLOSE UE TEST LOOP COMPLETE

4.5.4.4 Specific message contents

All specific message contents shall be referred to clause 4.6 and 4.7A.

4.6 Default RRC message and information elements contents

This clause contains the default values of common RRC messages and information elements, which unless indicated otherwise in specific clauses of TS 36.521-1 [21], TS 36.521-3 [34], TS 36.523-1 [18] and other clauses in this specification. All the messages and information elements are listed in alphabetical order.

4.6.1 Contents of RRC messages

– *CounterCheck*

Table 4.6.1-0a: CounterCheck

Derivation Path: 36.331 clause 6.2.2			
Information Element	Value/remark	Comment	Condition
CounterCheck ::= SEQUENCE {			
rrc-TransactionIdentifier	RRC-TransactionIdentifier-DL		
criticalExtensions CHOICE {			
c1 CHOICE {			
counterCheck-r8 SEQUENCE {			
drb-CountMSB-InfoList	Set according to specific message content		
nonCriticalExtension SEQUENCE {}	Not present		
}			
}			
}			
}			

– *CounterCheckResponse*

Table 4.6.1-0b: CounterCheckResponse

Derivation Path: 36.331 clause 6.2.2			
Information Element	Value/remark	Comment	Condition
CounterCheckResponse ::= SEQUENCE {			
rrc-TransactionIdentifier	RRC-TransactionIdentifier-UL		
criticalExtensions CHOICE {			
counterCheckResponse-r8 SEQUENCE {			
drb-CountInfoList	Set according to specific message content		
nonCriticalExtension SEQUENCE {}	Not checked		
}			
}			
}			

– *CSFBParametersRequestCDMA2000*

Table 4.6.1-1: CSFBParametersRequestCDMA2000

Derivation Path: 36.331 clause 6.2.2			
Information Element	Value/remark	Comment	Condition
CSFBParametersRequestCDMA2000 ::= SEQUENCE {			
criticalExtensions CHOICE {			
csfbParametersRequestCDMA2000-r8 SEQUENCE {			
nonCriticalExtension SEQUENCE {}	Not checked		
}			
}			
}			

– *CSFBParametersResponseCDMA2000***Table 4.6.1-2: CSFBParametersResponseCDMA2000**

Derivation Path: 36.331 clause 6.2.2			
Information Element	Value/remark	Comment	Condition
CSFBParametersResponseCDMA2000 ::= SEQUENCE {			
rrc-TransactionIdentifier	RRC-TransactionIdentifier-DL		
criticalExtensions CHOICE {			
csfbParametersResponseCDMA2000-r8 SEQUENCE {			
rand	Set according to specific message content		
mobilityParameters	Set according to specific message content		
nonCriticalExtension SEQUENCE {}	Not present		
}			
}			
}			

– *DLInformationTransfer***Table 4.6.1-3: DLInformationTransfer**

Derivation Path: 36.331 clause 6.2.2			
Information Element	Value/remark	Comment	Condition
DLInformationTransfer ::= SEQUENCE {			
rrc-TransactionIdentifier	RRC-TransactionIdentifier-DL		
criticalExtensions CHOICE {			
c1 CHOICE {			
dlInformationTransfer-r8 SEQUENCE {			
dedicatedInfoType CHOICE {			
dedicatedInfoNAS	Set according to specific message content		
}			
nonCriticalExtension SEQUENCE {}	Not present		
}			
}			
}			

– *HandoverFromEUTRAPreparationRequest***Table 4.6.1-4: HandoverFromEUTRAPreparationRequest**

Derivation Path: 36.331 clause 6.2.2			
Information Element	Value/remark	Comment	Condition
HandoverFromEUTRAPreparationRequest ::= SEQUENCE {			
rrc-TransactionIdentifier	RRC-TransactionIdentifier-DL		
criticalExtensions CHOICE {			
c1 CHOICE {			
handoverFromEUTRAPreparationRequest-r8 SEQUENCE {			
cdma2000-Type	type1XRTT		
rand	A random value, generated by the SS		
mobilityParameters	Set according to specific message content		
nonCriticalExtension SEQUENCE {}	Not present		
}			
}			
}			
}			

– *MeasurementReport***Table 4.6.1-5: MeasurementReport**

Derivation Path: 36.331 clause 6.2.2			
Information Element	Value/remark	Comment	Condition
MeasurementReport ::= SEQUENCE {			
criticalExtensions CHOICE {			
c1 CHOICE {			
measurementReport-r8 SEQUENCE {			
measResults	Set according to specific message content		
nonCriticalExtension SEQUENCE {}	Not checked		
}			
}			
}			
}			

– *MobilityFromEUTRACommand***Table 4.6.1-6: *MobilityFromEUTRACommand***

Derivation Path: 36.331 clause 6.2.2			
Information Element	Value/remark	Comment	Condition
MobilityFromEUTRACommand ::= SEQUENCE {			
rrc-TransactionIdentifier	RRC-TransactionIdentifier-DL		
criticalExtensions CHOICE {			
c1 CHOICE {			
mobilityFromEUTRACommand-r8 SEQUENCE {			
csFallbackIndicator	Set according to specific message content		
purpose CHOICE {	Set according to specific message content		
handover			
cellChangeOrder			
}			
nonCriticalExtension SEQUENCE {}	Not present		
}			
}			
}			

– *Paging***Table 4.6.1-7: *Paging***

Derivation Path: 36.331 clause 6.2.2			
Information Element	Value/remark	Comment	Condition
Paging ::= SEQUENCE {			
pagingRecordList SEQUENCE (SIZE (1..maxPageRec)) OF SEQUENCE {	1 entry		
ue-Identity[1] CHOICE {			
s-TMSI	Set to the value of the S-TMSI of the UE		
}			
cn-Domain[1]	ps		
}			
systemInfoModification	Not present		
etws-Indication	Not present		
nonCriticalExtension SEQUENCE {}	Not present		
}			

– *RRCConnectionReconfiguration***Table 4.6.1-8: RRCConnectionReconfiguration**

Derivation Path: 36.331 clause 6.2.2			
Information Element	Value/remark	Comment	Condition
RRCConnectionReconfiguration ::= SEQUENCE {			
rrc-TransactionIdentifier	RRC-TransactionIdentifier-DL		
criticalExtensions CHOICE {			
c1 CHOICE{			
rrcConnectionReconfiguration-r8 SEQUENCE {			
measConfig	Not present		
	MeasConfig-DEFAULT		MEAS
mobilityControllInfo	Not present		
	MobilityControllInfo-HO		HO
dedicatedInfoNASList	Not present		
	Set according to specific message content		SRB2-DRB(n, m) DRB(n, m) SRB1-SRB2-DRB(n,m)
radioResourceConfigDedicated	Not present		
	RadioResourceConfigDedicated-SRB2-DRB(n, m)		SRB2-DRB(n, m)
	RadioResourceConfigDedicated-DRB(n, m)		DRB(n, m)
	RadioResourceConfigDedicated-SRB1-SRB2-DRB(n, m)		SRB1-SRB2-DRB(n,m)
	RadioResourceConfigDedicated-HO		HO
securityConfigHO	Not present		
	SecurityConfigHO-DEFAULT		HO
nonCriticalExtension SEQUENCE {}	Not present		
}			
}			
}			
}			

Condition	Explanation
SRB2-DRB(n,m)	Establishment of a SRB and DRB combination with n x AM DRB and m x UM DRB (including establishment of SRB2)
DRB(n,m)	Establishment of additional n x AM DRB:s and m x UM DRB:s (SRB2 should already be established)
SRB1-SRB2-DRB(n,m)	Establishment of a SRB and DRB combination with n x AM DRB and m x UM DRB (including establishment of SRB1 and SRB2)
HO	Intra LTE handover
MEAS	A measurement is configured

– *RRCConnectionReconfigurationComplete*

Table 4.6.1-9: RRCConnectionReconfigurationComplete

Derivation Path: 36.331 clause 6.2.2			
Information Element	Value/remark	Comment	Condition
RRCConnectionReconfigurationComplete ::= SEQUENCE {			
rrc-TransactionIdentifier	RRC-TransactionIdentifier-UL		
criticalExtensions CHOICE {			
rrcConnectionReconfigurationComplete-r8			
SEQUENCE {			
nonCriticalExtension SEQUENCE {}	Not checked		
}			
}			
}			

– *RRCConnectionReestablishment*

Table 4.6.1-10: RRCConnectionReestablishment

Derivation Path: 36.331 clause 6.2.2			
Information Element	Value/remark	Comment	Condition
RRCConnectionReestablishment ::= SEQUENCE {			
rrc-TransactionIdentifier	RRC-TransactionIdentifier-DL		
criticalExtensions CHOICE {			
c1 CHOICE{			
rrcConnectionReestablishment-r8 SEQUENCE			
}			
radioResourceConfigDedicated	RadioResourceConfigDedicated-SRB1		
nextHopChainingCount	0		
nonCriticalExtension SEQUENCE {}	Not present		
}			
}			
}			
}			

– *RRCConnectionReestablishmentComplete*

Table 4.6.1-11: RRCConnectionReestablishmentComplete

Derivation Path: 36.331 clause 6.2.2			
Information Element	Value/remark	Comment	Condition
RRCConnectionReestablishmentComplete ::= SEQUENCE {			
rrc-TransactionIdentifier	RRC-TransactionIdentifier-UL		
criticalExtensions CHOICE {			
rrcConnectionReestablishmentComplete-r8			
SEQUENCE {			
nonCriticalExtension SEQUENCE {}	Not checked		
}			
}			
}			

– *RRCCONNECTIONREESTABLISHMENTREJECT*

Table 4.6.1-12: RRCCONNECTIONREESTABLISHMENTREJECT

Derivation Path: 36.331 clause 6.2.2			
Information Element	Value/remark	Comment	Condition
RRCCONNECTIONREESTABLISHMENTREJECT ::= SEQUENCE {			
criticalExtensions CHOICE {			
rrcConnectionReestablishmentReject-r8			
SEQUENCE {			
nonCriticalExtension SEQUENCE {}	Not present		
}			
}			
}			

– *RRCCONNECTIONREESTABLISHMENTREQUEST*

Table 4.6.1-13: RRCCONNECTIONREESTABLISHMENTREQUEST

Derivation Path: 36.331 clause 6.2.2			
Information Element	Value/remark	Comment	Condition
RRCCONNECTIONREESTABLISHMENTREQUEST ::= SEQUENCE {			
criticalExtensions CHOICE {			
rrcConnectionReestablishmentRequest-r8			
SEQUENCE {			
ue-Identity	Set according to specific message content		
reestablishmentCause	Set according to specific message content		
spare	Content not checked		
}			
}			
}			

– *RRCCONNECTIONREJECT*

Table 4.6.1-14: RRCCONNECTIONREJECT

Derivation Path: 36.331 clause 6.2.2			
Information Element	Value/remark	Comment	Condition
RRCCONNECTIONREJECT ::= SEQUENCE {			
criticalExtensions CHOICE {			
c1 CHOICE {			
rrcConnectionReject-r8 SEQUENCE {			
waitTime	3(seconds)		
nonCriticalExtension SEQUENCE {}	Not present		
}			
}			
}			
}			
}			

– *RRCCONNECTIONRELEASE***Table 4.6.1-15: RRCCONNECTIONRELEASE**

Derivation Path: 36.331 clause 6.2.2			
Information Element	Value/remark	Comment	Condition
RRCCONNECTIONRELEASE ::= SEQUENCE {			
rrc-TransactionIdentifier	RRC-TransactionIdentifier-DL		
criticalExtensions CHOICE {			
c1 CHOICE {			
rrcConnectionRelease-r8 SEQUENCE {			
releaseCause	other		
redirectedCarrierInfo	Not present		
idleModeMobilityControlInfo	Not present		
nonCriticalExtension SEQUENCE {}	Not present		
}			
}			
}			
}			

– *RRCCONNECTIONREQUEST***Table 4.6.1-16: RRCCONNECTIONREQUEST**

Derivation Path: 36.331 clause 6.2.2			
Information Element	Value/remark	Comment	Condition
RRCCONNECTIONREQUEST ::= SEQUENCE {			
criticalExtensions CHOICE {			
rrcConnectionRequest-r8 SEQUENCE {			
ue-Identity CHOICE {			
s-TMSI	Any allowed value		
}			
establishmentCause	Not checked		
spare	Content not checked		
}			
}			
}			

– *RRCCONNECTIONSETUP***Table 4.6.1-17: RRCCONNECTIONSETUP**

Derivation Path: 36.331 clause 6.2.2			
Information Element	Value/remark	Comment	Condition
RRCCONNECTIONSETUP ::= SEQUENCE {			
rrc-TransactionIdentifier	RRC-TransactionIdentifier-DL		
criticalExtensions CHOICE {			
c1 CHOICE {			
rrcConnectionSetup-r8 SEQUENCE {			
radioResourceConfigDedicated	RadioResourceConfigDedicated-SRB1		
nonCriticalExtension SEQUENCE {}	Not present		
}			
}			
}			
}			

– *RRCConnectionSetupComplete*

Table 4.6.1-18: RRCConnectionSetupComplete

Derivation Path: 36.331 clause 6.2.2			
Information Element	Value/remark	Comment	Condition
RRCConnectionSetupComplete ::= SEQUENCE {			
rrc-TransactionIdentifier	RRC-TransactionIdentifier-UL		
criticalExtensions CHOICE {			
c1 CHOICE {			
rrcConnectionSetupComplete-r8 SEQUENCE {			
selectedPLMN-Identity	Set to the PLMN selected by upper layers		
registeredMME	Not present		
dedicatedInfoNAS	Not checked		
nonCriticalExtension SEQUENCE {}	Not checked		
}			
}			
}			
}			

– *SecurityModeCommand*

Table 4.6.1-19: SecurityModeCommand

Derivation Path: 36.331 clause 6.2.2			
Information Element	Value/remark	Comment	Condition
SecurityModeCommand ::= SEQUENCE {			
rrc-TransactionIdentifier	RRC-TransactionIdentifier-DL		
criticalExtensions CHOICE {			
c1 CHOICE{			
securityModeCommand-r8 SEQUENCE {			
securityConfigSMC	SecurityConfigSMC-DEFAULT		
nonCriticalExtension SEQUENCE {}	Not present		
}			
}			
}			
}			

– *SecurityModeComplete*

Table 4.6.1-20: SecurityModeComplete

Derivation Path: 36.331 clause 6.2.2			
Information Element	Value/remark	Comment	Condition
SecurityModeComplete ::= SEQUENCE {			
rrc-TransactionIdentifier	RRC-TransactionIdentifier-UL		
criticalExtensions CHOICE {			
securityModeComplete-r8 SEQUENCE {			
nonCriticalExtension SEQUENCE {}	Not checked		
}			
}			
}			

– *SecurityModeFailure***Table 4.6.1-21: SecurityModeFailure**

Derivation Path: 36.331 clause 6.2.2			
Information Element	Value/remark	Comment	Condition
SecurityModeFailure ::= SEQUENCE {			
rrc-TransactionIdentifier	RRC-TransactionIdentifier-UL		
criticalExtensions CHOICE {			
securityModeFailure-r8 SEQUENCE {			
nonCriticalExtension SEQUENCE {}	Not checked		
}			
}			
}			

– *UECapabilityEnquiry***Table 4.6.1-22: UECapabilityEnquiry**

Derivation Path: 36.331 clause 6.2.2			
Information Element	Value/remark	Comment	Condition
UECapabilityEnquiry ::= SEQUENCE {			
rrc-TransactionIdentifier	RRC-TransactionIdentifier-DL		
criticalExtensions CHOICE {			
c1 CHOICE {			
ueCapabilityEnquiry-r8 SEQUENCE {			
ue-CapabilityRequest	eutra		
nonCriticalExtension SEQUENCE {}	Not present		
}			
}			
}			
}			

– *UECapabilityInformation***Table 4.6.1-23: UECapabilityInformation**

Derivation Path: 36.331 clause 6.2.2			
Information Element	Value/remark	Comment	Condition
UECapabilityInformation ::= SEQUENCE {			
rrc-TransactionIdentifier	RRC-TransactionIdentifier-UL		
criticalExtensions CHOICE {			
c1 CHOICE {			
ueCapabilityInformation-r8 SEQUENCE {			
ue-CapabilityRAT-ContainerList	Stated capability shall be compatible with 3GPP TS 36.523-2 (ICS statements) and the user settings		
nonCriticalExtension SEQUENCE {}	Not checked		
}			
}			
}			
}			

- *ULHandoverPreparationTransfer*

Table 4.6.1-24: *ULHandoverPreparationTransfer*

Derivation Path: 36.331 clause 6.2.2			
Information Element	Value/remark	Comment	Condition
ULHandoverPreparationTransfer ::= SEQUENCE {			
criticalExtensions CHOICE {			
c1 CHOICE {			
ulHandoverPreparationTransfer-r8 SEQUENCE			
{			
cdma2000-Type	type1XRTT		
meid	Set to the 56 bit CDMA2000 mobile identification number of the UE		
dedicatedInfo	Set according to specific message content		
nonCriticalExtension SEQUENCE {}	Not checked		
}			
}			
}			
}			

- *ULInformationTransfer*

Table 4.6.1-25: *ULInformationTransfer*

Derivation Path: 36.331 clause 6.2.2			
Information Element	Value/remark	Comment	Condition
ULInformationTransfer ::= SEQUENCE {			
criticalExtensions CHOICE {			
c1 CHOICE {			
ulInformationTransfer-r8 SEQUENCE {			
dedicatedInfoType CHOICE {			
dedicatedInfoNAS	Set according to specific message content		
}			
nonCriticalExtension SEQUENCE {}	Not checked		
}			
}			
}			

4.6.2 System information blocks

See subclause 4.4.3.3 in this document.

4.6.3 Radio resource control information elements

– BCCH-Config-DEFAULT

Table 4.6.3-1: BCCH-Config-DEFAULT

Derivation Path: 36.331 clause 6.3.2			
Information Element	Value/remark	Comment	Condition
BCCH-Config-DEFAULT ::= SEQUENCE {			
modificationPeriodCoeff	n4	To provide reliable delivery of SI change notifications.	
}			

– CQI-ReportConfig-DEFAULT

Table 4.6.3-2: CQI-ReportConfig-DEFAULT

Derivation Path: 36.331 clause 6.3.2			
Information Element	Value/remark	Comment	Condition
CQI-ReportConfig-DEFAULT ::= SEQUENCE {			
cqi-ReportModeAperiodic	rm30		
nomPDSCH-RS-EPRE-Offset	0		
cqi-ReportPeriodic	Not present		
cqi-ReportPeriodic CHOICE {			CQI_PERIODIC
setup SEQUENCE {			
cqi-PUCCH-ResourceIndex	0		
cqi-pmi-ConfigIndex	25	(see Table 7.2.2-1A in TS 36.213)	FDD
	24	(see Table 7.2.2-1C in TS 36.213)	TDD
cqi-FormatIndicatorPeriodic CHOICE {			
widebandCQI	NULL		
}			
ri-ConfigIndex	483	(see Table 7.2.2-1B in TS 36.213)	FDD
	484	(see Table 7.2.2-1B in TS 36.213) This value for TDD is selected together with cqi-pmi-ConfigIndex based on TDD configuration 1.	TDD
simultaneousAckNackAndCQI	FALSE		
}			
}			
}			

Condition	Explanation
CQI_PERIODIC	When periodic CQI reporting should be enabled
FDD	FDD cell environment
TDD	TDD cell environment

– DRB-ToAddModList-RECONFIG

Table 4.6.3-2A: DRB-ToAddModList-RECONFIG

Derivation Path: 36.331 clause 6.3.2			
Information Element	Value/remark	Comment	Condition
DRB-ToAddModList ::= SEQUENCE (SIZE (1..maxDRB)) OF SEQUENCE {	2 Entries		
eps-BearerIdentity[1]	5		
drb-Identity[1]	1		
pdcp-Config[1]	PDCP-Config-RECONFIG-AM		
rlc-Config[1]	RLC-Config-DRB-AM-RECONFIG		
logicalChannelIdentity[1]	Not present		
logicalChannelConfig[1]	Not present		
eps-BearerIdentity[2]	6		
drb-Identity[2]	2		
pdcp-Config[2]	PDCP-Config-RECONFIG-UM		
rlc-Config[2]	RLC-Config-DRB-UM-RECONFIG		
logicalChannelIdentity[2]	Not present		
logicalChannelConfig[2]	Not present		
}			

– PCCH-Config-DEFAULT

Table 4.6.3-3: PCCH-Config-DEFAULT

Derivation Path: 36.331 clause 6.3.2			
Information Element	Value/remark	Comment	Condition
PCCH-Config-DEFAULT ::= SEQUENCE {			
defaultPagingCycle	rf128	Typical value in real network.	
nB	oneT		
}			

– PDCP-Config-RECONFIG-AM

Table 4.6.3-3A: PDCP-Config-RECONFIG-AM

Derivation Path: 36.508 table 4.8.2.1.2.2-1: PDCP-Config-DRB-AM			
Information Element	Value/remark	Comment	Condition
PDCP-Config-DRB-AM ::= SEQUENCE {			
discardTimer	ms750		
headerCompression	notUsed		
}			

– PDCP-Config-RECONFIG-UM

Table 4.6.3-3B: PDCP-Config-RECONFIG-UM

Derivation Path: 36.508 table 4.8.2.1.2.1-1: PDCP-Config-DRB-UM			
Information Element	Value/remark	Comment	Condition
PDCP-Config-DRB-UM ::= SEQUENCE {			
discardTimer	ms150		
headerCompression	notUsed		
}			

– PHICH-Config-DEFAULT

Table 4.6.3-4: PHICH-Config-DEFAULT

Derivation Path: 36.331 clause 6.3.2			
Information Element	Value/remark	Comment	Condition
PHICH-Config-DEFAULT ::= SEQUENCE {			
phich-Duration	normal		
phich-Resource	one	Ng=1 has been selected to ensure enough PHICH resources from the real network point of view.	
}			

– PDSCH-ConfigCommon-DEFAULT

Table 4.6.3-5: PDSCH-ConfigCommon-DEFAULT

Derivation Path: 36.331 clause 6.3.2			
Information Element	Value/remark	Comment	Condition
PDSCH-ConfigCommon-DEFAULT ::= SEQUENCE {			
referenceSignalPower	18 (dBm)		
p-b	0 ($\rho_B / \rho_A = 1$)		1TX
	1 ($\rho_B / \rho_A = 1$)		2TX
}			

Condition	Explanation
1TX	1 SS Tx antenna environment
2TX	2 SS Tx antenna environment

– PDSCH-ConfigDedicated-DEFAULT

Table 4.6.3-6: PDSCH-ConfigDedicated-DEFAULT

Derivation Path: 36.331 clause 6.3.2			
Information Element	Value/remark	Comment	Condition
PDSCH-ConfigDedicated-DEFAULT ::= SEQUENCE {			
p-a	dB0		1TX
	dB-3		2TX
}			

– PRACH-Config-DEFAULT

Table 4.6.3-7: PRACH-Config-DEFAULT

Derivation Path: 36.331 clause 6.3.2			
Information Element	Value/remark	Comment	Condition
PRACH-Config-DEFAULT ::= SEQUENCE {			
rootSequenceIndex	22	Corresponding to $u = 1$ (See table 5.7.2-4 in TS 36.211 for PRACH format 0-3)	FDD
	0	Corresponding to $u = 1$ (See table 5.7.2-5 in TS 36.211 for PRACH format 4)	TDD
prach-ConfigInfo SEQUENCE {			
prach-ConfigIndex	3	Typical value in real network for FDD (see table 5.7.1-1 and 5.7.1-2 in TS 36.211)	FDD
	51	Typical value in real network for TDD (see table 5.7.1-3 and 5.7.1-4 in TS 36.211)	TDD
highSpeedFlag	FALSE (Unrestricted set)	High speed train configuration doesn't apply by default.	
zeroCorrelationZoneConfig	5 (N_{cs} configuration = 5)	Assuming cell radius is up to approximately 3 km.	FDD
	4 (N_{cs} configuration = 4)	Assuming cell radius is up to approximately 1 km.	TDD
prach-FreqOffset	See subclause 4.6.8	Channel-bandwidth-dependent parameter	
}			
}			
Note: Although PRACH format 0-3 is applicable for both FDD and TDD, the PRACH format 4 is used as default for testing for TDD.			

Condition	Explanation
FDD	FDD cell environment
TDD	TDD cell environment

– PRACH-ConfigSIB-DEFAULT

Table 4.6.3-7a: PRACH-ConfigSIB-DEFAULT

Derivation Path: 36.508 clause 4.6.3 Table 4.6.3-7 PRACH-Config-DEFAULT

– PUCCH-ConfigCommon-DEFAULT

Table 4.6.3-8: PUCCH-ConfigCommon-DEFAULT

Derivation Path: 36.331 clause 6.3.2			
Information Element	Value/remark	Comment	Condition
PUCCH-ConfigCommon-DEFAULT ::= SEQUENCE {			
deltaPUCCH-Shift	ds2	Assuming typical values of the maximum delay spread	
nRB-CQI	See subclause 4.6.8	Channel-bandwidth-dependent parameter	
nCS-AN	6		
n1PUCCH-AN	0		
}			

– PUCCH-ConfigDedicated-DEFAULT

Table 4.6.3-9: PUCCH-ConfigDedicated-DEFAULT

Derivation Path: 36.331 clause 6.3.2			
Information Element	Value/remark	Comment	Condition
PUCCH-ConfigDedicated-DEFAULT ::= SEQUENCE {			
ackNackRepetition CHOICE {			
release	NULL		
}			
tddAckNackFeedbackMode	Not present		FDD
	multiplexing	Multiplexing is selected as default to align with RAN4's assumptions in RF tests.	TDD
}			

Condition	Explanation
FDD	FDD cell environment
TDD	TDD cell environment

– PUSCH-ConfigCommon-DEFAULT

Table 4.6.3-10: PUSCH-ConfigCommon-DEFAULT

Derivation Path: 36.331 clause 6.3.2			
Information Element	Value/remark	Comment	Condition
PUSCH-ConfigCommon-DEFAULT ::= SEQUENCE {			
pusch-ConfigBasic SEQUENCE {			
n-SB	1	Typical configuration in real network	
hoppingMode	interSubFrame	Typical configuration in real network	
pusch-HoppingOffset	See subclause 4.6.8	Channel-bandwidth-dependent parameter	
enable64QAM	FALSE		
}			
ul-ReferenceSignalsPUSCH SEQUENCE {			
groupHoppingEnabled	TRUE	In accordance with “the RAN5 LTE UE Feature list”.	
groupAssignmentPUSCH	0	Typical value in real network	
sequenceHoppingEnabled	FALSE	In accordance with “the RAN5 LTE UE Feature list”.	
cyclicShift	0		
}			
}			

– PUSCH-ConfigDedicated-DEFAULT

Table 4.6.3-11: PUSCH-ConfigDedicated-DEFAULT

Derivation Path: 36.331 clause 6.3.2			
Information Element	Value/remark	Comment	Condition
PUSCH-ConfigDedicated-DEFAULT ::= SEQUENCE {			
betaOffset-ACK-Index	9		
betaOffset-RI-Index	6		
betaOffset-CQI-Index	6		
}			

– RACH-ConfigCommon-DEFAULT

Table 4.6.3-12: RACH-ConfigCommon-DEFAULT

Derivation Path: 36.331 clause 6.3.2			
Information Element	Value/remark	Comment	Condition
RACH-ConfigCommon-DEFAULT ::= SEQUENCE {			
preambleInfo SEQUENCE {			
numberOfRA-Preambles	n52	Assuming the number of dedicated preambles is 12.	
preamblesGroupAConfig SEQUENCE {}	Not present		
}			
powerRampingParameters SEQUENCE {			
powerRampingStep	dB2		
preambleInitialReceivedTargetPower	dBm-104 (default)	Thermal noise = -113 dBm NF = 5 dB IoT = 6 dB Required SNR = -8 dB (See table 8.4.2-1 in TS 36.104 [30]) -> -110 dB (default value is acceptable)	
}			
ra-SupervisionInfo SEQUENCE {			
preambleTransMax	n6	Under the condition of Case 1 in RAN1 simulation assumptions, an UE with pathloss of CDF = 90% reaches the maximum transmit power in 4 successive retransmissions. 6 has been selected considering the margin of 2.	
ra-ResponseWindowSize	sf10	The maximum value is preferable.	
mac-ContentionResolutionTimer	sf48	Allows for a sufficient number of msg3 retransmissions.	
}			
maxHARQ-Msg3Tx	4	Under the condition of Target SIR = 2 dB, the probability of 2 transmissions is less than 1%. 4 has been selected considering the margin of 2.	
}			

– RadioResourceConfigCommon-DEFAULT

Table 4.6.3-13: RadioResourceConfigCommon-DEFAULT

Derivation Path: 36.331 clause 6.3.2			
Information Element	Value/remark	Comment	Condition
RadioResourceConfigCommon-DEFAULT ::= SEQUENCE {			
rach-ConfigCommon	RACH-ConfigCommon-DEFAULT		
prach-Config	PRACH-Config-DEFAULT		
pdsch-ConfigCommon	Not present		
pusch-ConfigCommon	PUSCH-ConfigCommon-DEFAULT		
phich-Config	Not present		
pucch-ConfigCommon	Not present		
soundingRSUL-ConfigCommon	SoundingRS-UL-ConfigCommon-DEFAULT		
uplinkPowerControlCommon	Not present		
antennaInfoCommon	Not present		
p-Max	Not present		
tdd-Config	Not present		FDD
	TDD-Config-DEFAULT		TDD
ul-CyclicPrefixLength	len1		
}			

Condition	Explanation
FDD	FDD cell environment
TDD	TDD cell environment

– RadioResourceConfigCommonSIB-DEFAULT

Table 4.6.3-14: RadioResourceConfigCommonSIB-DEFAULT

Derivation Path: 36.331 clause 6.3.2			
Information Element	Value/remark	Comment	Condition
RadioResourceConfigCommonSIB-DEFAULT ::= SEQUENCE {			
rach-ConfigCommon	RACH-ConfigCommon-DEFAULT		
bcch-Config	BCCH-Config-DEFAULT		
pcch-Config	PCCH-Config-DEFAULT		
prach-Config	PRACH-ConfigSIB-DEFAULT		
pdsch-ConfigCommon	PDSCH-ConfigCommon-DEFAULT		
pusch-ConfigCommon	PUSCH-ConfigCommon-DEFAULT		
pucch-ConfigCommon	PUCCH-ConfigCommon-DEFAULT		
soundingRS-UL-ConfigCommon	SoundingRS-UL-ConfigCommon-DEFAULT		
uplinkPowerControlCommon	UplinkPowerControlCommon-DEFAULT		
ul-CyclicPrefixLength	len1		
}			

– RadioResourceConfigDedicated-SRB1

Table 4.6.3-15: RadioResourceConfigDedicated-SRB1

Derivation Path: 36.331 clause 6.3.2			
Information Element	Value/remark	Comment	Condition
RadioResourceConfigDedicated-SRB1 ::= SEQUENCE {			
srb-ToAddModList SEQUENCE (SIZE (1..2)) OF SEQUENCE {}	1 entry, with value SRB-ToAddMod-DEFAULT using condition SRB1		
drb-ToAddModList	Not present		
drb-ToReleaseList	Not present		
mac-MainConfig CHOICE {			
explicitValue	MAC-MainConfig-SRB	See subclause 4.8.2	
}			
sps-Config	Not present		
physicalConfigDedicated	PhysicalConfigDedicated-DEFAULT using condition SRB1	See subclause 4.8.2	
}			

– RadioResourceConfigDedicated-SRB2-DRB(n,m)

Table 4.6.3-16: RadioResourceConfigDedicated-SRB2-DRB(n,m)

Derivation Path: 36.331 clause 6.3.2			
Information Element	Value/remark	Comment	Condition
RadioResourceConfigDedicated-SRB2-DRB(n, m) ::= SEQUENCE {		n is the number of AM RLC DRBs (1..N) m is the number of UM RLC DRBs (0..M)	
srb-ToAddModList SEQUENCE (SIZE (1..2)) OF SEQUENCE {	1 entry		
srb-ToAddMod[1]	SRB-ToAddMod-DEFAULT using condition SRB2	See subclause 4.8.2	
}			
drb-ToAddModList SEQUENCE (SIZE (1..maxDRB)) OF SEQUENCE {	n+m entries		
drb-ToAddMod[k, k=1..n]	DRB-ToAddMod-DEFAULT (k) using condition AM	n AM RLC DRBs See subclause 4.8.2	
drb-ToAddMod[k, k=n+1..n+m]	DRB-ToAddMod-DEFAULT (k) using condition UM	m UM RLC DRBs See subclause 4.8.2	m>0
}			
drb-ToReleaseList	Not present		
mac-MainConfig CHOICE {			
explicitValue	MAC-MainConfig-RBC using condition DRX_L (note)	See subclause 4.8.2	m=0
	MAC-MainConfig-RBC using condition DRX_S (note)	See subclause 4.8.2	m>0
}			
sps-Config	Not present		
physicalConfigDedicated	PhysicalConfigDedicated - DEFAULT using condition RBC	See subclause 4.8.2	
}			
NOTE: In cases where no RLC-UM bearer is configured, large DRX Cycle length is used. In cases where at least one RLC-UM bearer is configured, small DRX Cycle length is used.			

Condition	Explanation
m=0	m is equal to zero
m>0	m is greater than zero

RadioResourceConfigDedicated-DRB(n,m)

Table 4.6.3-17: RadioResourceConfigDedicated-DRB(n,m)

Derivation Path: 36.331 clause 6.3.2			
Information Element	Value/remark	Comment	Condition
RadioResourceConfigDedicated-DRB(n, m) ::= SEQUENCE {		n is the number of AM RLC DRBs (0..N) m is the number of UM RLC DRBs (0..M)	
srb-ToAddModList	Not present		
drb-ToAddModList SEQUENCE (SIZE (1..maxDRB)) OF SEQUENCE {	n+m entries	BID is the total number of established DRBs in the UE, before applying the contents of this IE	
drb-ToAddMod[k, k=BID+1..BID+n]	DRB-ToAddMod-DEFAULT (k) using condition AM	n AM RLC DRBs See subclause 4.8.2	n>0
drb-ToAddMod[k, k= BID+1+n.. BID+n+m]	DRB-ToAddMod-DEFAULT (k) using condition UM	m UM RLC DRBs See subclause 4.8.2	m>0
}			
drb-ToReleaseList	Not present		
mac-MainConfig	Not present (note)		m=0
mac-MainConfig CHOICE {			m>0
explicitValue	MAC-MainConfig-RBC using condition DRX_S (note)	See subclause 4.8.2	
}			
sps-Config	Not present		
physicalConfigDedicated	Not present		
}			
NOTE: In cases where no RLC-UM bearer is added, existing DRX configuration is used without modification. In cases where at least one RLC-UM bearer is added, small DRX Cycle length is used.			

Condition	Explanation
n>0	n is greater than zero
m=0	m is equal to zero
m>0	m is greater than zero

RadioResourceConfigDedicated-SRB1-SRB2-DRB(n,m)

Table 4.6.3-18: RadioResourceConfigDedicated-SRB1-SRB2-DRB(n,m)

Derivation Path: 36.331 clause 6.3.2			
Information Element	Value/remark	Comment	Condition
RadioResourceConfigDedicated-SRB1-SRB2-DRB(n, m) ::= SEQUENCE {		n is the number of AM RLC DRBs (1..N) m is the number of UM RLC DRBs (0..M)	
srb-ToAddModList SEQUENCE (SIZE (1..2)) OF SEQUENCE {	2 entries		
srb-ToAddMod[1]	SRB-ToAddMod-DEFAULT using condition SRB1	See subclause 4.8.2	
srb-ToAddMod[2]	SRB-ToAddMod-DEFAULT using condition SRB2	See subclause 4.8.2	
}			
drb-ToAddModList SEQUENCE (SIZE (1..maxDRB)) OF SEQUENCE {	n+m entries		
drb-ToAddMod[k, k=1..n]	DRB-ToAddMod-DEFAULT (k) using condition AM	n AM RLC DRBs See subclause 4.8.2	
drb-ToAddMod[k, k=n+1..n+m]	DRB-ToAddMod-DEFAULT (k) using condition UM	m UM RLC DRBs See subclause 4.8.2	m>0
}			
drb-ToReleaseList	Not present		
mac-MainConfig CHOICE {			
explicitValue	MAC-MainConfig-RBC using condition DRX_L (note)	See subclause 4.8.2	m=0
	MAC-MainConfig-RBC using condition DRX_S (note)	See subclause 4.8.2	m>0
}			
sps-Config	Not present		
physicalConfigDedicated	PhysicalConfigDedicated - DEFAULT using condition RBC	See subclause 4.8.2	
}			
NOTE: In cases where no RLC-UM bearer is configured, large DRX Cycle length is used. In cases where at least one RLC-UM bearer is configured, small DRX Cycle length is used.			

Condition	Explanation
m=0	m is equal to zero
m>0	m is greater than zero

– RadioResourceConfigDedicated-HO

Table 4.6.3-19: RadioResourceConfigDedicated-HO

Derivation Path: 36.331 clause 6.3.2			
Information Element	Value/remark	Comment	Condition
RadioResourceConfigDedicated-HO ::= SEQUENCE {			
srb-ToAddModList	Not present		
drb-ToAddModList	Not present		
drb-ToReleaseList	Not present		
mac-MainConfig	Not present		
sps-Config	Not present		
physicalConfigDedicated	PhysicalConfigDedicated-DEFAULT using condition RBC	See subclause 4.8.2	
}			

– RLC-Config-DRB-AM-RECONFIG

Table 4.6.3-19A: RLC-Config-DRB-AM-RECONFIG

Derivation Path: 36.508 table 4.8.2.1.3.2-1: RLC-Config-DRB-AM			
Information Element	Value/remark	Comment	Condition
RLC-Config-DRB-AM-RECONFIG ::= CHOICE {			
am SEQUENCE {			
ul-AM-RLC SEQUENCE {			
t-PollRetransmit	ms855		
pollPDU	p64		
pollByte	kB250		
maxRetxThreshold	t8		
}			
dl-AM-RLC SEQUENCE {			
t-Reordering	ms85		
t-StatusProhibit	ms50		
}			
}			
}			

– RLC-Config-DRB-UM-RECONFIG

Table 4.6.3-19B: RLC-Config-DRB-UM-RECONFIG

Derivation Path: 36.508 table 4.8.2.1.3.1-1: RLC-Config-DRB-UM			
Information Element	Value/remark	Comment	Condition
RLC-Config-DRB-UM-RECONFIG ::= CHOICE {			
um-Bi-Directional SEQUENCE {			
ul-UM-RLC SEQUENCE {			
sn-FieldLength	Size10		
}			
dl-UM-RLC SEQUENCE {			
sn-FieldLength	Size10		
t-Reordering	ms55		
}			
}			
}			

– RLC-Config-SRB-AM-RECONFIG

Table 4.6.3-19C: RLC-Config-SRB-AM-RECONFIG

Derivation Path: 36.331 clause 6.3.2, 9.2.1			
Information Element	Value/remark	Comment	Condition
RLC-Config-SRB-AM-RECONFIG ::= CHOICE {			
am SEQUENCE {			
ul-AM-RLC SEQUENCE {			
t-PollRetransmit	ms50		
pollPDU	pInfinity	Default	
pollByte	kBinfinity	Default	
maxRetxThreshold	t6		
}			
dl-AM-RLC SEQUENCE {			
t-Reordering	ms40		
t-StatusProhibit	ms0	Default	
}			
}			
}			

– SchedulingRequest-Config-DEFAULT

Table 4.6.3-20: SchedulingRequest-Config-DEFAULT

Derivation Path: 36.331 clause 6.3.2			
Information Element	Value/remark	Comment	Condition
SchedulingRequest-Config-DEFAULT ::= CHOICE {			
setup SEQUENCE {			
sr-PUCCH-ResourceIndex	See subclause 4.6.8	Channel-bandwidth-dependent parameter	
sr-ConfigIndex	30		
dsr-TransMax	n4		
}			
}			

– SoundingRS-UL-ConfigCommon-DEFAULT

Table 4.6.3-21: SoundingRS-UL-ConfigCommon-DEFAULT

Derivation Path: 36.331 clause 6.3.2			
Information Element	Value/remark	Comment	Condition
SoundingRS-UL-ConfigCommon-DEFAULT ::= SEQUENCE {			
setup SEQUENCE {			
-srs-BandwidthConfig	See subclause 4.6.8	Channel-bandwidth-dependent parameter	
srs-SubframeConfig	sc0	Assuming SRS density is high (see Table 5.5.3.3-1 in TS 36.211)	FDD
	sc4	Assuming SRS density is high (see Table 5.5.3.3-2 in TS 36.211)	TDD
ackNackSRS-SimultaneousTransmission	TRUE	Typical value in real network	
srs-MaxUpPts	Not Present		
}			
}			

Condition	Explanation
FDD	FDD cell environment
TDD	TDD cell environment

– SoundingRS-UL-ConfigDedicated-DEFAULT

Table 4.6.3-22: SoundingRS-UL-ConfigDedicated-DEFAULT

Derivation Path: 36.331 clause 6.3.2			
Information Element	Value/remark	Comment	Condition
SoundingRS-UL-ConfigDedicated-DEFAULT ::= CHOICE {			
setup SEQUENCE {			
srs-Bandwidth	bw0	bw0 used with no frequency hopping. bw3 used with frequency hopping	
srs-HoppingBandwidth	hbw0		
freqDomainPosition	0		
duration	TRUE		
srs-ConfigIndex	20	See Table 8.2-1 in TS 36.213	FDD
	31	INTEGER (0..1023) See Table 8.2-2 in TS 36.213	TDD
transmissionComb	0		
cyclicShift	cs0		
}			
}			

Condition	Explanation
FDD	FDD cell environment
TDD	TDD cell environment

– SRB-ToAddModList-RECONFIG

Table 4.6.3-22A: SRB-ToAddModList-RECONFIG

Derivation Path: 36.331 clause 6.3.2			
Information Element	Value/remark	Comment	Condition
SRB-ToAddModList ::= SEQUENCE (SIZE (1..2)) OF SEQUENCE {	2 Entries		
srb-Identity[1]	1		
rlc-Config[1] CHOICE {			
explicitValue	RLC-Config-SRB-AM-RECONFIG		
logicalChannelConfig[1] CHOICE {			
defaultValue	NULL		
}			
srb-Identity[2]	2		
rlc-Config[2] CHOICE {			
explicitValue	RLC-Config-SRB-AM-RECONFIG		
}			
logicalChannelConfig[2] CHOICE {			
defaultValue	NULL		
}			
}			

– TDD-Config-DEFAULT

Table 4.6.3-23: TDD-Config-DEFAULT

Derivation Path: 36.331 clause 6.3.2			
Information Element	Value/remark	Comment	Condition
TDD-Config-DEFAULT ::= SEQUENCE {			
subframeAssignment	sa1		
specialSubframePatterns	Ssp6		
}			

– TPC-PDCCH-Config-DEFAULT

Table 4.6.3-24: TPC-PDCCH-Config-DEFAULT

Derivation Path: 36.331 clause 6.3.2			
Information Element	Value/remark	Comment	Condition
TPC-PDCCH-Config-DEFAULT ::= CHOICE {			
setup SEQUENCE {			
tpc-RNTI	'03FF'H '01FA'H		PUCCH PUSCH
tpc-Index CHOICE {			
indexOfFormat3	1		
}			
}			
}			

Condition	Explanation
-----------	-------------

PUCCH	For PUCCH
PUSCH	For PUSCH

– UplinkPowerControlCommon-DEFAULT

Table 4.6.3-25: UplinkPowerControlCommon-DEFAULT

Derivation Path: 36.331 clause 6.3.2			
Information Element	Value/remark	Comment	Condition
UplinkPowerControlCommon-DEFAULT ::= SEQUENCE {			
p0-NominalPUSCH	-85 (-85 dBm)	Typical value in real network	
alpha	alpha0 (0.8)	Typical value in real network	
p0-NominalPUCCH	-117 (-117 dBm)	Thermal noise = -121 dBm NF = 5 dB IoT = 6 dB Required SNR = -7.5 dB (1-bit A/N) -> -117 dB	
deltaFList-PUCCH SEQUENCE {			
deltaF-PUCCH-Format1	deltaF0	In accordance with RAN1 simulation results	
deltaF-PUCCH-Format1b	deltaF3	In accordance with RAN1 simulation results	
deltaF-PUCCH-Format2	deltaF0	In accordance with RAN1 simulation results	
deltaF-PUCCH-Format2a	deltaF0	In accordance with RAN1 simulation results	
deltaF-PUCCH-Format2b	deltaF0	In accordance with RAN1 simulation results	
}			
deltaPreambleMsg3	4		
}			

– UplinkPowerControlDedicated-DEFAULT

Table 4.6.3-26: UplinkPowerControlDedicated-DEFAULT

Derivation Path: 36.331 clause 6.3.2			
Information Element	Value/remark	Comment	Condition
UplinkPowerControlDedicated-DEFAULT ::= SEQUENCE {			
p0-UE-PUSCH	0		
deltaMCS-Enabled	en0		
accumulationEnabled	TRUE		
p0-UE-PUCCH	0		
pSRS-Offset	3 (-6 dB)		
filterCoefficient	fc4		
}			

4.6.4 Security control information elements

– SecurityConfigHO-DEFAULT

Table 4.6.4-1: SecurityConfigHO-DEFAULT

Derivation Path: 36.331 clause 6.2,2, 6.3.3			
Information Element	Value/remark	Comment	Condition
SecurityConfigHO-DEFAULT ::= SEQUENCE {			
handoverType CHOICE {			
intraLTE SEQUENCE {			
securityAlgorithmConfig	Not present		
keyChangeIndicator	FALSE		
nextHopChainingCount	0		
}			
}			
}			

– SecurityConfigSMC-DEFAULT

Table 4.6.4-2: SecurityConfigSMC-DEFAULT

Derivation Path: 36.331 clause 6.2,2, 6.3.3			
Information Element	Value/remark	Comment	Condition
SecurityConfigSMC-DEFAULT ::= SEQUENCE {			
securityAlgorithmConfig SEQUENCE {			
cipheringAlgorithm	Set according to PIXIT parameter for default ciphering algorithm [FFS]		
integrityProtAlgorithm	Set according to PIXIT parameter for default integrity protection algorithm [FFS]		
}			
}			

4.6.5 Mobility control information elements

– MobilityControlInfo-HO

Table 4.6.5-1: MobilityControlInfo-HO

Derivation Path: 36.331 clause 6.3.4			
Information Element	Value/remark	Comment	Condition
MobilityControlInfo-HO ::= SEQUENCE {			
targetPhysCellId	Set according to specific message content		
carrierFreq	Set according to specific message content		
carrierBandwidth	Not present		
additionalSpectrumEmission	Not present		
t304	ms1000		
newUE-Identity	SS arbitrarily selects a value between '003C'H and 'FFF2'H.		
radioResourceConfigCommon	RadioResourceConfigCommon-DEFAULT		
rach-ConfigDedicated	Not present		
}			

4.6.6 Measurement information elements

- MeasConfig-DEFAULT

Table 4.6.6-1: MeasConfig-DEFAULT

Derivation Path: 36.331, clause 6.3.5			
Information Element	Value/remark	Comment	Condition
MeasConfig-DEFAULT ::= SEQUENCE {			
measObjectToRemoveList	Not present		
measObjectToAddModList	Not present		
reportConfigToRemoveList	Not present		
reportConfigToAddModList	Not present		
measIdToRemoveList	Not present		
measIdToAddModList	Not present		
quantityConfig	Not present		
	QuantityConfig-DEFAULT		UTRAN, GERAN, CDMA2000
measGapConfig	Not present		
	MeasGapConfig-GP1		INTER-FREQ, UTRAN
	MeasGapConfig-GP2		GERAN, INTER-RAT
s-Measure	Not present		
preRegistrationInfoHRPD	Not present		
speedStatePars	Not present		
}			

Condition	Explanation
-----------	-------------

INTER-FREQ	For E-UTRA inter-freq measurements
UTRAN	For inter-RAT measurements with UTRAN
GERAN	For inter-RAT measurements with GERAN
INTER-RAT	For inter-RAT measurements with UTRAN and GERAN
CDMA2000	For inter-RAT measurements with CDMA2000

- MeasGapConfig-GP1

Table 4.6.6-1A: MeasGapConfig-GP1

Derivation Path: 36.331, clause 6.3.5			
Information Element	Value/remark	Comment	Condition
MeasGapConfig-GP1 ::= CHOICE {			
setup SEQUENCE {			
gapOffset CHOICE {			
gp0	0	TGRP = 40 ms	
}			
}			
}			

- MeasGapConfig-GP2

Table 4.6.6-1B: MeasGapConfig-GP2

Derivation Path: 36.331, clause 6.3.5			
Information Element	Value/remark	Comment	Condition
MeasGapConfig-GP2 ::= CHOICE {			
setup SEQUENCE {			
gapOffset CHOICE {			
gp1	0	TGRP = 80 ms	
}			
}			
}			

– MeasObjectCDMA2000-GENERIC

Table 4.6.6-1C: MeasObjectCDMA2000-GENERIC

Derivation Path: 36.331 clause 6.3.5			
Information Element	Value/remark	Comment	Condition
MeasObjectCDMA2000-GENERIC ::= SEQUENCE {			
cdma2000-Type	FFS	[type1XRTT, typeHRPD]	
carrierFreq SEQUENCE {			
bandClass	FFS	Should be one of the following: bc0, bc1, bc2, bc3, bc4, bc5, bc6, bc7, bc8, bc9, bc10, bc11, bc12, bc13, bc14, bc15, bc16, bc17, spare14, spare13, spare12, spare11, spare10, spare9, spare8, spare7, spare6, spare5, spare4, spare3, spare2, spare1, ...	
arfcn	Downlink channel numberFFS	INTEGER (0 to 2047)	
}			
searchWindowSize	FFS	INTEGER (0..15)	
offsetFreq	0 (0 dB)		
cellsToRemoveList	Not present		
cellsToAddModList	[Not present]		
cellForWhichToReportCGI	Not present		
}			

- MeasObjectEUTRA-GENERIC

Table 4.6.6-2: MeasObjectEUTRA-GENERIC(Freq)

Derivation Path: 36.331 clause 6.3.5			
Information Element	Value/remark	Comment	Condition
MeasObjectEUTRA-GENERIC(Freq) ::= SEQUENCE {			
carrierFreq	Downlink EARFCN for Freq		
allowedmeasBandwidth	The number of the resource blocks for Freq		
presenceAntennaPort1	FALSE		
neighbourCellConfig	'01'B (No MBSFN subframes are present in all neighbour cells)	MBSFN doesn't apply by default.	
offsetFreq	0 (dB 0)		
cellsToRemoveList	Not present		
cellsToAddModList	Not present		
blackCellsToRemoveList	Not present		
blackCellsToAddModList	Not present		
cellForWhichToReportCGI	Not present		
}			

- MeasObjectGERAN-GENERIC

Table 4.6.6-2A: MeasObjectGERAN-GENERIC(Freq)

Derivation Path: 36.331 clause 6.3.5			
Information Element	Value/remark	Comment	Condition
MeasObjectGERAN-GENERIC(Freq) ::= SEQUENCE {			
carrierFreqs SEQUENCE {			
startingARFCN	Downlink GERAN ARFCN of Freq		
bandIndicator	Set according to the band used for GERAN cells under test		
followingARFCNs CHOICE {			
explicitListOfARFCNs	Set the corresponding ARFCN of GERAN cells under test		
}			
}			
offsetFreq	Not present		
ncc-Permitted	Not present		
cellForWhichToReportCGI	Not present		
}			

- MeasObjectUTRA-GENERIC

Table 4.6.6-3: MeasObjectUTRA-GENERIC(Freq)

Derivation Path: 36.331 clause 6.3.5			
Information Element	Value/remark	Comment	Condition
MeasObjectUTRA-GENERIC(Freq) ::= SEQUENCE {			
carrierFreq	Downlink UARFCN of Freq		
offsetFreq	0 (dB 0)		
cellsToRemoveList	Not present		
cellsToAddModList	Not present	For UTRA, the neighbouring cell list needs to be provided in specific test cases.	
cellForWhichToReportCGI	Not present		
}			

QuantityConfig-DEFAULT

Table 4.6.6-3A: QuantityConfig-DEFAULT

Derivation Path: 36.331, clause 6.3.5			
Information Element	Value/remark	Comment	Condition
QuantityConfig-DEFAULT ::= SEQUENCE {			
quantityConfigEUTRA SEQUENCE {}	Not present		
quantityConfigUTRA SEQUENCE {}	Not present		
quantityConfigUTRA SEQUENCE {			UTRAN
measQuantityUTRA-FDD	cpich-EcN0		
measQuantityUTRA-TDD	pccpch-RSCP		
filterCoefficient	Not present	DEFAULT fc4	
}			
quantityConfigGERAN SEQUENCE {}	Not present		
quantityConfigGERAN SEQUENCE {			GERAN
measQuantityGERAN	rssi		
filterCoefficient	Not present	DEFAULT fc2	
}			
quantityConfigCDMA2000 SEQUENCE {}	Not present		
quantityConfigCDMA2000 SEQUENCE {			CDMA2000
measQuantityCDMA2000	[FFS]		
}			
}			

Condition	Explanation
UTRAN	For inter-RAT measurements with UTRAN
GERAN	For inter-RAT measurements with GERAN
CDMA2000	For inter-RAT measurements with CDMA2000

- ReportConfigEUTRA-A1

Table 4.6.6-4: ReportConfigEUTRA-A1(Thres)

Derivation Path: 36.331 clause 6.3.5			
Information Element	Value/remark	Comment	Condition
ReportConfigEUTRA-A1(Thres) ::= SEQUENCE {			
triggerType CHOICE {			
event SEQUENCE {			
eventId CHOICE {			
eventA1 SEQUENCE {			
a1-Threshold CHOICE {			
threshold-RSRP	Thres+141	Thres is actual threshold value in dBm	
}			
}			
}			
}			
hysteresis	0 (0 dB)		
timeToTrigger	ms256		
}			
triggerQuantity	rsrp		
reportQuantity	both		
maxReportCells	1		
reportInterval	ms1024		
reportAmount	r1		
}			

- ReportConfigEUTRA-A2

Table 4.6.6-5: ReportConfigEUTRA-A2(Thres)

Derivation Path: 36.331 clause 6.3.5			
Information Element	Value/remark	Comment	Condition
ReportConfigEUTRA-A2(Thres) ::= SEQUENCE {			
triggerType CHOICE {			
event SEQUENCE {			
eventId CHOICE {			
eventA2 SEQUENCE {			
a2-Threshold CHOICE {			
threshold-RSRP	Thres+141	Thres is actual threshold value in dBm	
}			
}			
}			
hysteresis	0 (0 dB)		
timeToTrigger	ms320		
}			
triggerQuantity	rsrp		
reportQuantity	both		
maxReportCells	1		
reportInterval	ms1024		
reportAmount	r1		
}			

- ReportConfigEUTRA-A3

Table 4.6.6-6: ReportConfigEUTRA-A3

Derivation Path: 36.331 clause 6.3.5			
Information Element	Value/remark	Comment	Condition
ReportConfigEUTRA-A3 ::= SEQUENCE {			
triggerType CHOICE {			
event SEQUENCE {			
eventId CHOICE {			
eventA3 SEQUENCE {			
a3-Offset	0 (0 dB)	To reduce interference between intra-frequency multiple cells	
reportOnLeave	FALSE		
}			
}			
hysteresis	0 (0 dB)		
timeToTrigger	ms640		
}			
triggerQuantity	rsrp		
reportQuantity	both		
maxReportCells	1		
reportInterval	ms1024		
reportAmount	r1		
}			

- ReportConfigEUTRA-PERIODICAL

Table 4.6.6-7: ReportConfigEUTRA-PERIODICAL

Derivation Path: 36.331 clause 6.3.5			
Information Element	Value/remark	Comment	Condition
ReportConfigEUTRA-PERIODICAL ::= SEQUENCE {			
triggerType CHOICE {			
periodical SEQUENCE {			
purpose CHOICE {			
reportStrongestCells	NULL		
}			
}			
}			
triggerQuantity	rsrp		
reportQuantity	both		
maxReportCells	1		
reportInterval	ms1024		
reportAmount	infinity		
}			

- ReportConfigInterRAT-B1-GERAN

Table 4.6.6-7A: ReportConfigInterRAT-B1-GERAN(GERAN-Thres)

Derivation Path: 36.331 clause 6.3.5			
Information Element	Value/remark	Comment	Condition
ReportConfigInterRAT-B1-GERAN(GERAN-Thres) ::= SEQUENCE {			
triggerType CHOICE {			
event SEQUENCE {			
eventId CHOICE {			
eventB1 SEQUENCE {			
b1-Threshold CHOICE {			
b1-ThresholdGERAN	(GERAN-Thres + 110)	GERAN-Thres is actual value in dBm	
}			
}			
}			
}			
hysteresis	FFS	INTEGER(0..30)	
timeToTrigger	ms0		
}			
maxReportCells	6	In line with RAN4 requirement	
reportInterval	ms1024		
reportAmount	r1		
}			

- ReportConfigInterRAT-B1-UTRA

Table 4.6.6-7B: ReportConfigInterRAT-B1-UTRA(UTRA-Thres)

Derivation Path: 36.331 clause 6.3.5			
Information Element	Value/remark	Comment	Condition
ReportConfigInterRAT-B1-UTRA(UTRA-Thres) ::= SEQUENCE {			
triggerType CHOICE {			
event SEQUENCE {			
eventId CHOICE {			
eventB1 SEQUENCE {			
b1-Threshold CHOICE {			
b1-ThresholdUTRA CHOICE {			
utra-EcN0	(UTRA-Thres * 2 + 49)	UTRA-Thres is actual Ec/NO value in dB	UTRA-FDD
utra-RSCP	UTRA-Thres + 115	UTRA-Thres is actual RSCP value in dBm	UTRA-TDD
}			
}			
}			
}			
}			
hysteresis	3 (1.5 dB)		
timeToTrigger	ms0		
}			
}			
maxReportCells	6	In line with RAN4 requirement	
reportInterval	ms1024		
reportAmount	r1		
}			

Condition	Explanation
UTRA-FDD	UTRA FDD cell environment
UTRA-TDD	UTRA TDD cell environment

- ReportConfigInterRAT-B2-CDMA2000

Table 4.6.6-7C: ReportConfigInterRAT-B2-CDMA2000(EUTRA-Thres, CDMA2000-Thres)

Derivation Path: 36.331 clause 6.3.5			
Information Element	Value/remark	Comment	Condition
ReportConfigInterRAT-B2-CDMA2000(EUTRA-Thres, CDMA2000-Thres) ::= SEQUENCE {			
triggerType CHOICE {			
event SEQUENCE {			
eventId CHOICE {			
eventB2 SEQUENCE {			
b2-Threshold1 CHOICE {			
threshold-RSRP	EUTRA-Thres+141	EUTRA-Thres is actual threshold value in dBm	
}			
b2-Threshold2 CHOICE {			
b2-Threshold2CDMA2000	[30 (-15 dB)]	Integer (0..63)	
}			
}			
}			
hysteresis	[2 (1 dB)]	INTEGER(0..30)	
timeToTrigger	ms0		
}			
maxReportCells	[8]		
reportInterval	[ms2048]	Range: ms120, ms240, ms480, ms640, ms1024, ms2048, ms5120, ms10240, min1, min6, min12, min30, min60, spare3, spare2, spare1	
reportAmount	[r1]	Range: r1, r2, r4, r8, r16, r32, r64, infinity	
}			

- Table 4.6.6-7D: void-ReportConfigInterRAT-B2-GERAN

Table 4.6.6-7E: ReportConfigInterRAT-B2-GERAN(EUTRA-Thres, GERAN-Thres)

Derivation Path: 36.331 clause 6.3.5			
Information Element	Value/remark	Comment	Condition
ReportConfigInterRAT-B2-GERAN(EUTRA-Thres, GERAN-Thres) ::= SEQUENCE {			
triggerType CHOICE {			
event SEQUENCE {			
eventId CHOICE {			
eventB2 SEQUENCE {			
b2-Threshold1 CHOICE {			
threshold-RSRP	EUTRA-Thres+141	EUTRA-Thres is actual threshold value in dBm	
}			
b2-Threshold2 CHOICE {			
b2-Threshold2GERAN	GERAN-Thres + 110	GERAN-Thres is actual value in dBm	
}			
}			
}			
hysteresis	FFS	INTEGER(0..30)	
timeToTrigger	ms0		
}			
maxReportCells	6	In line with RAN4 requirement	
reportInterval	ms1024		
reportAmount	r1		
}			

- ReportConfigInterRAT-B2-UTRA

Table 4.6.6-8: ReportConfigInterRAT-B2-UTRA(EUTRA-Thres, UTRA-Thres)

Derivation Path: 36.331 clause 6.3.5			
Information Element	Value/remark	Comment	Condition
ReportConfigInterRAT-B2-UTRA(EUTRA-Thres, UTRA-Thres) ::= SEQUENCE {			
triggerType CHOICE {			
event SEQUENCE {			
eventId CHOICE {			
eventB2 SEQUENCE {			
b2-Threshold1 CHOICE {			
threshold-RSRP	EUTRA-Thres+141	EUTRA-Thres is actual threshold value in dBm	
}			
b2-Threshold2 CHOICE {			
b2-Threshold2UTRA CHOICE {			
utra-EcN0	UTRA-Thres * 2 + 49	UTRA-Thres is actual Ec/NO value in dB	UTRA-FDD
utra-RSCP	UTRA-Thres + 115	UTRA-Thres is actual RSCP value in dBm	UTRA-TDD
}			
}			
}			
}			
hysteresis	3 (1.5 dB)		
timeToTrigger	ms0		
}			
}			
maxReportCells	6	In line with RAN4 requirement	
reportInterval	ms1024		
reportAmount	r1		
}			

Condition	Explanation
UTRA-FDD	UTRA FDD cell environment
UTRA-TDD	UTRA TDD cell environment

- ReportConfigInterRAT-PERIODICAL

Table 4.6.6-9: ReportConfigInterRAT-PERIODICAL

Derivation Path: 36.331 clause 6.3.5			
Information Element	Value/remark	Comment	Condition
ReportConfigInterRAT-PERIODICAL ::= SEQUENCE {			
triggerType CHOICE {			
periodical SEQUENCE {			
purpose CHOICE {			
reportStrongestCells	NULL		
}			
}			
}			
maxReportCells	1		
reportInterval	ms1024		
reportAmount	infinity		
}			

4.6.7 Other information elements

– RRC-TransactionIdentifier-DL

Table 4.6.7-1: RRC-TransactionIdentifier-DL

Derivation Path: 36.331 clause 6.3.6			
Information Element	Value/remark	Comment	Condition
RRC-TransactionIdentifier-DL ::=	0..3		

– RRC-TransactionIdentifier-UL

Table 4.6.7-2: RRC-TransactionIdentifier-UL

Derivation Path: 36.331 clause 6.3.6			
Information Element	Value/remark	Comment	Condition
RRC-TransactionIdentifier-UL ::=	0..3	The same value as the value of RRC-TransactionIdentifier-DL in the downlink message initiating the procedure	

4.6.8 Channel-bandwidth-dependent parameters

The default values of parameters which depend on the channel bandwidth are defined in table 4.6.8-1.

Table 4.6.8-1: Channel-bandwidth-dependent parameters

Information Element	Channel bandwidth						Comment
	1.4 MHz	3 MHz	5 MHz	10 MHz	15 MHz	20MHz	
Prach-FrequencyOffset	FFS	FFS	2	4	6	8	Typical value in real network
nRB-CQI	FFS	FFS	2	4	6	8	Selected based on typical maximum number of UEs.
Pusch-HoppingOffset	FFS	FFS	4	8	12	16	Typical value in real network
sr-PUCCH-ResourceIndex	FFS	FFS	20	41	62	84	
srs-BandwidthConfig	FFS	FFS	bw3 ($m_{SRS,b}$, N_b) = (20, 1), (4, 5), (4, 1), (4, 1)	bw2 ($m_{SRS,b}$, N_b) = (40, 1), (20, 2), (4, 5), (4, 1)	bw2 ($m_{SRS,b}$, N_b) = (60, 1), (20, 3), (4, 5), (4, 1)	bw2 ($m_{SRS,b}$, N_b) = (80, 1), (40, 2), (20, 2), (4, 5)	Selected in accordance with pucch-ResourceSize.

4.7 Default NAS message and information element contents

This clause contains the default values of common NAS messages and information elements, which apply to all test cases unless otherwise specified. All the messages and information elements are listed in alphabetical order.

4.7.1 Security protected NAS messages

In subclauses 4.7.2 and 4.7.3 in this document, all the NAS messages are described in the plain NAS message format.

When a NAS message is security protected, the message shall be contained by SECURITY PROTECTED NAS MESSAGE unless contained by another NAS message.

The default contents of SECURITY PROTECTED NAS MESSAGE message are defined in table 4.7.1-1.

Table 4.7.1-1: SECURITY PROTECTED NAS MESSAGE

Derivation Path: 24.301 clause 8.2.23			
Information Element	Value/remark	Comment	Condition
Protocol discriminator	EMM		
Security header type	'0001'B	Integrity protected	UNCIPHERED
	'0010'B	Integrity protected and ciphered	CIPHERED
	'0011'B	Integrity protected with new EPS security context	UNCIPHERED-NEW
	'0100'B	Integrity protected and ciphered with new EPS security context	CIPHERED-NEW
Message authentication code	The calculated value of MAC-I for this message.	The value of MAC-I is calculated by SS using Sequence number sent by UE.	SENT-BY-SS
	The same value as the XMAC-I value calculated by SS.		SENT-BY-UE
Sequence number	The internal counter of the SS		SENT-BY-SS
	Any allowed value		SENT-BY-UE
NAS message	Set according to specific message content		

Condition	Explanation
UNCIPHERED	This condition applies to unciphered NAS message exchange
CIPHERED	This condition applies to ciphered NAS message exchange
UNCIPHERED-NEW	This condition applies to unciphered NAS message exchange with new EPS security context
CIPHERED-NEW	This condition applies to ciphered NAS message exchange with new EPS security context
SENT-BY-SS	Use for the message sent from SS to UE
SENT-BY-UE	Use for the message sent from UE to SS

4.7.2 Contents of EMM messages

- ATTACH ACCEPT

This message is sent by the SS to the UE.

Table 4.7.2-1: ATTACH ACCEPT

Derivation Path: 24.301 clause 8.2.1			
Information Element	Value/remark	Comment	Condition
Protocol discriminator	EMM		
Security header type	'0000'B	Plain NAS message, not security protected	
Attach accept message identity	'0100 0010'B	Attach accept	
EPS attach result	'0001'B	EPS only	PSmodeConfigured OR EPSONlyAttachForced
	'0010'B	combined EPS/IMSI attach	CSPModeConfigured AND NOT EPSONlyAttachForced
Spare half octet	'0000'B		
T3412 value			
Timer value	'0 0000'B		
Unit	'111'B	value indicates that the timer is deactivated.	
TAI list			
Length of tracking area identity list contents	'0000 0110'B	6 octets	
Partial tracking area identity list 1			
Number of elements	'0 0000'B	1 element	
Type of list	'00'B	list of TACs belonging to one PLMN, with non-consecutive TAC values	
MCC	See table 4.4.2-2 in this document	For NAS test cases, see table 6.3.2.2-1.	
MNC	See table 4.4.2-2 in this document	For NAS test cases, see table 6.3.2.2-1.	
TAC 1	See table 4.4.2-2 in this document	For NAS test cases, see table 6.3.2.2-1.	
ESM message container	ACTIVATE DEFAULT EPS BEARER CONTEXT REQUEST message to activate the default bearer		
GUTI			
Length of EPS mobile identity contents	'0000 1010'B	10 octets	
Type of identity	'110'B	GUTI	
Odd/even indication	'0'B	even number of identity digits and also when the GUTI is used	
MCC	See table 4.4.2-2 in this document	For NAS test cases, see table 6.3.2.2-1.	
MNC	See table 4.4.2-2 in this document	For NAS test cases, see table 6.3.2.2-1.	

MME Group ID	See table 4.4.2-2 in this document	For NAS test cases, see table 6.3.2.2-1.	
MME Code	See table 4.4.2-2 in this document	For NAS test cases, see table 6.3.2.2-1.	
M-TMSI	See table 4.4.2-2 in this document	For NAS test cases, see table 6.3.2.2-1.	
Location area identification	Not present		PSmodeConfigured OR EPSONlyAttachForced
Location area identification			CSPSmodeConfigured AND NOT EPSONlyAttachForced
MCC	See subclause 4.4 in this document		
MNC	See subclause 4.4 in this document		
LAC	See subclause 4.4 in this document		
MS identity	Not present		PSmodeConfigured OR EPSONlyAttachForced
MS identity			CSPSmodeConfigured AND NOT EPSONlyAttachForced
Length of mobile identity contents	'0000 0101'B	5 octets	
Type of identity	'100'B	TMSI/P-TMSI/M-TMSI	
Odd/even indication	'0'B	even number of identity digits and also when the TMSI/P-TMSI or TMGI and optional MBMS Session Identity is used	
TMSI	See subclause 4.4 in this document		
EMM cause	Not present		PSmodeConfigured OR NOT EPSONlyAttachForced
	'0000 0010'B	EMM Cause #2 (IMSI unknown in HSS)	CSPSmodeConfigured AND EPSONlyAttachForced
T3402 value	Not present		
T3423 value	Not present		
Equivalent PLMNs	Not present		
Emergency Number List	Not present		

Condition	Explanation
-----------	-------------

PSmodeConfigured	This condition applies if the UE is configured to operate in PS mode of operation.
CSPSmodeConfigured	This condition applies if the UE is configured to operate in CS/PS mode 1 or CS/PS mode 2 of operation.
EPSOnlyAttachForced	This condition is used if the UE needs to attach to EPS services only regardless of the UE mode of operation. Every TC which uses this condition shall switch off the UE at the end of the test procedure.

NOTE: This message is always sent within SECURITY PROTECTED NAS MESSAGE message.

- ATTACH COMPLETE

This message is sent by the UE to the SS.

Table 4.7.2-2: ATTACH COMPLETE

Derivation Path: 24.301 clause 8.2.2			
Information Element	Value/remark	Comment	Condition
Protocol discriminator	EMM		
Security header type	'0000'B	Plain NAS message, not security protected	
Attach complete message identity	'0100 0011'B	Attach complete	
ESM message container	ACTIVATE DEFAULT EPS BEARER CONTEXT ACCEPT message		

NOTE: This message is always sent within SECURITY PROTECTED NAS MESSAGE message.

- ATTACH REJECT

This message is sent by the SS to the UE.

Table 4.7.2-3: ATTACH REJECT

Derivation Path: 24.301 clause 8.2.3			
Information Element	Value/remark	Comment	Condition
Protocol discriminator	EMM		
Security header type	'0000'B	Plain NAS message, not security protected	
Attach reject message identity	'0100 0100'B	Attach reject	
EMM cause	Set according to specific message content.		
ESM message container	Set according to specific message content.		

NOTE: This message is sent without integrity protection.

- ATTACH REQUEST

This message is sent by the UE to the SS.

Table 4.7.2-4: ATTACH REQUEST

Derivation Path: 24.301 clause 8.2.4			
Information Element	Value/remark	Comment	Condition
Protocol discriminator	EMM		
Security header type	'0000'B	Plain NAS message, not security protected	
Attach request message identity	'0100 0001'B	Attach request	
EPS attach type	'0001'B	EPS attach	PSmodeConfigured
	'0010'B	combined EPS/IMSI attach	CSPSmodeConfigured
NAS key set identifier	Any allowed value		
Old GUTI or IMSI	Any allowed value		
UE network capability	Any allowed value		
ESM message container	PDN CONNECTIVITY REQUEST message to request PDN connectivity to the default PDN		
Old P-TMSI signature	Not present or any allowed value		
Additional GUTI	Not present or any allowed value		
Last visited registered TAI	Not present or any allowed value		
DRX parameter	Not present or any allowed value		
MS network capability	Not present or any allowed value		
Old location area identification	Not present or any allowed value		
TMSI status	Not present or any allowed value		
Mobile station classmark 2	Not present or any allowed value		
Mobile station classmark 3	Not present or any allowed value		
Supported Codecs	Not present or any allowed value		

Condition	Explanation
PSmodeConfigured	See the definition below table 4.7.2-1.
CSPSmodeConfigured	See the definition below table 4.7.2-1.

NOTE: This message is sent without integrity protection before NAS security mode control procedure has been successfully completed and sent within SECURITY PROTECTED NAS MESSAGE message after NAS security mode control procedure has been successfully completed.

- AUTHENTICATION FAILURE

This message is sent by the UE to the SS.

Table 4.7.2-5: AUTHENTICATION FAILURE

Derivation Path: 24.301 clause 8.2.5			
Information Element	Value/remark	Comment	Condition
Protocol discriminator	EMM		
Security header type	'0000'B	Plain NAS message, not security protected	
Authentication failure message type	'0101 1100'B	Authentication failure	
EMM cause	'0001 0100'B	Mac failure	
Authentication failure parameter	Not present	See TS 24.301 [28] subclause 8.2.5.2	

NOTE: This message is sent without integrity protection before NAS security mode control procedure has been successfully completed and sent within SECURITY PROTECTED NAS MESSAGE message after NAS security mode control procedure has been successfully completed.

- AUTHENTICATION REJECT

This message is sent by the SS to the UE.

Table 4.7.2-6: AUTHENTICATION REJECT

Derivation Path: 24.301 clause 8.2.6			
Information Element	Value/remark	Comment	Condition
Protocol discriminator	EMM		
Security header type	'0000'B	Plain NAS message, not security protected	
Authentication reject message type	'0101 0100'B	Authentication reject	

NOTE: This message is sent without integrity protection.

- AUTHENTICATION REQUEST

This message is sent by the SS to the UE.

Table 4.7.2-7: AUTHENTICATION REQUEST

Derivation Path: 24.301 clause 8.2.7			
Information Element	Value/remark	Comment	Condition
Protocol discriminator	EMM		
Security header type	'0000'B	Plain NAS message, not security protected	
Authentication request message type	'0101 0010'B	Authentication request	
NAS key set identifier _{ASME}			
NAS key set identifier	An arbitrarily selected value between '000'B and '110'B, different from the valid NAS key set identifier of the UE if such a value exists.		
TSC	'0'B	native security context (for KSI _{ASME})	
Spare half octet	'0000'B		
Authentication parameter RAND (EPS challenge)	An arbitrarily selected 128 bits value		
Authentication parameter AUTN (EPS challenge)	See TS 24.301 [28] subclause 9.9.3.2		

NOTE: This message is sent without integrity protection.

- AUTHENTICATION RESPONSE

This message is sent by the UE to the SS.

Table 4.7.2-8: AUTHENTICATION RESPONSE

Derivation Path: 24.301 clause 8.2.8			
Information Element	Value/remark	Comment	Condition
Protocol discriminator	EMM		
Security header type	'0000'B	Plain NAS message, not security protected	
Authentication response message type	'0101 0011'B	Authentication response	
Authentication response parameter	See TS 24.301 [28] subclause 9.9.3.4		

NOTE: This message is sent without integrity protection before NAS security mode control procedure has been successfully completed and sent within SECURITY PROTECTED NAS MESSAGE message after NAS security mode control procedure has been successfully completed.

- CS SERVICE NOTIFICATION

This message is sent by the SS to the UE.

Table 4.7.2-8A: CS SERVICE NOTIFICATION

Derivation Path: 24.301 clause 8.2.9			
Information Element	Value/remark	Comment	Condition
Protocol discriminator	EMM		
Security header type	'0000'B	Plain NAS message, not security protected	
CS service notification message identity	'01100100'B	CS Service notification	
Paging identity	'1'B	TMSI	
CLI	Not present		
SS Code	Not present		
LCS indicator	Not present		
LCS client identity	Not present		

NOTE: This message is always sent within SECURITY PROTECTED NAS MESSAGE message.

- DETACH ACCEPT (UE originating detach)

This message is sent by the SS to the UE.

Table 4.7.2-9: DETACH ACCEPT

Derivation Path: 24.301 clause 8.2.10.1			
Information Element	Value/remark	Comment	Condition
Protocol discriminator	EMM		
Security header type	'0000'B	Plain NAS message, not security protected	
Detach accept message identity	'0100 0110'B	Detach accept	

NOTE: This message is sent without integrity protection.

- DETACH ACCEPT (UE terminated detach)

This message is sent by the UE to the SS.

Table 4.7.2-10: DETACH ACCEPT

Derivation Path: 24.301 clause 8.2.10.2			
Information Element	Value/remark	Comment	Condition
Protocol discriminator	EMM		
Security header type	'0000'B	Plain NAS message, not security protected	
Detach accept message identity	'0100 0110'B	Detach accept	

NOTE: This message is sent without integrity protection before NAS security mode control procedure has been successfully completed and sent within SECURITY PROTECTED NAS MESSAGE message after NAS security mode control procedure has been successfully completed.

- DETACH REQUEST (UE originating detach)

This message is sent by the UE to the SS.

Table 4.7.2-11: DETACH REQUEST

Derivation Path: 24.301 clause 8.2.11.1			
Information Element	Value/remark	Comment	Condition
Protocol discriminator	EMM		
Security header type	'0000'B	Plain NAS message, not security protected	
Detach request message identity	'0100 0101'B	Detach request	
Detach type			
Type of detach	'001'B	EPS detach	EPSONlyAttach
	'011'B	combined EPS/IMSI detach	CombinedAttach
Switch off	'1'B	switch off	
NAS key set identifier			
NAS key set identifier	The valid NAS key set identifier.		
TSC	'0'B	native security context (for KSI _{ASME})	
GUTI or IMSI	If the UE has a valid GUTI, set to the GUTI, otherwise set to the IMSI of the UE.		

Condition	Explanation
EPSONlyAttach	See the definition below table 4.7.2-24.
CombinedAttach	See the definition below table 4.7.2-24.

NOTE: This message is sent without integrity protection before NAS security mode control procedure has been successfully completed and sent within SECURITY PROTECTED NAS MESSAGE message after NAS security mode control procedure has been successfully completed.

- DETACH REQUEST (UE terminated detach)

This message is sent by the SS to the UE.

Table 4.7.2-12: DETACH REQUEST

Derivation Path: 24.301 clause 8.2.11.2			
Information Element	Value/remark	Comment	Condition
Protocol discriminator	EMM		
Security header type	'0000'B	Plain NAS message, not security protected	
Detach request message identity	'0100 0101'B	Detach request	
Detach type	Set according to specific message content.		
Spare half octet	'0000'B		
EMM cause	Set according to specific message content.		

NOTE: This message is always sent within SECURITY PROTECTED NAS MESSAGE message.

- **DOWNLINK NAS TRANSPORT**

This message is sent by the SS to the UE.

Table 4.7.2-12A: DOWNLINK NAS TRANSPORT

Derivation Path: 24.301 clause 8.2.12			
Information Element	Value/remark	Comment	Condition
Protocol discriminator	EMM		
Security header type	'0000'B	Plain NAS message, not security protected	
Downlink NAS transport message identity	'0110 0010'B	Downlink NAS transport	
NAS message container	Set according to specific message content		

NOTE: This message is always sent within SECURITY PROTECTED NAS MESSAGE message.

- **EMM INFORMATION**

This message is sent by the SS to the UE.

Table 4.7.2-13: EMM INFORMATION

Derivation Path: 24.301 clause 8.2.13			
Information Element	Value/remark	Comment	Condition
Protocol discriminator	EMM		
Security header type	'0000'B	Plain NAS message, not security protected	
EMM information message identity	'0110 0001'B	EMM information	
Full name for network	Set according to specific message content.		
Short name for network	Set according to specific message content.		
Local time zone	Set according to specific message content.		
Universal time and local time zone	Set according to specific message content.		
Network daylight saving time	Set according to specific message content.		

NOTE: This message is always sent within SECURITY PROTECTED NAS MESSAGE message.

- EMM STATUS

This message is sent by the UE or by the SS.

Table 4.7.2-14: EMM STATUS

Derivation Path: 24.301 clause 8.2.14			
Information Element	Value/remark	Comment	Condition
Protocol discriminator	EMM		
Security header type	'0000'B	Plain NAS message, not security protected	
EMM status message identity	'0110 0000'B	EMM status	
EMM cause	Set according to specific message content.		

NOTE: This message is always sent within SECURITY PROTECTED NAS MESSAGE message.

- EXTENDED SERVICE REQUEST

This message is sent by the UE to the SS.

Table 4.7.2-14A: EXTENDED SERVICE REQUEST

Derivation Path: 24.301 clause 8.2.15			
Information Element	Value/remark	Comment	Condition
Protocol discriminator	EMM		
Security header type	'0000'B	Plain NAS message, not security protected	
Extended service request message identity	'0100 1100'B	Extended service request	
Service type	'0001'B	mobile terminating CS fallback or 1xCS fallback	
NAS key set identifier			
NAS key set identifier	The valid NAS key set identifier.		
TSC	'0'B	native security context (for KSI _{ASME})	
M-TMSI	If the UE has a valid M-TMSI, set to the M-TMSI, otherwise set to the IMSI of the UE.		
CSFB response	Not present'001'B	CS fallback accepted by the UE	

NOTE: This message is always sent within SECURITY PROTECTED NAS MESSAGE message.

- GUTI REALLOCATION COMMAND

This message is sent by the SS to the UE.

Table 4.7.2-15: GUTI REALLOCATION COMMAND

Derivation Path: 24.301 clause 8.2.16			
Information Element	Value/remark	Comment	Condition
Protocol discriminator	EMM		
Security header type	'0000'B	Plain NAS message, not security protected	
GUTI reallocation command message identity	'0101 0000'B	GUTI reallocation command	
GUTI	Set according to specific message content.		
TAI list	Set according to specific message content.		

NOTE: This message is always sent within SECURITY PROTECTED NAS MESSAGE message.

- GUTI REALLOCATION COMPLETE

This message is sent by the UE to the SS.

Table 4.7.2-16: GUTI REALLOCATION COMPLETE

Derivation Path: 24.301 clause 8.2.17			
Information Element	Value/remark	Comment	Condition
Protocol discriminator	EMM		
Security header type	'0000'B	Plain NAS message, not security protected	
GUTI reallocation complete message identity	'0101 0001'B	GUTI reallocation complete	

NOTE: This message is always sent within SECURITY PROTECTED NAS MESSAGE message.

- IDENTITY REQUEST

This message is sent by the SS to the UE.

Table 4.7.2-17: IDENTITY REQUEST

Derivation Path: 24.301 clause 8.2.18			
Information Element	Value/remark	Comment	Condition
Protocol discriminator	EMM		
Security header type	'0000'B	Plain NAS message, not security protected	
Identity request message identity	'0101 0101'B	Identity request	
Identity type	'0001'B	IMSI	
Spare half octet	'0000'B		

NOTE: This message is sent without integrity protection.

- IDENTITY RESPONSE

This message is sent by the UE to the SS.

Table 4.7.2-18: IDENTITY RESPONSE

Derivation Path: 24.301 clause 8.2.19			
Information Element	Value/remark	Comment	Condition
Protocol discriminator	EMM		
Security header type	'0000'B	Plain NAS message, not security protected	
Identity response message	'0101 0110'B	Identity response	
Mobile identity	IMSI of the UE		

NOTE: This message is sent without integrity protection before NAS security mode control procedure has been successfully completed and sent within SECURITY PROTECTED NAS MESSAGE message after NAS security mode control procedure has been successfully completed. If identity type in IDENTITY REQUEST message indicates IMSI, this message is sent without integrity protection even if after NAS security mode control procedure has been successfully completed.

- SECURITY MODE COMMAND

This message is sent by the SS to the UE.

Table 4.7.2-19: SECURITY MODE COMMAND

Derivation Path: 24.301 clause 8.2.20			
Information Element	Value/remark	Comment	Condition
Protocol discriminator	EMM		
Security header type	'0000'B	Plain NAS message, not security protected	
Security mode command message identity	'0101 1101'B	Security mode command	
Selected NAS security algorithms			
Type of integrity protection algorithm	Set according to PIXIT parameter for default integrity protection algorithm [FFS]		
Type of ciphering algorithm	Set according to PIXIT parameter for default ciphering algorithm [FFS]		
NAS key set identifier			
NAS key set identifier	The valid NAS key set identifier.		
TSC	'0'B	native security context (for KSI _{ASME})	
Spare half octet	'0000'B		
Replayed UE security capabilities	Set according to the received UE security capabilities		
IMEISV request	Not present		
Replayed nonce _{UE}	Not present		
Nonce _{MME}	Not present		

NOTE: This message is always sent within SECURITY PROTECTED NAS MESSAGE message.

- SECURITY MODE COMPLETE

This message is sent by the UE to the SS.

Table 4.7.2-20: SECURITY MODE COMPLETE

Derivation Path: 24.301 clause 8.2.21			
Information Element	Value/remark	Comment	Condition
Protocol discriminator	EMM		
Security header type	'0000'B	Plain NAS message, not security protected	
Security mode complete message identity	'0101 1110'B	Security mode complete	
IMEISV	Not present		

NOTE: This message is always sent within SECURITY PROTECTED NAS MESSAGE message.

- SECURITY MODE REJECT

This message is sent by the UE to the SS.

Table 4.7.2-21: SECURITY MODE REJECT

Derivation Path: 24.301 clause 8.2.22			
Information Element	Value/remark	Comment	Condition
Protocol discriminator	EMM		
Security header type	'0000'B	Plain NAS message, not security protected	
Security mode reject message identity	'0101 1111'B	Security mode reject	
EMM cause	The value is set according to specific message content.		

NOTE: This message is sent without integrity protection before NAS security mode control procedure has been successfully completed and sent within SECURITY PROTECTED NAS MESSAGE message after NAS security mode control procedure has been successfully completed.

- SERVICE REJECT

This message is sent by the SS to the UE.

Table 4.7.2-22: SERVICE REJECT

Derivation Path: 24.301 clause 8.2.24			
Information Element	Value/remark	Comment	Condition
Protocol discriminator	EMM		
Security header type	'0000'B	Plain NAS message, not security protected	
Service reject message identity	'0100 1110'B	Service reject	
EMM cause	Set according to specific message content.		
T3442 value	Not present		

NOTE: This message is sent without integrity protection.

- SERVICE REQUEST

This message is sent by the UE to the SS.

Table 4.7.2-23: SERVICE REQUEST

Derivation Path: 24.301 clause 8.2.25			
Information Element	Value/remark	Comment	Condition
Protocol discriminator	EMM		
Security header type	'1100'B	Security header for the SERVICE REQUEST message	
KSI and sequence number			
Sequence number (short)	The 5 least significant bits of the NAS COUNT value applicable when this message is sent for sequence number.		
KSI	The effective KSI value.		
Message authentication code (short)	The 2 least significant octets of the resulting message authentication code		

- TRACKING AREA UPDATE ACCEPT

This message is sent by the SS to the UE.

Table 4.7.2-24: TRACKING AREA UPDATE ACCEPT

Derivation Path: 24.301 clause 8.2.26			
Information Element	Value/remark	Comment	Condition
Protocol discriminator	EMM		
Security header type	'0000'B	Plain NAS message, not security protected	
Tracking area update accept message identity	'0100 1001'B	Tracking area update accept	
EPS update result	'0000'B	TA updated	EPSONlyAttach
	'0001'B	combined TA/LA updated	CombinedAttach
Spare half octet	'0000'B		
T3412 value	Not present		
GUTI			
Length of EPS mobile identity contents	'0000 1010'B	10 octets	
Type of identity	'110'B	GUTI	
Odd/even indication	'0'B	even number of identity digits and also when the GUTI is used	
MCC	See table 4.4.2-2 in this document	For NAS test cases, see table 6.3.2.2-1.	
MNC	See table 4.4.2-2 in this document	For NAS test cases, see table 6.3.2.2-1.	
MME Group ID	See table 4.4.2-2 in this document	For NAS test cases, see table 6.3.2.2-1.	
MME Code	See table 4.4.2-2 in this document	For NAS test cases, see table 6.3.2.2-1.	
M-TMSI	See table 4.4.2-2 in this document	For NAS test cases, see table 6.3.2.2-1.	
TAI list			
Length of tracking area identity list contents	'0000 0110'B	6 octets	
Partial tracking area identity list 1			
Number of elements	'0 0000'B	1 element	
Type of list	'00'B	list of TACs belonging to one PLMN, with non-consecutive TAC values	
MCC	See table 4.4.2-2 in this document	For NAS test cases, see table 6.3.2.2-1.	
MNC	See table 4.4.2-2 in this document	For NAS test cases, see table 6.3.2.2-1.	
TAC 1	See table 4.4.2-2 in this document	For NAS test cases, see table 6.3.2.2-1.	
EPS bearer context status	The same value as the value set in TRACKING AREA UPDATE REQUEST message		
Location area identification	Not present		EPSONlyAttach
Location area identification			CombinedAttach

			tach
MCC	See subclause 4.4 in this document		
MNC	See subclause 4.4 in this document		
LAC	See subclause 4.4 in this document		
MS identity	Not present		EPSONlyAttach
MS identity			CombinedAttach
Length of mobile identity contents	'0000 0101'B	5 octets	
Type of identity	'100'B	TMSI/P-TMSI/M-TMSI	
Odd/even indication	'0'B	even number of identity digits and also when the TMSI/P-TMSI or TMGI and optional MBMS Session Identity is used	
TMSI	See subclause 4.4 in this document		
EMM cause	Not present		
T3402 value	Not present		
T3423 value	Not present		
Equivalent PLMNs	Not present		
Emergency Number List	Not present		

Condition	Explanation
EPSONlyAttach	This condition applies if the UE attached to EPS services only. SS applies this condition automatically according to the IE "EPS attach result" in ATTACH ACCEPT message.
CombinedAttach	This condition applies if the UE attached to both EPS and non-EPS services. SS applies this condition automatically according to the IE "EPS attach result" in ATTACH ACCEPT message.

NOTE: This message is always sent within SECURITY PROTECTED NAS MESSAGE message.

- TRACKING AREA UPDATE COMPLETE

This message is sent by the UE to the SS.

Table 4.7.2-25: TRACKING AREA UPDATE COMPLETE

Derivation Path: 24.301 clause 8.2.27			
Information Element	Value/remark	Comment	Condition
Protocol discriminator	EMM		
Security header type	'0000'B	Plain NAS message, not security protected	
Tracking area update complete message identity	'0100 1010'B	Tracking area update complete	

NOTE: This message is always sent within SECURITY PROTECTED NAS MESSAGE message.

- TRACKING AREA UPDATE REJECT

This message is sent by the SS to the UE.

Table 4.7.2-26: TRACKING AREA UPDATE REJECT

Derivation Path: 24.301 clause 8.2.28			
Information Element	Value/remark	Comment	Condition
Protocol discriminator	EMM		
Security header type	'0000'B	Plain NAS message, not security protected	
Tracking area update reject message identity	'0100 1011'B	Tracking area update reject	
EMM cause	Set according to specific message content.		

NOTE: This message is sent without integrity protection.

- TRACKING AREA UPDATE REQUEST

This message is sent by the UE to the SS.

Table 4.7.2-27: TRACKING AREA UPDATE REQUEST

Derivation Path: 24.301 clause 8.2.29			
Information Element	Value/remark	Comment	Condition
Protocol discriminator	EMM		
Security header type	'0000'B	Plain NAS message, not security protected	
Tracking area update request message identity	'0100 1000'B	Tracking area update request	
EPS update type			
EPS update type Value	'000'B	TA updating	EPSONlyAttach
	'001'B	Combined TA/LA updating	CombinedAttach
"Active" flag	'0'B	No bearer establishment requested	
NAS key set identifier			
NAS key set identifier	The valid NAS key set identifier of the UE		
TSC	'0'B	native security context (for KSI _{ASME})	
Old GUTI	Any allowed value		
Non-current native NAS key set identifier	Not present		
GPRS ciphering key sequence number	Not present		
Old P-TMSI signature	Not present		
Additional GUTI	Not present		
Nonce _{UE}	Not present		
UE network capability	Not present or any allowed value		
Last visited registered TAI	Not present or any allowed value		
DRX parameter	Not present		
UE radio capability information update needed	Not present		
EPS bearer context status	Any allowed value		
MS network capability	Not present or any allowed value		
Old location area identification	Not present or any allowed value		
TMSI status	Not present or any allowed value		
Mobile station classmark 2	Not present or any allowed value		
Mobile station classmark 3	Not present or any allowed value		
Supported Codecs	Not present or any allowed value		

Condition	Explanation
EPSONlyAttach	See the definition below table 4.7.2-24.
CombinedAttach	See the definition below table 4.7.2-24.

NOTE: This message is always sent within SECURITY PROTECTED NAS MESSAGE message.

- UPLINK NAS TRANSPORT

This message is sent by the UE to the SS.

Table 4.7.2-27A: UPLINK NAS TRANSPORT

Derivation Path: 24.301 clause 8.2.30			
Information Element	Value/remark	Comment	Condition
Protocol discriminator	EMM		
Security header type	'0000'B	Plain NAS message, not security protected	
Uplink NAS transport message identity	'0100 0011'B	Uplink NAS transport	
NAS message container	Set according to specific message content		

NOTE: This message is always sent within SECURITY PROTECTED NAS MESSAGE message.

4.7.3 Contents of ESM messages

- ACTIVATE DEDICATED EPS BEARER CONTEXT ACCEPT

This message is sent by the UE to the SS.

Table 4.7.3-1: ACTIVATE DEDICATED EPS BEARER CONTEXT ACCEPT

Derivation Path: 24.301 clause 8.3.1			
Information Element	Value/remark	Comment	Condition
Protocol discriminator	ESM		
EPS bearer identity	The same value as the value set in ACTIVATE DEDICATED EPS BEARER CONTEXT REQUEST message		
Procedure transaction identity	'0000 0000'B	No procedure transaction identity assigned	
Activate dedicated EPS bearer context accept message identity	'1100 0110'B	Activate dedicated EPS bearer context accept	
Protocol configuration options	Not present or any allowed value		

NOTE: This message is always sent within SECURITY PROTECTED NAS MESSAGE message.

- ACTIVATE DEDICATED EPS BEARER CONTEXT REJECT

This message is sent by UE to the SS.

Table 4.7.3-2: ACTIVATE DEDICATED EPS BEARER CONTEXT REJECT

Derivation Path: 24.301 clause 8.3.2			
Information Element	Value/remark	Comment	Condition
Protocol discriminator	ESM		
EPS bearer identity	The same value as the value set in ACTIVATE DEDICATED EPS BEARER CONTEXT REQUEST message.		
Procedure transaction identity	'0000 0000'B	No procedure transaction identity assigned	
Activate dedicated EPS bearer context reject message identity	'1100 0111'B	Activate dedicated EPS bearer context reject	
ESM cause	The value is set according to specific message content.		
Protocol configuration options	Not present		

NOTE: This message is always sent within SECURITY PROTECTED NAS MESSAGE message.

- ACTIVATE DEDICATED EPS BEARER CONTEXT REQUEST

This message is sent by the SS to the UE.

Table 4.7.3-3: ACTIVATE DEDICATED EPS BEARER CONTEXT REQUEST

Derivation Path: 24.301 clause 8.3.3			
Information Element	Value/remark	Comment	Condition
Protocol discriminator	ESM		
EPS bearer identity	Arbitrarily selected value between '0101'B and '1111'B.		
Procedure transaction identity	'0000 0000'B	No procedure transaction identity assigned	NETWORK-INITIATED
	The same value as the value set in BEARER RESOURCE MODIFICATION REQUEST message or BEARER RESOURCE ALLOCATION REQUEST message		UE-INITIATED
Activate dedicated EPS bearer context request message identity	'1100 0101'B	Activate dedicated EPS bearer context request	
Linked EPS bearer identity	The EPS bearer identity of the associated default bearer		
Spare half octet	'0000'B		
EPS QoS	See Reference dedicated EPS bearer context #1 in table 6.6.2-1		
TFT	See Reference dedicated EPS bearer context #1 in table 6.6.2-1		
Transaction identifier	Not present		
Negotiated QoS	See Reference dedicated EPS bearer context #1 in table 6.6.2-1		
Negotiated LLC SAPI	See Reference dedicated EPS bearer context #1 in table 6.6.2-1		
Radio priority	See Reference dedicated EPS bearer context #1 in table 6.6.2-1		
Packet flow Identifier	Not present		
Protocol configuration options	See Reference dedicated EPS bearer context #1 in table 6.6.2-1		

Condition	Explanation
NETWORK-INITIATED	Network initiated ESM procedures
UE-INITIATED	UE initiated ESM procedures

NOTE: This message is always sent within SECURITY PROTECTED NAS MESSAGE message.

- **ACTIVATE DEFAULT EPS BEARER CONTEXT ACCEPT**

This message is sent by the UE to the SS.

Table 4.7.3-4: ACTIVATE DEFAULT EPS BEARER CONTEXT ACCEPT

Derivation Path: 24.301 clause 8.3.4			
Information Element	Value/remark	Comment	Condition
Protocol discriminator	ESM		
EPS bearer identity	The same value as the value set in ACTIVATE DEFAULT EPS BEARER CONTEXT REQUEST message		
Procedure transaction identity	'0000 0000'B	No procedure transaction identity assigned	
Activate default EPS bearer context accept message identity	'1100 0010'B	Activate default EPS bearer context accept	
Protocol configuration options	Not present or any allowed value		

NOTE: This message is always sent within SECURITY PROTECTED NAS MESSAGE message.

- **ACTIVATE DEFAULT EPS BEARER CONTEXT REJECT**

This message is sent by UE to the SS.

Table 4.7.3-5: ACTIVATE DEFAULT EPS BEARER CONTEXT REJECT

Derivation Path: 24.301 clause 8.3.5			
Information Element	Value/remark	Comment	Condition
Protocol discriminator	ESM		
EPS bearer identity	The same value as the value set in ACTIVATE DEFAULT EPS BEARER CONTEXT REQUEST message.		
Procedure transaction identity	'0000 0000'B	No procedure transaction identity assigned	
Activate default EPS bearer context reject message identity	'1100 0011'B	Activate default EPS bearer context reject	
ESM cause	The value is set according to specific message content.		
Protocol configuration options	Not present		

NOTE: This message is always sent within SECURITY PROTECTED NAS MESSAGE message.

- ACTIVATE DEFAULT EPS BEARER CONTEXT REQUEST

This message is sent by the SS to the UE.

Table 4.7.3-6: ACTIVATE DEFAULT EPS BEARER CONTEXT REQUEST

Derivation Path: 24.301 clause 8.3.6			
Information Element	Value/remark	Comment	Condition
Protocol discriminator	ESM		
EPS bearer identity	An arbitrarily selected value between '0101'B and '1111'B.		
Procedure transaction identity	The same value as the value set in PDN CONNECTIVITY REQUEST message		
Activate default EPS bearer context request message identity	'1100 0001'B	Activate default EPS bearer context request	
EPS QoS	See Reference default EPS bearer context #1 in table 6.6.1-1		
Access point name	Any allowed value	SS defines a Default APN or, if The UE transmits an ESM INFORMATION RESPONSE message providing an APN, the SS shall use this value	
PDN address	See Reference default EPS bearer context #1 in table 6.6.1-1		pc_IPv4 AND NOT pc_IPv6
Length of PDN address contents	7 octets		
PDN type value	'001'B	IPv4	
PDN address information	IPv4 address	If in the last PDN CONNECTIVITY REQUEST the IE Protocol configuration options=000AH (IP address allocation via NAS signalling)	
	0.0.0.0	All other cases	
PDN address	See Reference default EPS bearer context #1 in table 6.6.1-1		pc_IPv6 AND NOT pc_IPv4
Length of PDN address contents	7 octets		
PDN type value	'010'B	IPv6	
PDN address information	IPv6 interface identifier		
PDN address	See Reference default EPS bearer context #1 in table 6.6.1-1		pc_IPv4 AND pc_IPv6
Length of PDN address contents	15 octets		
PDN type value	'011'B	IPv4v6	
PDN address information (Octets 4 to 11)	IPv6 interface identifier		
PDN address information (Octets 12 to 15)	IPv4 address	If in the last PDN CONNECTIVITY REQUEST the IE Protocol configuration options=000AH (IP address allocation via NAS	

		signalling)	
	0.0.0.0	All other cases	
Transaction identifier	Not present or any allowed value		
Negotiated QoS	See Reference default EPS bearer context #1 in table 6.6.1-1		
Negotiated LLC SAPI	See Reference default EPS bearer context #1 in table 6.6.1-1		
Radio priority	See Reference default EPS bearer context #1 in table 6.6.1-1		
Packet flow Identifier	Not present		
APN-AMBR	See Reference default EPS bearer context #1 in table 6.6.1-1		
ESM cause	Not present		
Protocol configuration options	See Reference default EPS bearer context #1 in table 6.6.1-1		

NOTE: This message is always sent within SECURITY PROTECTED NAS MESSAGE message.

- BEARER RESOURCE ALLOCATION REJECT

This message is sent by the SS to the UE.

Table 4.7.3-6A: BEARER RESOURCE ALLOCATION REJECT

Derivation Path: 24.301 clause 8.3.7			
Information Element	Value/remark	Comment	Condition
Protocol discriminator	ESM		
EPS bearer identity	'0000'B	No EPS bearer identity assigned	
Procedure transaction identity	The value indicated in BEARER RESOURCE ALLOCATION REQUEST message.		
Bearer resource allocation reject message identity	'1101 0101'B	Bearer resource allocation reject	
ESM cause	Set according to specific message content.		
Protocol configuration options	Not present		

NOTE: This message is always sent within SECURITY PROTECTED NAS MESSAGE message.

- BEARER RESOURCE ALLOCATION REQUEST

This message is sent by the UE to the SS.

Table 4.7.3-6B: BEARER RESOURCE ALLOCATION REQUEST

Derivation Path: 24.301 clause 8.3.8			
Information Element	Value/remark	Comment	Condition
Protocol discriminator	ESM		
EPS bearer identity	'0000'B	No EPS bearer identity assigned	
Procedure transaction identity	Any allowed value		
Bearer resource allocation request message identity	'1101 0100'B	Bearer resource allocation request	
Linked EPS bearer identity	The EPS bearer identity of the associated default bearer.		
Spare half octet	'0000'B		
Traffic flow aggregate			
Number of packet filters	Greater than 0 and less than or equal to 16		
E bit	Any allowed value		
TFT operation code	'001'B	Create new TFT	
Packet filter list	Any allowed value		
Parameters list	Not present or any allowed value		
Required traffic flow QoS	Any allowed value		
Protocol configuration options	Not present or any allowed value		

NOTE: This message is always sent within SECURITY PROTECTED NAS MESSAGE message.

- BEARER RESOURCE MODIFICATION REJECT

This message is sent by the SS to the UE.

Table 4.7.3-7: BEARER RESOURCE MODIFICATION REJECT

Derivation Path: 24.301 clause 8.3.9			
Information Element	Value/remark	Comment	Condition
Protocol discriminator	ESM		
EPS bearer identity	'0000'B	No EPS bearer identity assigned	
Procedure transaction identity	The value indicated in BEARER RESOURCE MODIFICATION REQUEST message.		
Bearer resource modification reject message identity	'1101 0111'B	Bearer resource modification reject	
ESM cause	Set according to specific message content.		
Protocol configuration options	Not present		

NOTE: This message is always sent within SECURITY PROTECTED NAS MESSAGE message.

- BEARER RESOURCE MODIFICATION REQUEST

This message is sent by the UE to the SS.

Table 4.7.3-8: BEARER RESOURCE MODIFICATION REQUEST

Derivation Path: 24.301 clause 8.3.10			
Information Element	Value/remark	Comment	Condition
Protocol discriminator	ESM		
EPS bearer identity	'0000'B	No EPS bearer identity assigned	
Procedure transaction identity	Any allowed value		
Bearer resource modification request message identity	'1101 0110'B	Bearer resource modification request	
EPS bearer identity for packet filter	The EPS bearer identity of the associated dedicated EPS bearer related with packet filter.		
Spare half octet	'0000'B		
Traffic flow aggregate	Any allowed value		
Traffic flow aggregate			RELEASE-REQUESTED
Number of packet filters	Greater than 0 and less than or equal to 16		
E bit	Any allowed value		
TFT operation code	'101'B	Delete packet filters from existing TFT	
Packet filter list	Any allowed value		
Parameters list	Not present or any allowed value		
Required traffic flow QoS	Not present or any allowed value		
ESM cause	Not present		
	'0010 0100'B	Regular deactivation	RELEASE-REQUESTED
Protocol configuration options	Not present or any allowed value		

Condition	Explanation
RELEASE-REQUESTED	UE requests the release of bearer resources.

NOTE: This message is always sent within SECURITY PROTECTED NAS MESSAGE message.

Table 4.7.3-9: (Void)

Table 4.7.3-10: (Void)

- DEACTIVATE EPS BEARER CONTEXT ACCEPT

This message is sent by the UE to the SS.

Table 4.7.3-11: DEACTIVATE EPS BEARER CONTEXT ACCEPT

Derivation Path: 24.301 clause 8.3.9			
Information Element	Value/remark	Comment	Condition
Protocol discriminator	ESM		
EPS bearer identity	The same value as the value set in DEACTIVATE EPS BEARER CONTEXT REQUEST message.		
Procedure transaction identity	'0000 0000'B	No procedure transaction identity assigned	
Deactivate EPS bearer context accept message identity	'1100 1110'B	Deactivate EPS bearer context accept	
Protocol configuration options	Not present		

NOTE: This message is always sent within SECURITY PROTECTED NAS MESSAGE message.

- DEACTIVATE EPS BEARER CONTEXT REQUEST

This message is sent by the SS to the UE.

Table 4.7.3-12: DEACTIVATE EPS BEARER CONTEXT REQUEST

Derivation Path: 24.301 clause 8.3.10			
Information Element	Value/remark	Comment	Condition
Protocol discriminator	ESM		
EPS bearer identity	Set according to specific message content.		
Procedure transaction identity	'0000 0000'B	No procedure transaction identity assigned	NETWORK-INITIATED
	The same value as the value set in PDN DISCONNECT REQUEST message or BEARER RESOURCE MODIFICATION REQUEST message.		UE-INITIATED
Deactivate EPS bearer context request message identity	'1100 1101'B	Deactivate EPS bearer context request	
ESM cause	Set according to specific message content.		
Protocol configuration options	Not present		

Condition	Explanation
NETWORK-INITIATED	Network initiated ESM procedures
UE-INITIATED	UE initiated ESM procedures

NOTE: This message is always sent within SECURITY PROTECTED NAS MESSAGE message.

- ESM INFORMATION REQUEST

This message is sent by the SS to the UE.

Table 4.7.3-13: ESM INFORMATION REQUEST

Derivation Path: 24.301 clause 8.3.11			
Information Element	Value/remark	Comment	Condition
Protocol discriminator	ESM		
EPS bearer identity	'0000'B	No EPS bearer identity assigned	
Procedure transaction identity	The value indicated in PDN CONNECTIVITY REQUEST message.		
ESM information request message identity	'1101 1001'B	ESM information request	

NOTE: This message is always sent within SECURITY PROTECTED NAS MESSAGE message.

- ESM INFORMATION RESPONSE

This message is sent by the UE to the SS.

Table 4.7.3-14: ESM INFORMATION RESPONSE

Derivation Path: 24.301 clause 8.3.12			
Information Element	Value/remark	Comment	Condition
Protocol discriminator	ESM		
EPS bearer identity	'0000'B	No EPS bearer identity assigned	
Procedure transaction identity	The same value as the value set in ESM INFORMATION REQUEST message.		
ESM information response message identity	'1101 1010'B	ESM information response	
Access point name	Not present or any allowed value		
Protocol configuration options	Not present or any allowed value		

NOTE: This message is always sent within SECURITY PROTECTED NAS MESSAGE message.

- **ESM STATUS**

This message is sent by the UE or by the SS.

Table 4.7.3-15: ESM STATUS

Derivation Path: 24.301 clause 8.3.13			
Information Element	Value/remark	Comment	Condition
Protocol discriminator	ESM		
EPS bearer identity	Set according to specific message content.		
Procedure transaction identity	'0000 0000'B	No procedure transaction identity assigned	
ESM status message identity	'1110 1000'B	ESM status	
ESM cause	Set according to specific message content.		

NOTE: This message is always sent within SECURITY PROTECTED NAS MESSAGE message.

- **MODIFY EPS BEARER CONTEXT ACCEPT**

This message is sent by the UE to the SS.

Table 4.7.3-16: MODIFY EPS BEARER CONTEXT ACCEPT

Derivation Path: 24.301 clause 8.3.14			
Information Element	Value/remark	Comment	Condition
Protocol discriminator	ESM		
EPS bearer identity	The same value as the value set in MODIFY EPS BEARER CONTEXT REQUEST message.		
Procedure transaction identity	'0000 0000'B	No procedure transaction identity assigned	
Modify EPS bearer context accept message identity	'1100 1010'B	Modify EPS bearer context accept	
Protocol configuration options	Not present		

NOTE: This message is always sent within SECURITY PROTECTED NAS MESSAGE message.

- MODIFY EPS BEARER CONTEXT REJECT

This message is sent by the UE to the SS.

Table 4.7.3-17: MODIFY EPS BEARER CONTEXT REJECT

Derivation Path: 24.301 clause 8.3.15			
Information Element	Value/remark	Comment	Condition
Protocol discriminator	ESM		
EPS bearer identity	The same value as the value set in MODIFY EPS BEARER CONTEXT REQUEST message.		
Procedure transaction identity	'0000 0000'B	No procedure transaction identity assigned	
Modify EPS bearer context reject message identity	'1100 1011'B	Modify EPS bearer context reject	
ESM cause	The value is set according to specific message content.		
Protocol configuration options	Not present		

NOTE: This message is always sent within SECURITY PROTECTED NAS MESSAGE message.

- MODIFY EPS BEARER CONTEXT REQUEST

This message is sent by the SS to the UE.

Table 4.7.3-18: MODIFY EPS BEARER CONTEXT REQUEST

Derivation Path: 24.301 clause 8.3.16			
Information Element	Value/remark	Comment	Condition
Protocol discriminator	ESM		
EPS bearer identity	Set according to specific message content.		
Procedure transaction identity	'0000 0000'B	No procedure transaction identity assigned	NETWORK-INITIATED
	The same value as the value set in BEARER RESOURCE MODIFICATION REQUEST message or BEARER RESOURCE ALLOCATION REQUEST message.		UE-INITIATED
Modify EPS bearer context request message identity	'1100 1001'B	Modify EPS bearer context request	
New EPS QoS	For a default EPS bearer, see subclause 6.6.1. For a dedicated EPS bearer, see subclause 6.6.2.		
TFT	For a default EPS bearer, see subclause 6.6.1. For a dedicated EPS bearer, see subclause 6.6.2.		
New QoS	For a default EPS bearer, see subclause 6.6.1. For a dedicated EPS bearer, see subclause 6.6.2.		
Negotiated LLC SAPI	For a default EPS bearer, see subclause 6.6.1. For a dedicated EPS bearer, see subclause 6.6.2.		
Radio priority	For a default EPS bearer, see subclause 6.6.1. For a dedicated EPS bearer, see subclause 6.6.2.		
Packet flow Identifier	For a default EPS bearer, see subclause 6.6.1. For a dedicated EPS bearer, see subclause 6.6.2.		
APN-AMBR	For a default EPS bearer, see subclause 6.6.1. For a dedicated EPS bearer, see subclause 6.6.2.		
Protocol configuration options	Not present		

Condition	Explanation
NETWORK-INITIATED	Network initiated ESM procedures
UE-INITIATED	UE initiated ESM procedures

NOTE: This message is always sent within SECURITY PROTECTED NAS MESSAGE message.

- PDN CONNECTIVITY REJECT

This message is sent by the SS to the UE.

Table 4.7.3-19: PDN CONNECTIVITY REJECT

Derivation Path: 24.301 clause 8.3.17			
Information Element	Value/remark	Comment	Condition
Protocol discriminator	ESM		
EPS bearer identity	'0000'B	No EPS bearer identity assigned	
Procedure transaction identity	The same value as the value set in PDN CONNECTIVITY REQUEST message.		
PDN connectivity reject message identity	'1101 0001'B	PDN connectivity reject	
ESM cause	The value is set according to specific message content.		
Protocol configuration options	Not present		

NOTE: This message is sent without integrity protection.

- PDN CONNECTIVITY REQUEST

This message is sent by the UE to the SS.

Table 4.7.3-20: PDN CONNECTIVITY REQUEST

Derivation Path: 24.301 clause 8.3.18			
Information Element	Value/remark	Comment	Condition
Protocol discriminator	ESM		
EPS bearer identity	'0000'B	No EPS bearer identity assigned	
Procedure transaction identity	Any allowed value		
PDN connectivity request message identity	'1101 0000'B	PDN connectivity request	
Request type	'0001'B	initial request	
PDN type	'001'B	IPv4	pc_IPv4
	'010'B	IPv6	pc_IPv6
	'011'B	IPv4v6	pc_IPv4 AND pc_IPv6
	'100'B	unused; shall be interpreted as "IPv6" if received by the network	pc_IPv6
ESM information transfer flag	Not present or any allowed value		
Access point name	Not present or any allowed value		
Protocol configuration options	Not present or any allowed value different than '000A' OR '000B'		pc_IPv4 OR pc_IPv6
	'000A'H	IP address allocation via NAS signalling	pc_IPv4
	'000B'H	IPv4 address allocation via DHCPv4	pc_IPv4

NOTE: This message is sent without integrity protection before NAS security mode control procedure has been successfully completed and sent within SECURITY PROTECTED NAS MESSAGE message after NAS security mode control procedure has been successfully completed.

- PDN DISCONNECT REJECT

This message is sent by the SS to the UE.

Table 4.7.3-21: PDN DISCONNECT REJECT

Derivation Path: 24.301 clause 8.3.19			
Information Element	Value/remark	Comment	Condition
Protocol discriminator	ESM		
EPS bearer identity	'0000'B	No EPS bearer identity assigned	
Procedure transaction identity	The value indicated in PDN DISCONNECT REQUEST message.		
PDN disconnect reject message identity	'1101 0011'B	PDN disconnect reject	
ESM cause	Set according to specific message content.		
Protocol configuration options	Not present		

NOTE: This message is always sent within SECURITY PROTECTED NAS MESSAGE message.

- PDN DISCONNECT REQUEST

This message is sent by the UE to the SS.

Table 4.7.3-22: PDN DISCONNECT REQUEST

Derivation Path: 24.301 clause 8.3.20			
Information Element	Value/remark	Comment	Condition
Protocol discriminator	ESM		
EPS bearer identity	'0000'B	No EPS bearer identity assigned	
Procedure transaction identity	Any allowed value		
PDN disconnect request message identity	'1101 0010'B	PDN disconnect request	
Linked EPS bearer identity	The EPS bearer identity of the associated default bearer.		
Spare half octet	'0000'B		
Protocol configuration options	Not present		

NOTE: This message is always sent within SECURITY PROTECTED NAS MESSAGE message.

4.7A Default TC message and information element contents

This clause contains the default values of common TC (Test Control, see [38]) messages and information elements, which apply to all test cases unless otherwise specified. All the messages and information elements are listed in alphabetical order.

- ACTIVATE TEST MODE

This message is sent by the SS to the UE embedded in a RRC *DLInformationTransfer* message.

Table 4.7A-1: ACTIVATE TEST MODE

Derivation Path: 36.509 clause 6.5			
Information Element	Value/remark	Comment	Condition
Protocol discriminator	1 1 1 1		
Skip indicator	0 0 0 0		
Message type	1 0 0 0 0 1 0 0		
UE test loop mode	0 0 0 0 0 0 0 0	UE test loop mode A	UE TEST LOOP MODE A (default)
UE test loop mode	0 0 0 0 0 0 0 1	UE test loop mode B	UE TEST LOOP MODE B

Condition	Explanation
UE TEST LOOP MODE A	UE test loop function configured for UE test loop mode A operation.
UE TEST LOOP MODE B	UE test loop function configured for UE test loop mode B operation.

- ACTIVATE TEST MODE COMPLETE

This message is sent by the UE to the SS embedded in a RRC *ULInformationTransfer* message.

Table 4.7A-2: ACTIVATE TEST MODE COMPLETE

Derivation Path: 36.509 clause 6.6			
Information Element	Value/remark	Comment	Condition
Protocol discriminator	1 1 1 1		
Skip indicator	0 0 0 0		
Message type	1 0 0 0 0 1 0 1		

- CLOSE UE TEST LOOP

This message is sent by the SS to the UE embedded in a RRC *DLInformationTransfer* message.

Table 4.7A-3: CLOSE UE TEST LOOP

Derivation Path: 36.509 clause 6.1			
Information Element	Value/remark	Comment	Condition
Protocol discriminator	1 1 1 1		
Skip indicator	0 0 0 0		
Message type	1 0 0 0 0 0 0 0		
UE test loop mode	0 0 0 0 0 0 0 0	UE test loop mode A	UE TEST LOOP MODE A (default)
UE test loop mode A LB setup			
Length of UE test loop mode A LB setup list in bytes	0	No LB setup list. No scaling (UL RLC SDU size will be equal to the received DL SDU size)	
UE test loop mode B LB setup	Not present		UE TEST LOOP MODE B
UE test loop mode	0 0 0 0 0 0 0 1	UE test loop mode B	
UE test loop mode A LB setup	Not present		
UE test loop mode B LB setup			
IP PDU delay	0 0 0 0 0 0 0 0	No delay	

Condition	Explanation
UE TEST LOOP MODE A	UE test loop function configured for UE test loop mode A operation.
UE TEST LOOP MODE B	UE test loop function configured for UE test loop mode B operation.

- CLOSE UE TEST LOOP COMPLETE

This message is sent by the UE to the SS embedded in a RRC *ULInformationTransfer* message.

Table 4.7A-4: CLOSE UE TEST LOOP

Derivation Path: 36.509 clause 6.2			
Information Element	Value/remark	Comment	Condition
Protocol discriminator	1 1 1 1		
Skip indicator	0 0 0 0		
Message type	1 0 0 0 0 0 0 1		

- DEACTIVATE TEST MODE

This message is sent by the SS to the UE embedded in a RRC *DLInformationTransfer* message.

Table 4.7A-5: DEACTIVATE TEST MODE

Derivation Path: 36.509 clause 6.7			
Information Element	Value/remark	Comment	Condition
Protocol discriminator	1 1 1 1		
Skip indicator	0 0 0 0		
Message type	1 0 0 0 0 1 1 0		

- DEACTIVATE TEST MODE COMPLETE

This message is sent by the UE to the SS embedded in a RRC *ULInformationTransfer* message.

Table 4.7A-6: DEACTIVATE TEST MODE COMPLETE

Derivation Path: 36.509 clause 6.8			
Information Element	Value/remark	Comment	Condition
Protocol discriminator	1 1 1 1		
Skip indicator	0 0 0 0		
Message type	1 0 0 0 0 1 1 1		

- OPEN UE TEST LOOP

This message is sent by the SS to the UE embedded in a RRC *DLInformationTransfer* message.

Table 4.7A-7: OPEN UE TEST LOOP

Derivation Path: 36.509 clause 6.3			
Information Element	Value/remark	Comment	Condition
Protocol discriminator	1 1 1 1		
Skip indicator	0 0 0 0		
Message type	1 0 0 0 0 0 1 0		

- OPEN UE TEST LOOP COMPLETE

This message is sent by the UE to the SS embedded in a RRC *ULInformationTransfer* message.

Table 4.7A-8: OPEN UE TEST LOOP COMPLETE

Derivation Path: 36.509 clause 6.4			
Information Element	Value/remark	Comment	Condition
Protocol discriminator	1 1 1 1		
Skip indicator	0 0 0 0		
Message type	1 0 0 0 0 0 1 1		

4.8 Reference radio bearer configurations

4.8.1 General

4.8.2 SRB and DRB parameters and combinations

4.8.2.1 SRB and DRB parameters

4.8.2.1.1 SRB configurations

Table 4.8.2.1.1-1: SRB-ToAddMod-DEFAULT

Derivation Path: 36.331 clause 6.3.2			
Information Element	Value/remark	Comment	Condition
SRB-ToAddMod-DEFAULT ::= SEQUENCE {			
srb-Identity	1		SRB1
	2		SRB2
rlc-Config CHOICE {			
defaultValue			
}			
logicalChannelConfig CHOICE {			
defaultValue			
}			
}			

4.8.2.1.2 DRB PDCP configurations

4.8.2.1.2.1 DRB PDCP configurations for UM RLC

Table 4.8.2.1.2.1-1: PDCP-Config-DRB-UM

Derivation Path: 36.331 clause 6.3.2			
Information Element	Value/remark	Comment	Condition
PDCP-Config-DRB-UM ::= SEQUENCE {			
discardTimer	ms100	Suitable for real time services	
rlc-AM SEQUENCE {}	Not present		
rlc-UM SEQUENCE {			
pdcpc-SN-Size	Len12bits		
}			
headerCompression CHOICE {			
notUsed	NULL		
}			
}			

4.8.2.1.2.2 DRB PDCP configurations for AM RLC

Table 4.8.2.1.2.2-1: PDCP-Config-DRB-AM

Derivation Path: 36.331 clause 6.3.2			
Information Element	Value/remark	Comment	Condition
PDCP-Config-DRB-AM ::= SEQUENCE {			
discardTimer	Infinity		
rlc-AM SEQUENCE {			
statusReportRequired	TRUE		
}			
rlc-UM SEQUENCE { }	Not present		
headerCompression CHOICE {			
notUsed	NULL		
}			
}			

4.8.2.1.3 DRB RLC configurations

4.8.2.1.3.1 DRB UM RLC configurations

Table 4.8.2.1.3.1-1: RLC-Config-DRB-UM

Derivation Path: 36.331 clause 6.3.2			
Information Element	Value/remark	Comment	Condition
RLC-Config-DRB-UM ::= CHOICE {			
um-Bi-Directional SEQUENCE {			
ul-UM-RLC SEQUENCE {			
sn-FieldLength	Size10		
}			
dl-UM-RLC SEQUENCE {			
sn-FieldLength	Size10		
t-Reordering	ms50	ms50 provides sufficient margin	
}			
}			
}			

4.8.2.1.3.2 DRB AM RLC configurations

Table 4.8.2.1.3.2-1: RLC-Config-DRB-AM

Derivation Path: 36.331 clause 6.3.2			
Information Element	Value/remark	Comment	Condition
RLC-Config-DRB-AM ::= CHOICE {			
am SEQUENCE {			
ul-AM-RLC SEQUENCE {			
t-PollRetransmit	ms80		
pollPDU	p128		
pollByte	kB125		
maxRetxThreshold	t4		
}			
dl-AM-RLC SEQUENCE {			
t-Reordering	ms80	Is sufficient for 5 HARQ transmissions	
t-StatusProhibit	Ms60	Should be equal to or smaller than t-PollRetransmit.	
}			
}			
}			

4.8.2.1.4 DRB Logical Channel configurations

Table 4.8.2.1.4-1: LogicalChannelConfig-DRB

Derivation Path: 36.331 clause 6.3.2			
Information Element	Value/remark	Comment	Condition
LogicalChannelConfig-DRB ::= SEQUENCE {			
ul-SpecificParameters SEQUENCE {			
priority	6		HI
	13		LO
prioritisedBitRate	infinity	PBR is disabled.	
bucketSizeDuration	ms100		
logicalChannelGroup	1		HI
	2		LO
}			
}			

Condition	Explanation
HI	Used for DRBs with high logical channel priority
LO	Used for DRBs with low logical channel priority

4.8.2.1.5 MAC configurations

Table 4.8.2.1.5-1: MAC-MainConfig-RBC

Derivation Path: 36.331 clause 6.3.2			
Information Element	Value/remark	Comment	Condition
MAC-MainConfig-RBC ::= SEQUENCE {			
ul-SCH-Config SEQUENCE {			
maxHARQ-Tx	n5		
periodicBSR-Timer	sf20		
retxBSR-Timer	sf320		
ttiBundling	FALSE		
}			
drx-Config	Not present		NOT pc_FeatrGrp _5
drx-Config CHOICE {			pc_FeatrGrp _5 AND DRX_S
setup SEQUENCE {			
onDurationTimer	psf2		
drx-InactivityTimer	psf100		
drx-RetransmissionTimer	sf16		
longDRX-CycleStartOffset CHOICE {		sf40 typical value in real network for real-time services.	
sf40	0		
}			
shortDRX	Not present		
}			
drx-Config CHOICE {			pc_FeatrGrp _5 AND DRX_L
setup SEQUENCE {			
onDurationTimer	psf6		
drx-InactivityTimer	psf1920		
drx-RetransmissionTimer	sf16		
longDRX-CycleStartOffset CHOICE {		sf1280 typical value in real network for best- effort services.	
sf1280	0		
}			
shortDRX	Not present		
}			
timeAlignmentTimerDedicated	sf750		
phr-Config CHOICE {			
setup SEQUENCE {			
periodicPHR-Timer	sf500		
prohibitPHR-Timer	sf200		
dl-PathlossChange	dB3		
}			
}			
}			

Condition	Explanation
DRX_S	Used for DRX configuration with small DRX cycle length
DRX_L	Used for DRX configuration with large DRX cycle length

Table 4.8.2.1.5-2: MAC-MainConfig-SRB

Derivation Path: 36.331 clause 6.3.2			
Information Element	Value/remark	Comment	Condition
MAC-MainConfig-SRB ::= SEQUENCE {			
ul-SCH-Config SEQUENCE {			
maxHARQ-Tx	n5		
periodicBSR-Timer	sf20		
retxBSR-Timer	sf320		
ttiBundling	FALSE		
}			
drx-Config CHOICE {			
release	NULL		
}			
timeAlignmentTimerDedicated	sf750		
phr-Config CHOICE {			
setup SEQUENCE {			
periodicPHR-Timer	sf500		
prohibitPHR-Timer	sf200		
dl-PathlossChange	dB3		
}			
}			
}			

4.8.2.1.6 Physical Layer configurations

Table 4.8.2.1.6-1: PhysicalConfigDedicated-DEFAULT

Derivation Path: 36.331 clause 6.3.2			
Information Element	Value/remark	Comment	Condition
PhysicalConfigDedicated-DEFAULT ::= SEQUENCE {			
pdsch-ConfigDedicated	PDSCH-ConfigDedicated-DEFAULT	See subclause 4.6.3	SRB1
	Not present		RBC
pucch-ConfigDedicated	PUCCH-ConfigDedicated-DEFAULT	See subclause 4.6.3	SRB1
	Not present		RBC
pusch-ConfigDedicated	PUSCH-ConfigDedicated-DEFAULT	See subclause 4.6.3	SRB1
	Not present		RBC
uplinkPowerControlDedicated	UplinkPowerControlDedicated-DEFAULT	See subclause 4.6.3	SRB1
	Not present		RBC
tpc-PDCCH-ConfigPUCCH	Not present		SRB1
	TPC-PDCCH-Config-DEFAULT using condition PUCCH	See subclause 4.6.3	RBC
tpc-PDCCH-ConfigPUSCH	Not present		SRB1
	TPC-PDCCH-Config-DEFAULT using condition PUSCH	See subclause 4.6.3	RBC
cqi-ReportConfig	CQI-ReportConfig-DEFAULT	See subclause 4.6.3	SRB1
	CQI-ReportConfig-DEFAULT using condition CQI_PERIODIC	See subclause 4.6.3	RBC
soundingRS-LU-ConfigDedicated	Not present		SRB1
	SoundingRS-ULI-ConfigDedicated-DEFAULT	See subclause 4.6.3	RBC
antennaInfo CHOICE {			
defaultValue	NULL		
}			
schedulingRequestConfig	SchedulingRequest-Config-DEFAULT	See subclause 4.6.3	SRB1
	Not present		RBC
}			

Condition	Explanation
SRB1	Used at configuration of SRB1 during RRC connection (re-)establishment
RBC	Used at configuration of a radio bearer combination during SRB2+DRB establishment

4.8.2.1.7 DRB configurations

Table 4.8.2.1.7-1: DRB-ToAddMod-DEFAULT(bid)

Derivation Path: 36.331 clause 6.3.2			
Information Element	Value/remark	Comment	Condition
DRB-ToAddMod-DEFAULT(bid) ::= SEQUENCE {		bid is the bearer identity (1..8)	
eps-BearerIdentity	bid+4		
drb-Identity	bid		
pdcp-Config	PDCP-Config-DRB-AM		AM
	PDCP-Config-DRB-UM		UM
rlc-Config	RLC-Config-DRB-AM		AM
	RLC-Config-DRB-UM		UM
logicalChannelIdentity	bid+2		
logicalChannelConfig	LogicalChannelConfig-DRB using condition HI		UM
	LogicalChannelConfig-DRB using condition LO		AM
}			

Condition	Explanation
AM	Used for AM DRB
UM	Used for UM DRB

4.8.2.2 SRB and DRB combinations

4.8.2.2.1 Combinations on DL-SCH and UL-SCH

4.8.2.2.1.1 SRB1 and SRB2 for DCCH + n x AM DRB + m x UM DRB, where n=1..N and m=0..M

This SRB and DRB combination is setup with UE Registration procedure and the Generic Radio Bearer Establishment or Generic Radio Bearer Establishment, UE Test Mode Activated procedure using specific message content - the default *RRCCConnectionReconfiguration* message with condition SRB2-DRB(n, m).

4.8.3 UTRA reference radio parameters and combinations

Table 4.8.3-1 defines UTRA reference radio parameters and combinations to be used in E-UTRA and UTRA inter-RAT test cases.

Table 4.8.3-1: UTRA reference radio parameters and combinations

Condition	Reference configuration	Comment
UTRA Speech	TS 34.108 subclause 6.10.2.4.1.4	Conversational / speech / UL:12.2 DL:12.2 kbps / CS RAB + UL:3.4 DL:3.4 kbps SRBs for DCCH
UTRA PS RB	TS 34.108 subclause 6.10.2.4.1.26	Interactive or background / UL:64 DL: 64 kbps / PS RAB + UL:3.4 DL:3.4 kbps SRBs for DCCH
UTRA HSPA RB	TS 34.108 subclause 6.10.2.4.5.1	Interactive or background / UL:64 DL: [max bit rate depending on UE category] / PS RAB + UL:3.4 DL:3.4 kbps SRBs for DCCH

4.8.4 GERAN reference PDP context parameters

Table 4.8.4-1 defines GERAN reference PDP context parameters to be used in E-UTRA and GERAN inter-RAT test cases.

Table 4.8.4-1: GERAN reference PDP context parameters

Condition	Reference configuration	Comment
GPRS	TS 51.010-1 subclause 40.5, Test PDP context3.	Test PDP context3 is the default Test PDP context which is used in the GERAN Inter-RAT GPRS test cases where no particular Test PDP contexts are specified. Compression is always turned off if nothing else is stated explicitly in the test case.

4.9 Common test USIM parameters

This clause defines default parameters for programming the elementary files of the test USIM when running conformance test cases defined in 3GPP TS 36.523-1[18].

4.9.1 General

See clause 8.1 in 3GPP TS 34.108 [5].

4.9.1.1 Definitions

See clause 8.1.1 in 3GPP TS 34.108 [5].

4.9.1.2 Definition of the test algorithm for authentication

Same as clause 8.1.2 in 3GPP TS 34.108[5].

4.9.1.2.1 Authentication and key derivation in the test USIM and SS

UE and SS calculate Ck, Ik, AUTN, RES[XRES] as in clause 8.1.2.1 in 3GPP TS 34.108 [5]. Derivation of K_{ASME} and other E-UTRA Keys shall be as defined in Annex A of 3GPP TS 33.401 [31], using Key derivation function HMAC-SHA-256 algorithm.

4.9.1.2.2 Generation of re-synchronization parameters in the USIM

Same as clause 8.1.2.1 in 3GPP TS 34.108[5].

4.9.1.2.3 Using the authentication test algorithm for UE conformance testing

See clause 8.1.2.3 in 3GPP TS 34.108 [5].

4.9.2 Default parameters for the test USIM

Same as clause 8.2 in 3GPP TS 34.108 [5].

4.9.3 Default settings for the Elementary Files (EFs)

The format and coding of elementary files of the USIM are defined in 3GPP TS 31.101 [32] and 3GPP TS 31.102 [33]. The following clauses define the default parameters to be programmed into each elementary file. Some files may be updated by the UE based on information received from the SS. These are identified in the following clauses.

If EFs have an unassigned value, it may not be clear from the main text what this value should be. This clause suggests values in these cases.

The settings of the the elementary files is the same as section 8.3 in 3GPP TS 34.108 [5] with the exceptions listed below:

- EF_{PLMNwACT}(User controlled PLMN selector with Access Technology):

Bytes 4 to 5: 40 00 (Access Technology) - Translates to E-UTRAN
 Bytes 9 to 10: 40 00 (Access Technology)

 Bytes (5n-1) to 5n: 40 00 (Access Technology)

EF_{EPSLOCI} (EPS location information)

File size: 18 Bytes

Default values: Bytes 1 to 12 (HEX): FF FF FF FF FF FF FF FF FF FF FF FF FF(GUTI)

Bytes 13 to 17 (HEX): 42 F6 18 FF FE (Last visited registered TAI)

Byte 18 (BIN): 00000001 (EPS update status = "not updated")

Bytes 13 to 17: TAI-MCC = 246 (bytes 13 to 14) and TAI-MNC = 81 (byte 15) are frequently used. The TAC (bytes 16 to 17) is set to "FF FE" since this, in conjunction with byte 18 setting of "01", is used to ensure that the UE performs Attach at the beginning of a test.

Bytes in this file (e.g. GUTI in bytes 1 to 12) may be updated as a result of a tracking area update attempt by the UE.

EF_{EPSNSC} (EPS NAS Security Context)

The programming of this EF follows default parameter written in 3GPP TS 31.102 [23], annex E.

- EF_{UST} (USIM Service Table):

Services		Activated	Version
Service n°15:	Cell Broadcast Message Identifier	Optional	
Service n°16:	Cell Broadcast Message Identifier Ranges	Optional	
Service n°85	EPS Mobility Management Information	Yes	
Service n°87	Call control on EPS PDN connection by USIM	No	

5 Test environment for RF test

This section contains all the exceptions of the common test parameters specified in clause 4 for specific needs of test cases defined in TS 36.521-1 [21].

5.1 Requirements of *test* equipment

No common RF test environment requirements are specified in addition to the common requirements described in clause 4.2. Specific RF requirements are indicated within the test cases defined in TS 36.521-1 [21].

5.2 RF/RRM Reference system configurations

5.2.1 Common parameters for simulated E-UTRA cells

5.2.1.1 Combinations of system information blocks

The combinations of system information blocks for test cases in TS 36.521-1 [21] is defined in table 5.2-1.1-1.

Table 5.2.1.1-1: Combinations of system information blocks

Combination No.	System information block type									
	SIB2	SIB3	SIB4	SIB5	SIB6	SIB7	SIB8	SIB9	SIB10	SIB11
1	X	X								
2	X	X	X							
3	X	X		X						
4	X	X			X					
5	X	X				X				
6	X	X					X			

5.2.1.2 Scheduling of system information blocks

The scheduling configurations for combinations of system information blocks are defined in the following tables. SIB1 will be transmitted during subframes#5 which SFN mod 2 = 0, and SIB2+SIB3 will be transmitted during subframes#5 which SFN mod 2 != 01 with 8 radio frames periodicity.

Table 5.2.1.2-1: Scheduling for combination 1

Scheduling Information No.	Periodicity [radio frames]	Mapping of system information blocks
1	8	SIB2, SIB3

Table 5.2.1.2-2: Scheduling for combination 2

Scheduling Information No.	Periodicity [radio frames]	Mapping of system information blocks
1	8	SIB2, SIB3
2	64	SIB4

Table 5.2.1.2-3: Scheduling for combination 3

Scheduling Information No.	Periodicity [radio frames]	Mapping of system information blocks
1	8	SIB2, SIB3
2	64	SIB5

Table 5.2.1.2-4: Scheduling for combination 4

Scheduling Information No.	Periodicity [radio frames]	Mapping of system information blocks
1	8	SIB2, SIB3
2	64	SIB6

Table 5.2.1.2-5: Scheduling for combination 5

Scheduling Information No.	Periodicity [radio frames]	Mapping of system information blocks
1	8	SIB2, SIB3
2	64	SIB7

Table 5.2.1.2-6: Scheduling for combination 6

Scheduling Information No.	Periodicity [radio frames]	Mapping of system information blocks
1	8	SIB2, SIB3
2	64	SIB8

5.2.1.2 Common contents of system information messages

- *MasterInformationBlock*

As defined in Table 4.4.3.2-1 without exceptions.

- *SystemInformation*

As defined in Table 4.4.3.2-2 without exceptions.

- *SystemInformationBlockType1*

As defined in Table 4.4.3.2-3 with the following exceptions:

Table 5.2.1.2-1: *SystemInformationBlockType1* exceptions

Derivation Path: 36.331 clause 6.2.2			
Information Element	Value/remark	Comment	Condition
...			
si-WindowLength	ms40		
...			

5.3 Default RRC message and information elements contents

5.4 Default NAS message and information elements contents

5.5 Reference radio bearer configurations

5.5.1 SRB and DRB parameters

5.5.1.1 Physical Layer configurations

Table 5.5.1.1-1: PhysicalConfigDedicated-DEFAULT

Derivation Path: 36.331 clause 6.3.2			
Information Element	Value/remark	Comment	Condition
PhysicalConfigDedicated-DEFAULT ::= SEQUENCE {			
pdsch-ConfigDedicated	PDSCH-ConfigDedicated-DEFAULT	See subclause 4.6.3	SRB1
	Not present		RBC
pucch-ConfigDedicated	PUCCH-ConfigDedicated-DEFAULT	See subclause 4.6.3	SRB1
	Not present		RBC
pusch-ConfigDedicated	PUSCH-ConfigDedicated-DEFAULT	See subclause 4.6.3	SRB1
	Not present		RBC
uplinkPowerControlDedicated	UplinkPowerControlDedicated-DEFAULT	See subclause 4.6.3	SRB1
	Not present		RBC
tpc-PDCCH-ConfigPUCCH	Not present		SRB1
	TPC-PDCCH-Config-DEFAULT using condition PUCCH	See subclause 4.6.3	RBC
tpc-PDCCH-ConfigPUSCH	Not present		SRB1
	TPC-PDCCH-Config-DEFAULT using condition PUSCH	See subclause 4.6.3	RBC
cqi-ReportConfig	Not present		SRB1
	Not present		RBC
soundingRS-LU-ConfigDedicated	Not present		SRB1
	Not present		RBC
antennaInfo CHOICE {			
defaultValue	NULL		
}			
schedulingRequestConfig	Not present		SRB1
	Not present	See subclause 4.6.3	RBC
}			

Condition	Explanation
SRB1	Used at configuration of SRB1 during RRC connection (re-)establishment
RBC	Used at configuration of a radio bearer combination during SRB2+DRB establishment

6 Test environment for Signalling test

6.1 Requirements of test equipment

The requirements of test equipment specified in this subclause apply to Signalling test cases defined in TS 36.523-1 [18], in addition to the common requirements of test equipment specified in clause 4.2 of this specification.

Test equipment shall be able to simulate cells of Radio Access Technology (RAT) E-UTRA, UTRA, GSM or HRPD / 1xRTT. Regardless of respective RAT, the overall number and configuration of cells to be simulated simultaneously by test equipment shall not exceed the resources specified in the following Table 6.1-1:

Table 6.1-1: Maximum resources in terms of number / configuration of cells to be simulated simultaneously in a test setup

Simulation of	Max. number / configuration of cells (SISO / SIMO)	Max. number / configuration of cells (MIMO)
E-UTRA single-mode networks (FDD or TDD)	3x cells	n/a
E-UTRA dual-mode networks (FDD and TDD)	3x cells	n/a
Mixed E-UTRA / UTRA networks	3x cells	n/a
Mixed E-UTRA / GSM networks	3x cells	n/a
Mixed E-UTRA / HRPD or 1xRTT networks	3x cells	n/a
Mixed E-UTRA / UTRA / GSM networks	3x cells	n/a
Note 1:	No differentiation between cell configuration types (as defined in clause 6.3.3) here, because these types are relevant to specific test cases and their TTCN-3 implementation only.	
Note 2:	Only network scenarios specified in clause 4.4.1 and 6.3.2.1 have been covered.	
Note 3:	MIMO configuration is not applied for Signalling tests regardless of UE MIMO functionality	

Exceptions to the outlined requirement of maximum 3 cells simultaneously need special evidence to be provided explicitly in the test case prose.

6.2 Reference test conditions

The reference test conditions specified in this subclause apply to all Signalling test cases defined in TS 36.523-1 [18] unless otherwise specified, in addition to the common reference test conditions specified in subclause 4.3 of this specification.

6.2.1 Physical channel allocations

6.2.1.1 Antennas

If the UE has two Rx antennas, the same downlink signal is applied to each one. Both UE Rx antennas shall be connected.

If the UE has one Rx antenna, the downlink signal is applied to it.

For signalling testing, SIMO (Single Input Multiple Output) is used. MIMO (Multiple Input Multiple Output) is not applied for all cell configurations regardless of UE MIMO functionality.

6.2.1.2 Downlink physical channels and physical signals

Same as clause 4.3.3.2

6.2.1.3 Mapping of downlink physical channels and signals to physical resources

Same as clause 4.3.3.3

6.2.1.4 Uplink physical channels and physical signals

[FFS].

6.2.1.5 Mapping of uplink physical channels and signals to physical resources

[FFS].

6.2.2 Signal levels

6.2.2.1 Downlink signal levels

The default settings of suitable cells and non-suitable cells for E-UTRA are specified in table 6.2.2.1-1.

Cells which are expected to be undetectable for UE under test shall fulfil the condition of non-suitable "Off" cell in table 6.2.2.1-1.

Table 6.2.2.1-1: Default settings of suitable / non-suitable cells for E-UTRA

Power level type / Parameter	Unit	Power level
Serving cell RS EPRE	dBm/15kHz	-85
Suitable neighbour intra-frequency cell RS EPRE	dBm/15kHz	-91
Suitable neighbour inter-frequency cell RS EPRE	dBm/15kHz	-97
Qrxlevmin	dBm	-106
Non-suitable cell RS EPRE	dBm/15kHz	-115
Non-suitable "Off" cell RS EPRE	dBm/15kHz	≤ -145
Note 1: The power level is specified in terms of cell-specific RS EPRE instead of RSRP as RSRP is a measured value and cannot be directly controlled by the SS.		
Note 2: Power levels are specified based on the precondition that q-Hyst, a3-Offset and hysteresis are 0 dB.		
Note 3: The power level is specified at each UE Rx antenna.		

The default signal level uncertainty is specified in table 6.2.2.1-2 for any level specified, unless a tighter uncertainty is specified by a test case in TS 36.523-1 [18].

Table 6.2.2.1-2: SS signal level uncertainty

	Absolute signal level uncertainty for each cell	Relative signal level uncertainty between multiple cells
Intra-frequency	+/-3 dB at each test port	+/-3 dB
Inter-frequency	+/-3 dB at each test port	See Note 1
Note 1: For Inter-frequency cells the relative signal level uncertainty between multiple cells is determined by the absolute uncertainty of each cell, and does not have any additional constraint.		

Cell-specific RS EPRE setting should be equal to or higher than -115 dBm except for Non-suitable "Off" cell. The figure is chosen to ensure that for all bands the DL signal is within the RSRP measurement range specified in TS 36.133 [39] clauses 9.1.2 and 9.1.3, taking into account the SS default absolute signal level uncertainty.

Noc (The power spectral density of a white noise source; specified in TS 36.133 [39]) can be assumed to be -Infinity [dBm/15kHz] for all intra and inter frequency test cases. It is applicable to both idle mode and connected mode in TS 36.523-1 [18], unless otherwise specified in specific test cases.

6.2.2.2 Measurement accuracy and side conditions

Measurement accuracy shall be considered in setting downlink power levels.

RSRP measurement accuracy in E-UTRA RRC_IDLE state is specified in table 6.2.2.2-1, derived from TS 36.133 [39] clauses 4.2.2.3 and 4.2.2.4. This measurement accuracy is applicable to idle mode test cases specified in TS 36.523-1 [18]. For the serving cell and suitable neighbour cells, the following side conditions shall be satisfied including the effect of signal level uncertainty.

- RSRP \geq -121 dBm
- RSRP $\hat{E}_s/I_{ot} \geq$ -4 dB
- SCH_RP \geq -121 dBm
- SCH $\hat{E}_s/I_{ot} \geq$ -4 dB

Table 6.2.2.2-1: RSRP measurement accuracy in E-UTRA RRC_IDLE state

	Absolute RSRP measurement accuracy	Relative RSRP measurement accuracy
Intra-frequency	+/-6 dB	+/-3 dB
Inter-frequency	+/-6 dB	+/-5 dB

RSRP measurement accuracy in E-UTRA RRC_CONNECTED state is specified in table 6.2.2.2-2, derived from TS 36.133 [39] clauses 9.1.2 and 9.1.3 selecting Normal condition. The ranges and side conditions in TS 36.133 [39] clauses 9.1.2 and 9.1.3 apply. This measurement accuracy is applicable to connected mode test cases specified in TS 36.523-1 [18]. For the serving cell and suitable neighbour cells, the following side conditions shall be satisfied including the effect of signal level uncertainty.

- RSRP \geq -124 dBm
- RSRP $\hat{E}_s/I_{ot} >$ -6 dB- I_o : -118 dBm/15kHz ... -70 dBm/BWChannel (for absolute RSRP measurement accuracy)
- I_o : -118 dBm/15kHz ... -50 dBm/BWChannel (for relative RSRP measurement accuracy)

Table 6.2.2.2-2: RSRP measurement accuracy in E-UTRA RRC_CONNECTED state

	Absolute RSRP measurement accuracy	Relative RSRP measurement accuracy
Intra-frequency	+/-6 dB	+/-3 dB
Inter-frequency	+/-6 dB	+/-6 dB

Signal level difference between the serving cell and any suitable intra-frequency neighbour cell shall be nominally 6 dB to satisfy the measurement accuracy requirement and its side conditions specified in TS 36.133 [39]. This figure is chosen based on the following preconditions for intra-frequency cells.

- Interference to reference signals from reference signals of other cells is eliminated by Physical Cell Identity shifting as specified in TS 36.523-3 [20].
- Interference to reference signals from PDSCH with SI-RNTI of other cells is negligible because it's sparse enough.
- Interference to reference signals from PDSCH of the serving cell is controlled by satisfying the conditions of clauses 6.2.2.1 and 6.2.2.2.
- Interference to P-SS/S-SS from P-SS/S-SS of other cells is eliminated by frame timing shifting as specified in TS 36.523-3 [20].
- Interference to P-SS/S-SS from PDSCH of other cells is eliminated by PDSCH resource allocation as specified in TS 36.523-3 [20].

6.3 Reference system configurations

The reference system configurations specified in this subclause apply to all Signalling test cases defined in TS 36.523-1 [18] unless otherwise specified, in addition to the common reference system configurations specified in subclause 4.4 of this specification.

For Signalling testing, MIMO (Multiple Input Multiple Output) is not applied for all cell configurations regardless of UE MIMO functionality. Only one SS Tx antenna is used.

One or two UE antennas are used for all signalling test cases. (*1)

(*1) Two UE antennas configuration is possible for UE diversity case.

6.3.1 Default parameter specific for simulated cells

Default parameters specific for simulated cells are specified in this subclause.

6.3.1.1 Intra-frequency neighbouring cell list in SIB4 for E-UTRA cells

Intra-frequency neighbouring cell list for signalling test cases is defined in table 6.3.1.1-1. This table is referred to in the default contents of IE *intraFreqNeighbouringCellList* in *SystemInformationBlockType4* defined in table 4.4.3.3-3.

Table 6.3.1.1-1: Intra-frequency neighbouring cell lists for E-UTRA cells

cell ID	Test Frequency	intra-frequency neighbouring cell list						
		number of entries	physCellId[n]			q-OffsetCell [n]		
			1	2	3	1	2	3
Cell 1	f1	3	Cell 2	Cell 4	Cell 11	dB0	dB0	dB0
Cell 2	f1	3	Cell 1	Cell 4	Cell 11	dB0	dB0	dB0
Cell 4	f1	3	Cell 1	Cell 2	Cell 11	dB0	dB0	dB0
Cell 11	f1	3	Cell 1	Cell 2	Cell 4	dB0	dB0	dB0
Cell 3	f2	1	Cell 23	-	-	dB0	-	-
Cell 23	f2	1	Cell 3	-	-	dB0	-	-

NOTE: The intra-frequency E-UTRA neighbouring cell list for signalling NAS test cases when cells are on same PLMN is defined in table 6.3.2.3.1-1.

6.3.1.2 Inter-frequency carrier frequency list in SIB5 for E-UTRA cells

Inter-frequency E-UTRA carrier frequency list for signalling test cases is defined in table 6.3.1.2-1. This table is referred to in the default contents of IE *interFreqCarrierFreqList* in *SystemInformationBlockType5* defined in table 4.4.3.3-4.

Table 6.3.1.2-1: Inter-frequency carrier frequency lists for E-UTRA cells

cell ID	Test Frequency	interFreqCarrierFreqList			
		number of entries	dl-CarrierFreq[n]		
			1	2	3
Cell 1 Cell 2 Cell 4 Cell 11	f1	3	f2	f3	f5
Cell 3 Cell 23	f2	3	f1	f3	f5
Cell 6	f3	3	f1	f2	f5
Cell 10	f5	3	f1	f2	f3

NOTE: The inter-frequency E-UTRA carrier frequency list for signalling NAS test cases when cells are on same PLMN is defined in table 6.3.2.3.2-1.

6.3.1.3 UTRA carrier frequency list in SIB6 for E-UTRA cells

UTRA carrier frequency list for signalling test cases is defined in table 6.3.1.3-1. This table is referred to in the default contents of IE *carrierFreqListUTRA-FDD* and *carrierFreqListUTRA-TDD* in *SystemInformationBlockType6* defined in table 4.4.3.3-5.

Table 6.3.1.3-1: UTRA carrier frequency lists for E-UTRA cells

interFreqCarrierFreqList			
number of entries	carrierFreq[n]		
	1	2	3
3	f8	f9	f10

Table 6.3.1.3-2: Mapping of UTRA cell with TS 34.108 [5]

UTRA cell	Frequency	UTRA cell in TS 34.108, clause 6.1	UTRA frequency in TS 34.108
Cell 5	f8	Cell 1	Mid
Cell 7	f8	Cell 2	Mid
Cell 8	f9	Cell 4	High
Cell 9	f10	Cell 7	Low

6.3.1.4 GERAN carrier frequency group list in SIB7 for E-UTRA cells

GERAN carrier frequency group list for signalling test cases is defined in table 6.3.1.4-1. This table is referred to in the default contents of IE *carrierFreqsInfoList* in *SystemInformationBlockType7* defined in table 4.4.3.3-6.

Table 6.3.1.4-1: GERAN carrier frequency group list for E-UTRA cells

carrierFreqsInfoList				
number of entries	index (n)	carrierFreqs[n]		
		startingARFCN[n]	explicitListOfARFCNs[n]	
			number of entries	ARFCN-ValueGERAN
3	1	f11	8	see Note
	2	f12	8	see Note
	3	f13	8	see Note

NOTE: The explicit list of ARFCNs for each cell uses the frequencies defined for the appropriate cell in the Neighbouring cells BCCH/CCCH carriers field in TS 51.010, clause 40.

Table 6.3.1.4-2: Mapping of GERAN cells with TS 51.010-1 [25]

GERAN cell	Frequency	GERAN cell in TS 51.010-1, clause 40
Cell 24	f11	Cell A
Cell 25	f12	Cell D
Cell 26	f13	Cell B

6.3.1.5 CDMA2000 HRPD carrier frequency list in SIB8 for E-UTRA cells

CDMA2000 HRPD carrier frequency list for signalling test cases is defined in table 6.3.1.5-1. This table is referred to in the default contents of IE *cellReselectionParametersHRPD* in *SystemInformationBlockType8* defined in table 4.4.3.3-7.

Table 6.3.1.5-1: CDMA2000 HRPD carrier frequency list for E-UTRA cells

neighCellsPerFreqList					
number of entries	index (n)	arfcn[n]	physCellIdList[n]		
			number of entries	index	PhysCellIdCDMA2000
3	1	f14	2	1	Cell 15
				2	Cell 16
	2	f15	1	1	Cell 17
				3	f16

6.3.1.6 CDMA2000 1xRTT carrier frequency list in SIB8 for E-UTRA cells

CDMA2000 1xRTT carrier frequency list for signalling test cases is defined in table 6.3.1.6-1. This table is referred to in the default contents of IE *cellReselectionParameters1XRTT* in *SystemInformationBlockType8* defined in table 4.4.3.3-7.

Table 6.3.1.6-1: CDMA2000 1xRTT carrier frequency list for E-UTRA cells

neighCellsPerFreqList					
number of entries	index (n)	arfcn[n]	physCellIdList[n]		
			number of entries	index	PhysCellIdCDMA2000
3	1	f17	2	1	Cell 19
				2	Cell 20
	2	f18	1	1	Cell 21
				3	Cell 22

6.3.1.7 E-UTRA carrier frequency list in SIB19 for UTRA cells

E-UTRA carrier frequency list for signalling test cases is defined in table 6.3.1.7-1. This table is referred to in the default contents of IE *eutra-FrequencyAndPriorityInfoList* in System Information Block type 19 defined in table 4.4.4.1-1.

Table 6.3.1.7-1: E-UTRA carrier frequency list for UTRA cells

eutra-FrequencyAndPriorityInfoList					
number of entries	earfcn[n]				
	1	2	3	4	5
5	f1	f2	f3	f4	f5

6.3.2 Default configurations for NAS test cases

The default configurations specified in this subclause apply only to NAS test cases. They apply to all NAS test cases unless otherwise specified.

6.3.2.1 Simulated network scenarios for NAS test cases

Simulated network scenarios for NAS test cases to be tested are listed below.

NOTE: The number of cells specified does not necessarily correspond to the maximum number of resources to be configured simultaneously in test equipment. Please refer to Table 6.1-1 for such information.

- Single cell network scenario

Cell A is used.

- Single PLMN multi cell network scenario

Cell A, Cell B and Cell C are used.

- Basic Multi PLMN multi cell network scenario

Cell A and Cell G are used.

6.3.2.2 Simulated NAS cells

Simulated NAS cells and default parameters are specified in table 6.3.2.2-1.

Cell A to Cell F have the same PLMN and separate TACs.

Cell G and Cell H have:

- The same MCC as Cell A to Cell F
- An MNC different from Cell A to Cell F
- Separate TACs

Cell I has an MCC different from Cell A to Cell H.

Cell J has an MCC different from Cell A to Cell I.

Cell K is the same as Cell I.

Cell L has the same PLMN as Cell I, but has a different TAC.

Cell M is the same as Cell A.

Unless otherwise specified, the default parameters specified in section 4 also apply to all NAS cells.

Table 6.3.2.2-1: Default parameters for simulated NAS cells

NAS cell ID	Tracking Area			TA# list (Note 1)	GUTI (Note 2)		M-TMSI	
	TA#	PLMN			TAC	MME Identifier		
		MCC	MNC			MME Group ID		MME Code
Cell A	TAI-1	(Note 3)		1	TAI-1	1	Arbitrarily selected according to TS 23.003 subclause 2.8 [2].	
Cell B	TAI-2	(Note 3)		2	TAI-2	1		
Cell C	TAI-3	(Note 3)		3	TAI-3	1		
Cell D	TAI-4	(Note 3)		4	TAI-4	1		
Cell E	TAI-5	(Note 3)		5	TAI-5	1		
Cell F	TAI-6	(Note 3)		6	TAI-6	1		
Cell G	TAI-7	(Note 4)	02	1	TAI-7	1		
Cell H	TAI-8	(Note 4)	02	2	TAI-8	1		
Cell I	TAI-9	002	101	1	TAI-9	1		
Cell J	TAI-10	003	101	1	TAI-10	1		
Cell K	TAI-9	002	101	1	TAI-9	1		
Cell L	TAI-11	002	101	2	TAI-11	1		
Cell M	TAI-1	(Note 3)		1	TAI-1	1		

NOTE 1: The value(s) in the column TA# list indicates TAI(s) included in the response messages of the registration procedure (ATTACH ACCEPT or TRACKING AREA UPDATE ACCEPT) when the UE performs the registration procedure on a corresponding cell.

NOTE 2: The value in the column GUTI indicates GUTI included in the response messages of the registration procedure (ATTACH ACCEPT or TRACKING AREA UPDATE ACCEPT) when the UE performs the registration procedure on a corresponding cell.

NOTE 3: Set to the same Mobile Country Code and Mobile Network Code stored in EF_{IMSI} on the test USIM card (subclause 4.9.3).

NOTE 4: Set to the same Mobile Country Code stored in EF_{IMSI} on the test USIM card (subclause 4.9.3).

NOTE 5: Cell A is a serving cell and the other cells are suitable neighbour cells. The definitions are specified in subclause 6.2.2.1.

Table 6.3.2.2-2: Default cell identifiers for simulated NAS cells when cells are on same PLMN

NAS cell ID	Frequency	E-UTRAN Cell Identifier		Physical layer cell identity
		eNB Identifier	Cell Identity	

Cell A	f1	'0000 0000 0000 0001 0001'B	'0000 0001'B	1
Cell B	f1	'0000 0000 0000 0001 0001'B	'0000 0010'B	2
Cell C	f2	'0000 0000 0000 0001 0010'B	'0000 0011'B	3
Cell D	f1	'0000 0000 0000 0001 0001'B	'0000 0100'B	4
Cell E	f3	'0000 0000 0000 0001 0011'B	'0000 0110'B	6
Cell F	f2	'0000 0000 0000 0001 0010'B	'0000 1010'B	10
Cell G	NA	NA	NA	NA
Cell H	NA	NA	NA	NA
Cell I	NA	NA	NA	NA
Cell J	NA	NA	NA	NA

6.3.2.3 Broadcast system information

6.3.2.3.1 Intra-frequency neighbouring cell list in SIB4 for E-UTRA NAS cells

Intra-frequency neighbouring cell list of the same PLMN for the NAS signalling test is defined in table 6.3.2.3.1-1 when SIB4 to be broadcast.

Table 6.3.2.3.1-1: Intra-freq. lists in SIB4 for NAS test cases (same PLMN)

NAS cell ID	Test Frequency	Intra-frequency neighbouring cell list		
		number of entries	physCellId[n]	
			1	2
Cell A	f1	2	Cell B	Cell D
Cell B	f1	2	Cell A	Cell D
Cell D	f1	2	Cell A	Cell B
Cell C	f2	1	Cell F	N/A
Cell F	f2	1	Cell C	N/A

6.3.2.3.2 Inter-frequency carrier frequency list in SIB5 for E-UTRA NAS cells

Inter-frequency neighbouring carrier and cell lists for NAS signalling test cases when on same PLMN are defined in table 6.3.2.3.2-1.

Table 6.3.2.3.2-1: Inter-freq. lists in SIB5 for NAS test cases (same PLMN)

NAS cell ID	Test Frequency	interFreqCarrierFreqList		
		number of entries	dl-CarrierFreq[n]	
			1	2
Cell A Cell B Cell D	f1	2	f2	f3
Cell C Cell F	f2	2	f1	f3
Cell E	f3	2	f1	f2

6.3.3 Cell configurations

For the purpose of test, three types of SS cell configurations are defined, full (Active) cell configuration, broadcast only cell configuration and minimum uplink cell configuration.

6.3.3.1 Full cell configuration

Full cell configuration is also called active cell configuration. The cell configuration, in minimum, has all defined DL and UL physical channels configured, i.e.

in DL: PBCH, PCFICH, PDCCH, PDSCH, PHICH,

in UL: PRACH, PUCCH, PUSCH.

The DL and UL Reference and synchronization (both primary and secondary) signals are also configured.

6.3.3.2 Minimum uplink cell configuration

In this cell configuration,

in DL: physical channels capable of transmission, i.e. PBCH, PCFICH, PDCCH, PDSCH are configured;

DL physical reference and synchronization (both primary and secondary) signals are also configured.

In UL: PRACH is configured. SS shall report any detection of PRACH preambles, in order to assign test verdicts. Decoding the preambles is not required.

6.3.3.3 Broadcast only cell configuration

In this cell configuration,

in DL: physical channels capable of transmission, i.e. PBCH, PCFICH, PDCCH, PDSCH are configured;

DL physical reference and synchronization (both primary and secondary) signals are also configured.

in UL: no physical resources are configured, neither channels, nor signals.

6.3.3.4 Application of different cell configurations

By default, the cells specified in 36.523-1 are defined with the full cell configuration, unless it is explicitly specified as either the broadcast only, or the minimum uplink cell configuration. The full cell configuration is suitable for UE to start camping, establish RRC connection or hand over from another active cell.

The broadcast only cells can be applied in some RRC measurement test cases to those neighbour cells which UE shall not camp on during the test case execution.

The capability of a minimum uplink cell is much weaker than a full cell, but stronger than a broadcast only cell in UL. This cell configuration can be applied in the idle mode test cases to those neighbour cells which a conformant UE shall not camp on during the test case execution.

If a cell configuration is specified in a test case it shall remain unchanged throughout the test case specification. In addition, there shall not be any requirement in the test specification or test implementation for a cell reconfiguration from one of the above configurations to the other.

For the UE conformance test, the broadcast only cell configuration can be replaced and implemented with the other two configurations. The minimum uplink cell configuration can also be implemented with the full cell configuration. The replacements in the implementation have no impact on the test purposes and the test requirements. The implementation guidelines are referred to 36.523-3.

6.4 Generic procedures

This clause describes UE test states which can be used in the initial condition of many test cases defined in TS 36.523-1 [18] in addition to the states already specified in clause 4.5 of this specification.

6.4.1 Initial UE states and setup procedures

6.4.1.1 Initial UE states and setup procedures

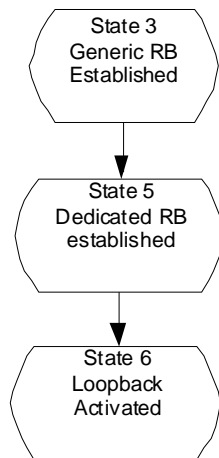

Figure 6.4.1.1-1: Initial UE states

In order that the UE can set up a call or session in E-UTRAN, there are a number of setup procedures to be undertaken in a hierarchical sequence to move between known states. The sequences are shown in figure 6.4.1.1-1 and the status of the relevant protocols in the UE in the different states are given in table 6.4.1.1-1. State 3 is defined in clause 4.5.1.

Table 6.4.1.1-1: Protocol state for each initial UE state

		RRC	ECM	EMM	ESM
State 5	Dedicated RB established	RRC_CONNECTED	ECM_CONNECTED	EMM-REGISTERED	1 default EPS bearer context active N dedicated EPS bearer context(s) active
State 6	Loopback Activated	RRC_CONNECTED	ECM_CONNECTED	EMM-REGISTERED	1 default EPS bearer context active N dedicated EPS bearer context(s) active

6.4.1.2 Dedicated Bearer Establishment (to state 5)

6.4.1.2.1 Initial conditions

System Simulator:

- Parameters are set to the default parameters for the basic single cell environment, as defined in subclause 4.4, unless otherwise specified in the test case.

User Equipment:

- The UE shall be in Generic RB established (State 3).

6.4.1.2.2 Definition of system information messages

The default system information messages are used.

6.4.1.2.3 Procedure

The establishment of dedicated radio bearer connection is assumed to always be mobile terminated.

Table 6.4.1.2.3-1: Procedure for dedicated bearer establishment

Step	Procedure	Message Sequence	
		U - S	Message
1	The SS configures new data radio bearer(s) and the associated dedicated EPS bearer context(s).	<--	RRC: RRCConnectionReconfiguration NAS: ACTIVATE DEDICATED EPS BEARER CONTEXT REQUEST
2	The UE transmits a <i>RRCConnectionReconfigurationComplete</i> message to confirm the establishment of the new data radio bearer(s), associated with the dedicated EPS bearer context(s) in the NAS message.	-->	RRC: RRCConnectionReconfigurationComplete
3	The UE transmits a ACTIVATE DEDICATED EPS BEARER CONTEXT ACCEPT message.	-->	NAS: ACTIVATE DEDICATED EPS BEARER CONTEXT ACCEPT

6.4.1.2.4 Specific message contents

All specific message contents shall be referred to clause 4.6 and 4.7.

6.4.1.3 Loopback Activation (to state 6)

Editor's Note: This section will be completed when message for loopback activation is defined in TS 36.509. The table below is just an example and should be aligned with TS 36.509.

6.4.1.3.1 Initial conditions

System Simulator:

- Parameters are set to the default parameters for the basic single cell environment, as defined in subclause 4.4, unless otherwise specified in the test case.

User Equipment:

- The UE shall be in Dedicated Radio Bearer Established (State 5).

6.4.1.3.2 Definition of system information messages

The default system information messages are used.

6.4.1.3.3 Procedure

Table 6.4.1.3.3-1: Procedure for loopback activation

Step	Procedure	Message Sequence	
		U - S	Message
1	The SS transmits an ACTIVATE RB TEST MODE message to activate UE radio bearer test mode procedure.	<--	RRC: DLInformationTransfer TC: ACTIVATE RB TEST MODE
2	The UE transmits an ACTIVATE RB TEST MODE COMPLETE message.	-->	RRC: ULInformationTransfer TC: ACTIVATE RB TEST MODE COMPLETE
3	The SS transmits a CLOSE UE TEST LOOP message to enter the UE test loop mode.	<--	RRC: DLInformationTransfer TC: CLOSE UE TEST LOOP
4	The UE transmits a CLOSE UE TEST LOOP COMPLETE message to confirm that loopback entities for the radio bearer(s) have been created and loop back is activated (State 6).	-->	RRC: ULInformationTransfer TC: CLOSE UE TEST LOOP COMPLETE

6.4.1.3.4 Specific message contents

All specific message contents shall be referred to clause 4.6, 4.7 and 4.7A.

6.4.2 Test procedures

6.4.2.1 Introduction

This section defines test procedures which can be used within test procedure sequences for test steps where checking the UE state is needed.

For each test procedure,

- at the start of the test procedure,
- the System Simulator condition and the value of system information messages are the ones applicable in the test case referring to this test procedure, as they are after the execution of the test step immediately preceding the test step where the test procedure is used;
- the initial UE condition is one indicated in the test case referring to this procedure, as it is after the execution of the test step immediately preceding the test step where the test procedure is used.
- at the end of the test procedure,
- the System Simulator condition after the test procedure execution is complete is the same as before it is started (this should not be changed by the test procedure).

6.4.2.2 Test procedure to check RRC_IDLE state

This procedure aims at checking whether the UE is in RRC_IDLE on a certain cell of a test case or not.

Table 6.4.2.2-1: Test procedure sequence

St	Procedure	Message Sequence		TP	Verdict
		U - S	Message/PDU/SDU		
1	The SS sends RRC <i>Paging</i> message with UE S-TMSI on the cell(s) specified in the test case.	<--	RRC: <i>Paging</i> (PCCH)	-	-
2	Check: Does the UE send a <i>RRCConnectionRequest</i> message on the cell specified in the test case ?	-->	RRC: <i>RRCConnectionRequest</i>		P
3	The SS transmits a <i>RRCConnectionSetup</i> message	<--	RRC: <i>RRCConnectionSetup</i>	-	-
4	The UE transmits a <i>RRCConnectionSetupComplete</i> message to confirm the successful completion of the connection establishment and to initiate the session management procedure by including the SERVICE REQUEST message.	-->	RRC: <i>RRCConnectionSetupComplete</i> NAS: Service Request	-	-
5	The SS transmits a SERVICE REJECT with cause set to "congestion" to indicate UE to terminate Service Request procedure	<--	RRC: <i>ULInformationTransfer</i> NAS: Service Reject	-	-
6	The SS transmits a <i>RRCConnectionRelease</i> message to release RRC connection and move to RRC_IDLE.	<--	RRC: <i>RRCConnectionRelease</i>	-	-

6.4.2.3 Test procedure to check RRC_CONNECTED state

Table 6.4.2.3-1: Test procedure sequence

St	Procedure	Message Sequence		TP	Verdict
		U - S	Message/PDU/SDU		
1	The SS sends <i>UECapabilityEnquiry</i> message to the UE.	<--	<i>UECapabilityEnquiry</i>	-	-
2	Check: Does the UE send a <i>UECapabilityInformation</i> message?	-->	<i>UECapabilityInformation</i>		P

6.4.2.4 Test procedure Paging (for NAS testing)

This procedure aims at checking whether the UE is in registered with a certain S-TMSI.

This procedure is identical to the procedure in 6.4.2.2 except that the S-TMSI as indicated in step 1 is the one explicitly specified in the test step calling this procedure.

6.4.2.5 Test procedure for no response to paging (for NAS testing)

This procedure aims at checking that the UE ignores paging messages with a specified identity.

The procedure is defined in table 6.4.2.5-1.

Table 6.4.2.5-1: Test procedure sequence

St	Procedure	Message Sequence		TP	Verdict
		U - S	Message		
1	The SS transmits a paging message using the UE identity and the CN domain which are both specified in the referring test step, and on the cell which is specified in the referring test step.	<--	Paging	-	-
2	Check: Does the UE send a <i>RRCConnectionRequest</i> message on the cell where the paging was transmitted within the next 3s?	-->	<i>RRCConnectionRequest</i>		F

6.4.2.6 Test procedure to check that a dedicated EPS bearer context is active (for NAS testing)

This procedure aims at checking that a dedicated EPS bearer context is active.

The procedure is defined in table 6.4.2.6-1.

Table 6.4.2.6-1: Test procedure sequence

St	Procedure	Message Sequence		TP	Verdict
		U - S	Message		
1	The SS modifies existing data radio bearer(s) and the associated EPS bearer context(s) with Bearer QoS update.	<--	RRC: <i>RRCConnectionReconfiguration</i> NAS: MODIFY EPS BEARER CONTEXT REQUEST	-	-
2	The UE transmits a <i>RRCConnectionReconfigurationComplete</i> message to confirm the modification of the existing data radio bearer(s), associated with the EPS bearer context(s) in the NAS message.	-->	RRC: <i>RRCConnectionReconfigurationC</i> <i>omplete</i>	-	-
3	Check: Does the UE transmit a MODIFY EPS BEARER CONTEXT ACCEPT message?	-->	RRC: <i>ULInformationTransfer</i> NAS: MODIFY EPS BEARER CONTEXT ACCEPT		P

6.4.2.7 Test procedure to check that UE is camped on a new E-UTRAN cell

This procedure aims at checking whether the UE is camping on a new E-UTRAN cell with different TAI of a test case or not.

The procedure is defined in table 6.4.2.7-1.

Table 6.4.2.7-1: Test procedure sequence

St	Procedure	Message Sequence		TP	Verdict
		U - S	Message		
1	Check: Does the UE send a <i>RRCCONNECTIONREQUEST</i> message on the cell specified in the test case?	-->	RRC: <i>RRCCONNECTIONREQUEST</i>	-	P
2	SS transmit an <i>RRCCONNECTIONSETUP</i> message.	<--	RRC: <i>RRCCONNECTIONSETUP</i>	-	-
3	The UE transmits a <i>RRCCONNECTIONSETUPCOMPLETE</i> message to confirm the successful completion of the connection establishment and a TRACKING AREA UPDATE REQUEST message is sent to update the registration of the actual tracking area.	-->	RRC: <i>RRCCONNECTIONSETUPCOMPLETE</i> NAS: TRACKING AREA UPDATE REQUEST	-	-
4	SS responds with TRACKING AREA UPDATE ACCEPT message.	<--	RRC: <i>DLINFORMATIONTRANSFER</i> NAS: TRACKING AREA UPDATE ACCEPT	-	-
5	The UE transmits a TRACKING AREA UPDATE COMPLETE	-->	RRC: <i>ULINFORMATIONTRANSFER</i> NAS: TRACKING AREA UPDATE COMPLETE	-	-
6	The SS transmits an <i>RRCCONNECTIONRELEASE</i> message to release RRC connection and move to RRC_IDLE.	<--	RRC: <i>RRCCONNECTIONRELEASE</i>	-	-

NOTE 1: The periodic tracking area updating timer T3412 is deactivated by default during the attach procedure (TS 36.508 clause 4.7.2).

NOTE 2: The SS does not initiate authentication and NAS SECURITY MODE COMMAND are not performed (reuse of keys allocated during the attach procedure).

6.4.2.8 Test procedure to check that UE is camped on a new UTRAN cell

This procedure aims at checking whether the UE is camping on a new UTRAN cell of a test case or not.

The procedure is defined in table 6.4.2.8-1.

Table 6.4.2.8-1: Test procedure sequence

St	Procedure	Message Sequence		TP	Verdict
		U - S	Message		
1	Check: Does the UE send a RRC CONNECTION REQUEST message on the cell specified in the test case?	-->	RRC CONNECTION REQUEST	-	P
2	The SS transmits an RRC CONNECTION SETUP message.	<--	RRC CONNECTION SETUP	-	-
3	The UE transmits an RRC CONNECTION SETUP COMPLETE message.	-->	RRC CONNECTION SETUP COMPLETE	-	-
4	The UE transmits an INITIAL DIRECT TRANSFER message. This message includes a ROUTING AREA UPDATE REQUEST message.	-->	INITIAL DIRECT TRANSFER	-	-
5	The SS transmits a DOWNLINK DIRECT TRANSFER message. This message includes an AUTHENTICATION AND CIPHERING REQUEST message.	<--	DOWNLINK DIRECT TRANSFER	-	-
6	The UE transmits an UPLINK DIRECT TRANSFER message. This message includes an AUTHENTICATION AND CIPHERING RESPONSE message.	-->	UPLINK DIRECT TRANSFER	-	-
7	The SS transmits a SECURITY MODE COMMAND message.	<--	SECURITY MODE COMMAND	-	-
8	The UE transmits a SECURITY MODE COMPLETE message.	-->	SECURITY MODE COMPLETE	-	-
9	The SS transmits a DOWNLINK DIRECT TRANSFER message. This message includes a ROUTING AREA UPDATE ACCEPT message.	<--	DOWNLINK DIRECT TRANSFER	-	-
10	The UE transmits an UPLINK DIRECT TRANSFER message. This message includes a ROUTING AREA UPDATE COMPLETE message.	-->	UPLINK DIRECT TRANSFER	-	-
11	The SS transmits an RRC CONNECTION RELEASE message.	<--	RRC CONNECTION RELEASE	-	-
12	The UE transmits an RRC CONNECTION RELEASE COMPLETE message.	-->	RRC CONNECTION RELEASE COMPLETE	-	P

NOTE: The TS 34.108 [5] and TS 34.123-1 [7] use Network Mode of Operation I as default, for this reason a combined MM/GMM procedure is performed.

6.4.2.9 Test procedure to check that UE is camped on a new GERAN cell

This procedure aims at checking whether the UE is camping on a new GERAN cell of a test case or not.

The procedure is defined in table 6.4.2.9-1.

Table 6.4.2.9-1: Test procedure sequence

St	Procedure	Message Sequence		TP	Verdict
		U - S	Message		
1	Check: Does the UE send a CHANNEL REQUEST message on the cell(s) specified in the test case?	-->	CHANNEL REQUEST	-	P
2	An uplink TBF is established in order to allow the UE to transmit a ROUTING AREA UPDATE REQUEST message signalling.	-	-	-	-
3	The UE transmits a ROUTING AREA UPDATE REQUEST message.	-->	ROUTING AREA UPDATING REQUEST	-	-
4	A downlink TBF is established by the SS in order to transmit the AUTHENTICATION AND CIPHERING REQUEST message	-	-	-	-
5	The SS transmits an AUTHENTICATION AND CIPHERING REQUEST message.	<--	AUTHENTICATION AND CIPHERING REQUEST	-	-
6	An uplink TBF is established in order to allow the UE to transmit an AUTHENTICATION AND CIPHERING RESPONSE message	-	-	-	-
7	The UE transmits a AUTHENTICATION AND CIPHERING RESPONSE message.	-->	AUTHENTICATION AND CIPHERING RESPONSE	-	-
8	A downlink TBF is established by the SS in order to transmit the ROUTING AREA UPDATE ACCEPT message	-	-	-	-
9	The SS transmits a ROUTING AREA UPDATE ACCEPT message.	<--	ROUTING AREA UPDATING ACCEPT	-	-
10	An uplink TBF is established in order to allow the UE to transmit a ROUTING AREA UPDATE COMPLETE message			-	-
11	The UE transmits a ROUTING AREA UPDATE COMPLETE message.	-->	ROUTING AREA UPDATING COMPLETE	-	P

NOTE: The TS 51.010-1 [25] uses Network Mode of Operation I as default, for this reason a combined MM/GMM procedure is performed.

6.5 Default RRC message and information element contents

The default RRC message and information element contents specified in this subclause apply to all Signalling test cases defined in TS 36.523-1 [18] unless otherwise specified, in addition to the default RRC message and information element contents specified in subclause 4.6 of this specification.

6.6 Default NAS message and information element contents

The default NAS message and information element contents specified in this subclause apply to all Signalling test cases defined in TS 36.523-1 [18] unless otherwise specified, in addition to the default NAS message and information element contents specified in subclause 4.7 of this specification.

6.6.1 Reference default EPS bearer contexts

The following table defines Reference default EPS bearer contexts. Default EPS bearer context1 is the default "default EPS bearer context" which is used in the common procedures and test cases where no particular default EPS bearer context is specified.

Table 6.6.1-1: Reference default EPS bearer contexts

Parameters	Reference default EPS bearer context #1	Reference default EPS bearer context #2	Reference default EPS bearer context #3
EPS QoS			
QCI (Note 1)	9 (non-GBR QCI)	FFS	FFS
Maximum bit rate for uplink	64 kbps (Note 2)	FFS	FFS
Maximum bit rate for downlink	64 kbps (Note 2)	FFS	FFS
Guaranteed bit rate for uplink	64 kbps (Note 2)	FFS	FFS
Guaranteed bit rate for downlink	64 kbps (Note 2)	FFS	FFS
Maximum bit rate for uplink (extended)	0	FFS	FFS
Maximum bit rate for downlink (extended)	0	FFS	FFS
Guaranteed bit rate for uplink (extended)	0	FFS	FFS
Guaranteed bit rate for downlink (extended)	0	FFS	FFS
APN	Arbitrarily chosen	FFS	FFS
PDN address	Static	FFS	FFS
Negotiated QoS	Note 3	FFS	FFS
Negotiated LLC SAPI	Note 3	FFS	FFS
Radio priority	Note 3	FFS	FFS
APN-AMBR	Not present	FFS	FFS
Protocol configuration options	PPP	FFS	FFS
Note 1: For all non-GBR QCIs, the maximum and guaranteed bit rates shall be ignored.			
Note 2: According to TS 24.301, the UE ignores these parameters for a non-GBR QCI.			
Note 3: Parameters included for UEs capable of UTRAN and/or GERAN according to TS 51.010 clause 40.5 – Test PDP Context 2			

6.6.2 Reference dedicated EPS bearer contexts

The following table defines Reference dedicated EPS bearer contexts. Dedicated EPS bearer context #1 is the default "dedicated EPS bearer context" which is used in the common procedures and test cases where no particular dedicated EPS bearer context is specified.

Table 6.6.2-1: Reference dedicated EPS bearer contexts

Parameters	Reference dedicated EPS bearer context #1	Reference dedicated EPS bearer context #2	Reference dedicated EPS bearer context #3
Linked EPS bearer identity	Reference default EPS bearer #1	Reference default EPS bearer #1	FFS
EPS QoS			
QCI (Note 1)	4 (GBR QCI)	5 (non-GBR QCI)	FFS
Maximum bit rate for uplink	384 kbps	384 kbps (Note 2)	FFS
Maximum bit rate for downlink	384 kbps	384 kbps (Note 2)	FFS
Guaranteed bit rate for uplink	128 kbps	128 kbps (Note 2)	FFS
Guaranteed bit rate for downlink	128 kbps	128 kbps (Note 2)	FFS
Maximum bit rate for uplink (extended)	0	0	FFS
Maximum bit rate for downlink (extended)	0	0	FFS
Guaranteed bit rate for uplink (extended)	0	0	FFS
Guaranteed bit rate for downlink (extended)	0	0	FFS
TFT			
TFT operation code	"create new TFT"	"create new TFT"	FFS
E bit	0	0	FFS
Number of packet filters	0 (Note 4)	1	FFS
Packet filter identifier 1	N/A	1	FFS
Packet filter evaluation precedence 1	N/A	0	FFS
Packet filter contents 1	N/A	- IPv4 or IPv6 source address type: fixed - Protocol identifier - Destination port range type: * - Source port range type: *	FFS
Negotiated QoS	Note 3	Note 3	FFS
Negotiated LLC SAPI	Note 3	Note 3	FFS
Radio priority	Note 3	Note 3	FFS
Protocol configuration options	PPP	PPP	FFS
<p>Note 1: For all non-GBR QCIs, the maximum and guaranteed bit rates shall be ignored.</p> <p>Note 2: According to TS 24.301, the UE ignores these parameters for a non-GBR QCI.</p> <p>Note 3: Parameters included for UEs capable of UTRAN and/or GERAN according to TBD (TS 51.010 clause 40.5 has no Test PDP Contexts for conversational traffic class)</p> <p>Note 4: It may be necessary to provide packet filters for GBR QCI bearers (FFS).</p>			

6.7 Timer Tolerances

The timer tolerances specified in this subclause apply to all Signalling test cases defined in TS 36.523-1 [18] unless otherwise specified

All the timers used during testing are within a tolerance margin given by the equation below. If for a specific test a different tolerance value is required then this should be specified in the relevant test document (i.e. the document where the test is described).

Timer tolerance = 10%, or $5 \times RTT$, whichever value is the greater.

Where $RTT = 8$ TTIs for FDD, and $RTT =$ Maximum RTT from Table 6.7-1 for TDD (see Note).

NOTE: Since the exact RTT for TDD varies depending on the UL/DL configurations and subframe number [29], the maximum RTT is defined in Table 6.7-1.

Table 6.7-1: Maximum RTT for TDD UL/DL configurations

UL/DL Configuration	Maximum RTT (TTIs)
0	10
1*	11
2	12
3	15
4	16
5	TBD
6	11

*Note: Default UL/DL configuration defined in Table 4.6.3-23 of TS 36.508

Annex A (informative): Connection Diagrams

Definition of Terms

System Simulator or SS – A device or system, that is capable of generating simulated Node B signalling and analysing UE signalling responses on one or more RF channels, in order to create the required test environment for the UE under test. It will also include the following capabilities:

1. Measurement and control of the UE Tx output power through TPC commands
2. Measurement of Throughput
3. Measurement of signalling timing and delays
4. Ability to simulate UTRAN and/or E-UTRAN and/or GERAN signalling

Test System – A combination of devices brought together into a system for the purpose of making one or more measurements on a UE in accordance with the test case requirements. A test system may include one or more System Simulators if additional signalling is required for the test case. The following diagrams are all examples of Test Systems.

NOTE: The above terms are logical definitions to be used to describe the test methods used in the documents TS36.521-1, TS 36.523-1 and TS36.521-3 in practice, real devices called 'System Simulators' may also include additional measurement capabilities or may only support those features required for the test cases they are designed to perform.

NOTE: Components in the connection diagrams:

The components in the connection diagrams represent ideal components. They are intended to display the wanted signal flow. They don't mandate real implementations. An alternative to Fig. A3 is shown below as an example: It is nearer to real implementations. The signal levels are the same as in Fig. A3. The signal flow cannot be displayed as detailed as in Fig. A.3.

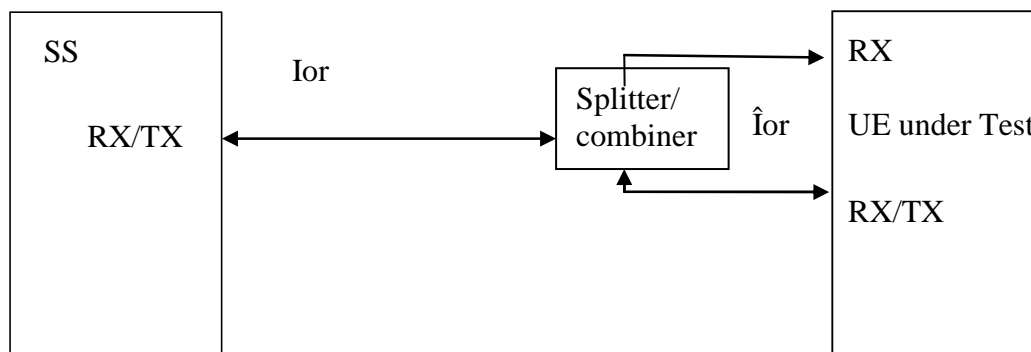

Alternative to Fig A.3

Connection: Each connection is displayed as a one or two sided arrow, showing the intended signal flow.

Circulator: The signal, entering one port, is conducted to the adjacent port, indicated by the arrow. The attenuation among the above mentioned ports is ideally 0 and the isolation among the other ports is ideally ∞ .

Splitter: a splitter has one input and 2 or more outputs. The signal at the input is equally divided to the outputs. The attenuation from input to the outputs is ideally 0 and the isolation between the outputs is ideally ∞ .

Combiner: a combiner has one output and 2 or more inputs. The signals at the inputs are conducted to the output, all with the same, ideally 0 attenuation. The isolation between the inputs is ideally ∞ .

Switch: contacts a sink (or source) alternatively to two or more sources (or sinks).

Fader: The fader has one input and one output. The MIMO fading channel is represented by several single faders (e.g. 8 in case of a MIMO antenna configuration 4x2) The correlation among the faders is described in TS 36.521-1 clause B.2.2

Attenuator: tbd

Figure A.1: Void

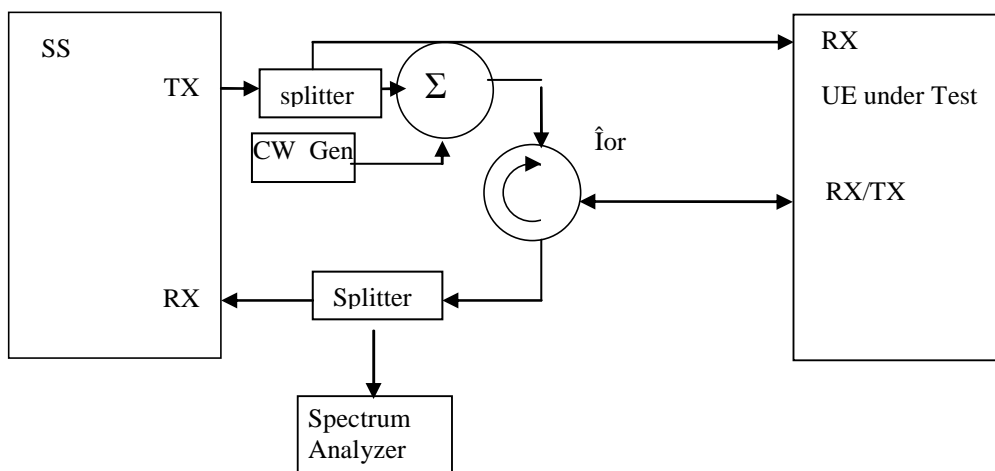

Figure A.2: Connection for Transmitter Intermodulation tests

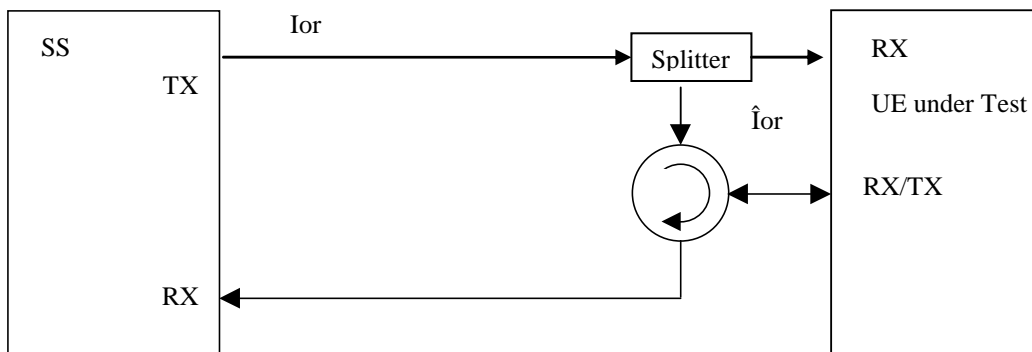

Figure A.3: Connection for basic single cell, RX and TX tests

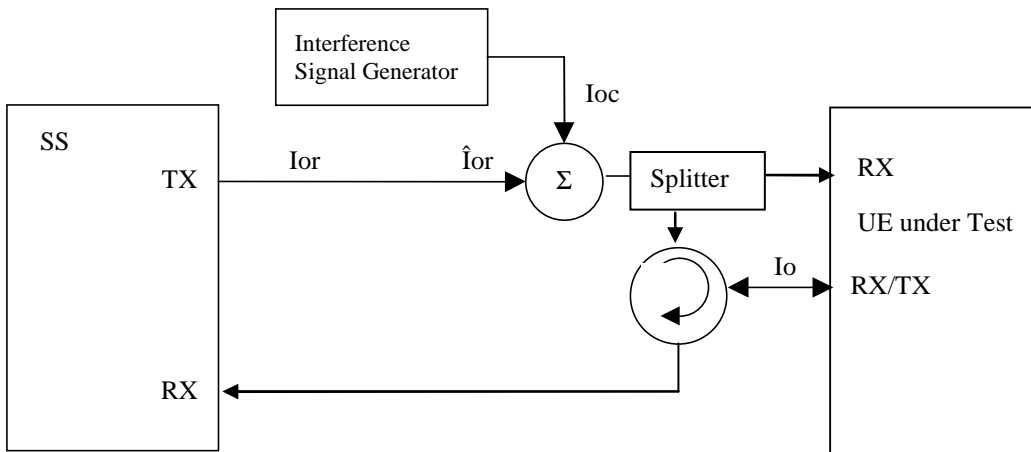

Figure A.4: Connection for Receiver tests with E-UTRA-Interference

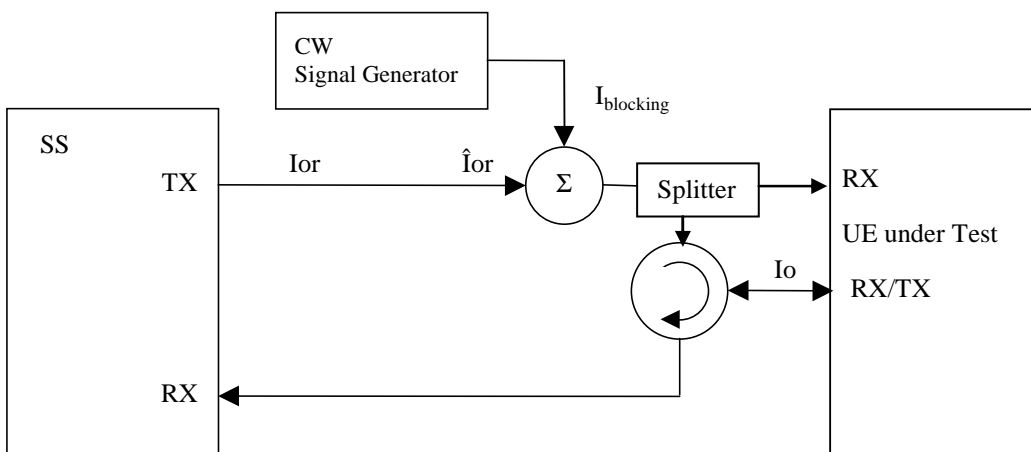

Figure A.5: Connection for Receiver tests with CW interferer

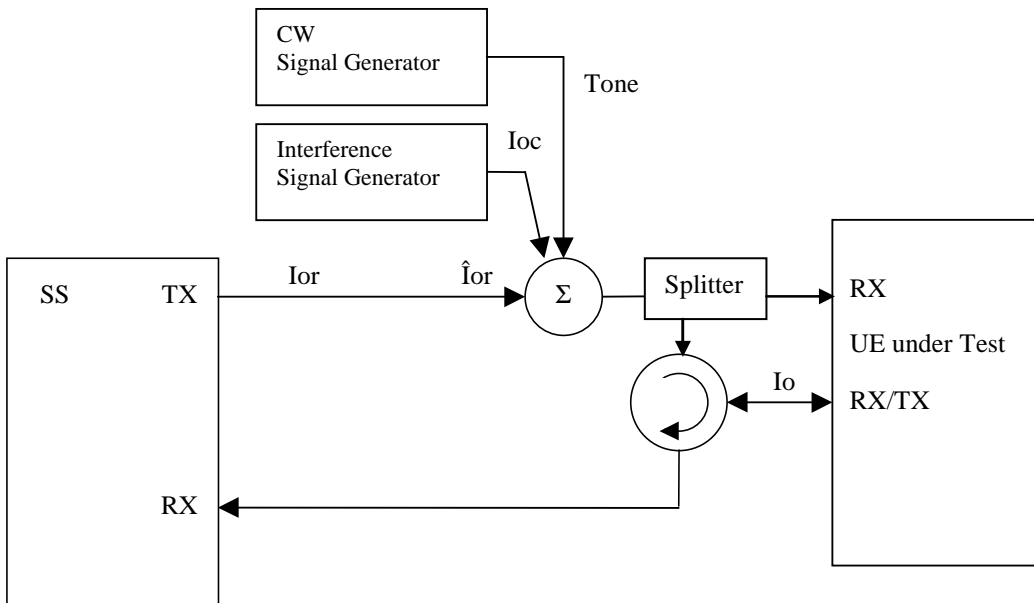

Figure A.6: Connection for Receiver tests with both E-UTRA Interference and additional CW signal

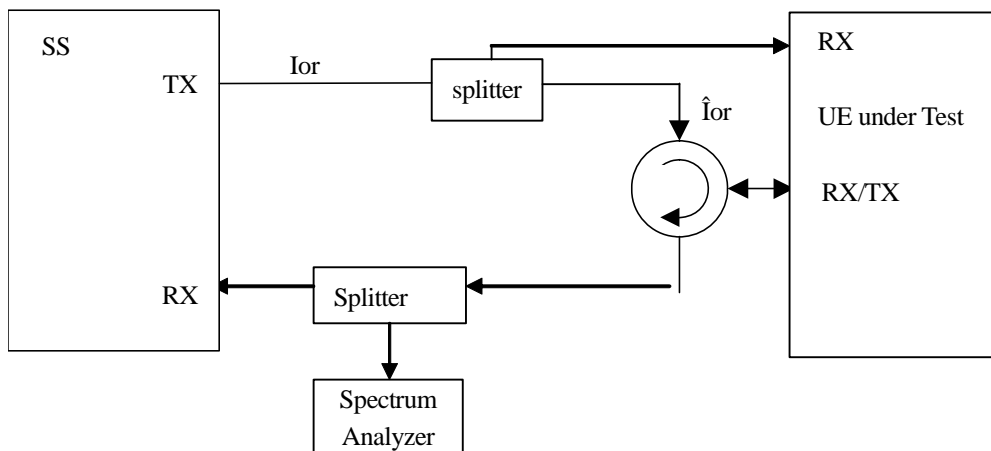

Figure A.7: Connection for TX-tests with additional Spectrum Analyzer

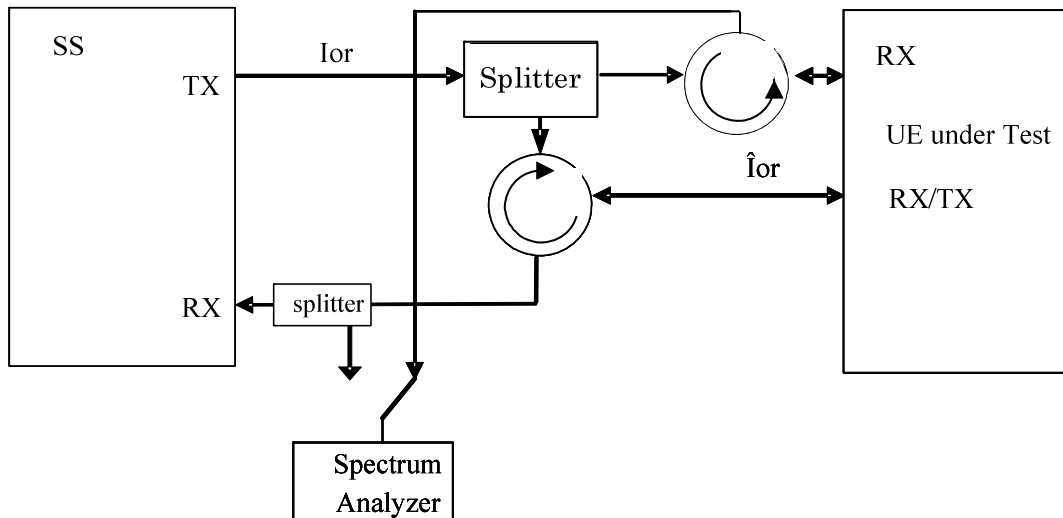

Figure A.8: Connection for RX-tests with additional Spectrum Analyzer

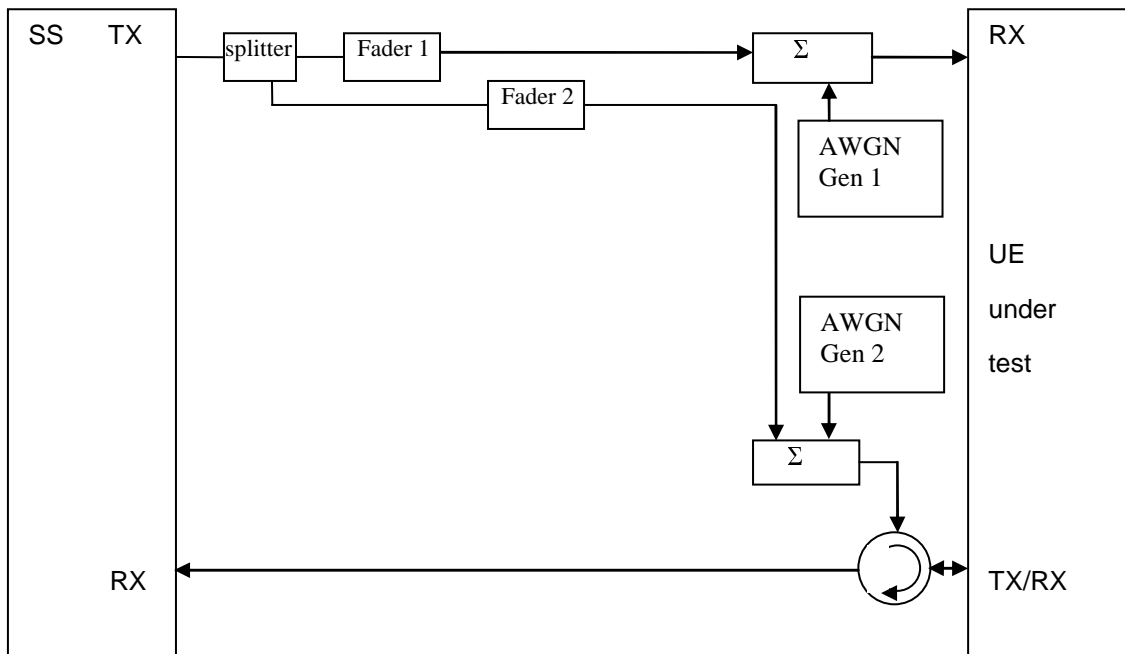

Figure A.9: Connection for RX performance tests with antenna configuration 1x2 (single antenna port)

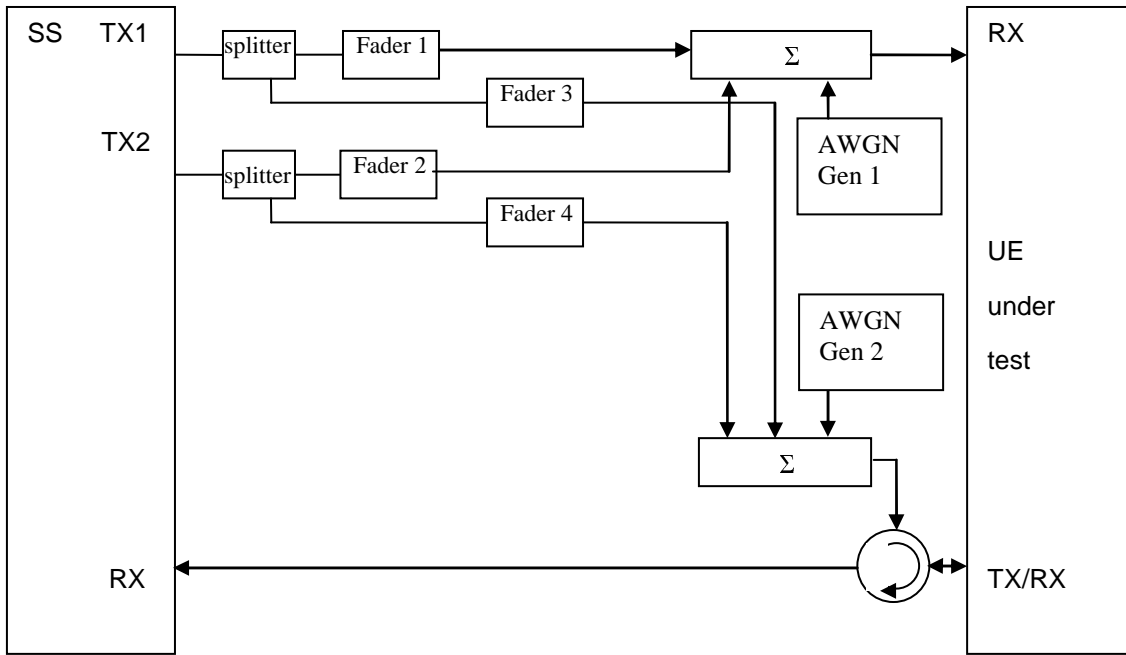

Figure A.10: Connection for RX performance tests with antenna configuration 2x2 (transmit diversity)

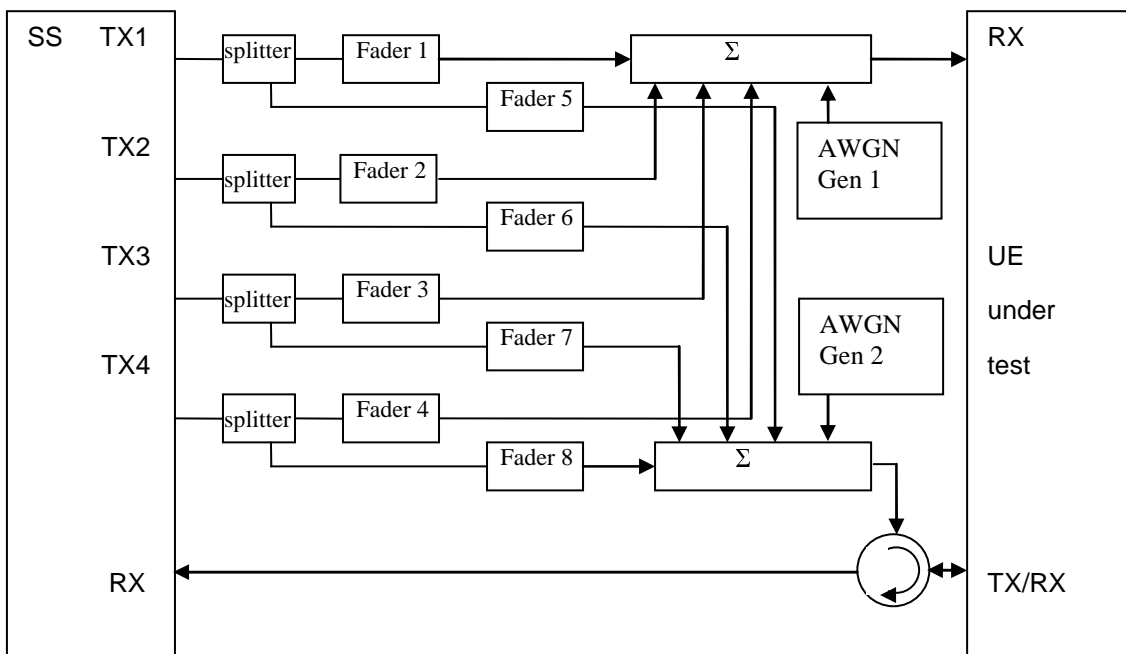

Figure A.11: Connection for RX performance tests with antenna configuration 4x2 (transmit diversity)

Figure A.12: Void

Figure A.13: Void

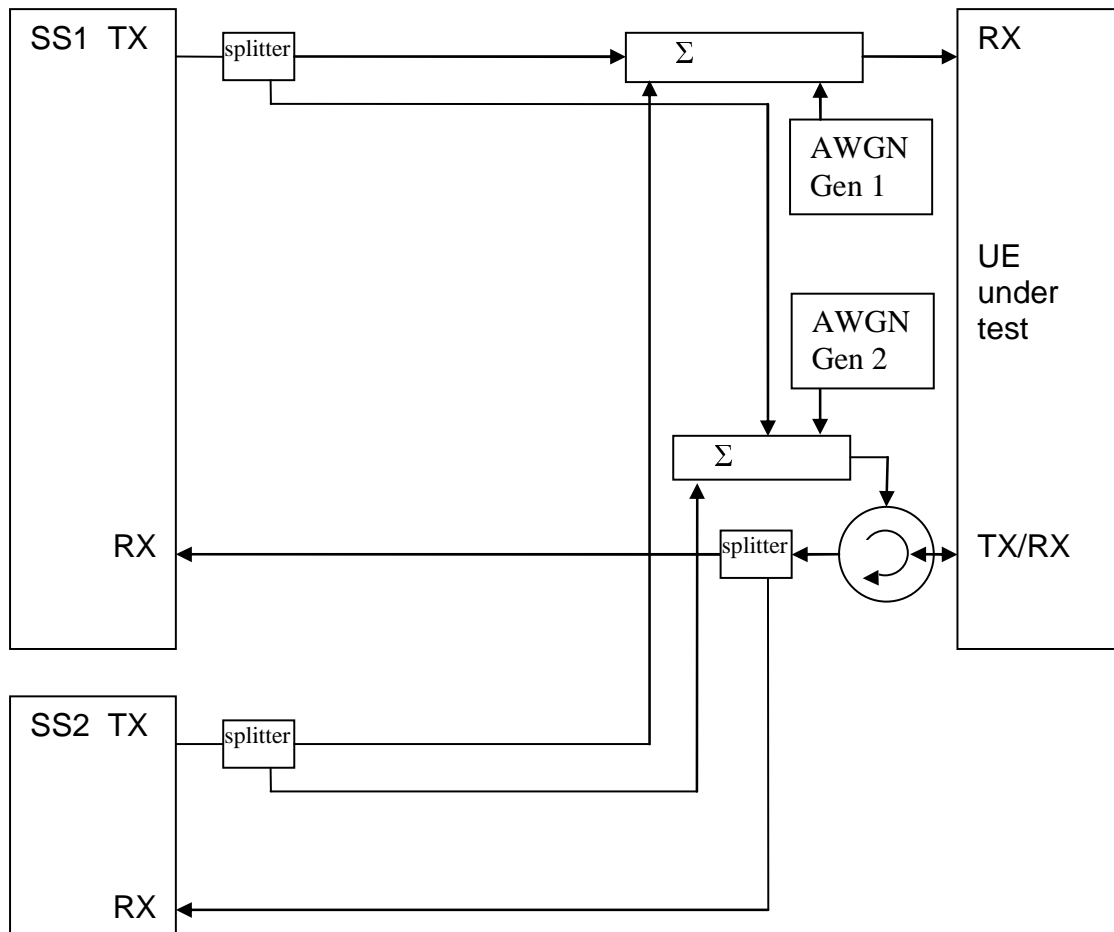

Figure A.14: Connection for 2 cells with static propagation and receive diversity

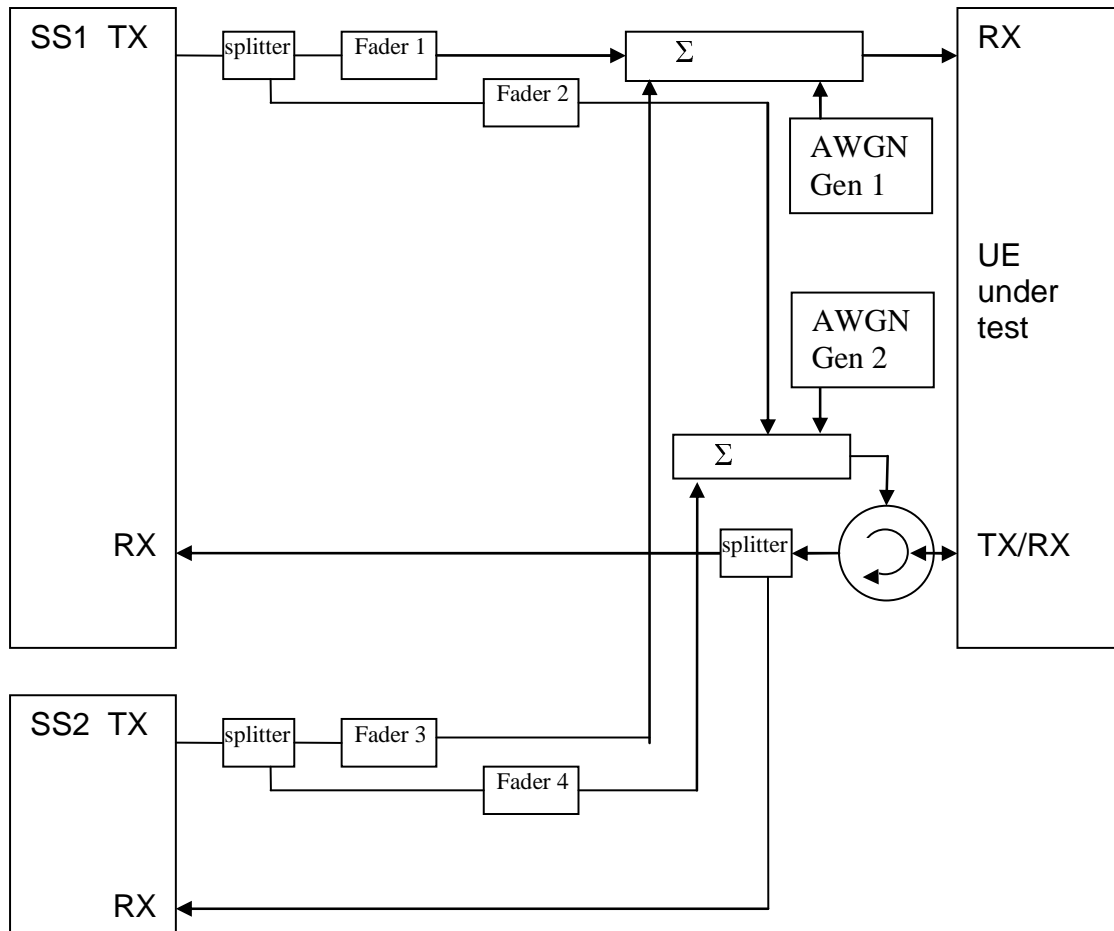

Figure A.15: Connection for 2 cells with multipath fading propagation and receive diversity

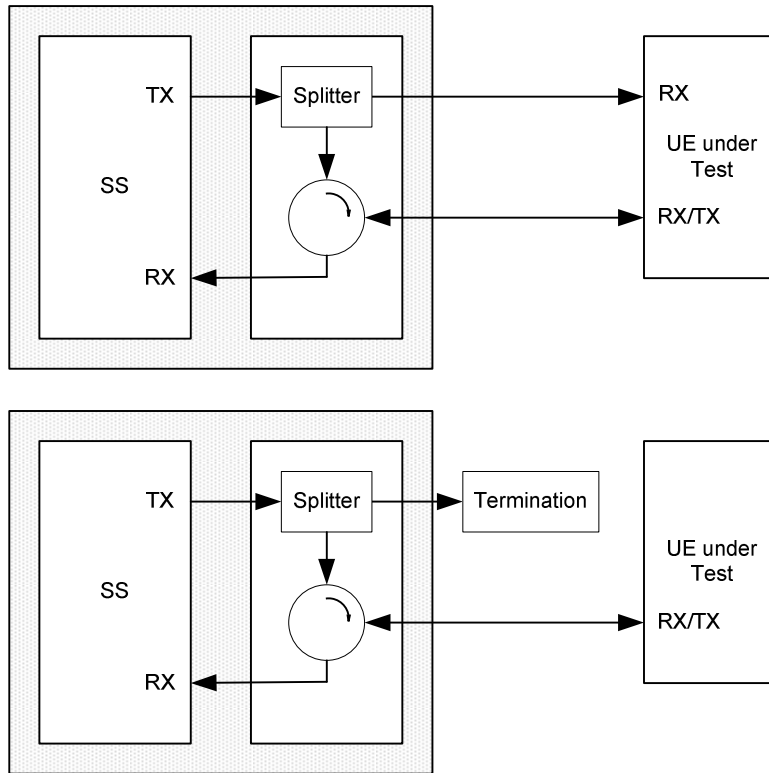

Figure A.16: Connection for single cell Signalling tests

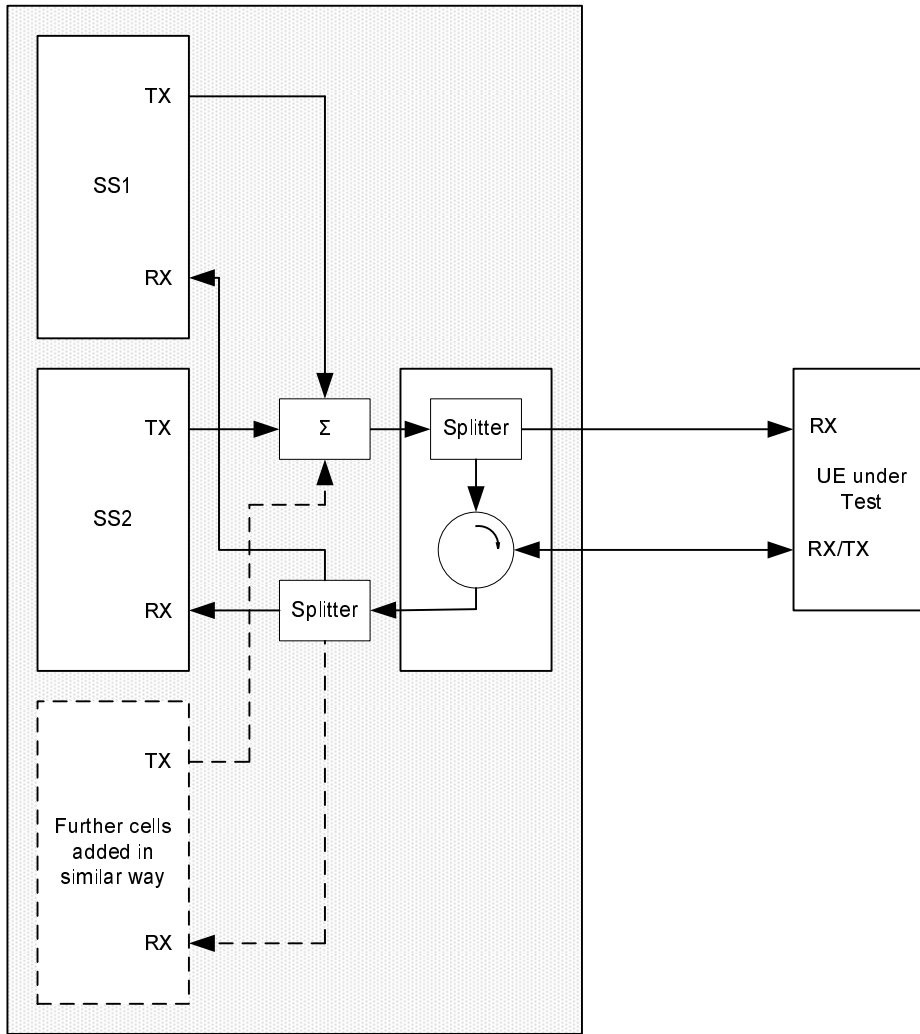

Figure A.17: Connection for multiple cells Signalling tests

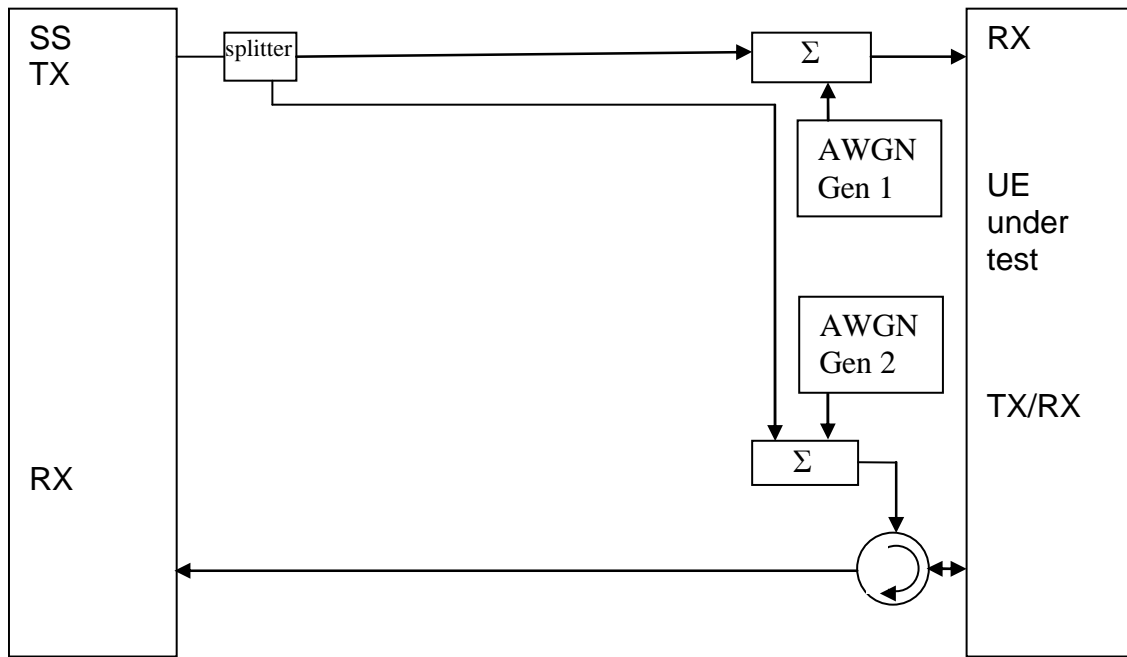

Figure A.18: Connection for 1 cell with antenna configuration 1x2 in static propagation conditions

Annex B (informative): Change history

Meeting-1st-Level	Doc-1st-Level	CR	Rev	Subject	Cat	Version-Current	Version-New	Doc-2nd-Level
RAN5 #37	R5-073107			Skeleton proposed for RAN5#37 Jeju			0.0.1	
RAN5 LTE workshop	R5w080007			Proposed for RAN5 LTE workshop, Sophia Antipolis		0.0.1	0.0.2	
RAN5 #39	R5-081167			Following proposals have been incorporated: R5w080046 R5w080026 R5w080036		0.0.2	0.0.3	
RAN5 #39	R5-081615			Following proposals and many editorial corrections have been incorporated: R5-081564, R5-081561, R5-081248, R5-081530, R5-081126, R5-081443, R5-081382, R5-081200		0.0.3	0.1.0	
RAN5 #39bis	R5-082141			Following proposals and many editorial corrections have been incorporated: R5-082149, "Updates of reference test conditions for TS 36.508" R5-082148, "Addition of E-UTRA TDD Test frequencies for TS36.508" R5-082150, "Default downlink signal channel powers for LTE UE test" R5-082146, "Addition of Cell Environment for multi Cell Configuration" R5-082140, "Proposal of LTE reference system configurations for TS 36.508" R5-082204, "Addition of Cell and UE configuration for TS 36.508" R5-082090, "Update of default RRC message contents" R5-082100, "Proposal on Structure of Default Message Contents for TS 36.508" R5-082091, "Addition of SRB and DRB radio bearer combinations to 36.508" R5-082173, "Connection Diagrams for TX and RX tests"		0.1.0	0.2.0	
RAN5 #40	R5-083399			Following proposals have been incorporated: R5-083800, "Mapping of DL physical channels to physical resources for TS 36.508", NEC R5-083403, "Addition of New Cell Environment for multi Cell Configuration", NTT DOCOMO R5-083529, "Proposal on default system information contents for TS 36.508", NTT DOCOMO R5-083395, "Corrections to generic procedures in TS 36.508", NTT DOCOMO R5-083623, "Update of RRC default message contents and RB combination parameters", Ericsson R5-083622, "Radio Resource Configuration specification for TS 36.508", NEC R5-083397, "Addition of Default NAS message contents in TS 36.508", NTT DOCOMO		0.2.0	1.0.0	
RAN5 #40bis	R5-084102			Following proposals have been incorporated: R5-084101, "Missing corrections to TS 36.508" R5-084110, "Updates of Test frequencies for TS 36.508" R5-084144, "The mapping of DL physical channels to physical resources for TS 36.508" R5-084198, "Update of RA and RB power ratios definition in TS 36.508" R5-084199, "Update of Reference System Configuration in 36.508" R5-084109, "Addition of default RRC message contents to TS 36.508" R5-084202, "Update of RRC Message Contents and RB Configurations in 36.508" R5-084265, "Addition of default RRC message contents for handover" R5-084162, "Connection Diagrams for performance		1.0.0	1.1.0	

Meeting-1st-Level	Doc-1st-Level	CR	Rev	Subject	Cat	Version-Current	Version-New	Doc-2nd-Level
				tests"				
RAN5 #41	R5-085145			Following proposals have been incorporated: R5-085087, "Updates of Test frequencies for TS 36.508" R5-085701, "Cleaning up section 5 in TS 36.508" R5-085252, "Correction to Section 4.3.3.2 of TS 36.508" R5-085315, "Connection Diagrams: delete the editorial note" R5-085454, "Addition of timer tolerances" R5-085566, "Addition of default settings of suitable / non-suitable cells in TS 36.508" R5-085541, "Update to default configurations of simulated cells in TS 36.508" R5-085514, "Update to default configurations of system information blocks in TS 36.508" R5-085472, "Addition of default settings of suitable / non-suitable cells in TS 36.508" R5-085394, "Update of Reference system configurations in 36.508" R5-085457, "Update to generic procedure in TS 36.508" R5-085458, "Addition of new generic procedure to check the UE does not answer to paging" R5-085523, "Update of default RRC message contents" R5-085381, "Addition to default RRC IE contents for measurement configuration" R5-085469, "Update to default NAS message contents in TS 36.508" R5-085451, "Parameter settings for reference RB configurations" R5-085556, "Common test USIM parameters for EPS testing"		1.1.0	2.0.0	
RAN#42	RP-085145			Approval of version 2.0.0 at RAN#42, then updated to v 8.0.0.		2.0.0	8.0.0	
				Editorial corrections.		8.0.0	8.0.1	
RAN5 #41bis	R5-086021	0001	-	Introduction of half cell configurations in eUTRA SS		8.0.1	8.1.0	
RAN5 #41bis	R5-086166	0002	-	Removal of Redundant Environmental Conditions		8.0.1	8.1.0	
RAN5 #41bis	R5-086221	0003	-	CR to 36.508: correction of EARFCN		8.0.1	8.1.0	
RAN5 #41bis	R5-086226	0004	-	Correction to the default system informations in TS 36.508		8.0.1	8.1.0	
RAN5 #41bis	R5-086236	0005	-	Connection diagrams for RRM		8.0.1	8.1.0	
RAN5 #41bis	R5-086346	0006	-	Update of the default message AUTHENTICATION FAILURE		8.0.1	8.1.0	
RAN5 #41bis	R5-086362	0007	-	update of reference configuration systems for CDMA2000 in 36.508		8.0.1	8.1.0	
RAN5 #41bis	R5-086363	0008	-	Updated of common and default parameters for CDMA2000 cells		8.0.1	8.1.0	
RAN5 #41bis	R5-086364	0009	-	Update of SystemInformationBlockType8 in 36.508		8.0.1	8.1.0	
RAN5 #41bis	R5-086369	0010	-	Addition of reference EPS bearer contexts		8.0.1	8.1.0	
RAN5 #41bis	R5-086370	0011	-	Mapping of default DL Physical Channels for TDD in 36.508		8.0.1	8.1.0	
RAN5 #41bis	R5-086400	0012	-	Addition of RS_EPRE powers to default DL signal levels		8.0.1	8.1.0	
RAN5 #42	R5-090084	0013	-	Test procedure to verify that an EPS bearer context is active		8.0.1	8.1.0	
RAN5 #42	R5-090362	0014	-	Correction to the definition of simulated NAS cells in TS 36.508		8.0.1	8.1.0	
RAN5 #42	R5-090464	0015	-	Clean up the test algorithm for authentication		8.0.1	8.1.0	
RAN5 #42	R5-090586	0016	-	Add specific information elements for RRC reconfiguration		8.0.1	8.1.0	
RAN5 #42	R5-090630	0017	-	Introduction of alternative DRX configurations		8.0.1	8.1.0	
RAN5 #42	R5-090681	0018	-	Correction to the default NAS message contents in TS 36.508		8.0.1	8.1.0	
RAN5 #42	R5-090682	0019	-	Correction to the definition of simulated cells in TS 36.508		8.0.1	8.1.0	

Meeting-1st-Level	Doc-1st-Level	CR	Rev	Subject	Cat	Version-Current	Version-New	Doc-2nd-Level
RAN5 #42	R5-090698	0020	-	Update of 4.5 generic procedures in 36.508		8.0.1	8.1.0	
RAN5 #42	R5-090699	0021	-	TDD RTT correction for timer tolerance		8.0.1	8.1.0	
RAN5 #42	R5-090759	0022	-	Correction to the default RRC message contents in TS 36.508		8.0.1	8.1.0	
RAN5 #42	R5-091000	0023	-	Correction to clause 4.3.3.3		8.0.1	8.1.0	
RAN5 #42	R5-091001	0024	-	LTE-RF: Clarification to 36.508 Simulated Cells for RF tests		8.0.1	8.1.0	
RAN5 #43	RP-090447	0025	-	Correction to Cell off power		8.1.0	8.2.0	R5-092086
RAN5 #43	RP-090447	0026	-	LTE Signalling Tests: UE Rx antenna connection		8.1.0	8.2.0	R5-092087
RAN5 #43	RP-090448	0027	-	CR to 36.508 for subclause 4.3.1 channel bandwidth clarification for RF tests (re-submit no changes)		8.1.0	8.2.0	R5-092124
RAN5 #43	RP-090448	0028	-	Text for 4.2.2: Minimum functional requirements		8.1.0	8.2.0	R5-092128
RAN5 #43	RP-090448	0029	-	Annex A: transition from 1 to 2 RX antenna		8.1.0	8.2.0	R5-092132
RAN5 #43	RP-090447	0030	-	Update of SN length in UM RLC default configuration		8.1.0	8.2.0	R5-092202
RAN5 #43	RP-090448	0031	-	TP for simulated UTRA TDD cell parameter		8.1.0	8.2.0	R5-092275
RAN5 #43	RP-090447	0032	-	Correction to specific message contents in setup procedure in TS 36.508		8.1.0	8.2.0	R5-092349
RAN5 #43	RP-090447	0033	-	Correction to the definition of simulated NAS cells in TS 36.508		8.1.0	8.2.0	R5-092352
RAN5 #43	RP-090447	0034	-	CR on 6.7 TDD Timer Tolerance in 36.508		8.1.0	8.2.0	R5-092363
RAN5 #43	RP-090448	0044	-	Update of 4.5.2A in 36.508 (Re-submit not change)		8.1.0	8.2.0	R5-092457
RAN5 #43	RP-090448	0035	-	Default value of q-RxLevMin for RF TCs		8.1.0	8.2.0	R5-092458
RAN5 #43	RP-090598	0045	-	CR to 36.508 Addition of test frequencies for band 18 and band 19		8.1.0	8.2.0	R5-092535
RAN5 #43	RP-090447	0036	-	Update of the default NAS message contents in TS 36.508		8.1.0	8.2.0	R5-092708
RAN5 #43	RP-090447	0037	-	Correction to reference radio bearer configurations		8.1.0	8.2.0	R5-092721
RAN5 #43	RP-090447	0038	-	Definition of default Test Control (TC) messages		8.1.0	8.2.0	R5-092734
RAN5 #43	RP-090448	0039	-	Modification of procedures in section 4.5.2.3 /4.5.2A		8.1.0	8.2.0	R5-092735
RAN5 #43	RP-090447	0040	-	Addition of default physical layer parameters		8.1.0	8.2.0	R5-092736
RAN5 #43	RP-090447	0041	-	Correction to default RRC message contents		8.1.0	8.2.0	R5-092738
RAN5 #43	RP-090447	0042	-	Introduction in 36.508 of a common tracking/routing area update procedure for Idle mode and RRC connection release test cases		8.1.0	8.2.0	R5-092765
RAN5 #43	RP-090447	0043	-	Corrections to default system configurations in TS 36.508		8.1.0	8.2.0	R5-092773
RAN5 #43	RP-090447	0046	-	Max. resources for signalling test cases		8.1.0	8.2.0	R5-092723
-	-	-	-	Editorial corrections and merging of all sections together		8.2.0	8.2.1	-
RAN5 #44	RP-090802	0047	-	Correction to the default value of ul-Bandwidth in TS 36.508	F	8.2.1	8.3.0	R5-094059
RAN5 #44	RP-090802	0048	-	UTRAN SIB scheduling for LTE interRAT test	F	8.2.1	8.3.0	R5-094072
RAN5 #44	RP-090802	0049	-	Correction to the default NAS message contents	F	8.2.1	8.3.0	R5-094141
RAN5 #44	RP-090802	0050	-	TDD fields in default physical layer parameters	F	8.2.1	8.3.0	R5-094279
RAN5 #44	RP-090802	0051	-	Addition of UTRA reference radio bearer parameters and GERAN reference PDP context parameters for E-UTRA Inter-RAT testing	F	8.2.1	8.3.0	R5-094304
RAN5 #44	RP-090801	0052	-	System information scheduling for RF testing	F	8.2.1	8.3.0	R5-094311
RAN5 #44	RP-090801	0053	-	Connection for 1 cell with antenna configuration 1x2 in static propagation conditions	F	8.2.1	8.3.0	R5-094364
RAN5	RP-090801	0054	-	Correction to 4.3.1.2.5 TDD reference test frequencies	F	8.2.1	8.3.0	R5-094373

Meeting-1st-Level	Doc-1st-Level	CR	Rev	Subject	Cat	Version-Current	Version-New	Doc-2nd-Level
#44				for Operating Band 37				
RAN5 #44	RP-090801	0055	-	LTE RF: Physical Layer configurations for RF/RRM testing	F	8.2.1	8.3.0	R5-094421
RAN5 #44	RP-090802	0056	-	Update of SN length in PDCP default configuration	F	8.2.1	8.3.0	R5-094533
RAN5 #44	RP-090802	0057	-	Corrections to default RRC message and IE contents	F	8.2.1	8.3.0	R5-094639
RAN5 #44	RP-090801	0058	-	Update of TDD reference test frequencies for operating band 40	F	8.2.1	8.3.0	R5-094786
RAN5 #44	RP-090810	0059	-	TDD special subframe pattern update	F	8.2.1	8.3.0	R5-094901
RAN5 #44	RP-090802	0060	-	corrections to reference RB configurations	F	8.2.1	8.3.0	R5-095064
RAN5 #44	RP-090802	0061	-	Correction of test procedure 6.4.2.7 in TS 36.508	F	8.2.1	8.3.0	R5-095093
RAN5 #44	RP-090802	0062	-	Adding new elementary files to the default USIM settings	F	8.2.1	8.3.0	R5-095100
RAN5 #44	RP-090802	0063	-	Correction to the Test procedure to check RRC_IDLE state	F	8.2.1	8.3.0	R5-095102
RAN5 #44	RP-090802	0064	-	Introduction of UE mode of operation into NAS default message contents	F	8.2.1	8.3.0	R5-095138
RAN5 #44	RP-090802	0065	-	TDD ACK/NACK feedback mode update	F	8.2.1	8.3.0	R5-095152
RAN5 #44	RP-090802	0066	-	Corrections to default signal levels	F	8.2.1	8.3.0	R5-095206
RAN5 #44	RP-090802	0067	-	Update to default messages in regard to IP address allocation	F	8.2.1	8.3.0	R5-095218

History

Document history		
V8.0.1	January 2009	Publication
V8.1.0	April 2009	Publication
V8.2.1	July 2009	Publication
V8.3.0	October 2009	Publication