

ETSI TS 137 105 V14.0.0 (2017-04)



**Universal Mobile Telecommunications System (UMTS);
LTE;
Active Antenna System (AAS) Base Station (BS)
transmission and reception
(3GPP TS 37.105 version 14.0.0 Release 14)**



Reference

RTS/TSGR-0437105ve00

Keywords

LTE,UMTS

ETSI

650 Route des Lucioles
F-06921 Sophia Antipolis Cedex - FRANCE

Tel.: +33 4 92 94 42 00 Fax: +33 4 93 65 47 16

Siret N° 348 623 562 00017 - NAF 742 C
Association à but non lucratif enregistrée à la
Sous-Préfecture de Grasse (06) N° 7803/88

Important notice

The present document can be downloaded from:

<http://www.etsi.org/standards-search>

The present document may be made available in electronic versions and/or in print. The content of any electronic and/or print versions of the present document shall not be modified without the prior written authorization of ETSI. In case of any existing or perceived difference in contents between such versions and/or in print, the only prevailing document is the print of the Portable Document Format (PDF) version kept on a specific network drive within ETSI Secretariat.

Users of the present document should be aware that the document may be subject to revision or change of status.

Information on the current status of this and other ETSI documents is available at

<https://portal.etsi.org/TB/ETSI/DeliverableStatus.aspx>

If you find errors in the present document, please send your comment to one of the following services:

<https://portal.etsi.org/People/CommitteeSupportStaff.aspx>

Copyright Notification

No part may be reproduced or utilized in any form or by any means, electronic or mechanical, including photocopying and microfilm except as authorized by written permission of ETSI.

The content of the PDF version shall not be modified without the written authorization of ETSI.

The copyright and the foregoing restriction extend to reproduction in all media.

© European Telecommunications Standards Institute 2017.

All rights reserved.

DECT™, PLUGTESTS™, UMTS™ and the ETSI logo are Trade Marks of ETSI registered for the benefit of its Members.

3GPP™ and LTE™ are Trade Marks of ETSI registered for the benefit of its Members and of the 3GPP Organizational Partners.

oneM2M logo is protected for the benefit of its Members

GSM® and the GSM logo are Trade Marks registered and owned by the GSM Association.

Intellectual Property Rights

IPRs essential or potentially essential to the present document may have been declared to ETSI. The information pertaining to these essential IPRs, if any, is publicly available for **ETSI members and non-members**, and can be found in ETSI SR 000 314: *"Intellectual Property Rights (IPRs); Essential, or potentially Essential, IPRs notified to ETSI in respect of ETSI standards"*, which is available from the ETSI Secretariat. Latest updates are available on the ETSI Web server (<https://ipr.etsi.org>).

Pursuant to the ETSI IPR Policy, no investigation, including IPR searches, has been carried out by ETSI. No guarantee can be given as to the existence of other IPRs not referenced in ETSI SR 000 314 (or the updates on the ETSI Web server) which are, or may be, or may become, essential to the present document.

Foreword

This Technical Specification (TS) has been produced by ETSI 3rd Generation Partnership Project (3GPP).

The present document may refer to technical specifications or reports using their 3GPP identities, UMTS identities or GSM identities. These should be interpreted as being references to the corresponding ETSI deliverables.

The cross reference between GSM, UMTS, 3GPP and ETSI identities can be found under <http://webapp.etsi.org/key/queryform.asp>.

Modal verbs terminology

In the present document "**shall**", "**shall not**", "**should**", "**should not**", "**may**", "**need not**", "**will**", "**will not**", "**can**" and "**cannot**" are to be interpreted as described in clause 3.2 of the [ETSI Drafting Rules](#) (Verbal forms for the expression of provisions).

"**must**" and "**must not**" are **NOT** allowed in ETSI deliverables except when used in direct citation.

Contents

Intellectual Property Rights	2
Foreword.....	2
Modal verbs terminology.....	2
Foreword.....	8
1 Scope	9
2 References	9
3 Definitions, symbols and abbreviations	10
3.1 Definitions	10
3.2 Symbols.....	14
3.3 Abbreviations	14
4 General	15
4.1 Relationship between the AAS BS specification and non-AAS BS single RAT & MSR specifications	15
4.2 Relationship between minimum requirements and test requirements	16
4.3 Conducted and radiated requirement reference points	16
4.4 Base station classes for AAS BS	17
4.5 Regional Requirements	17
4.6 Operating Bands and Band Categories	18
4.7 Channel arrangements	19
4.8 Requirements for contiguous and non-contiguous spectrum.....	19
4.9 Requirements for AAS BS capable of operation in multiple operating bands	19
5 Applicability of Requirements	20
5.1 General	20
5.2 Band category 1 (BC1) and band category 2 (BC2).....	20
5.3 Band category 3 (BC3).....	23
6 Conducted transmitter characteristics	24
6.1 General	24
6.2 Base station output power	25
6.2.1 General.....	25
6.2.2 Maximum output power.....	25
6.2.2.1 General	25
6.2.2.2 Minimum requirement for MSR operation	25
6.2.2.2.1 General	25
6.2.2.2.2 Additional requirements (regional).....	25
6.2.2.3 Minimum requirement for single RAT UTRA operation.....	25
6.2.2.4 Minimum requirement for single RAT E-UTRA operation.....	25
6.2.2.4.1 General	25
6.2.2.4.2 Additional requirements (regional).....	26
6.2.3 UTRA FDD primary CPICH power	26
6.2.3.1 General	26
6.2.3.2 Minimum requirement for MSR operation	26
6.2.3.3 Minimum requirement for single RAT UTRA operation.....	26
6.2.3.4 Minimum requirement for single RAT E-UTRA operation.....	26
6.2.4 UTRA TDD primary CCPCH power.....	26
6.2.4.1 General	26
6.2.4.2 Minimum requirement for MSR operation	27
6.2.4.3 Minimum requirement for single RAT UTRA operation.....	27
6.2.4.4 Minimum requirement for single RAT E-UTRA operation.....	27
6.2.5 UTRA FDD additional CPICH power for MIMO mode	27
6.2.5.1 General	27
6.2.5.2 Minimum requirement for MSR operation	28
6.2.5.3 Minimum requirement for single RAT UTRA operation.....	28
6.2.5.4 Minimum requirement for single RAT E-UTRA operation.....	29

6.2.6	E-UTRA DL RS power.....	29
6.2.6.1	General.....	29
6.2.6.2	Minimum requirement for MSR operation.....	29
6.2.6.3	Minimum requirement for single RAT UTRA operation.....	29
6.2.6.4	Minimum requirement for single RAT E-UTRA operation.....	29
6.3	Output power dynamics.....	30
6.3.1	General.....	30
6.3.2	UTRA Inner loop power control in the downlink.....	30
6.3.2.1	General.....	30
6.3.2.2	Minimum requirement for MSR operation.....	30
6.3.2.3	Minimum requirement for single RAT UTRA operation.....	30
6.3.2.4	Minimum requirement for single RAT E-UTRA operation.....	31
6.3.3	Power control dynamic range.....	31
6.3.3.1	General.....	31
6.3.3.2	Minimum requirement for MSR operation.....	31
6.3.3.3	Minimum requirement for single RAT UTRA operation.....	31
6.3.3.4	Minimum requirement for single RAT E-UTRA operation.....	31
6.3.4	Total power dynamic range.....	31
6.3.4.1	General.....	31
6.3.4.2	Minimum requirement for MSR operation.....	32
6.3.4.3	Minimum requirement for single RAT UTRA operation.....	32
6.3.4.4	Minimum requirement for single RAT E-UTRA operation.....	32
6.3.5	IPDL time mask.....	32
6.3.5.1	General.....	32
6.3.5.2	Minimum requirement for MSR operation.....	32
6.3.5.3	Minimum requirement for single RAT UTRA operation.....	32
6.3.5.4	Minimum requirement for single RAT E-UTRA operation.....	32
6.3.6	RE Power control dynamic range.....	32
6.3.6.1	General.....	32
6.3.6.2	Minimum requirement for MSR operation.....	33
6.3.6.3	Minimum requirement for single RAT UTRA operation.....	33
6.3.6.4	Minimum requirement for single RAT E-UTRA operation.....	33
6.4	Transmit ON/OFF power.....	33
6.4.1	General.....	33
6.4.2	Transmitter OFF power.....	33
6.4.2.1	General.....	33
6.4.2.2	Minimum requirement for MSR operation.....	33
6.4.2.3	Minimum requirement for single RAT UTRA operation.....	33
6.4.2.4	Minimum requirement for single RAT E-UTRA operation.....	33
6.4.3	Transmitter transient period.....	34
6.4.3.1	General.....	34
6.4.3.2	Minimum requirement for MSR operation.....	34
6.4.3.3	Minimum requirement for single RAT UTRA operation.....	34
6.4.3.4	Minimum requirement for single RAT E-UTRA operation.....	34
6.5	Transmitted signal quality.....	34
6.5.1	General.....	34
6.5.2	Frequency Error.....	34
6.5.2.1	General.....	34
6.5.2.2	Minimum requirement for MSR operation.....	35
6.5.2.3	Minimum requirement for single RAT UTRA operation.....	35
6.5.2.4	Minimum requirement for single RAT E-UTRA operation.....	35
6.5.3	Time alignment error.....	35
6.5.3.1	General.....	35
6.5.3.2	Minimum requirement for MSR operation.....	36
6.5.3.3	Minimum requirement for single RAT UTRA operation.....	36
6.5.3.4	Minimum requirement for single RAT E-UTRA operation.....	36
6.5.4	Modulation quality.....	36
6.5.4.1	General.....	36
6.5.4.2	Minimum requirement for MSR operation.....	36
6.5.4.3	Minimum requirement for single RAT UTRA operation.....	36
6.5.4.4	Minimum requirement for single RAT E-UTRA operation.....	37
6.5.5	Transmit pulse shape filter.....	37

6.5.5.1	General	37
6.5.5.2	Minimum requirement for MSR operation	37
6.5.5.3	Minimum requirement for single RAT UTRA operation.....	37
6.5.5.4	Minimum requirement for single RAT E-UTRA operation.....	37
6.6	Unwanted Emissions	37
6.6.1	General.....	37
6.6.2	Occupied bandwidth	38
6.6.2.1	General	38
6.6.2.2	Minimum requirement for MSR operation	38
6.6.2.3	Minimum requirement for single RAT UTRA operation.....	38
6.6.2.4	Minimum requirement for single RAT E-UTRA operation.....	38
6.6.3	Adjacent Channel Leakage power Ratio.....	39
6.6.3.1	General	39
6.6.3.2	Minimum requirement for MSR operation	39
6.6.3.3	Minimum requirement for single RAT UTRA operation.....	40
6.6.3.4	Minimum requirement for single RAT E-UTRA operation.....	40
6.6.4	Spectrum emission mask	40
6.6.4.1	General	40
6.6.4.2	Minimum requirement for MSR operation	40
6.6.4.3	Minimum requirement for single RAT UTRA operation.....	40
6.6.4.3.1	General	40
6.6.4.3.2	Basic limits for single RAT UTRA FDD operation	40
6.6.4.3.3	Basic limits for single RAT UTRA TDD 1,28Mcps option operation.....	46
6.6.4.4	Minimum requirement for single RAT E-UTRA operation.....	48
6.6.5	Operating band unwanted emission	48
6.6.5.1	General	48
6.6.5.2	Minimum requirement for MSR operation	48
6.6.5.2.1	General	48
6.6.5.2.2	<i>Basic limits</i> for Band Categories 1 and 3.....	49
6.6.5.2.3	<i>Basic limit</i> for Band Category 2	52
6.6.5.2.4	Additional requirements	57
6.6.5.3	Minimum requirement for single RAT UTRA operation.....	57
6.6.5.4	Minimum requirement for single RAT E-UTRA operation.....	57
6.6.5.4.1	General	57
6.6.5.4.2	Basic limits for Wide Area BS (Category A)	59
6.6.5.4.3	Basic limits for Wide Area BS (Category B)	62
6.6.5.4.3.1	General.....	62
6.6.5.4.3.2	Category B requirements (Option 1).....	62
6.6.5.4.3.3	Category B (Option 2)	66
6.6.5.4.4	Basic limits for Local Area BS (Category A and B)	68
6.6.5.4.5	Basic limits for Medium Range BS (Category A and B).....	69
6.6.5.4.7	Additional requirements	71
6.6.6	Spurious emission.....	71
6.6.6.1	General	71
6.6.6.2	Minimum requirement for MSR operation	72
6.6.6.3	Minimum requirement for single RAT UTRA operation.....	72
6.6.6.4	Minimum requirement for single RAT E-UTRA operation.....	73
6.7	Transmitter intermodulation.....	73
6.7.1	General.....	73
6.7.2	Minimum requirement for MSR operation	73
6.7.2.1	General co-location minimum requirement.....	73
6.7.2.2	Additional co-location minimum requirement (BC1 and BC2)	74
6.7.2.3	Additional co-location minimum requirement (BC3)	75
6.7.2.4	Additional co-location minimum requirements.....	75
6.7.2.5	Intra-system minimum requirement	75
6.7.3	Minimum requirement for single RAT UTRA operation	76
6.7.3.1	General co-location minimum requirement for FDD UTRA	76
6.7.3.2	General co-location minimum requirement for 1,28 Mcps TDD UTRA	76
6.7.3.3	Intra-system minimum requirement	77
6.7.4	Minimum requirement for single RAT E-UTRA operation.....	77
6.7.4.1	General co-location minimum requirement.....	77
6.7.4.2	Additional requirement for Band 41	78

6.7.4.3	Intra-system minimum requirement	78
7	Conducted receiver characteristics	79
7.1	General	79
7.2	Reference sensitivity level.....	80
7.2.1	General.....	80
7.2.2	Minimum requirement for MSR operation	80
7.2.3	Minimum requirement for single RAT UTRA operation	80
7.2.4	Minimum requirement for single RAT E-UTRA operation.....	80
7.3	Dynamic range	80
7.3.1	General.....	80
7.3.2	Minimum requirement for MSR operation	80
7.3.3	Minimum requirement for single RAT UTRA operation	81
7.3.4	Minimum requirement for single RAT E-UTRA operation.....	81
7.4	Adjacent channel selectivity, general blocking, and narrowband blocking.....	81
7.4.1	General.....	81
7.4.2	Minimum requirement for MSR operation	81
7.4.2.1	General minimum requirement	81
7.4.2.2	General narrowband blocking minimum requirement	83
7.4.2.3	Additional BC3 blocking minimum requirement.....	83
7.4.3	Minimum requirement for single RAT UTRA operation	84
7.4.4	Minimum requirement for single RAT E-UTRA operation.....	84
7.5	Blocking	84
7.5.1	General.....	84
7.5.2	Minimum requirement for MSR operation	84
7.5.2.1	General minimum requirement	84
7.5.2.2	Co-location minimum requirement	85
7.5.3	Minimum requirement for single RAT UTRA operation	88
7.5.3.1	General minimum requirement	88
7.5.3.2	Co-location minimum requirement	88
7.5.4	Minimum requirement for single RAT E-UTRA operation.....	89
7.5.4.1	General minimum requirement	89
7.5.4.2	Co-location minimum requirement	89
7.6	Receiver spurious emissions.....	89
7.6.1	General.....	89
7.6.2	Minimum requirement for MSR operation	89
7.6.2.1	General minimum requirement	89
7.6.3	Minimum requirement for single RAT UTRA operation	90
7.6.4	Minimum requirement for single RAT E-UTRA operation.....	91
7.7	Receiver intermodulation	91
7.7.1	General.....	91
7.7.2	Minimum requirement for MSR operation	91
7.7.2.1	General intermodulation minimum requirement.....	91
7.7.2.2	General narrowband intermodulation minimum requirement	92
7.7.3	Minimum requirement for single RAT UTRA operation	94
7.7.4	Minimum requirement for single RAT E- UTRA operation.....	94
7.8	In-channel selectivity	94
7.8.1	General.....	94
7.8.2	Minimum requirement for MSR operation	94
7.8.3	Minimum requirement for single RAT UTRA operation	94
7.8.4	Minimum requirement for single RAT E-UTRA operation.....	94
8	Performance requirements.....	95
8.1	General	95
8.1.1	UTRA operation	95
8.1.2	E-UTRA operation.....	96
8.2	Minimum requirements for MSR operation	96
8.3	Minimum requirements for UTRA operation.....	96
8.4	Minimum requirements for E-UTRA operation	97
9	Radiated transmitter characteristics.....	97
9.1	General	97
9.2	Radiated transmit power.....	97

9.2.1	General.....	97
9.2.2	Minimum requirement for MSR operation	97
9.2.3	Minimum requirement for single RAT UTRA operation	98
9.2.4	Minimum requirement for single RAT E-UTRA operation.....	98
10	Radiated receiver characteristics	98
10.1	General	98
10.2	OTA sensitivity	98
10.2.1	General.....	98
10.2.2	Minimum requirement for MSR operation	99
10.2.3	Minimum requirement for single RAT UTRA operation	99
10.2.4	Minimum requirement for single RAT E-UTRA operation.....	99
Annex A (normative):	Environmental requirements for the BS equipment	100
Annex B (informative):	Change history	101
History		104

Foreword

This Technical Specification has been produced by the 3rd Generation Partnership Project (3GPP) Technical Specification Group (TSG) Radio Access Networks (RAN).

The contents of the present document are subject to continuing work within the TSG and may change following formal TSG approval. Should the TSG modify the contents of the present document, it will be re-released by the TSG with an identifying change of release date and an increase in version number as follows:

Version x.y.z

where:

- x the first digit:
 - 1 presented to TSG for information;
 - 2 presented to TSG for approval;
 - 3 or greater indicates TSG approved document under change control.
- y the second digit is incremented for all changes of substance, i.e. technical enhancements, corrections, updates, etc.
- z the third digit is incremented when editorial only changes have been incorporated in the document.

1 Scope

The present document establishes the RF characteristics, the RF minimum requirements and minimum performance requirements for E-UTRA AAS Base Station (BS), the FDD mode of UTRA AAS Base Station (BS), the 1,28 Mcps TDD mode of UTRA AAS Base Station (BS) in single RAT and any MSR AAS Base Station (BS) implementation of these RATs.

The present document does not establish minimum RF characteristics or minimum performance requirements for Narrow-Band Internet of Things (NB-IoT) in band, NB-IoT guard band, or standalone NB-IoT operation, for AAS BS in *single RAT E-UTRA operation* or in *MSR operation* using E-UTRA.

2 References

The following documents contain provisions which, through reference in this text, constitute provisions of the present document.

- References are either specific (identified by date of publication, edition number, version number, etc.) or non-specific.
- For a specific reference, subsequent revisions do not apply.
- For a non-specific reference, the latest version applies. In the case of a reference to a 3GPP document (including a GSM document), a non-specific reference implicitly refers to the latest version of that document *in the same Release as the present document*.

- [1] 3GPP TR 21.905: "Vocabulary for 3GPP Specifications".
- [2] 3GPP TS 25.104: "Base Station (BS) radio transmission and reception (FDD)".
- [3] 3GPP TS 25.105: "Base Station (BS) radio transmission and reception (TDD)".
- [4] 3GPP TS 36.104: "Evolved Universal Terrestrial Radio Access (E-UTRA); Base Station (BS) radio transmission and reception".
- [5] 3GPP TS 37.104: "E-UTRA, UTRA and GSM/EDGE Multi-Standard Radio (MSR) Base Station (BS) radio transmission and reception".
- [6] 3GPP TS 25.104 (V13.3.0): "Base Station (BS) radio transmission and reception (FDD) (Release 13)".
- [7] 3GPP TS 25.105 (V13.1.0): "Base Station (BS) radio transmission and reception (TDD) (Release 13)".
- [8] 3GPP TS 36.104 (V13.6.0): "Evolved Universal Terrestrial Radio Access (E-UTRA); Base Station (BS) radio transmission and reception (Release 13)".
- [9] 3GPP TS 37.104 (V13.4.0): "E-UTRA, UTRA and GSM/EDGE Multi-Standard Radio (MSR) Base Station (BS) radio transmission and reception (Release 13)".
- [10] 3GPP TS 25.142 (V13.1.0): "Base Station (BS) conformance testing (TDD) (Release 13)".
- [11] Recommendation ITU-R M.1545: "Measurement uncertainty as it applies to test limits for the terrestrial component of International Mobile Telecommunications-2000".
- [12] 3GPP TS 25.942: "Radio Frequency (RF) system scenarios".
- [13] 3GPP TS 37.145 (all parts): "Active Antenna System (AAS) Base Station (BS) conformance testing".
- [14] Recommendation ITU-R SM.329-10: "Unwanted emissions in the spurious domain".
- [15] "Title 47 of the Code of Federal Regulations (CFR)", Federal Communications Commission.

- [16] 3GPP TS 25.331 (V13.4.0): "Radio Resource Control (RRC); Protocol specification (Release 13)".
- [17] Recommendation ITU-R SM.328-11: "Spectra and bandwidth of emissions".
- [18] FCC publication number 662911: "Emissions Testing of Transmitters with Multiple Outputs in the Same Band".
- [19] 3GPP TS 37.141: "E-UTRA, UTRA and GSM/EDGE; Multi-Standard Radio (MSR) Base Station (BS) conformance testing".
- [20] 3GPP TS 36.141: "Evolved Universal Terrestrial Radio Access (E-UTRA); Base Station (BS) conformance testing".
- [21] IEC 60721-3-3: "Classification of environmental conditions - Part 3-3: Classification of groups of environmental parameters and their severities - Stationary use at weather protected locations".
- [22] IEC 60721-3-4: "Classification of environmental conditions - Part 3: Classification of groups of environmental parameters and their severities - Section 4: Stationary use at non-weather protected locations".
- [23] ETSI EN 300 019-1-3: "Environmental Engineering (EE); Environmental conditions and environmental tests for telecommunications equipment; Part 1-3: Classification of environmental conditions; Stationary use at weather protected locations".
- [24] ETSI EN 300 019-1-4: "Environmental Engineering (EE); Environmental conditions and environmental tests for telecommunications equipment; Part 1-4: Classification of environmental conditions; Stationary use at non-weather protected locations".
- [25] CEPT ECC Decision (13)03, "The harmonised use of the frequency band 1452-1492 MHz for Mobile/Fixed Communications Networks Supplemental Downlink (MFCN SDL)".

3 Definitions, symbols and abbreviations

3.1 Definitions

For the purposes of the present document, the terms and definitions given in 3GPP TR 21.905 [1] and the following apply. A term defined in the present document takes precedence over the definition of the same term, if any, in 3GPP TR 21.905 [1].

NOTE: Multi-word definitions are treated as linguistic expressions and printed in italic font throughout this requirement specification. Linguistic expressions may not be split and are to be printed in their entirety.

AAS BS receiver: composite receiver function of an AAS BS receiving in an *uplink operating band*

active antenna system base station: base station system which combines an antenna array with a transceiver unit array and a *radio distribution network*

active transmitter unit: transmitter unit which is ON, and has the ability to send modulated data streams that are parallel and distinct to those sent from other transmitter units to one or more *TAB connectors* at the *transceiver array boundary*

band category: group of *operating bands* for which the same MSR scenarios apply

Base Station RF Bandwidth: bandwidth in which a base station transmits and/or receives single or multiple carrier(s) and/or RATs simultaneously within a supported *operating band*

NOTE: In single carrier operation, the *Base Station RF Bandwidth* is equal to the *channel bandwidth*.

Base Station RF Bandwidth edge: frequency of one of the edges of the *Base Station RF Bandwidth*

basic limit: emissions limit taken from the non-AAS BS specifications that is converted into a per *TAB connector TX min cell group* AAS BS emissions limit, or into a per *TAB connector RX min cell group* AAS BS emissions limit by scaling, depending on the context

beam: main lobe of a radiation pattern from an AAS BS

NOTE: For certain AAS BS antenna array, there may be more than one beam.

beam centre direction: direction equal to the geometric centre of the half-power EIRP contour of the beam

beam direction pair: data set consisting of the *beam centre direction* and the related *beam peak direction*

beam peak direction: direction where the maximum EIRP is supposed to be found

beamwidth: angles describing the major and minor axes of an ellipsoid closest fit to an essentially elliptic half-power EIRP contour of the beam

carrier: modulated waveform conveying the E-UTRA or UTRA physical channels

carrier aggregation: aggregation of two or more E-UTRA component carriers in order to support wider *transmission bandwidths*

channel bandwidth: RF bandwidth supporting a single RF carrier with the *transmission bandwidth* configured in the uplink or downlink of a cell

NOTE 1: The *channel bandwidth* is measured in MHz and is used as a reference for transmitter and receiver RF requirements.

NOTE 2: For UTRA FDD, the *channel bandwidth* is the nominal channel spacing specified in 3GPP TS 25.104 [2]. For UTRA TDD 1,28 Mcps, the *channel bandwidth* is the nominal channel spacing specified in 3GPP TS 25.105 [3].

NOTE 3: For E-UTRA, the *channel bandwidths* are specified in 3GPP TS 36.104 [4]. Standalone NB-IoT channel bandwidths specified in 3GPP TS 36.104 [4] are not applicable to AAS BS.

code domain power: part of the mean power which correlates with a particular (OVSF) code channel in a UTRA signal

NOTE: The sum of all powers in the code domain equals the mean power in a bandwidth of $(1+\alpha)$ times the chip rate of the radio access mode.

demodulation branch: single input of the AAS BS *receiver* to the demodulation algorithms.

NOTE 1: For UTRA *non-AAS BS* a *demodulation branch* is referred to as a receive diversity branch or an UL MIMO branch. For E-UTRA *non-AAS BS* a *demodulation branch* is referred to as an RX antenna in the performance requirement tables.

NOTE 2: The term "RX antenna" in chapter 8 (i.e. Performance requirements) of the E-UTRA specification 3GPP TS 36.104 [4] does not refer to physical receiver antennas.

downlink operating band: part of the (FDD) *operating band* designated for downlink transmission

EIRP accuracy directions set: *beam peak directions* for which the EIRP accuracy requirement is intended to be met.

NOTE: The *beam peak directions* are related to a corresponding contiguous range or discrete list of *beam centre directions* by the *beam direction pairs* included in the set.

equivalent isotropic radiated power: equivalent power radiated from an isotropic directivity device producing the same field intensity at a point of observation as the field intensity radiated in the direction of the same point of observation by the discussed device

NOTE: Isotropic directivity is equal in all directions (i.e. 0 dBi).

equivalent isotropic sensitivity: sensitivity for an isotropic directivity device equivalent to the sensitivity of the discussed device exposed to an incoming wave from a defined AoA

NOTE 1: The sensitivity is the minimum received power level at which a RAT specific requirement is met.

NOTE 2: Isotropic directivity is equal in all directions (i.e. 0 dBi).

inter-band gap: frequency gap between two supported consecutive operating bands

Inter RF Bandwidth gap: frequency gap between two consecutive *Base Station RF Bandwidths* that are placed within two supported *operating bands*

maximum carrier output power per TAB connector: mean power level measured on a particular carrier at the *TAB connector(s)*, during the *transmitter ON period* in a specified reference condition

maximum throughput: maximum achievable throughput for a reference measurement channel

MSR operation: operation of AAS BS declared to be MSR in particular *operating band(s)*

multi-band requirements: requirements applying per one single *operating band* with exclusion bands or other multi-band provisions as defined for each requirement

multi-band TAB connector: *TAB connector* supporting operation in multiple *operating bands* through common active electronic component(s)

NOTE: For common TX and RX *TAB connectors*, the definition applies where common active electronic components are in the transmit path and/or in the receive path.

NB-IoT in-band operation: NB-IoT is operating in-band when it utilizes the resource block(s) within a normal E-UTRA carrier

NB-IoT guard band operation: NB-IoT is operating in guard band when it utilizes the unused resource block(s) within a E-UTRA carrier's guard-band

NB-IoT standalone operation: NB-IoT is operating standalone when it utilizes its own spectrum, for example the spectrum currently being used by GERAN systems as a replacement of one or more GSM carriers, as well as scattered spectrum for potential IoT deployment

non-AAS BS: BS conforming to one of the specifications in 3GPP TS 25.104 [2], 3GPP TS 25.105 [3], 3GPP TS 36.104 [4] or 3GPP TS 37.104 [5]

NOTE: For AAS BS in *single RAT E-UTRA operation* or in *MSR operation* using E-UTRA, the NB-IoT operation (including in-band, guard band and standalone operation) is excluded from the consideration in the performance comparison among AAS BS and *non-AAS BS* in this specification.

non-contiguous spectrum: spectrum consisting of two or more *sub-blocks* separated by *sub-block gap(s)*

OTA sensitivity directions declaration: set of manufacturer declarations comprising at least one set of declared minimum EIS values (with related RAT and *channel bandwidth*), and related directions over which the EIS applies

NOTE: All the directions apply to all the EIS values in an OSDD.

output power at a TAB connector: mean power delivered to a load with resistance equal to the nominal load impedance of the *TAB connector*

polarization match: condition that exists when a plane wave, incident upon an antenna from a given direction, has a polarization that is the same as the receiving polarization of the antenna in that direction

Radio Bandwidth: frequency difference between the upper edge of the highest used carrier and the lower edge of the lowest used carrier

radio distribution network: linear passive network which distributes the RF power generated by the transceiver unit array to the antenna array, and/or distributes the radio signals collected by the antenna array to the transceiver unit array

NOTE: In the case when the active transceiver units are physically integrated with the array elements of the antenna array, the *radio distribution network* is a one-to-one mapping.

rated beam EIRP: EIRP that is declared as being achieved in the *beam peak direction* associated with a particular *beam direction pair*

rated carrier output power per TAB connector: mean power level associated with a particular carrier the manufacturer has declared to be available at the *TAB connector*, during the *transmitter ON period* in a specified reference condition

rated total output power per TAB connector: mean power level associated with a particular *operating band* the manufacturer has declared to be available at the *TAB connector*, during the *transmitter ON period* in a specified reference condition

receive period: time during which the AAS BS is receiving data sub-frames (or UpPTS in case of E-UTRA frame Type2) on a (TDD) carrier

receiver target: AoA in which reception is performed by AAS BS

receiver target redirection range: union of all the *sensitivity RoAoA* achievable through redirecting the *receiver target* related to particular OSDD

receiver target reference direction: direction inside the *OTA sensitivity directions declaration* declared by the manufacturer for conformance testing. For an OSDD without *receiver target redirection range*, this is a direction inside the *sensitivity RoAoA*

reference beam direction pair: declared *beam direction pair*, including reference *beam centre direction* and reference *beam peak direction* where the reference *beam peak direction* is the direction for the intended maximum EIRP within the *EIRP accuracy directions set* compliance

sensitivity RoAoA: RoAoA within the *OTA sensitivity directions declaration*, within which the declared EIS(s) of an OSDD is intended to be achieved at any instance of time for a specific AAS BS direction setting

single band requirements: requirements applying per one single *operating band* without exclusion bands or other multi-band provisions

single band TAB connector: *TAB connector* supporting operation either in a single *operating band* only, or in multiple *operating bands* but without any common active electronic component(s)

single RAT E-UTRA operation: operation of AAS BS declared to be single RAT E-UTRA in the *operating band*

NOTE: *Single RAT E-UTRA operation* does not cover in-band NB-IoT, nor guardband NB-IoT operation.

single RAT UTRA operation: operation of AAS BS declared to be single RAT UTRA in the *operating band*

sub-block: one contiguous allocated block of spectrum for use by the same Base Station

NOTE: There may be multiple instances of *sub-blocks* within a Base Station RF Bandwidth.

sub-block gap: frequency gap between two consecutive *sub-blocks* within a Base Station RF Bandwidth, where the RF requirements in the gap are based on co-existence for un-coordinated operation

TAB connector: *transceiver array boundary* connector

TAB connector RX min cell group: *operating band* specific declared group of *TAB connectors* to which RX requirements are applied.

NOTE: Within this definition, the group corresponds to the group of *TAB connectors* which are responsible for receiving a cell when the AAS BS setting corresponding to the declared minimum number of cells with transmission on all *TAB connectors* supporting an *operating band*, but its existence is not limited to that condition.

TAB connector TX min cell group: *operating band* specific declared group of *TAB connectors* to which TX requirements are applied.

NOTE: Within this definition, the group corresponds to the group of *TAB connectors* which are responsible for transmitting a cell when the AAS BS setting corresponding to the declared minimum number of cells with transmission on all *TAB connectors* supporting an *operating band*, but its existence is not limited to that condition.

throughput: number of payload bits successfully received per second for a reference measurement channel in a specified reference condition

transceiver array boundary: conducted interface between the transceiver unit array and the composite antenna

transmission bandwidth: RF bandwidth of an instantaneous E-UTRA transmission from a UE or BS, measured in resource Block units

transmitter OFF period: time period during which the transmitter is scheduled not to transmit

NOTE: For AAS BS, this definition applies per *TAB connector* and *operating band*.

transmitter ON period: time period during which the transmitter is transmitting data and/or reference symbols

NOTE: For AAS BS, this definition applies per *TAB connector* and *operating band*.

transmitter transient period: time period during which the transmitter unit belonging to the transceiver unit array is changing from the OFF period to the ON period or vice versa

NOTE: For AAS BS, this definition applies per *TAB connector* and *operating band*.

uplink operating band: part of the (FDD) *operating band* designated for uplink transmission

3.2 Symbols

For the purposes of the present document, the following symbols apply:

N_{cells}	The declared number corresponding to the minimum number of cells that can be transmitted by an AAS BS in a particular band with transmission on all <i>TAB connectors</i> supporting the operating band.
$N_{\text{RXU,active}}$	The number of active receiver units. The same as the number of <i>demodulation branches</i> to which compliance is declared for chapter 8 performance requirements.
$N_{\text{RXU,counted}}$	The number of active receiver units that are taken into account for unwanted emission scaling, as calculated in subclause 7.1.
$N_{\text{RXU,countedpercell}}$	The number of active receiver units that are taken into account for unwanted emissions scaling per cell, as calculated in subclause 7.6. The number is defined in subclause 7.1.
$N_{\text{TXU, active}}$	The number of <i>active transmitter units</i> .
$N_{\text{TXU,counted}}$	The number of <i>active transmitter units</i> , as calculated in subclause 6.1, that are taken into account or conducted TX power limit in subclause 6.2, and for unwanted emissions scaling.
$N_{\text{TXU,countedpercell}}$	The number of <i>active transmitter units</i> that are taken into account for emissions scaling per cell, as calculated in subclause 6.6. The number is defined in subclause 6.1.
$P_{\text{max,c,cell}}$	The <i>maximum carrier output power per TAB connector TX min cell group</i>
$P_{\text{max,c,TABC}}$	The <i>maximum carrier output power per TAB connector</i>
$P_{\text{Rated,c,TABC}}$	The <i>rated carrier output power per TAB connector</i>
$P_{\text{Rated,c,sys}}$	The sum of $P_{\text{Rated,c,TABC}}$ for all <i>TAB connectors</i> for a single carrier
$P_{\text{Rated,t,group}}$	The sum of $P_{\text{Rated,t,TABC}}$ for all <i>TAB connectors</i> belonging to a specified group
$P_{\text{Rated,t,TABC}}$	The <i>rated total output power per TAB connector</i>
P_{REFSENS}	Reference Sensitivity power level

3.3 Abbreviations

For the purposes of the present document, the abbreviations given in 3GPP TR 21.905 [1] and the following apply. An abbreviation defined in the present document takes precedence over the definition of the same abbreviation, if any, in 3GPP TR 21.905 [1].

AAS BS	Active Antenna System Base Station
ACLR	Adjacent Channel Leakage power Ratio
ACS	Adjacent Channel Selectivity
AoA	Angle of Arrival
BC	Band Category
BER	Bit Error Rate
CACLR	Cumulative ACLR
CW	Continuous Wave (unmodulated signal)
D-CPICH	Demodulation Common Pilot Channel
EIRP	Equivalent Isotropic Radiated Power
EIS	Equivalent Isotropic Sensitivity
FCC	Federal Communications Commission

FDD	Frequency Division Duplex
FRC	Fixed Reference Channel
HARQ	Hybrid Automatic Repeat Request
HS-DSCH	High Speed Downlink Shared Channel
ITU	International Telecommunication Union
ITU-R	Radio communication Sector of the ITU
MIMO	Multiple Inputs Multiple Outputs
MSR	Multi-Standard Radio
NB-IoT	Narrowband – Internet of Things
OSDD	OTA Sensitivity Directions Declaration
OTA	Over The Air
OVSF	Orthogonal variable spreading factor
PCCPCH	Primary Common Control Physical CHannel
RAT	Radio Access Technology
RB	Resource Block (for E-UTRA)
RDN	Radio Distribution Network
RE	Resource Element
RF	Radio Frequency
RoAoA	Range of Angles of Arrival
TAB	Transceiver Array Boundary
TDD	Time Division Duplex

4 General

4.1 Relationship between the AAS BS specification and non-AAS BS single RAT & MSR specifications

An AAS BS is distinguished from a *non-AAS BS* by including a dedicated antenna system in its design.

The transceiver to antenna RF interface of the AAS BS (referred to as the *transceiver array boundary*) comprises one or several *TAB connectors*. There is no general one-to-one relationship between *non-AAS BS* antenna connectors and AAS BS *TAB connectors*, but it can be expected the number of *TAB connectors* in AAS BS will be greater than or equal to the number of *non-AAS BS* antenna connectors for respective base stations with corresponding functionality.

For the conducted requirements, the AAS BS requirements are formulated in such a way that the impact of what they are meant to regulate is expected to be "equivalent" to the corresponding *non-AAS BS* requirements; i.e. the outside world sees the same level of emissions, power levels, or can expect the same demodulation performance at the UE from the AAS BS as it would from a *non-AAS BS* with equivalent functionality. All *non-AAS BS* RF requirements (referenced to the *non-AAS BS* antenna connector) have been adapted to AAS BS conducted requirements. Many requirements are also direct references to the *non-AAS BS* RF specifications 3GPP TS 25.104 [2], 3GPP TS 25.105 [3], 3GPP TS 36.104 [4] and 3GPP TS 37.104 [5].

NOTE 1: Applying *non-AAS BS* antenna connector requirements directly to individual *TAB connectors* renders certain AAS BS requirements excessively strict from a system perspective.

NOTE 2: Both specific references and non-specific references occur.

In addition, a new set of requirements referred to as radiated requirements or OTA requirements is introduced in subclauses 9 and 10 for transmitter and receiver, respectively. These requirements have no corresponding *non-AAS BS* requirements.

In this specification, the term "requirements for *single RAT operation*" refers to requirements that are derived from the 3GPP TS 25.104 [2], 3GPP TS 25.105 [3], or 3GPP TS 36.104 [4] specifications baseline, whilst "requirements for *MSR operation*" refers to requirements derived from the 3GPP TS 37.104 [5] specification baseline.

NB-IoT in-band, NB-IoT guard band, or standalone NB-IoT operation is not supported by AAS BS. When referring to standalone E-UTRA requirements for *single RAT operation* in 3GPP TS 36.104 [4] or to E-UTRA requirements for *MSR operation* in 3GPP TS 37.104 [5], any requirements specified in those specifications for E-UTRA with NB-IoT (in-band or guard band) or for standalone NB-IoT, shall not be considered for the AAS BS. Unless otherwise stated, the

exclusion of the NB-IoT requirements in this specification applies to all operation modes (i.e. *in-band NB-IoT operation*, *guard band NB-IoT operation* and *standalone NB-IoT operation*).

Band 46 operation is not supported by AAS BS. When referring to standalone E-UTRA requirements for *single RAT operation* in 3GPP TS 36.104 [4] or to E-UTRA requirements for *MSR operation* in 3GPP TS 37.104 [5], any requirements specified in those specifications for Band 46 operation shall not be considered for the AAS BS with E-UTRA.

4.2 Relationship between minimum requirements and test requirements

Conformance to the present specification is demonstrated by fulfilling the test requirements specified in the conformance specification 3GPP TS 37.145 [13], part 1 and part 2.

The minimum requirements given in this specification make no allowance for measurement uncertainty. The test specification 3GPP TS 37.145 [13] defines test tolerances. These test tolerances are individually calculated for each test. The test tolerances are used to relax the minimum requirements in this specification to create test requirements. For some requirements, including regulatory requirements, the test tolerance is set to zero.

The measurement results returned by the test system are compared - without any modification - against the test requirements as defined by the shared risk principle. The shared risk principle is defined in Recommendation ITU-R M.1545 [11].

4.3 Conducted and radiated requirement reference points

AAS BS requirements are defined for two points of reference, signified by radiated requirements and conducted requirements.

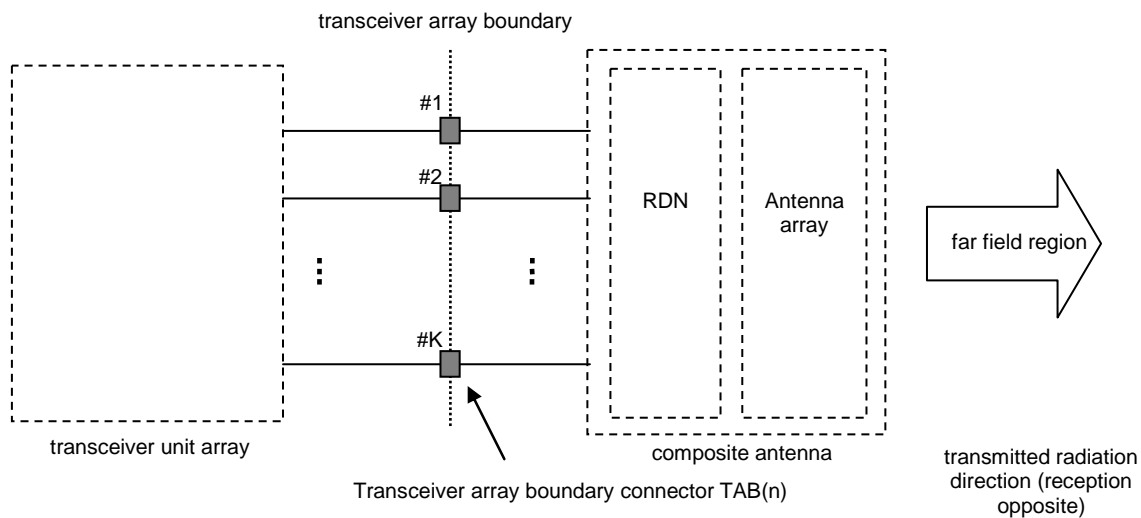

Figure 4.3-1: Radiated and conducted points of reference of AAS BS

Radiated characteristics are defined over the air (OTA) with a point of reference in the far field (Fraunhofer) region. Radiated requirements are also referred to as OTA requirements. The (spatial) directions in which the OTA requirements apply are detailed for each requirement.

Conducted characteristics are defined at individual or groups of *TAB connectors* at the *transceiver array boundary*, which is the conducted interface between the transceiver unit array and the composite antenna.

The transceiver unit array is part of the composite transceiver functionality generating modulated transmit signal structures and performing receiver combining and demodulation.

The transceiver unit array contains an implementation specific number of transmitter units and an implementation specific number of receiver units. Transmitter units and receiver units may be combined into transceiver units. The transmitter/receiver units have the ability to transmit/receive parallel independent modulated symbol streams.

The composite antenna contains a radio distribution network (RDN) and an antenna array. The RDN is a linear passive network which distributes the RF power generated by the transceiver unit array to the antenna array, and/or distributes the radio signals collected by the antenna array to the transceiver unit array, in an implementation specific way.

How a conducted requirement is applied to the *transceiver array boundary* is detailed in the respective requirement sub-clause.

4.4 Base station classes for AAS BS

The requirements in the present document apply to AAS BS of Wide Area BS, Medium Range BS and Local Area BS classes unless otherwise stated.

Wide Area BS are characterized by requirements derived from Macro Cell scenarios. For AAS BS of Wide Area BS class, the minimum coupling loss between any *TAB connector* and the UE is 70 dB.

NOTE: Whenever WA BS is referred in this specification, the NB-IoT Wide Area BS and related requirements as defined in 3GPP TS 36.104 [4], are not applicable for AAS BS.

Medium Range BS are characterized by requirements derived from Micro Cell scenarios. For AAS BS of Medium Range BS class, the minimum coupling loss between any *TAB connector* and the UE is 53 dB.

Local Area BS are characterized by requirements derived from Pico Cell scenarios. For AAS BS of Local Area BS class, the minimum coupling loss between any *TAB connector* and the UE is 45 dB.

4.5 Regional Requirements

Some requirements in the present document may only apply in certain regions either as optional requirements, or as mandatory requirements set by local and regional regulation. It is normally not stated in the 3GPP specifications under what exact circumstances the regional requirements apply, since this is defined by local or regional regulation.

Table 4.5-1 lists all requirements in the present specification that may be applied differently in different regions. *Non-AAS BS* requirements are applicable as defined in the present document. In many cases, such requirements include regional requirements that are implicitly referenced from the present specification, and listed in the specification for the specifications concerned 3GPP TS 25.104 [2], 3GPP TS 25.105 [3], 3GPP TS 36.104 [4] and 3GPP TS 37.104 [5].

Table 4.5-1: List of regional requirements

Clause number	Requirement	Comments
4.6	Operating bands and Band Categories	Some bands may be applied regionally.
6.2.2.4.2	Base station output power	These requirements apply in Japan for an E-UTRA BS operating in band 34 and Band 41.
6.6.2	Occupied bandwidth	The requirement may be applied regionally. There may also be regional requirements to declare the Occupied bandwidth according to the definition.
6.6.4	Spectrum emission mask	The mask specified may be mandatory in certain regions. In other regions this mask may not be applied. Additional spectrum protection requirements may apply regionally.
6.6.5	Operating band unwanted emissions	The BS may have to comply with the applicable emission limits established by FCC Title 47 [15], when deployed in regions where those limits are applied and under the conditions declared by the manufacturer.
6.6.5	Operating band unwanted emissions	The requirements for unsynchronized TDD co-existence may apply regionally.
6.6.5	Operating band unwanted emissions	The requirements for protection of DTT may apply regionally.
6.6.5	Operating band unwanted emissions	Regional requirement as defined in 3GPP TS 37.104, subclause 6.6.2.4.4 [9] may be applied for the protection of systems operating in frequency bands adjacent to band 1 as defined in 3GPP TS 37.104, subclause 4.5, [9] in geographic areas in which both an adjacent band service and UTRA and/or E-UTRA are deployed.
6.6.5	Operating band unwanted emissions	Additional requirements for band 41 may apply in certain regions as additional operating band unwanted emission limits.
6.6.5	Operating band unwanted emissions	Additional band 32 unwanted emissions requirements may apply in certain regions
6.6.6	Spurious emissions	Category A limits are mandatory for regions where Category A limits for spurious emissions, as defined in Recommendation ITU-R SM.329 [14] apply. Category B limits are mandatory for regions where Category B limits for spurious emissions, as defined in Recommendation ITU-R SM.329 [14] apply.
6.6.6	Spurious emissions	Additional spurious emissions requirements may be applied for the protection of system operating in frequency ranges other than the AAS BS operating band as described in 3GPP TS 37.104 [9] subclause 6.6.1.3 (NOTE).
6.6.6	Spurious emissions	In addition to 3GPP requirements, the BS may have to comply with the applicable emission limits established by FCC Title 47 [15], when deployed in regions where those limits are applied, and under the conditions declared by the manufacturer.
6.6.6	Spurious emissions	Co-location spurious emissions requirements may be applied for the protection of other BS receivers when an MSR BS operating in another frequency band is co-located with an AAS BS.
6.7	Transmitter intermodulation	Additional requirements may apply in certain regions.
7.5	Blocking	Co-location blocking requirements may be applied for the protection of the BS receiver when a BS operating in another frequency band is co-located with an AAS BS.
NOTE:	AAS BS does not support Band 46 operation, but additional spurious emissions requirements for Band 46 as described in 3GPP TS 37.104 [9] subclause 6.6.1.3, are still applicable for AAS BS for protection of Band 46 operation.	

4.6 Operating Bands and Band Categories

The operating bands and *band categories* for AAS BS are the same as for *non-AAS BS*, as described in 3GPP TS 37.104 [5].

NOTE 1: AAS BS does not support GSM, but BC2 is still applicable for protection of and against GSM operation in BC2 operating bands.

NOTE 2: AAS BS does not support Band 46 (and all its sub-bands defined in 3GPP TS 36.104 [8], subclause 5.5) operation, but Band 46 requirements are still applicable for AAS BS for protection of and against Band 46 operation.

4.7 Channel arrangements

The channel arrangements for AAS BS are the same as those for UTRA *non-AAS BS* and E-UTRA *non-AAS BS* as described in 3GPP TS 37.104 [5].

NOTE: Requirements for nominal carrier spacing of 19.8 MHz and 20.1 MHz for carriers in Band 46 as specified in 36.104 [8] subclause 5.7.1, are not applicable for AAS BS.

4.8 Requirements for contiguous and non-contiguous spectrum

A spectrum allocation where an AAS BS operates can be either contiguous or non-contiguous. Unless otherwise stated, the requirements in the present specification apply for AAS BS configured for both *contiguous spectrum* operation and *non-contiguous spectrum* operation.

For AAS BS operation in *non-contiguous spectrum*, some requirements apply both at the Base Station RF Bandwidth edges and inside the *sub-block gaps*. For each such requirement, it is stated how the limits apply relative to the Base Station RF Bandwidth edges and the *sub-block* edges respectively.

4.9 Requirements for AAS BS capable of operation in multiple operating bands

For AAS BS capable of operation in multiple operating bands, the RF requirements in clause 6, 7, 9, and 10 apply separately to each supported operating band unless otherwise stated.

An AAS BS may be capable of supporting operation in multiple operating bands with one of the following implementations of *TAB connectors* in the *transceiver array boundary*:

- All *TAB connectors* are *single band TAB connectors*.
- Different sets of *single band TAB connectors* support different operating bands, but each *TAB connector* supports only operation in one single operating band.
- Sets of *single band TAB connectors* support operation in multiple operating bands with some *single band TAB connectors* supporting more than one operating band.
- All *TAB connectors* are *multiband TAB connectors*.
- A combination of single band sets and multi-band sets of *TAB connectors* provides support of the AAS BS capability of operation in multiple operating bands.

Unless otherwise stated all requirements specified for an operating band apply only to the set of *TAB connectors* supporting that operating band.

In certain requirements it is explicitly stated that specific additions or exclusions to the requirement apply at *multi-band TAB connectors* as detailed in the requirement subclause.

In the case of an operating band being supported only by *single band TAB connectors* in a *TAB connector TX min cell group* or a *TAB connector RX min cell group*, *single band requirements* apply to that set of *TAB connectors*.

NOTE: Each supported operating band needs to be operated separately during conformance testing on *single band TAB connectors*.

In the case of an operating band being supported only by *multi-band TAB connectors* supporting the same operating band combination in a *TAB connector TX min cell group* or a *TAB connector RX min cell group*, *multi-band requirements* apply to that set of *TAB connectors*.

The case of an operating band being supported by both *multi-band TAB connectors* and *single band TAB connectors* in a *TAB connector TX min cell group* or a *TAB connector RX min cell group* is not covered by the present release of this specification.

The case of an operating band being supported by *multi-band TAB connectors* which are not all supporting the same operating band combination in a *TAB connector TX min cell group* or a *TAB connector RX min cell group* is not covered by the present release of this specification.

For *multi-band TAB connectors* supporting the bands for TDD, the RF requirements in the present specification assume no simultaneous uplink and downlink occur between the bands.

The RF requirements for *multi-band TAB connectors* supporting bands for both FDD and TDD are not covered by the present release of this specification.

5 Applicability of Requirements

5.1 General

The applicability of requirements is related to the band categories described in 3GPP TS 37.104 [5]. This clause captures the requirement clauses' applicability for the respective band categories depending on the operating band specific BS RAT/MSR capability. For each individual band, the manufacturer declares whether the AAS BS conforms to MSR or single RAT requirements.

In the present specification, requirements for *MSR operation* and for *single RAT operation* are defined. If the AAS BS is declared to be single RAT in an operating band, the respective requirements for *single RAT operation* (derived from 3GPP TS 25.104 [2], 3GPP TS 25.105 [3] or 3GPP TS 36.104 [4]) apply in that operating band. If the AAS BS is declared to be MSR (operating one or more RATs) in the operating band, the requirements for *MSR operation* (derived from 3GPP TS 35.104 [5]) apply to that operating band. Where requirements for *MSR operation* comprise RAT specific requirements, these apply only when the AAS BS is operating the RAT in the operating band.

NOTE: An AAS BS declared MSR in an operating band and operating only one RAT is differentiated from an AAS BS declared single RAT in the operating band by the fact that requirements are derived from 3GPP TS 37.104 [5] rather than from the single RAT specifications 3GPP TS 25.104 [2], 3GPP TS 25.105 [3] or 3GPP TS 36.104 [4].

5.2 Band category 1 (BC1) and band category 2 (BC2)

The RF requirements listed in table 5.2-1 apply to AAS BS for each supported operating band belonging to BC1 and BC2. Requirements apply according to the RAT/MSR capability of the AAS BS in the operating band, as listed in the heading of the table. Some requirements listed in the table may not be mandatory or they may apply only regionally. This is further specified in the subclause treating each requirement and in table 4.5-1.

NOTE: Bands in BC1 and BC2 categories are also used for NB-IoT operation. NB-IoT is not applicable for AAS BS.

For operation in multiple operating bands, the applicability of the requirements in table 5.2-1 is determined based on the manufacturer declared AAS BS RAT and single RAT/MSR conformance for each operating band. The applicability of *multi-band requirements* respective *single band requirements* is defined in clause 4.9 and in each referred clause in the table but it cannot be determined by the table itself.

Table 5.2-1: Applicability of requirements for AAS BS operation in BC1 and BC2

RF requirement	AAS BS is MSR capable in the band	AAS BS is MSR capable and operating UTRA only in the band	AAS BS is MSR capable and operating E-UTRA only in the band	AAS BS is single-RAT UTRA FDD in the band	AAS BS is single-RAT E-UTRA FDD in the band
Base station output power	6.2.1 6.2.2.1 6.2.2.2 6.2.3.1 6.2.3.2 6.2.5.1 6.2.5.2 6.2.6.1 6.2.6.2	6.2.1 6.2.2.1 6.2.2.2 6.2.3.1 6.2.3.2 6.2.5.1 6.2.5.2	6.2.1 6.2.2.1 6.2.2.2 6.2.6.1 6.2.6.2	6.2.1 6.2.2.1 6.2.2.3 6.2.3.1 6.2.3.3 6.2.5.1 6.2.5.3	6.2.1 6.2.2.1 6.2.2.4 6.2.6.1 6.2.6.4
Output power dynamics	6.3.1 6.3.2.1 6.3.2.2 6.3.3.1 6.3.3.2 6.3.4.1 6.3.4.2 6.3.5.1 6.3.5.2 6.3.6.1 6.3.6.2	6.3.1 6.3.2.1 6.3.2.2 6.3.3.1 6.3.3.2 6.3.4.1 6.3.4.2 6.3.5.1 6.3.5.2	6.3.1 6.3.4.1 6.3.4.2 6.3.6.1 6.3.6.2	6.3.1 6.3.2.1 6.3.2.3 6.3.3.1 6.3.3.3 6.3.4.1 6.3.4.3 6.3.5.1 6.3.5.3	6.3.1 6.3.4.1 6.3.4.4 6.3.6.1 6.3.6.4
Transmit ON/OFF power	-	-	-	-	-
Transmitted signal quality	6.5.1				
Frequency error	6.5.2.1 6.5.2.2	6.5.2.1 6.5.2.2	6.5.2.1 6.5.2.2	6.5.2.1 6.5.2.3	6.5.2.1 6.5.2.4
Time alignment error	6.5.3.1 6.5.3.2	6.5.3.1 6.5.3.2	6.5.3.1 6.5.3.2	6.5.3.1 6.5.3.3	6.5.3.1 6.5.3.4
Modulation quality	6.5.4.1 6.5.4.2	6.5.4.1 6.5.4.2	6.5.4.1 6.5.4.2	6.5.4.1 6.5.4.3	6.5.4.1 6.5.4.4
Transmit pulse shape filter	6.5.5.1 6.5.5.2	6.5.5.1 6.5.5.2	-	6.5.5.1 6.5.5.3	-
Unwanted emissions	6.6.1				
Occupied bandwidth	6.6.2.1 6.6.2.2	6.6.2.1 6.6.2.2	6.6.2.1 6.6.2.2	6.6.2.1 6.6.2.3	6.6.2.1 6.6.2.4
ACLR (and Cumulative ACLR)	6.6.3.1 6.6.3.2	6.6.3.1 6.6.3.2	6.6.3.1 6.6.3.2	6.6.3.1 6.6.3.3	6.6.3.1 6.6.3.4
Spectrum emission mask	-	-	-	6.6.4.1 6.6.4.3	-
Operating band unwanted emissions	6.6.5.1 6.6.5.2	6.6.5.1 6.6.5.2	6.6.5.1 6.6.5.2	-	6.6.5.1 6.6.5.4
Transmitter spurious emissions	6.6.6.1 6.6.6.2	6.6.6.1 6.6.6.2	6.6.6.1 6.6.6.2	6.6.6.1 6.6.6.3	6.6.6.1 6.6.6.4
Transmitter intermodulation	6.7.1 6.7.2	6.7.1 6.7.2	6.7.1 6.7.2	6.7.1 6.7.3	6.7.1 6.7.4
Reference sensitivity level	7.2.1 7.2.2	7.2.1 7.2.2	7.2.1 7.2.2	7.2.1 7.2.3	7.2.1 7.2.4
Dynamic range	7.3.1 7.3.2	7.3.1 7.3.2	7.3.1 7.3.2	7.3.1 7.3.3	7.3.1 7.3.4
Adjacent channel selectivity and narrowband blocking	7.4.1 7.4.2	7.4.1 7.4.2	7.4.1 7.4.2	7.4.1 7.4.3	7.4.1 7.4.4
Blocking	7.5.1 7.5.2	7.5.1 7.5.2	7.5.1 7.5.2	7.5.1 7.5.3	7.5.1 7.5.4
Receiver spurious emissions	7.6.1 7.6.2	7.6.1 7.6.2	7.6.1 7.6.2	7.6.1 7.6.3	7.6.1 7.6.4
Receiver intermodulation	7.7.1 7.7.2	7.7.1 7.7.2	7.7.1 7.7.2	7.7.1 7.7.3	7.7.1 7.7.4
In-channel selectivity	7.8.1 7.8.2	-	7.8.1 7.8.2	-	7.8.1 7.8.4
Performance requirements	TBD	TBD	TBD	TBD	TBD
Radiated transmit power	9.2.1 9.2.2	9.2.1 9.2.2	9.2.1 9.2.2	9.2.1 9.2.3	9.2.1 9.2.4
OTA sensitivity	10.2.1 10.2.2	10.2.1 10.2.2	10.2.1 10.2.2	10.2.1 10.2.3	10.2.1 10.2.4

RF requirement	AAS BS is MSR capable in the band	AAS BS is MSR capable and operating UTRA only in the band	AAS BS is MSR capable and operating E-UTRA only in the band	AAS BS is single-RAT UTRA FDD in the band	AAS BS is single-RAT E-UTRA FDD in the band
NOTE: For some requirements, the requirement is defined by reference to the respective <i>non-AAS BS</i> . These requirements cannot be identified from this table.					

5.3 Band category 3 (BC3)

The RF requirements listed in table 5.3-1 apply to AAS BS for each supported operating band belonging to BC3. Requirements apply according to the RAT/MSR capability of the AAS BS in the operating band, as listed in the heading of the table. Some requirements listed in the table may not be mandatory or they may apply only regionally. This is further specified in the clause of each requirement and in table 4.5-1.

For operation in multiple operating bands, the applicability of the requirements in table 5.3-1 is determined based on the manufacturer declared AAS BS RAT and single RAT/MSR conformance for each operating band. The applicability of *multi-band requirements* respective *single band requirements* is defined in clause 4.9 and in each referred clause in the table but it cannot be determined by the table itself.

Table 5.3-1: Applicability of requirements for AAS BS operation in BC3

RF requirement	AAS BS is MSR capable in the band	AAS BS is MSR capable and operating UTRA only in the band	AAS BS is MSR capable and operating E-UTRA only in the band	AAS BS is single-RAT UTRA TDD in the band	AAS BS is single-RAT E-UTRA TDD in the band
Base station output power	6.2.1 6.2.2.1 6.2.2.2 6.2.4.1 6.2.4.2 6.2.6.1 6.2.6.2	6.2.1 6.2.2.1 6.2.2.2 6.2.4.1 6.2.4.2	6.2.1 6.2.2.1 6.2.2.2 6.2.6.1 6.2.6.2	6.2.1 6.2.2.1 6.2.2.3 6.2.4.1 6.2.4.3	6.2.1 6.2.2.1 6.2.2.4 6.2.6.1 6.2.6.4
Output power dynamics	6.3.2.1 6.3.2.2 6.3.3.1 6.3.3.2 6.3.4.1 6.3.4.2 6.3.6.1 6.3.6.2	6.3.2.1 6.3.2.2 6.3.3.1 6.3.3.2	6.3.4.1 6.3.4.2 6.3.6.1 6.3.6.2	6.3.2.1 6.3.2.3 6.3.3.1 6.3.3.3	6.3.4.1 6.3.4.4 6.3.6.1 6.3.6.4
Transmit ON/OFF power	6.4	6.4	6.4	6.4	6.4
Transmitted signal quality	6.5.1				
Frequency error	6.5.2.1 6.5.2.2	6.5.2.1 6.5.2.2	6.5.2.1 6.5.2.2	6.5.2.1 6.5.2.3	6.5.2.1 6.5.2.4
Time alignment error	6.5.3.1 6.5.3.2	6.5.3.1 6.5.3.2	6.5.3.1 6.5.3.2	6.5.3.1 6.5.3.3	6.5.3.1 6.5.3.4
Modulation quality	6.5.4.1 6.5.4.2	6.5.4.1 6.5.4.2	6.5.4.1 6.5.4.2	6.5.4.1 6.5.4.3	6.5.4.1 6.5.4.4
Transmit pulse shape filter	6.5.5.1 6.5.5.2	6.5.5.1 6.5.5.2	-	6.5.5.1 6.5.5.3	-
Unwanted emissions	6.6.1				
Occupied bandwidth	6.6.2.1 6.6.2.2	6.6.2.1 6.6.2.2	6.6.2.1 6.6.2.2	6.6.2.1 6.6.2.3	6.6.2.1 6.6.2.4
ACLR (and Cumulative ACLR)	6.6.3.1 6.6.3.2	6.6.3.1 6.6.3.2	6.6.3.1 6.6.3.2	6.6.3.1 6.6.3.3	6.6.3.1 6.6.3.4
Spectrum emission mask	-	-	-	6.6.4.1 6.6.4.3	-
Operating band unwanted emissions	6.6.5.1 6.6.5.2	6.6.5.1 6.6.5.2	6.6.5.1 6.6.5.2	-	6.6.5.1 6.6.5.4
Transmitter spurious emissions	6.6.6.1 6.6.6.2	6.6.6.1 6.6.6.2	6.6.6.1 6.6.6.2	6.6.6.1 6.6.6.3	6.6.6.1 6.6.6.4

RF requirement	AAS BS is MSR capable in the band	AAS BS is MSR capable and operating UTRA only in the band	AAS BS is MSR capable and operating E-UTRA only in the band	AAS BS is single-RAT UTRA TDD in the band	AAS BS is single-RAT E-UTRA TDD in the band
Transmitter intermodulation	6.7.1 6.7.2	6.7.1 6.7.2	6.7.1 6.7.2	6.7.1 6.7.3	6.7.1 6.7.4
Reference sensitivity level	7.2.1 7.2.2	7.2.1 7.2.2	7.2.1 7.2.2	7.2.1 7.2.3	7.2.1 7.2.4
Dynamic range	7.3.1 7.3.2	7.3.1 7.3.2	7.3.1 7.3.2	7.3.1 7.3.2	7.3.1 7.3.2
Adjacent channel selectivity and narrowband blocking	7.4.1 7.4.2	7.4.1 7.4.2	7.4.1 7.4.2	7.4.1 7.4.3	7.4.1 7.4.4
Blocking	7.5.1 7.5.2	7.5.1 7.5.2	7.5.1 7.5.2	7.5.1 7.5.3	7.5.1 7.5.4
Receiver spurious emissions	7.6.1 7.6.2	7.6.1 7.6.2	7.6.1 7.6.2	7.6.1 7.6.3	7.6.1 7.6.4
Receiver intermodulation	7.7.1 7.7.2	7.7.1 7.7.2	7.7.1 7.7.2	7.7.1 7.7.3	7.7.1 7.7.4
In-channel selectivity	7.8.1 7.8.2	-	7.8.1 7.8.2	-	7.8.1 7.8.4
Performance requirements	TBD	TBD	TBD	TBD	TBD
Radiated transmit power	9.2.1 9.2.2	9.2.1 9.2.2	9.2.1 9.2.2	9.2.1 9.2.3	9.2.1 9.2.4
OTA sensitivity	10.2.1 10.2.2	10.2.1 10.2.2	10.2.1 10.2.2	10.2.1 10.2.3	10.2.1 10.2.4
NOTE: For some requirements, the requirement is defined by reference to the respective <i>non-AAS BS</i> . These requirements cannot be identified from this table.					

6 Conducted transmitter characteristics

6.1 General

Unless otherwise stated, the transmitter characteristics are specified with a full complement of transceiver units for the configuration in normal operating conditions.

The manufacturer shall declare the minimum number of supported geographical cells (i.e. geographical areas). The minimum number of supported geographical cells (N_{cells}) relates to the AAS BS setting with the minimum amount of cell splitting supported with transmission on all *TAB connectors* supporting the operating band. The manufacturer shall also declare *TAB connector TX min cell groups* (as defined in clause 3). Every *TAB connector* supporting transmission in an operating band shall map to one *TAB connector TX min cell group* supporting the same. The mapping of *TAB connectors* to cells is implementation dependent.

The number of *active transmitter units* that are considered when calculating the emissions limit ($N_{\text{TXU, counted}}$) for an AAS BS is calculated as follows:

$$N_{\text{TXU, counted}} = \min(N_{\text{TXU, active}}, 8 \times N_{\text{cells}}) \text{ for AAS BS in single RAT E-UTRA operation and MSR AAS BS (except UTRA only MSR AAS BS)}$$

and

$$N_{\text{TXU, counted}} = \min(N_{\text{TXU, active}}, 4 \times N_{\text{cells}}) \text{ for AAS BS in single RAT UTRA operation and UTRA only MSR AAS BS}$$

Further:

$$N_{\text{TXU, counted per cell}} = N_{\text{TXU, counted}} / N_{\text{cells}}$$

$N_{\text{TXU, counted per cell}}$ is used for scaling the *basic limits* as described in subclause 6.6.

NOTE: $N_{\text{TXU,active}}$ depends on the actual number of *active transmitter units* and is independent to the declaration of N_{cells} .

Any transmitter requirement specified for NB-IoT in-band, NB-IoT guard band, or standalone NB-IoT operation in 3GPP TS 36.104 [4] for E-UTRA with NB-IoT (in-band or guard band) or for standalone NB-IoT, or in 3GPP TS 37.104 [5] for E-UTRA with NB-IoT or standalone NB-IoT in *MSR operation*, and referred in clause 6, is not applicable for AAS BS.

Any transmitter requirement specified for Band 46 operation in 3GPP TS 36.104 [4] for E-UTRA, or in 3GPP TS 37.104 [5] for E-UTRA in *MSR operation*, and referred in clause 6, is not applicable for AAS BS.

6.2 Base station output power

6.2.1 General

The configured carrier power is the target maximum power for a specific carrier for the operating mode set in the BS within the limits given by the manufacturer's declaration.

6.2.2 Maximum output power

6.2.2.1 General

The rated carrier output power of the AAS BS shall be as specified in table 6.2.2.1-1.

Table 6.2.2.1-1: AAS BS rated output power limits for BS classes

AAS BS class	$P_{\text{Rated,c,sys}}$	$P_{\text{Rated,c,TABC}}$
Wide Area BS	(Note)	(Note)
Medium Range BS	$\leq 38 \text{ dBm} + 10\log(N_{\text{TXU,counted}})$	$\leq 38\text{dBm}$
Local Area BS	$\leq 24 \text{ dBm} + 10\log(N_{\text{TXU,counted}})$	$\leq 24\text{dBm}$
NOTE: There is no upper limit for the $P_{\text{Rated,c,sys}}$ or $P_{\text{Rated,c,TABC}}$ of the Wide Area Base Station.		

6.2.2.2 Minimum requirement for MSR operation

6.2.2.2.1 General

In normal conditions, $P_{\text{max,c,TABC}}$ shall remain within +2 dB and -2 dB of the configured carrier power for each *TAB connector* as declared by the manufacturer.

In extreme conditions, $P_{\text{max,c,TABC}}$ shall remain within +2,5 dB and -2,5 dB of the configured carrier power for each *TAB connector* as declared by the manufacturer.

In certain regions, the minimum requirement for normal conditions may apply also for some conditions outside the range of conditions defined as normal.

6.2.2.2.2 Additional requirements (regional)

For AAS BS operating E-UTRA in Japan in operating bands 34 or 41, $P_{\text{Rated,c,sys}}$ shall be within the limits set in 3GPP TS 37.104 [9], subclause 6.2.2.

6.2.2.3 Minimum requirement for single RAT UTRA operation

The minimum requirement for single RAT UTRA BS is the same as that defined in subclause 6.2.2.2.

6.2.2.4 Minimum requirement for single RAT E-UTRA operation

6.2.2.4.1 General

The minimum requirement for single RAT E-UTRA BS is the same as that defined in subclause 6.2.2.2.

6.2.2.4.2 Additional requirements (regional)

For AAS BS operating in Japan in operating bands 34 or 41, $P_{\text{Rated,c.sys}}$ shall be within the limits set in 3GPP TS 36.104 [8], subclause 6.2.2.

6.2.3 UTRA FDD primary CPICH power

6.2.3.1 General

This requirement applies to the *TAB connector* group(s) transmitting primary CPICH.

Primary CPICH (P-CPICH) power is the *code domain power* of the Primary Common Pilot Channel summed over the *TAB connectors* transmitting the P-CPICH for a cell. P-CPICH power is indicated on the BCH.

NOTE 1: A *TAB connector* group may comprise all *TAB connectors*.

NOTE 2: A *TAB connector* may be mapped to several groups.

NOTE 3: The manufacturer declares the *TAB connector* mapping to the P-CPICH transmission group(s) as specified in 3GPP TS 37.145 [13].

6.2.3.2 Minimum requirement for MSR operation

The minimum requirement for MSR UTRA FDD operation is the same as that defined in subclause 6.2.3.3. There is no CPICH power requirement for UTRA TDD 1,28 Mcps option operation.

There is no CPICH power requirement for E-UTRA operation.

6.2.3.3 Minimum requirement for single RAT UTRA operation

The difference between the P-CPICH power and the P-CPICH power indicated on the BCH shall be within $\pm 2,1$ dB.

Alternatively, the P-CPICH power measured at each *TAB connector* shall be within $\pm 2,1$ dB of the P-CPICH power level indicated on the BCH multiplied by a *TAB connector* specific beamforming weight. Beamforming weights on P-CPICH are set by the AAS BS to achieve an intended radiated pattern.

There is no P-CPICH power requirement for UTRA TDD 1,28 Mcps option operation.

6.2.3.4 Minimum requirement for single RAT E-UTRA operation

There is no CPICH power requirement for E-UTRA AAS BS.

6.2.4 UTRA TDD primary CCPCH power

6.2.4.1 General

This requirement applies to the *TAB connector* group(s) transmitting primary CCPCH. It comprises primary CCPCH (PCCPCH) absolute power accuracy, and differential accuracy.

Primary CCPCH power is the *code domain power* of the primary common control physical channel averaged over the transmit timeslot and summed over the *TAB connectors* transmitting the PCCPCH for a cell. Primary CCPCH power is signalled over the BCH.

The differential accuracy of the Primary CCPCH power is the relative transmitted power accuracy of PCCPCH in consecutive frames when the nominal PCCPCH power is not changed.

NOTE 1: A *TAB connector* group may comprise all *TAB connectors*.

NOTE 2: A *TAB connector* may be mapped to several groups.

NOTE 3: The manufacturer declares the *TAB connector* mapping to the PCCPCH transmission group(s).

6.2.4.2 Minimum requirement for MSR operation

The minimum requirement for MSR UTRA TDD 1,28 Mcps option operation is the same as that defined in subclause 6.2.4.3.

There is no CCPCH power requirement for UTRA FDD operation.

There is no CCPCH power requirement for E-UTRA operation.

6.2.4.3 Minimum requirement for single RAT UTRA operation

For UTRA TDD 1,28 Mcps option operation, the difference between the BCH-broadcast value of the Primary CCPCH power and the Primary CCPCH power averaged over the timeslot shall not exceed the values in table 6.2.4.3-1. The requirement is a function of the output power from the *TAB connector* group transmitting PCCPCH averaged over the transmit timeslot, P_{out} , and the manufacturer's rated total power of the group, $P_{rated,t,group}$.

Table 6.2.4.3-1: Difference between Primary CCPCH power and the broadcast value

Output power in slot, dB	PCCPCH power tolerance
$P_{rated,t,group} - 3 < P_{out} \leq P_{rated,t,group} + 2$	$\pm 2,5$ dB
$P_{rated,t,group} - 6 < P_{out} \leq P_{rated,t,group} - 3$	$\pm 3,5$ dB
$P_{rated,t,group} - 13 < P_{out} \leq P_{rated,t,group} - 6$	± 5 dB
NOTE: $P_{rated,t,group}$ is the power sum of $P_{rated,t,TABC}$ of all the <i>TAB connectors</i> in the group transmitting PCCPCH.	

The differential accuracy of PCCPCH power shall be within $\pm 0,5$ dB.

Alternatively, the PCCPCH power measured at each *TAB connector* and averaged over the timeslot shall be within the tolerance indicated in table 6.2.4.3-1 of the PCCPCH power level indicated on the BCH that is multiplied by a *TAB connector* specific beamforming weight. Beamforming weights on PCCPCH are set by the AAS BS to achieve an intended radiated pattern.

In this case, the differential accuracy of PCCPCH power shall be within $\pm 0,5$ dB on each *TAB connector* in the *TAB connector* group.

There is no PCCPCH power requirement for UTRA FDD operation.

6.2.4.4 Minimum requirement for single RAT E-UTRA operation

There is no CCPCH power requirement for E-UTRA operation.

6.2.5 UTRA FDD additional CPICH power for MIMO mode

6.2.5.1 General

This clause includes requirements on secondary CPICH power level, for two and four *TAB connector* groups, as well as Demodulation CPICH requirements. The requirements apply to all *TAB connector* groups associated with UTRA FDD MIMO transmission as "antenna 2", "antenna 3" or "antenna 4" in the AAS BS.

The concept of "antenna 2", "antenna 3" and "antenna 4" is described in 3GPP TS 25.104 [2]. The group(s) of *TAB connectors* mapped to P-CPICH transmission represents "antenna 1".

NOTE 1: The manufacturer declares the mapping of *TAB connectors* to "antenna 1", "antenna 2", "antenna 3" and "antenna 4" (as defined in 3GPP TS 25.331 [16]) where applicable for AAS BS capable of UTRA FDD operation. The required declarations are specified in 3GPP TS 37.145 [13].

For UTRA FDD AAS BS operating only "antenna 1" and "antenna 2", the secondary CPICH (S-CPICH) power is the *code domain power* of the Secondary Common Pilot Channel. S-CPICH power is equal to the (dB) sum of the P-CPICH power and the power offset, which are signalled to the UE. The power offset is signalled in the IE "Power Offset for S-CPICH for MIMO", for MIMO mode as defined in section 10.3.6.41b in 3GPP TS 25.331 [16].

When the UE supports MIMO mode with four BS transmit antennas, the power offset of S-CPICH on antenna 2 is signalled in the IE "Power Offset for S-CPICH for MIMO mode with four transmit antennas on Antenna2" as defined in subclause 10.3.6.143 in 3GPP TS 25.331 [16]. The power offset of S-CPICH on antenna 3 and 4 is signalled in the IE "Common Power Offset for S-CPICH for MIMO mode with four transmit antennas on Antenna3 and 4", as defined in subclause 10.3.6.143 in 3GPP TS 25.331 [16].

Demodulation CPICH (D-CPICH) power is the *code domain power* of the Demodulation Common Pilot Channel. D-CPICH power is equal to the (dB) sum of the P-CPICH power and the power offset, which are signalled to the UE. The power offset of D-CPICH on antenna 3 and 4 is signalled in the IE "Common Power Offset for D-CPICH for MIMO mode with four transmit antennas on Antenna3 and 4", as defined in subclause 10.3.6.143 in 3GPP TS 25.331 [16].

NOTE 2: The accuracy level of the power offset for S-CPICH may affect both MIMO HS-DSCH demodulation and CQI reporting performance.

NOTE 3: The accuracy level of the power offset for D-CPICH transmitted on antennas 3 and 4 may affect both MIMO HS-DSCH demodulation and CQI reporting performance.

NOTE 4: At high geometry level PDSCH performance may be affected if D-CPICH is not scheduled.

NOTE 5: A *TAB connector* group may comprise all *TAB connectors*.

NOTE 6: A *TAB connector* may be mapped to several groups.

6.2.5.2 Minimum requirement for MSR operation

The minimum requirements for MSR UTRA FDD operation are the same as those defined in subclause 6.2.5.3.

There is no CPICH power requirement for UTRA TDD 1,28 Mcps option operation.

There is no CPICH power requirement for E-UTRA operation.

6.2.5.3 Minimum requirement for single RAT UTRA operation

When operating MIMO only "antenna 1" and "antenna 2";

The difference between the P-CPICH power transmitted at the group of *TAB connectors* mapped to "antenna 1", and the S-CPICH power transmitted at the corresponding group of *TAB connectors* mapped to "antenna 2" shall be within ± 2 dB of the IE "Power Offset for S-CPICH for MIMO".

Alternatively, the measured power of the P-CPICH mapped to "antenna 1" and the measured power of the S-CPICH mapped to "antenna 2" at each *TAB connector* shall be within 2 dB of the corresponding IE "Power Offset for S-CPICH for MIMO" that is multiplied by a *TAB connector* specific beamforming weight and the P-CPICH power level indicated on the BCH. The same beamforming weights applied to P-CPICH and S-CPICH are set by the AAS BS to achieve an intended radiated pattern.

When operating MIMO "antenna 1", "antenna 2", "antenna 3", and "antenna 4".

The difference between the P-CPICH power transmitted at the group of *TAB connectors* mapped to "antenna 1", and the S-CPICH power transmitted at the corresponding group of *TAB connectors* mapped to "antenna 2" shall be within ± 2 dB of the IE "Power Offset for S-CPICH for MIMO mode with four transmit antennas on Antenna2".

The difference between the P-CPICH power transmitted at the group of *TAB connectors* mapped to "antenna 1" and the S-CPICH power transmitted at the corresponding groups of *TAB connectors* mapped to "antenna 3" and "antenna 4"

respectively, shall be within ± 2 dB of the IE "Common Power Offset for S-CPICH for MIMO mode with four transmit antennas on Antenna3 and 4".

Alternatively, the measured power of the P-CPICH mapped to "antenna 1" and the measured power of the S-CPICH mapped to "antenna 2" at each *TAB connector* shall be within ± 2 dB of the corresponding IE "Power Offset for S-CPICH for MIMO mode with four transmit antennas on Antenna2" that is multiplied by a *TAB connector* specific beamforming weight and the P-CPICH power level indicated on the BCH. The measured power of the P-CPICH mapped to "antenna 1" and the measured power of the S-CPICH mapped to "antenna 3" and "antenna 4", respectively, at each *TAB connector* shall be within ± 2 dB of the corresponding IE "Power Offset for S-CPICH for MIMO mode with four transmit antennas on Antenna3 and 4" that is multiplied by a *TAB connector* specific beamforming weight and the P-CPICH power level indicated on the BCH. The same beamforming weights applied to P-CPICH and S-CPICH are set by the AAS BS to achieve an intended radiated pattern.

If D-CPICH is scheduled:

The difference between the P-CPICH power transmitted at the group of *TAB connectors* mapped to "antenna 1" and the D-CPICH power transmitted at the corresponding groups of *TAB connectors* mapped to "antenna 3" and "antenna 4" respectively, shall be within ± 2 dB of the IE "Common Power Offset for D-CPICH for MIMO mode with four transmit antennas on Antenna3 and 4".

Alternatively, the measured power of the P-CPICH mapped to "antenna 1" and the measured power of the D-CPICH mapped to "antenna 3" and "antenna 4", respectively, at each *TAB connector* shall be within ± 2 dB of the corresponding IE "Common Power Offset for D-CPICH for MIMO mode with four transmit antennas on Antenna3 and 4" that is multiplied by a *TAB connector* specific beamforming weight and the P-CPICH power level indicated on the BCH. The same beamforming weights applied to P-CPICH and D-CPICH are set by the AAS BS to achieve an intended radiated pattern.

There is no CPICH power requirement for UTRA TDD 1,28 Mcps option operation.

6.2.5.4 Minimum requirement for single RAT E-UTRA operation

There is no CPICH power requirement for E-UTRA AAS BS.

6.2.6 E-UTRA DL RS power

6.2.6.1 General

This requirement applies to the *TAB connector* group(s) transmitting primary DL RS.

The DL RS power is the resource element power of the Downlink Reference Symbol summed over the group of *TAB connectors* transmitting the DL RS for a cell.

The absolute DL RS power is indicated on the DL-SCH. The absolute accuracy is defined as the maximum deviation between the DL RS power indicated on the DL-SCH and the DL RS power of each E-UTRA carrier.

NOTE 1: A *TAB connector* group may comprise all *TAB connectors*.

NOTE 2: A *TAB connector* may be mapped to several groups.

NOTE 3: The manufacturer declares the *TAB connector* mapping to the DL RS transmission group(s).

6.2.6.2 Minimum requirement for MSR operation

There is no DL RS power requirement for UTRA operation.

The minimum requirement for MSR E-UTRA operation is the same as that defined in subclause 6.2.6.4.

6.2.6.3 Minimum requirement for single RAT UTRA operation

There is no DL RS power requirement for UTRA operation.

6.2.6.4 Minimum requirement for single RAT E-UTRA operation

The DL RS power of each E-UTRA carrier shall be within $\pm 2,1$ dB of the DL RS power indicated on the DL-SCH.

Alternatively, the DL RS power measured at each *TAB connector* shall be within $\pm 2,1$ dB of the DL RS power level indicated on the DL-SCH multiplied by a *TAB connector* specific beamforming weight. Beamforming weights on P-CPICH are set by the AAS BS to achieve an intended radiated pattern.

6.3 Output power dynamics

6.3.1 General

The requirements in subclause 6.3 apply during the *transmitter ON period*. Transmit signal quality (as specified in subclause 6.5) shall be maintained for the output power dynamics requirements.

6.3.2 UTRA Inner loop power control in the downlink

6.3.2.1 General

Inner loop power control in the downlink is the ability of the AAS BS to adjust the transmitted output power of a code channel in accordance with the corresponding TPC commands received in the uplink.

This requirement applies at each *TAB connector* supporting transmission in the operating band.

6.3.2.2 Minimum requirement for MSR operation

For UTRA FDD operation; the minimum requirements for MSR AAS BS inner loop power control in the DL are the same as in subclause 6.3.2.3.

For UTRA TDD 1,28 Mcps option operation; the minimum requirements for MSR AAS BS inner loop power control in the DL are the same as in 3GPP TS 25.105 [7], subclause 6.4.2.1.

This requirement does not apply to E-UTRA operation.

6.3.2.3 Minimum requirement for single RAT UTRA operation

For UTRA FDD operation, the Single RAT AAS BS shall have the capability of setting the inner loop *code domain power* on each *TAB connector* with a step sizes of 1dB mandatory and 0.5, 1.5, 2.0 dB optional

- The tolerance of the power control step due to inner loop power control shall be within the range shown in table 6.3.2.3-1.
- The tolerance of the combined output power change due to inner loop power control shall be within the range shown in table 6.3.2.3-2.

Table 6.3.2.3-1: UTRA FDD *TAB connector* power control step tolerance

Power control commands in the down link	Transmitter power control step tolerance							
	2 dB step size		1,5 dB step size		1 dB step size		0,5 dB step size	
	Lower	Upper	Lower	Upper	Lower	Upper	Lower	Upper
Up (TPC command "1")	+1,0 dB	+3,0 dB	+0,75 dB	+2,25 dB	+0,5 dB	+1,5 dB	+0,25 dB	+0,75 dB
Down (TPC command "0")	-1,0 dB	-3,0 dB	-0,75 dB	-2,25 dB	-0,5 dB	-1,5 dB	-0,25 dB	-0,75 dB

Table 6.3.2.3-2: UTRA FDD *TAB connector* aggregated power control step range

Power control commands in the down link	Transmitter aggregated power control step change after 10 consecutive equal commands (up or down)							
	2 dB step size		1,5 dB step size		1 dB step size		0,5 dB step size	
	Lower	Upper	Lower	Upper	Lower	Upper	Lower	Upper
Up (TPC command "1")	+16 dB	+24 dB	+12 dB	+18 dB	+8 dB	+12 dB	+4 dB	+6 dB
Down (TPC command "0")	-16 dB	-24 dB	-12 dB	-18 dB	-8 dB	-12 dB	-4 dB	-6 dB

For UTRA TDD 1,28 Mcps option operation; the minimum requirements for single RAT AAS BS inner loop power control in the DL are the same as in 3GPP TS 25.105 [7], subclause 6.4.2.1.

6.3.2.4 Minimum requirement for single RAT E-UTRA operation

This requirement does not apply to E-UTRA operation.

6.3.3 Power control dynamic range

6.3.3.1 General

The power control dynamic range is the difference between the maximum and the minimum *code domain power* of a code channel for a specified reference condition.

This requirement applies at each *TAB connector* supporting transmission in the operating band.

6.3.3.2 Minimum requirement for MSR operation

For UTRA FDD operation; the minimum requirements for MSR AAS BS power control dynamic range are the same as in 3GPP TS 25.104 [6], subclause 6.4.2.1.

For UTRA TDD 1,28 Mcps option operation; the minimum requirement for MSR AAS BS power control dynamic range is the same as in 3GPP TS 25.105 [7], subclause 6.4.3.1.

This requirement does not apply to E-UTRA operation.

6.3.3.3 Minimum requirement for single RAT UTRA operation

For UTRA FDD operation; the minimum requirements for single RAT AAS BS power control dynamic range are the same as in 3GPP TS 25.104 [6], subclause 6.4.2.1.

For UTRA TDD 1,28 Mcps option operation; the minimum requirement for single RAT AAS BS power control dynamic range is the same as in 3GPP TS 25.105 [7], subclause 6.4.3.1.

6.3.3.4 Minimum requirement for single RAT E-UTRA operation

This requirement does not apply to E-UTRA operation.

6.3.4 Total power dynamic range

6.3.4.1 General

The total power dynamic range is the difference between the maximum and the minimum output power for a specified reference condition.

This requirement applies at each *TAB connector* supporting transmission in the operating band.

NOTE 1: The upper limit of the dynamic range is the BS maximum output power ($P_{\text{Rated,c,TABC}}$). The lower limit of the dynamic range is the lowest minimum power from the BS when no traffic channels are activated.

Particularly for E-UTRA, the total power dynamic range is the difference between the maximum and the minimum transmit power of an OFDM symbol for a specified reference condition.

NOTE 2: The upper limit of the dynamic range at a *TAB connector* is the OFDM symbol power at maximum output power ($P_{\text{Rated,c,TABC}}$). The lower limit of the dynamic range at a *TAB connector* is the OFDM symbol power when one resource block is transmitted. The OFDM symbol carries PDSCH and not contain RS, PBCH or synchronization signals.

6.3.4.2 Minimum requirement for MSR operation

For UTRA FDD operation; the minimum requirements for MSR AAS BS total power dynamic range are the same as in 3GPP TS 25.104 [6], subclause 6.4.3.1.

This requirement does not apply to UTRA TDD operation.

For E-UTRA operation, the minimum requirements for MSR AAS BS total power dynamic range are the same as in 3GPP TS 36.104 [8], subclause 6.3.2.1.

6.3.4.3 Minimum requirement for single RAT UTRA operation

For UTRA FDD operation; the minimum requirements for single RAT AAS BS total power dynamic range are the same as in 3GPP TS 25.104 [6], subclause 6.4.3.1.

This requirement does not apply to UTRA TDD operation.

6.3.4.4 Minimum requirement for single RAT E-UTRA operation

For E-UTRA operation; the minimum requirements for single RAT AAS BS total power dynamic range are the same as in 3GPP TS 36.104 [8], subclause 6.3.2.1.

6.3.5 IPDL time mask

6.3.5.1 General

To support IPDL location method in UTRA FDD operation, the AAS BS shall interrupt all transmitted signals in the downlink (i.e. common and dedicated channels). The IPDL time mask specifies the limits of the *TAB connector* output power during these idle periods.

This requirement applies only to AAS BS supporting IPDL. The requirement applies at each *TAB connector* supporting transmission in the operating band.

6.3.5.2 Minimum requirement for MSR operation

For UTRA FDD operation; the minimum requirement for MSR AAS BS IPDL time mask is the same as in 3GPP TS 25.104 [6], subclause 6.4.5.1.

This requirement does not apply to UTRA TDD operation.

This requirement does not apply to E-UTRA operation.

6.3.5.3 Minimum requirement for single RAT UTRA operation

For UTRA FDD operation; the minimum requirement for single RAT AAS BS IPDL time mask is the same as in 3GPP TS 25.104 [6], subclause 6.4.5.1.

This requirement does not apply to UTRA TDD operation.

6.3.5.4 Minimum requirement for single RAT E-UTRA operation

This requirement does not apply to E-UTRA operation.

6.3.6 RE Power control dynamic range

6.3.6.1 General

The RE power control dynamic range is the difference between the power of an RE and the average RE power for a BS at maximum output power ($P_{\text{Rated,c,TABC}}$) for a specified reference condition.

This requirement applies at each *TAB connector* supporting transmission in the operating band.

6.3.6.2 Minimum requirement for MSR operation

This requirement does not apply to UTRA operation.

For E-UTRA operation; the minimum requirements for MSR AAS BS RE power control dynamic range are the same as in 3GPP TS 36.104 [8], subclause 6.3.1.1.

6.3.6.3 Minimum requirement for single RAT UTRA operation

This requirement does not apply to UTRA operation.

6.3.6.4 Minimum requirement for single RAT E-UTRA operation

For E-UTRA operation; the minimum requirements for single RAT AAS BS RE power control dynamic range are the same as in 3GPP TS 36.104 [8], subclause 6.3.1.1.

6.4 Transmit ON/OFF power

6.4.1 General

Transmitter ON/OFF power requirements apply only to TDD operation of UTRA and E-UTRA.

6.4.2 Transmitter OFF power

6.4.2.1 General

Transmitter OFF power is defined as the mean power measured over 70 μs filtered with a square filter of bandwidth equal to the Base Station RF Bandwidth (s) centred on the central frequency of the Base Station RF Bandwidth (s) during the *transmitter OFF period*.

The requirement applies at each *TAB connector* supporting transmission in the operating band.

For *multi-band TAB connectors*, the requirement is only applicable during the *transmitter OFF period* in all supported operating bands.

For *single band TAB connectors* supporting transmission in multiple operating bands, the requirement is applicable per supported operating band.

6.4.2.2 Minimum requirement for MSR operation

The transmitter OFF power spectral density shall be less than -85 dBm/MHz.

6.4.2.3 Minimum requirement for single RAT UTRA operation

The minimum requirement for UTRA operation is the same as that defined in subclause 6.4.2.2.

6.4.2.4 Minimum requirement for single RAT E-UTRA operation

The minimum requirement for UTRA operation is the same as that defined in subclause 6.4.2.2.

6.4.3 Transmitter transient period

6.4.3.1 General

The *transmitter transient period* is the time period during which the transmitter unit is changing from the OFF period to the ON period or vice versa. The *transmitter transient period* is illustrated in figure 6.4.3.1-1.

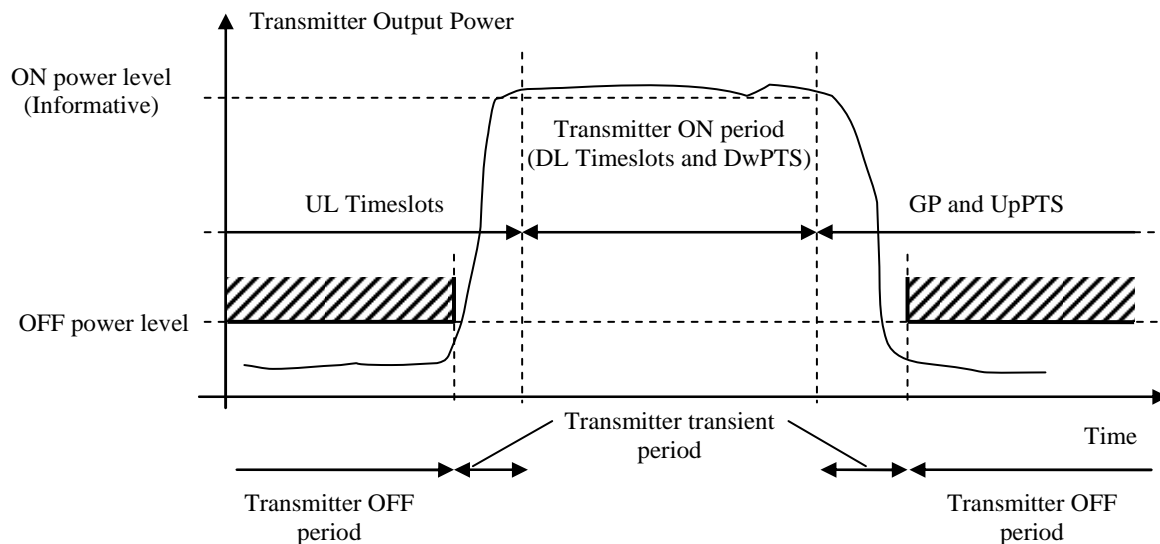

Figure 6.4.3.1-1: Illustration of the relations of *transmitter ON period*, *transmitter OFF period* and *transmitter transient period*

This requirement applies at each *TAB connector* supporting transmission in the operating band.

6.4.3.2 Minimum requirement for MSR operation

The minimum requirements for MSR AAS BS *transmitter transient period* are the same as in 3GPP TS 37.104 [9], subclause 6.4.2.1.

6.4.3.3 Minimum requirement for single RAT UTRA operation

The minimum requirements for single RAT AAS BS *transmitter transient period* are the same as in 3GPP TS 25.105 [7], subclause 6.5.2.1.2.

6.4.3.4 Minimum requirement for single RAT E-UTRA operation

The minimum requirements for single RAT AAS BS *transmitter transient period* are the same as in 3GPP TS 36.104 [8], subclause 6.4.2.1.

6.5 Transmitted signal quality

6.5.1 General

Unless otherwise stated, the requirements in clause 6.5 apply during the *Transmitter ON period*.

6.5.2 Frequency Error

6.5.2.1 General

This requirement applies per *TAB connector*.

The requirement applies during the *transmitter ON period*.

Frequency error is the measure of the difference between the actual AAS BS transmit frequency and the assigned frequency. The same source shall be used for RF frequency and data clock generation.

6.5.2.2 Minimum requirement for MSR operation

The minimum requirement for a UTRA frequency error is the same as defined in subclause 6.5.2.3.

The minimum requirement for an E-UTRA frequency error is the same as defined in subclause 6.5.2.4.

6.5.2.3 Minimum requirement for single RAT UTRA operation

The single RAT UTRA FDD AAS BS of wide area BS class shall fulfil the frequency error minimum requirements for wide area BS described in 3GPP TS 25.104 [6], subclause 6.3.1.

The single RAT UTRA FDD AAS BS of medium range BS class shall fulfil the frequency error minimum requirements for medium range BS described in 3GPP TS 25.104 [6], subclause 6.3.1.

The single RAT UTRA FDD AAS BS of local area BS class shall fulfil the frequency error minimum requirements for local area BS described in 3GPP TS 25.104 [6], subclause 6.3.1.

The single RAT UTRA TDD 1,28Mcps option AAS BS of wide area BS class shall fulfil the frequency error minimum requirements for wide area BS described in 3GPP TS 25.105 [7], subclause 6.3.1.2.

The single RAT UTRA TDD 1,28Mcps option AAS BS of local area BS class shall fulfil the frequency error minimum requirements for local area BS described in 3GPP TS 25.105 [7], subclause 6.3.1.2.

6.5.2.4 Minimum requirement for single RAT E-UTRA operation

The single RAT E-UTRA AAS BS of wide area BS class shall fulfil the frequency error minimum requirements for wide area BS described in 3GPP TS 36.104 [8], subclause 6.5.1.1.

The single RAT E-UTRA AAS BS of medium range BS class shall fulfil the frequency error minimum requirements for medium range BS described in 3GPP TS 36.104 [8], subclause 6.5.1.1.

The single RAT E-UTRA AAS BS of local area BS class shall fulfil the frequency error minimum requirements for local area BS described in 3GPP TS 36.104 [8], subclause 6.5.1.1.

6.5.3 Time alignment error

6.5.3.1 General

This requirement applies to frame timing in:

- UTRA single/multi-carrier transmissions and their combinations with MIMO or TX diversity.
- E-UTRA single/multi-carrier transmissions and their combinations with MIMO or TX diversity.
- E-UTRA *carrier aggregation*, with or without MIMO or TX diversity.

Frames of the WCDMA/LTE signals present at the *TAB connectors* are not perfectly aligned in time. In relation to each other, the RF signals present at the *transceiver array boundary* may experience certain timing differences.

For a specific set of signals/transmitter configuration/transmission mode, the Time Alignment Error (TAE) is defined as the largest timing difference between any two different LTE signals or any two different WCDMA signals belonging to different *TAB Connectors* belonging to different transmitter groups at the *transceiver array boundary*, where transmitter groups are associated with the *TAB connectors* in the transceiver unit array corresponding to TX diversity, MIMO transmission, *carrier aggregation*, etc.

6.5.3.2 Minimum requirement for MSR operation

The minimum requirement for a UTRA time alignment error is the same as defined in subclause 6.5.3.3.

The minimum requirement for an E-UTRA time alignment error is the same as defined in subclause 6.5.3.4.

6.5.3.3 Minimum requirement for single RAT UTRA operation

This requirement applies to frame timing in Tx diversity, MIMO transmission, DC-HSDPA, DB-DC-HSDPA, 4C-HSDPA, NC-4C-HSDPA, 8C-HSDPA and their combinations.

The TAE between any two *TAB connectors* from different transmitter groups shall not exceed the specified minimum requirements below.

For UTRA FDD, the minimum requirement for time alignment are the same as those in 3GPP TS 25.104 [6], subclause 6.8.4.1.

For UTRA TDD, the minimum requirement for time alignment are the same as those in 3GPP TS 25.105 [7], subclause 6.8.5.1.

6.5.3.4 Minimum requirement for single RAT E-UTRA operation

This requirement applies to frame timing in TX diversity, MIMO transmission, *carrier aggregation* and their combinations.

The TAE between any two *TAB connectors* from different transmitter groups shall not exceed the specified minimum requirements below.

For E-UTRA, the minimum requirement for time alignment are the same as those in 3GPP TS 36.104 [8], subclause 6.5.3.1.

6.5.4 Modulation quality

6.5.4.1 General

Modulation quality is defined by the difference between the measured carrier signal and a reference signal. Modulation quality can be expressed e.g. as Peak Code domain Error (PCDE) or Relative Code domain Error (RCDE) or Error Vector Magnitude (EVM) for UTRA and Error Vector Magnitude (EVM) for E-UTRA.

These requirements apply per *TAB connector*.

6.5.4.2 Minimum requirement for MSR operation

The minimum requirement for a UTRA modulation quality are defined in subclause 6.5.4.3.

The minimum requirement for an E-UTRA modulation quality are defined in subclause 6.5.4.4.

6.5.4.3 Minimum requirement for single RAT UTRA operation

The Error Vector Magnitude is a measure of the difference between the reference waveform and the measured waveform. This difference is called the error vector. Both waveforms pass through a matched Root Raised Cosine filter to the considered chip rate and roll-off $\alpha=0.22$. Both waveforms are then further modified by selecting the frequency, absolute phase, absolute amplitude and chip clock timing to minimize the error vector. The EVM result is defined as the square root of the ratio of the mean error vector power to the mean reference power expressed as a %.

For UTRA FDD the measurement interval is one timeslot as defined by the C-PICH (when present) otherwise the measurement interval is one timeslot starting with the beginning of the SCH. The requirement is valid over the total power dynamic range as specified in subclause 6.3.4.3. The minimum requirements are the same as those in 3GPP TS 25.104 [6], subclause 6.8.2.1.

For UTRA TDD the measurement interval is one timeslot. The requirement is valid over the total power dynamic range as specified in subclause 6.3.4.3. See annex C of 3GPP TS 25.142 [10] for further details. The minimum requirements are the same as those in 3GPP TS 25.105 [7], subclause 6.8.2.1.

For UTRA FDD the Peak Code Domain Error is computed by projecting the error vector onto the code domain at a specified spreading factor. The Code Domain Error for every code in the domain is defined as the ratio of the mean power of the projection onto that code, to the mean power of the composite reference waveform. This ratio is expressed in dB. The Peak Code Domain Error is defined as the maximum value for the Code Domain Error for all codes. The measurement interval is one timeslot as defined by the C-PICH (when present) otherwise the measurement interval is one timeslot starting with the beginning of the SCH. The minimum requirements are the same as those in 3GPP TS 25.104 [6], subclause 6.8.3.1.

For UTRA FDD the Relative Code Domain Error is computed by projecting the error vector onto the code domain at a specified spreading factor. Only the active code channels in the composite reference waveform are considered for this requirement. The Relative Code Domain Error for every active code is defined as the ratio of the mean power of the error projection onto that code, to the mean power of the active code in the composite reference waveform. This ratio is expressed in dB. The measurement interval is one frame. The minimum requirements are the same as those in 3GPP TS 25.104 [6], subclause 6.8.5.1.

For UTRA TDD 1,28Mcps option, the minimum requirements for modulation quality, PCDE and RCDE, are the same as in 3GPP TS 25.105 [7], subclauses 6.8.2, 6.8.3 and 6.8.4 respectively. The requirement for Relative Code Domain Error is only applicable for 64QAM modulated codes (UTRA FDD and UTRA TDD).

6.5.4.4 Minimum requirement for single RAT E-UTRA operation

For E-UTRA, the minimum requirement for modulation quality, EVM, is specified in 3GPP TS 36.104 [8], subclause 6.5.2.

6.5.5 Transmit pulse shape filter

6.5.5.1 General

This requirement applies per *TAB connector*.

6.5.5.2 Minimum requirement for MSR operation

The requirement for a UTRA pulse shape filter is defined in subclause 6.5.5.3.

There is no pulse shape filter requirement for an E-UTRA AAS BS.

6.5.5.3 Minimum requirement for single RAT UTRA operation

For UTRA FDD, the UTRA transmit pulse shape filter is defined in 3GPP TS 25.104 [6], subclause 6.8.1.

For UTRA TDD, the UTRA transmit pulse shape filter is defined in 3GPP TS 25.105 [7], subclause 6.8.1.

6.5.5.4 Minimum requirement for single RAT E-UTRA operation

There is no pulse shape filter requirement for an E-UTRA AAS BS.

6.6 Unwanted Emissions

6.6.1 General

Unwanted emissions consist of so-called out-of-band emissions and spurious emissions according to ITU definitions 3GPP TS 25.331 [14]. In ITU terminology, out of band emissions are unwanted emissions immediately outside the *channel bandwidth* resulting from the modulation process and non-linearity in the transmitter but excluding spurious emissions. Spurious emissions are emissions which are caused by unwanted transmitter effects such as harmonics

emission, parasitic emission, intermodulation products and frequency conversion products, but exclude out of band emissions.

For AAS BS in *single RAT E-UTRA operation* and *MSR operation*, the out-of-band emissions requirement for the BS transmitter is specified in terms of an Operating band unwanted emissions requirement that defines limits for emissions in each supported *downlink operating band* plus the frequency ranges 10 MHz above and 10 MHz below each band. Emissions outside of this frequency range are limited by a spurious emissions requirement. For UTRA single RAT AAS BS, the out of band emission requirement for BS transmitter is specified in terms of Spectrum emission mask.

The unwanted emission level limit of a *TAB connector TX min cell group* is in general defined by the unwanted emission *basic limit* which is the same as the corresponding applicable *non-AAS BS* per transmitter requirement specified in 3GPP TS 25.104 [2], 3GPP TS 25.105 [3], 3GPP TS 36.104 [4] or 3GPP TS 37.104 [5], and its scaling by $N_{\text{TXU, counted per cell}}$. The unwanted emission requirements are applied per the *TAB connector TX min cell groups* for all the configurations supported by the AAS BS. The *basic limits* and corresponding scaling are defined in each relevant subclause.

There is in addition a requirement for occupied bandwidth and an ACLR requirement.

6.6.2 Occupied bandwidth

6.6.2.1 General

The occupied bandwidth is the width of a frequency band such that, below the lower and above the upper frequency limits, the mean powers emitted are each equal to a specified percentage $\beta/2$ of the total mean transmitted power. See also Recommendation ITU-R SM.328 [17].

The value of $\beta/2$ shall be taken as 0.5%.

The occupied bandwidth requirement applies during the *transmitter ON period* for a single transmitted carrier. The minimum requirement below may be applied regionally. There may also be regional requirements to declare the occupied bandwidth according to the definition in the present clause.

6.6.2.2 Minimum requirement for MSR operation

For MSR AAS BS, the minimum requirement for occupied bandwidth is the same as that stated in 3GPP TS 37.104 [9], subclause 6.6.3.

6.6.2.3 Minimum requirement for single RAT UTRA operation

For single RAT UTRA FDD AAS BS, the minimum requirement for occupied bandwidth is the same as that stated in 3GPP TS 25.104 [6] subclause 6.6.1.

For single RAT UTRA TDD, 1,28Mcps option AAS BS, the minimum requirement for occupied bandwidth is the same as that stated in 3GPP TS 25.105 [7], subclause 6.6.1.

6.6.2.4 Minimum requirement for single RAT E-UTRA operation

For single RAT E-UTRA AAS BS, the minimum requirement for occupied bandwidth is the same as that stated in 3GPP TS 36.104 [8], subclause 6.6.1.

6.6.3 Adjacent Channel Leakage power Ratio

6.6.3.1 General

Adjacent Channel Leakage power Ratio (ACLR) is the ratio of the filtered mean power centred on the assigned channel frequency to the filtered mean power centred on an adjacent channel frequency.

NOTE: Conformance to the AAS BS ACLR requirement can be demonstrated by meeting at least one of the following criteria as determined by the manufacturer:

- 1) The ratio of the sum of the filtered mean power measured on each *TAB connector* in the *TAB connector TX min cell group* at the assigned channel frequency to the sum of the filtered mean power measured on each *TAB connector* in the *TAB connector TX min cell group* at the adjacent channel frequency shall be greater than or equal to the ACLR limit of AAS BS. This applies for each *TAB connector TX min cell group*.

Or

- 2) The ratio of the filtered mean power at the *TAB connector* centred on the assigned channel frequency to the filtered mean power at each *TAB connector* centred on the adjacent channel frequency shall be greater than or equal to the ACLR limit of AAS BS for every *TAB connector* in the *TAB connector TX min cell group*, for each *TAB connector TX min cell group*.

In case the ACLR absolute limit of AAS BS is applied, the conformance can be demonstrated by meeting at least one of the following criteria as determined by the manufacturer:

- 1) The sum of the filtered mean power measured on each *TAB connector* in the *TAB connector TX min cell group* at the adjacent channel frequency shall be less than or equal to the ACLR absolute limit AAS BS. This applies to each *TAB connector TX min cell group*.

Or

- 2) The filtered mean power at each *TAB connector* centred on the adjacent channel frequency shall be less than or equal to the ACLR absolute limit of AAS BS scaled by $-10\log_{10}(n)$ for every *TAB connector* in the *TAB connector TX min cell group*, for each *TAB connector TX min cell group*, where n is the number of *TAB connectors* in the *TAB connector TX min cell group*.

6.6.3.2 Minimum requirement for MSR operation

For E-UTRA operation, the ACLR limits for AAS BS are the same as those specified in 3GPP TS 37.104 [9] subclauses 6.6.4.1. The *basic limits* are also the same as the absolute limits of MSR E-UTRA operation specified in 3GPP TS 37.104 [9] subclauses 6.6.4.1. The ACLR absolute limit of AAS BS is specified as the *basic limit* + $10\log_{10}(N_{\text{TXU, counted per cell}})$. The ACLR limit or the ACLR absolute limit of AAS BS, whichever is less stringent, shall apply outside the *Base Station RF Bandwidth* or *Radio Bandwidth*.

For UTRA FDD operation, the minimum requirement for ACLR are the same as those specified in 3GPP TS 25.104 [6], subclause 6.6.2.2, and applies outside the *Base Station RF Bandwidth* or *Radio Bandwidth*.

For UTRA TDD 1,28 Mcps option operation, the minimum requirement for ACLR are the same as those specified in 3GPP TS 25.105 [7], subclause 6.6.2.2.1.2, and applies outside the *Base Station RF Bandwidth* or *Radio Bandwidth*.

For a *TAB connector* or *TAB connector cell group* supporting operation in *non-contiguous spectrum*, the ACLR requirement also applies for the first adjacent channel inside any *sub-block gap* with a gap size $W_{\text{gap}} \geq 15\text{MHz}$. The ACLR requirement for the second adjacent channel applies inside any *sub-block gap* with a gap size $W_{\text{gap}} \geq 20\text{MHz}$.

CACLR requirements apply in *sub-block gaps* as defined in 3GPP TS 37.104 [9], subclause 6.6.4.4. Either the CACLR limit or the ACLR absolute limit of AAS BS shall apply, whichever is less stringent.

For a *multi-band TAB connector* or *TAB connector cell group* supporting operation in multiple operating bands through *multi-band TAB connectors*, the ACLR requirement also applies for the first adjacent channel inside any *Inter RF Bandwidth gap* with a gap size $W_{\text{gap}} \geq 15\text{MHz}$. The ACLR requirement for the second adjacent channel applies inside any *Inter RF Bandwidth gap* with a gap size $W_{\text{gap}} \geq 20\text{MHz}$.

CACLR requirements apply in *Inter RF Bandwidth gaps* as defined in 3GPP TS 37.104 [9], subclause 6.6.4.4. Either the CACLR limit or the ACLR absolute limit of AAS BS shall apply, whichever is less stringent.

6.6.3.3 Minimum requirement for single RAT UTRA operation

For single RAT UTRA FDD operation, the AAS BS ACLR minimum requirements are the same as those specified in 3GPP TS 25.104 [6], subclauses 6.6.2.2.1.

For single RAT UTRA FDD operation, the AAS BS CACLR limits are the same as those specified in 3GPP TS 25.104 [6], subclauses 6.6.2.2.2. The *basic limits* are also the same as the absolute limits of UTRA specified in 3GPP TS 25.104 [6], subclauses 6.6.2.2.2. The ACLR absolute limit of AAS BS is specified as the *basic limit* + $10\log_{10}(N_{\text{TXU, countedpercell}})$. The CACLR limit or the ACLR absolute limit of AAS BS shall apply, whichever is less stringent.

For single RAT UTRA TDD 1,28 Mcps option operation, the AAS BS minimum requirements are the same as those specified in 3GPP TS 25.105 [7], subclause 6.6.2.2.

6.6.3.4 Minimum requirement for single RAT E-UTRA operation

For *single RAT E-UTRA operation*, the AAS BS ACLR and CACLR limits are the same as those specified in 3GPP TS 36.104 [8], subclauses 6.6.2.1 and 6.6.2.2. The *basic limits* are also the same as the absolute limits of E-UTRA specified in 3GPP TS 36.104 [8], subclauses 6.6.2.1 and 6.6.2.2. The ACLR absolute limit of AAS BS is specified as the *basic limit* + $10\log_{10}(N_{\text{TXU, countedpercell}})$. The ACLR (CACLR) limit or the ACLR absolute limit of AAS BS shall apply, whichever is less stringent.

6.6.4 Spectrum emission mask

6.6.4.1 General

This requirement is applicable for single RAT UTRA AAS BS operation only.

6.6.4.2 Minimum requirement for MSR operation

There is no spectrum emission mask requirement for an MSR AAS BS.

6.6.4.3 Minimum requirement for single RAT UTRA operation

6.6.4.3.1 General

The spectrum emission mask requirements for a UTRA single RAT AAS BS are that for each applicable *basic limit* as specified in 3GPP TS 25.104 [2] or TS 25.105 [7], and for each *TAB connector TX min cell group* the power sum of emissions at the *TAB connectors* of the *TAB connector TX min cell group* shall not exceed an AAS BS limit specified as the *basic limits* + $10\log_{10}(N_{\text{TXU, countedpercell}})$.

NOTE: Conformance to the AAS BS spectrum emission mask requirement can be demonstrated by meeting at least one of the following criteria as determined by the manufacturer:

- 1) The sum of the emissions power measured on each *TAB connector* in the *TAB connector TX min cell group* shall be less than or equal to the AAS limit as defined in this subclause for the respective frequency span.

Or

- 2) The spectrum emission mask power at each *TAB connector* shall be less than or equal to the AAS BS limit as defined in this subclause for the respective frequency span, scaled by $-10\log_{10}(n)$, where n is the number of *TAB connectors* in the *TAB connector TX min cell group*.

6.6.4.3.2 Basic limits for single RAT UTRA FDD operation

The *basic limit* is specified in tables 6.6.4.3.2-1 to 6.6.4.3.2-10 for the appropriate $P_{\text{Rated, c, sys}}$, where:

- Δf is the separation between the carrier frequency and the nominal -3 dB point of the measuring filter closest to the carrier frequency.
- f_{offset} is the separation between the carrier frequency and the centre of the measurement filter;
- $f_{\text{offset}_{\text{max}}}$ is either 12.5 MHz or the offset to the UMTS Tx band edge as defined in clause 3.4.1, whichever is the greater.
- Δf_{max} is equal to $f_{\text{offset}_{\text{max}}}$ minus half of the bandwidth of the measuring filter.

Inside any *Inter RF Bandwidth gaps* with $W_{\text{gap}} < 20$ MHz for a *multi-band TAB connector*, emissions shall not exceed the cumulative sum of the *basic limits* specified at the *Base Station RF Bandwidth edges* on each side of the *Inter RF Bandwidth gap*. The *basic limit* for *Base Station RF Bandwidth edge* is specified in Tables 6.6.4.3.2-1 to 6.6.4.3.2-10 below, where in this case:

- Δf is equal to 2.5MHz plus the separation between the *Base Station RF Bandwidth edge* frequency and the nominal -3dB point of the measuring filter closest to the *Base Station RF Bandwidth edge*.
- f_{offset} is equal to 2.5MHz plus the separation between the *Base Station RF Bandwidth edge* frequency and the centre of the measuring filter.
- $f_{\text{offset}_{\text{max}}}$ is either 12.5 MHz or the offset to the UMTS Tx band edge as defined in section 5.2, whichever is the greater.
- Δf_{max} is equal to $f_{\text{offset}_{\text{max}}}$ minus half of the bandwidth of the measuring filter.

For a *multi-band TAB connector*, the operating band unwanted emission basic limits apply also in a supported operating band without any carrier transmitted, in the case where there are carrier(s) transmitted in another supported operating band. In this case, no cumulative limit is applied in the *inter-band gap* between a supported downlink operating band with carrier(s) transmitted and a supported downlink operating band without any carrier transmitted and

- In case the *inter-band gap* between a downlink band with carrier(s) transmitted and a downlink band without any carrier transmitted is less than 20MHz, $f_{\text{offset}_{\text{max}}}$ shall be the offset to the frequency 10 MHz outside the outermost edges of the two downlink operating bands and the operating band unwanted emission limit of the band where there are carriers transmitted, as defined in the tables of the present subclause, shall apply across both downlink bands.
- In other cases, the operating band unwanted emission limit of the band where there are carriers transmitted, as defined in the tables of the present subclause for the largest frequency offset (Δf_{max}), shall apply from 10 MHz below the lowest frequency, up to 10 MHz above the highest frequency of the downlink operating band without any carrier transmitted.

Inside any sub-block gap for a *TAB connector* operating in non-contiguous spectrum, emissions shall not exceed the cumulative sum of the *basic limits* specified for the adjacent sub blocks on each side of the sub block gap. The *basic limit* for each sub block is specified in Tables 6.6.4.3.2-1 to 6.6.4.3.2-10 below, where in this case:

- Δf is equal to 2.5MHz plus the separation between the sub block edge frequency and the nominal -3 dB point of the measuring filter closest to the sub block edge.
- f_{offset} is equal to 2.5MHz plus the separation between the sub block edge frequency and the centre of the measuring filter.
- $f_{\text{offset}_{\text{max}}}$ is equal to the sub block gap bandwidth minus half of the bandwidth of the measuring filter plus 2.5MHz.
- Δf_{max} is equal to $f_{\text{offset}_{\text{max}}}$ minus half of the bandwidth of the measuring filter.

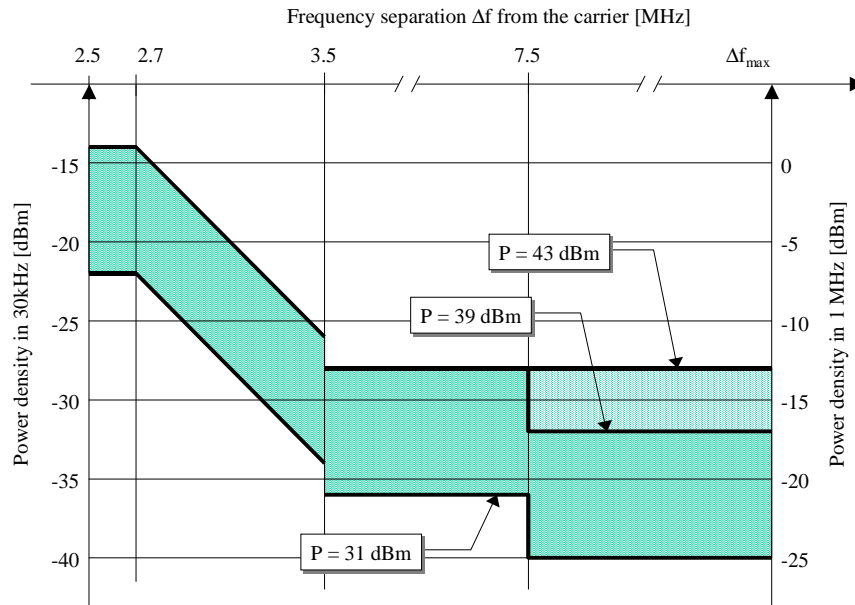

Illustrative diagram of spectrum emission mask

Figure 6.6.4.3.2-1: Spectrum emission mask

Table 6.6.4.3.2-1: Spectrum emission mask values, $P_{\max,c,cell} - 10 \cdot \log_{10}(N_{TXU, \text{counted per cell}}) \geq 43$ dBm for UTRA FDD

Frequency offset of measurement filter - 3 dB point, Δf	Frequency offset of measurement filter centre frequency, f_offset	Basic limit (Note 1, 2)	Measurement bandwidth (Note 4)
$2.5 \text{ MHz} \leq \Delta f < 2.7 \text{ MHz}$	$2.515 \text{ MHz} \leq f_{\text{offset}} < 2.715 \text{ MHz}$	-14 dBm	30 kHz
$2.7 \text{ MHz} \leq \Delta f < 3.5 \text{ MHz}$	$2.715 \text{ MHz} \leq f_{\text{offset}} < 3.515 \text{ MHz}$	$-14 \text{ dBm} - 15 \cdot \left(\frac{f_{\text{offset}}}{\text{MHz}} - 2.715 \right) \text{ dB}$	30 kHz
(Note 3)	$3.515 \text{ MHz} \leq f_{\text{offset}} < 4.0 \text{ MHz}$	-26 dBm	30 kHz
$3.5 \text{ MHz} \leq \Delta f < 7.5 \text{ MHz}$	$4.0 \text{ MHz} \leq f_{\text{offset}} < 8.0 \text{ MHz}$	-13 dBm	1 MHz
$7.5 \text{ MHz} \leq \Delta f \leq \Delta f_{\max}$	$8.0 \text{ MHz} \leq f_{\text{offset}} < f_{\text{offset}_{\max}}$	-13 dBm	1 MHz

NOTE 1: For a TAB connector supporting non-contiguous spectrum operation the basic limit within sub-block gaps within any operating band is calculated as a cumulative sum of contributions from adjacent sub blocks on each side of the sub block gap, where the contribution from the far-end sub-block shall be scaled according to the measurement bandwidth of the near-end sub-block. Exception is $\Delta f \geq 12.5 \text{ MHz}$ from both adjacent sub blocks on each side of the sub-block gap, where the spurious emission basic limit s in clause 6.6.6.5.2.2 and 6.6.6.5.5.3 shall be met.

NOTE 2: For a multi-band TAB connector with Inter RF Bandwidth gap < 20MHz the basic limit within the Inter RF Bandwidth gaps is calculated as a cumulative sum of contributions from adjacent sub-blocks or Base Station RF Bandwidth on each side of the Inter RF Bandwidth gap, where the contribution from the far-end sub-block or Base Station RF Bandwidth shall be scaled according to the measurement bandwidth of the near-end sub-block or Base Station RF Bandwidth.

Table 6.6.4.3.2-2: Spectrum emission mask values, $39 \text{ dBm} \leq P_{\text{max,c,cell}} - 10 \cdot \log_{10}(N_{\text{TXU,countedpercell}}) < 43 \text{ dBm}$ for UTRA FDD bands

Frequency offset of measurement filter -3 dB point, Δf	Frequency offset of measurement filter centre frequency, f_{offset}	<i>Basic limit</i> (Note 1, 2)	Measurement bandwidth (Note 4)
$2.5 \text{ MHz} \leq \Delta f < 2.7 \text{ MHz}$	$2.515 \text{ MHz} \leq f_{\text{offset}} < 2.715 \text{ MHz}$	-14 dBm	30 kHz
$2.7 \text{ MHz} \leq \Delta f < 3.5 \text{ MHz}$	$2.715 \text{ MHz} \leq f_{\text{offset}} < 3.515 \text{ MHz}$	$-14 \text{ dBm} - 15 \cdot \left(\frac{f_{\text{offset}}}{\text{MHz}} - 2.715 \right) \text{ dB}$	30 kHz
(Note 3)	$3.515 \text{ MHz} \leq f_{\text{offset}} < 4.0 \text{ MHz}$	-26 dBm	30 kHz
$3.5 \text{ MHz} \leq \Delta f < 7.5 \text{ MHz}$	$4.0 \text{ MHz} \leq f_{\text{offset}} < 8.0 \text{ MHz}$	-13 dBm	1 MHz
$7.5 \text{ MHz} \leq \Delta f \leq \Delta f_{\text{max}}$	$8.0 \text{ MHz} \leq f_{\text{offset}} < f_{\text{offset}_{\text{max}}}$	$P_{\text{max,c,cell}} - 10 \cdot \log_{10}(N_{\text{TXU,countedpercell}}) - 56 \text{ dB}$	1 MHz
<p>NOTE 1: For a <i>TAB connector</i> supporting non-contiguous spectrum operation the <i>basic limit</i> within sub-block gaps within any operating band is calculated as a cumulative sum of contributions from adjacent sub blocks on each side of the sub block gap, where the contribution from the far-end sub-block shall be scaled according to the measurement bandwidth of the near-end sub-block. Exception is $\Delta f \geq 12.5 \text{ MHz}$ from both adjacent sub blocks on each side of the sub-block gap, where the spurious emission <i>basic limit</i> in clause 6.6.6.5.2.2 and 6.6.6.5.5.3 shall be met.</p> <p>NOTE 2: For a <i>multi-band TAB connector</i> with <i>Inter RF Bandwidth gap</i> $< 20 \text{ MHz}$ the <i>basic limit</i> within the <i>Inter RF Bandwidth gaps</i> is calculated as a cumulative sum of contributions from adjacent sub-blocks or <i>Base Station RF Bandwidth</i> on each side of the <i>Inter RF Bandwidth gap</i>, where the contribution from the far-end sub-block or <i>Base Station RF Bandwidth</i> shall be scaled according to the measurement bandwidth of the near-end sub-block or <i>Base Station RF Bandwidth</i>.</p>			

Table 6.6.4.3.2-3: Spectrum emission mask values, $31 \text{ dBm} \leq P_{\text{max,c,cell}} - 10 \cdot \log_{10}(N_{\text{TXU,countedpercell}}) < 39 \text{ dBm}$ for UTRA FDD bands

Frequency offset of measurement filter - 3 dB point, Δf	Frequency offset of measurement filter centre frequency, f_{offset}	<i>Basic limit</i> (Note 1, 2)	Measurement bandwidth (Note 4)
$2.5 \text{ MHz} \leq \Delta f < 2.7 \text{ MHz}$	$2.515 \text{ MHz} \leq f_{\text{offset}} < 2.715 \text{ MHz}$	$P_{\text{max,c,cell}} - 10 \cdot \log_{10}(N_{\text{TXU,countedpercell}}) - 53 \text{ dB}$	30 kHz
$2.7 \text{ MHz} \leq \Delta f < 3.5 \text{ MHz}$	$2.715 \text{ MHz} \leq f_{\text{offset}} < 3.515 \text{ MHz}$	$P_{\text{max,c,cell}} - 10 \cdot \log_{10}(N_{\text{TXU,countedpercell}}) - 53 \text{ dB} - 15 \cdot \left(\frac{f_{\text{offset}}}{\text{MHz}} - 2.715 \right) \text{ dB}$	30 kHz
(Note 3)	$3.515 \text{ MHz} \leq f_{\text{offset}} < 4.0 \text{ MHz}$	$P_{\text{max,c,cell}} - 10 \cdot \log_{10}(N_{\text{TXU,countedpercell}}) - 65 \text{ dB}$	30 kHz
$3.5 \text{ MHz} \leq \Delta f < 7.5 \text{ MHz}$	$4.0 \text{ MHz} \leq f_{\text{offset}} < 8.0 \text{ MHz}$	$P_{\text{max,c,cell}} - 10 \cdot \log_{10}(N_{\text{TXU,countedpercell}}) - 52 \text{ dB}$	1 MHz
$7.5 \text{ MHz} \leq \Delta f \leq \Delta f_{\text{max}}$	$8.0 \text{ MHz} \leq f_{\text{offset}} < f_{\text{offset}_{\text{max}}}$	$P_{\text{max,c,cell}} - 10 \cdot \log_{10}(N_{\text{TXU,countedpercell}}) - 56 \text{ dB}$	1 MHz
<p>NOTE 1: For a <i>TAB connector</i> supporting non-contiguous spectrum operation the <i>basic limit</i> within sub-block gaps within any operating band is calculated as a cumulative sum of contributions from adjacent sub blocks on each side of the sub block gap, where the contribution from the far-end sub-block shall be scaled according to the measurement bandwidth of the near-end sub-block. Exception is $\Delta f \geq 12.5 \text{ MHz}$ from both adjacent sub blocks on each side of the sub-block gap, where the spurious emission <i>basic limits</i> in clause 6.6.6.5.2.2 and 6.6.6.5.5.3 shall be met.</p> <p>NOTE 2: For a <i>multi-band TAB connector</i> with <i>Inter RF Bandwidth gap</i> $< 20 \text{ MHz}$ the <i>basic limit</i> within the <i>Inter RF Bandwidth gaps</i> is calculated as a cumulative sum of contributions from adjacent sub-blocks or <i>Base Station RF Bandwidth</i> on each side of the <i>Inter RF Bandwidth gap</i>, where the contribution from the far-end sub-block or <i>Base Station RF Bandwidth</i> shall be scaled according to the measurement bandwidth of the near-end sub-block or <i>Base Station RF Bandwidth</i>.</p>			

Table 6.6.4.3.2-4: Spectrum emission mask values, $P_{\max,c,cell} - 10 \cdot \log_{10}(N_{\text{TXU,countedpercell}}) < 31$ dBm for UTRA FDD bands

Frequency offset of measurement filter - 3 dB point, Δf	Frequency offset of measurement filter centre frequency, f_{offset}	Basic limit (Note 1, 2)	Measurement bandwidth (Note 4)
$2.5 \text{ MHz} \leq \Delta f < 2.7 \text{ MHz}$	$2.515 \text{ MHz} \leq f_{\text{offset}} < 2.715 \text{ MHz}$	-22 dBm	30 kHz
$2.7 \leq \Delta f < 3.5 \text{ MHz}$	$2.715 \text{ MHz} \leq f_{\text{offset}} < 3.515 \text{ MHz}$	$-22 \text{ dBm} - 15 \cdot \left(\frac{f_{\text{offset}}}{\text{MHz}} - 2.715 \right) \text{ dB}$	30 kHz
(Note 3)	$3.515 \text{ MHz} \leq f_{\text{offset}} < 4.0 \text{ MHz}$	-34 dBm	30 kHz
$3.5 \text{ MHz} \leq \Delta f < 7.5 \text{ MHz}$	$4.0 \text{ MHz} \leq f_{\text{offset}} < 8.0 \text{ MHz}$	-21 dBm	1 MHz
$7.5 \text{ MHz} \leq \Delta f \leq \Delta f_{\max}$	$8.0 \text{ MHz} \leq f_{\text{offset}} < f_{\text{offset}_{\max}}$	-25 dBm	1 MHz

NOTE 1: For a *TAB connector* supporting non-contiguous spectrum operation the *basic limit* within sub-block gaps within any operating band is calculated as a cumulative sum of contributions from adjacent sub blocks on each side of the sub block gap, where the contribution from the far-end sub-block shall be scaled according to the measurement bandwidth of the near-end sub-block. Exception is $\Delta f \geq 12.5 \text{ MHz}$ from both adjacent sub blocks on each side of the sub-block gap, where the spurious emission *basic limits* in clause 6.6.6.5.2.2 and 6.6.6.5.5.3 shall be met.

NOTE 2: For a *multi-band TAB connector* with *Inter RF Bandwidth gap* $< 20 \text{ MHz}$ the *basic limit* within the *Inter RF Bandwidth gaps* is calculated as a cumulative sum of contributions from adjacent sub-blocks or *Base Station RF Bandwidth* on each side of the *Inter RF Bandwidth gap*, where the contribution from the far-end sub-block or *Base Station RF Bandwidth* shall be scaled according to the measurement bandwidth of the near-end sub-block or *Base Station RF Bandwidth*.

For operation in band II, IV, V, X, XII, XIII, XIV, XXV and XXVI, the additional requirement in Tables 6.6.4.3.2-5 to 6.6.4.3.2-7 apply in addition to the *basic limits* in Tables 6.6.4.3.2-1 to 6.6.4.3.2-4.

Table 6.6.4.3.2-5: Additional spectrum emission basic limits for Bands II, IV, X, XXV

Frequency offset of measurement filter -3dB point, Δf	Frequency offset of measurement filter centre frequency, f_{offset}	Additional basic limit	Measurement bandwidth (Note 4)
$2.5 \text{ MHz} \leq \Delta f < 3.5 \text{ MHz}$	$2.515 \text{ MHz} \leq f_{\text{offset}} < 3.515 \text{ MHz}$	-15 dBm	30 kHz
$3.5 \text{ MHz} \leq \Delta f \leq \Delta f_{\max}$	$4.0 \text{ MHz} \leq f_{\text{offset}} < f_{\text{offset}_{\max}}$	-13 dBm	1 MHz

Table 6.6.4.3.2-6: Additional spectrum emission basic limits for Bands V, XXVI

Frequency offset of measurement filter -3dB point, Δf	Frequency offset of measurement filter centre frequency, f_{offset}	Additional basic limit	Measurement bandwidth (Note 4)
$2.5 \text{ MHz} \leq \Delta f < 3.5 \text{ MHz}$	$2.515 \text{ MHz} \leq f_{\text{offset}} < 3.515 \text{ MHz}$	-15 dBm	30 kHz
$3.5 \text{ MHz} \leq \Delta f \leq \Delta f_{\max}$	$3.55 \text{ MHz} \leq f_{\text{offset}} < f_{\text{offset}_{\max}}$	-13 dBm	100 kHz

Table 6.6.4.3.2-7: Additional spectrum emission basic limits for Bands XII, XIII, XIV

Frequency offset of measurement filter -3dB point, Δf	Frequency offset of measurement filter centre frequency, f_{offset}	Additional basic limit	Measurement bandwidth (Note 4)
$2.5 \text{ MHz} \leq \Delta f < 2.6 \text{ MHz}$	$2.515 \text{ MHz} \leq f_{\text{offset}} < 2.615 \text{ MHz}$	-13 dBm	30 kHz
$2.6 \text{ MHz} \leq \Delta f \leq \Delta f_{\text{max}}$	$2.65 \text{ MHz} \leq f_{\text{offset}} < f_{\text{offset}_{\text{max}}}$	-13 dBm	100 kHz

In certain regions the following requirement may apply for protection of DTT. For a *TAB connector* operating in Band XX, the level of emissions in the band 470-790 MHz, measured in an 8MHz filter bandwidth on centre frequencies F_{filter} according to Table 6.6.4.3.2-8, shall not exceed the maximum emission basic limit $P_{\text{EM},N}$ declared by the manufacturer.

Table 6.6.4.3.2-8: Declared emissions levels for protection of DTT

Filter centre frequency, F_{filter}	Measurement bandwidth	Declared emission basic limit (dBm)
$F_{\text{filter}} = 8 \cdot N + 306 \text{ (MHz)}$; $21 \leq N \leq 60$	8 MHz	$P_{\text{EM},N}$

NOTE: The regional requirement is defined in terms of EIRP (effective isotropic radiated power), which is dependent on both the BS emissions at the antenna connector and the deployment (including antenna gain and feeder loss). The basic limit defined above provides the characteristics of the AAS base station needed to verify compliance with the regional requirement. Compliance with the regional requirement for protection of DTT can be determined using the method outlined in annex D of 3GPP TS 25.104 [2].

In certain regions, the following basic limits may apply to a *TAB connector* operating in Band XXXII within 1452-1492 MHz. The level of unwanted emissions, measured on centre frequencies f_{offset} with filter bandwidth, according to Table 6.6.4.3.2-9, shall neither exceed the maximum emission basic limit $P_{\text{EM},B32,a}$, $P_{\text{EM},B32,b}$ nor $P_{\text{EM},B32,c}$ declared by the manufacturer.

Table 6.6.4.3.2-9: Declared frequency band XXXII unwanted emission within 1452-1492 MHz

Frequency offset of measurement filter centre frequency, f_{offset}	Declared emission basic limit (dBm)	Measurement bandwidth
5 MHz	$P_{\text{EM},B32,a}$	5 MHz
10 MHz	$P_{\text{EM},B32,b}$	5 MHz
$15 \text{ MHz} \leq f_{\text{offset}} \leq f_{\text{offset}_{\text{max}, B32}}$	$P_{\text{EM},B32,c}$	5 MHz
NOTE: $f_{\text{offset}_{\text{max}, B32}}$ denotes the frequency difference between the lower channel carrier frequency and 1454.5 MHz, and the frequency difference between the upper channel carrier frequency and 1489.5 MHz for the set channel position.		

NOTE: The regional requirement, included in CEPT ECC Decision (13)03 [25], is defined in terms of EIRP per antenna, which is dependent on both the BS emissions at the antenna connector and the deployment (including antenna gain and feeder loss). The basic limit defined above provides the characteristics of the base station needed to verify compliance with the regional requirement. The assessment of the EIRP level is described in annex H of 3GPP TS 36.104 [4].

In certain regions, the following basic limit may apply to *TAB connector* operating in Band XXXII within 1452-1492MHz for the protection of services in spectrum adjacent to the frequency range 1452-1492 MHz. The level of emissions, measured on centre frequencies F_{filter} with filter bandwidth according to Table 6.6.4.3.2-10, shall neither exceed the maximum emission basic limit $P_{\text{EM},B32,d}$ nor $P_{\text{EM},B32,e}$ declared by the manufacturer. This requirement applies in the frequency range 1429-1518MHz even though part of the range falls in the spurious domain.

Table 6.6.4.3-10: Frequency band XXXII declared emission outside 1452-1492 MHz

Filter centre frequency, F_{filter}	Declared emission level (dBm)	Measurement bandwidth
$1429.5 \text{ MHz} \leq F_{\text{filter}} \leq 1448.5 \text{ MHz}$	$P_{\text{EM},\text{B32},\text{d}}$	1 MHz
$F_{\text{filter}} = 1450.5 \text{ MHz}$	$P_{\text{EM},\text{B32},\text{e}}$	3 MHz
$F_{\text{filter}} = 1493.5 \text{ MHz}$	$P_{\text{EM},\text{B32},\text{e}}$	3 MHz
$1495.5 \text{ MHz} \leq F_{\text{filter}} \leq 1517.5 \text{ MHz}$	$P_{\text{EM},\text{B32},\text{d}}$	1 MHz

NOTE: The regional requirement, included in CEPT ECC Decision (13)03 [25], is defined in terms of EIRP, which is dependent on both the BS emissions at the antenna connector and the deployment (including antenna gain and feeder loss). The basic limit defined above provides the characteristics of the base station needed to verify compliance with the regional requirement. The assessment of the EIRP level is described in annex H of 3GPP TS 36.104 [4].

Notes for the tables in this subclause:

NOTE 3: This frequency range ensures that the range of values of f_{offset} is continuous.

NOTE 4: As a general rule, the resolution bandwidth of the measuring equipment should be equal to the measurement bandwidth. However, to improve measurement accuracy, sensitivity and efficiency, the resolution bandwidth can be smaller than the measurement bandwidth. When the resolution bandwidth is smaller than the measurement bandwidth, the result should be integrated over the measurement bandwidth in order to obtain the equivalent noise bandwidth of the measurement bandwidth.

6.6.4.3.3 Basic limits for single RAT UTRA TDD 1,28Mcps option operation

The *basic limit* is specified in Tables 6.6.4.3.3-1 to 6.6.4.3.3-3 for the appropriate $P_{\text{Rated},\text{c},\text{sy}}$, where:

The mask defined in Table 6.6.4.3.3-1 to 6.6.4.3.3-3 may be mandatory in certain regions. In other regions this mask may not be applied.

For regions where this clause applies, the basic limit is for a *TAB connector* transmitting on a single RF carrier configured in accordance with the manufacturer's specification. Emissions shall use the *basic limits* specified in table 6.6.4.3.3-1 to 6.6.4.3.3-3 for the appropriate $P_{\text{max},\text{c},\text{cell}}$, in the frequency range from $\Delta f = 0.8 \text{ MHz}$ to Δf_{max} from the carrier frequency, where:

- Δf is the separation between the carrier frequency and the nominal -3dB point of the measuring filter closest to the carrier frequency.
- f_{offset} is the separation between the carrier frequency and the centre frequency of the measuring filter.-
 $f_{\text{offset}_{\text{max}}}$ is either 4 MHz or the offset to the UTRA TDD Tx band edge as defined in subclause 4.6, whichever is the greater.
- Δf_{max} is equal to $f_{\text{offset}_{\text{max}}}$ minus half of the bandwidth of the measurement filter. Inside any *Inter RF bandwidth gaps* with $W_{\text{gap}} < 8 \text{ MHz}$ for *multi-band TAB connector*, emissions shall not exceed the cumulative sum of the *basic limits* specified at the *Base Station RF bandwidth edges* on each side of *Inter RF bandwidth gap*. The *basic limit* for *Base Station RF bandwidth edge* is specified in Tables 6.6.4.3.3-1 to 6.6.4.3.3-3 below, where in this case.
- Δf equal to 0.8MHz plus the separation between the *Base Station RF bandwidth edge* frequency and the nominal -3dB point of the measuring filter closest to the *Base Station RF bandwidth edge*.
- f_{offset} is equal to 0.8MHz plus the separation between the *Base Station RF bandwidth edge* frequency and the centre frequency of the measuring filter.
- $f_{\text{offset}_{\text{max}}}$ is either 4 MHz or the offset to the UTRA TDD Tx band edge as defined in subclause 4.6, whichever is the greater.
- Δf_{max} is equal to $f_{\text{offset}_{\text{max}}}$ minus half of the bandwidth of the measurement filter.

For a multi-carrier *TAB connector*, the definitions above apply to the lower edge of the carrier transmitted at the lowest carrier frequency and the upper edge of the carrier transmitted at the highest carrier frequency within a specified frequency.

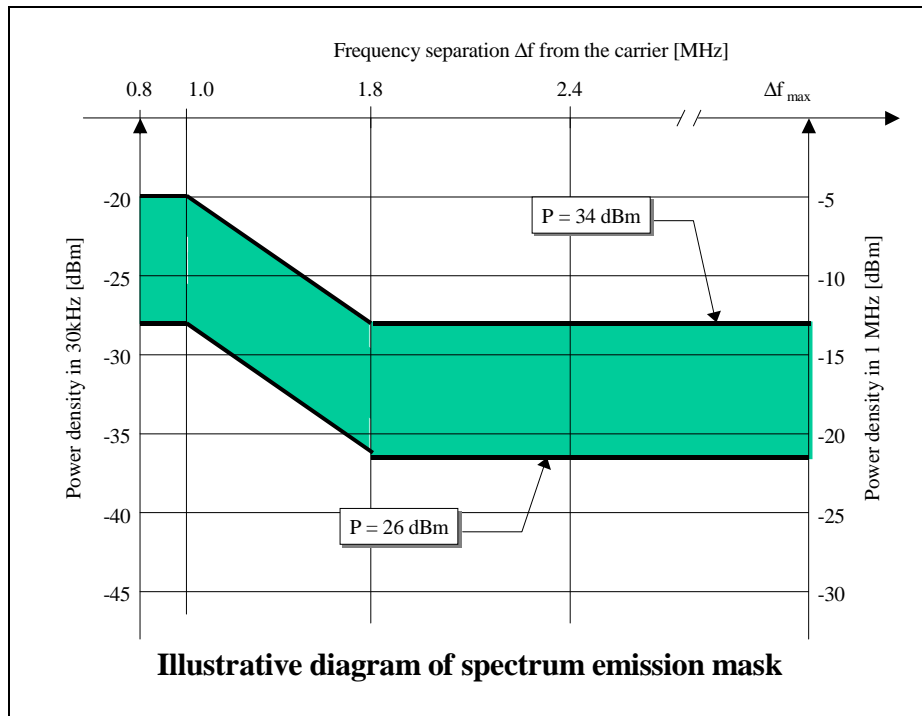

Figure 6.6.4.3.3-1

Table 6.6.4.3.3-1: **Basic Limits** for spectrum emission mask values, $P_{\max,c,cell} - 10 \cdot \log_{10}(N_{TXU, \text{countedpercell}}) \geq 34$ dBm for 1,28 Mcps TDD

Frequency offset of measurement filter centre frequency, f_{offset}	Basic Limit	Measurement bandwidth
$0.8 \text{ MHz} \leq \Delta f < 1.0 \text{ MHz}$	-20 dBm	30 kHz
$1.0 \text{ MHz} \leq \Delta f < 1.8 \text{ MHz}$	$-20 \text{ dBm} - 10 \cdot \left(\frac{f_{\text{offset}}}{\text{MHz}} - 1,015 \right) \text{ dB}$	30 kHz
See note	-28 dBm	30 kHz
$1.8 \text{ MHz} \leq \Delta f \leq \Delta f_{\max}$	-13 dBm	1 MHz

NOTE 1: For a multi-band TAB connector with Inter RF Bandwidth gap less than 8MHz, the basic limit within the Inter RF Bandwidth gap is calculated as a cumulative sum of emissions from the two adjacent carriers on each side of the Inter RF Bandwidth gap.

Table 6.6.4.3.3-2: **Basic Limits** for spectrum emission mask values, $26 \text{ dBm} \leq P_{\max,c,cell} - 10 \cdot \log_{10}(N_{TXU, \text{countedpercell}}) < 34$ dBm for 1,28 Mcps TDD

Frequency offset of measurement filter centre frequency, f_{offset}	Basic Limit	Measurement bandwidth
$0.8 \text{ MHz} \leq \Delta f < 1.0 \text{ MHz}$	$P_{\max,c,cell} - 10 \cdot \log_{10}(N_{TXU, \text{countedpercell}}) - 54 \text{ dB}$	30 kHz
$1.0 \text{ MHz} \leq \Delta f < 1.8 \text{ MHz}$	$P_{\max,c,cell} - 10 \cdot \log_{10}(N_{TXU, \text{countedpercell}}) - 54 \text{ dB} - 10 \cdot \left(\frac{f_{\text{offset}}}{\text{MHz}} - 1,015 \right) \text{ dB}$	30 kHz
See note	$P_{\max,c,cell} - 10 \cdot \log_{10}(N_{TXU, \text{countedpercell}}) - 62 \text{ dB}$	30 kHz
$1.8 \text{ MHz} \leq \Delta f \leq \Delta f_{\max}$	$P_{\max,c,cell} - 10 \cdot \log_{10}(N_{TXU, \text{countedpercell}}) - 47 \text{ dB}$	1 MHz

NOTE 1: For a multi-band TAB connector with Inter RF Bandwidth gap less than 8MHz, the basic limit within the Inter RF Bandwidth gap is calculated as a cumulative sum of emissions from the two adjacent carriers on each side of the Inter RF Bandwidth gap.

Table 6.6.4.3.3-3: Basic Limits for spectrum emission mask values, $P_{\max,c,cell} - 10 \cdot \log_{10}(N_{\text{TXU,countedpercell}}) < 26$ dBm for 1,28 Mcps TDD

Frequency offset of measurement filter centre frequency, f_{offset}	Basic Limit	Measurement bandwidth
$0.8 \text{ MHz} \leq \Delta f < 1.0 \text{ MHz}$	-28 dBm	30 kHz
$1.0 \text{ MHz} \leq \Delta f < 1.8 \text{ MHz}$	$-28 \text{ dBm} - 10 \cdot \left(\frac{f_{\text{offset}}}{\text{MHz}} - 1,015 \right) \text{ dB}$	30 kHz
See note	-36 dBm	30 kHz
$1.8 \text{ MHz} \leq \Delta f \leq \Delta f_{\max}$	-21 dBm	1 MHz
NOTE 1: For a multi-band TAB connector with Inter RF Bandwidth gap less than 8MHz, the basic limit within the Inter RF Bandwidth gap is calculated as a cumulative sum of emissions from the two adjacent carriers on each side of the Inter RF Bandwidth gap.		

NOTE: This frequency range ensures that the range of values of f_{offset} is continuous.

6.6.4.4 Minimum requirement for single RAT E-UTRA operation

There is no spectrum emission mask requirement for a single RAT E-UTRA AAS BS.

6.6.5 Operating band unwanted emission

6.6.5.1 General

Unless otherwise stated, for E-UTRA single band and MSR the operating band unwanted emission limits are defined from 10 MHz below the lowest frequency of each supported *downlink operating band* to the lower Base Station RF Bandwidth edge located at $F_{\text{BW RF,low}}$ and from the upper Base Station RF Bandwidth edge located at $F_{\text{BW RF,high}}$ up to 10 MHz above the highest frequency of each supported *downlink operating band*.

For AAS BS capable of operation in multiple operating bands, using *single band TAB connectors*, the single-band requirements apply to those connectors and the cumulative evaluation of the emission limit in the *Inter RF Bandwidth gap* is not applicable.

The requirements shall apply whatever the type of transmitter considered and for all transmission modes foreseen by the manufacturer's specification.

6.6.5.2 Minimum requirement for MSR operation

6.6.5.2.1 General

The MSR operating band unwanted emission *basic limits* are the same as those specified in 3GPP TS 37.104 [9], subclauses 6.6.2.1, 6.6.2.2 and 6.6.2.4.

The operating band unwanted emission requirements for an MSR AAS BS are that for each *TAB connector TX min cell group* and each applicable *basic limit* as specified in 3GPP TS 37.104 [5], the power summation of the emissions at the *TAB connectors* of the *TAB connector TX min cell group* shall not exceed an AAS BS limit specified as the *basic limit* + $10 \log_{10}(N_{\text{TXU,countedpercell}})$.

NOTE: Conformance to the AAS BS operating band unwanted emission requirement can be demonstrated by meeting at least one of the following criteria as determined by the manufacturer:

- 1) The sum of the emissions power measured on each *TAB connector* in the *TAB connector TX min cell group* shall be less than or equal to the AAS BS limit as defined in this subclause for the respective frequency span.

Or

- 2) The unwanted emissions power at each *TAB connector* shall be less than or equal to the AAS BS limit as defined in this subclause for the respective frequency span, scaled by $-10 \log_{10}(n)$, where n is the number of *TAB connector* in the *TAB connector TX min cell group*.

6.6.5.2.2 Basic limits for Band Categories 1 and 3

For a *TAB connector* operating in Band Category 1 or Band Category 3 the requirement applies outside the *Base Station RF Bandwidth edges*. In addition, for an AAS BS of Wide Area BS class operating in non-contiguous spectrum, it applies inside any sub-block gap. In addition, for an AAS BS of Wide Area BS class operating in multiple bands, the requirements apply inside any *Inter RF Bandwidth gap*.

For an AAS BS of Medium Range BS class operating in Band Category 1 the requirement applies outside the *Base Station RF Bandwidth edges*. In addition, for an AAS BS of Medium Range BS class operating in non-contiguous spectrum, it applies inside any sub-block gap. In addition, for an AAS BS of Medium Range BS class operating in multiple bands, the requirements apply inside any *Inter RF Bandwidth gap*.

For an AAS BS of Local Area BS class operating in Band Category 1 the requirement applies outside the *Base Station RF Bandwidth edges*. In addition, for an AAS BS of Local Area BS class operating in non-contiguous spectrum, it applies inside any sub-block gap. In addition, for an AAS BS Local Area BS class operating in multiple bands, the requirements apply inside any *Inter RF Bandwidth gap*.

Outside the *Base Station RF Bandwidth edges*, emissions shall not exceed the *basic limits* specified in Tables 6.6.5.2.2-1 to 6.6.5.2.2-4 below, where:

- Δf is the separation between the *Base Station RF Bandwidth edge* frequency and the nominal -3 dB point of the measuring filter closest to the carrier frequency.
- f_{offset} is the separation between the *Base Station RF Bandwidth edge* frequency and the centre of the measuring filter.
- $f_{\text{offset}_{\text{max}}}$ is the offset to the frequency 10 MHz outside the downlink operating band.
- Δf_{max} is equal to $f_{\text{offset}_{\text{max}}}$ minus half of the bandwidth of the measuring filter.

For a *multi-band TAB connector*, inside any *Inter RF Bandwidth gaps* with $W_{\text{gap}} < 20$ MHz, emissions shall not exceed the cumulative sum of the *basic limits* specified at the *Base Station RF Bandwidth edges* on each side of the *Inter-RF Bandwidth gap*. The *basic limit* for *Base Station RF Bandwidth edge* is specified in Table 6.6.5.2.2-1 to 6.6.5.2.2-4 below, where in this case:

- Δf is the separation between the *Base Station RF Bandwidth edge* frequency and the nominal -3 dB point of the measuring filter closest to the carrier frequency.
- f_{offset} is the separation between the *Base Station RF Bandwidth edge* frequency and the centre of the measuring filter.
- $f_{\text{offset}_{\text{max}}}$ is equal to the inter *Base Station RF Bandwidth gap* minus half of the bandwidth of the measuring filter.
- Δf_{max} is equal to $f_{\text{offset}_{\text{max}}}$ minus half of the bandwidth of the measuring filter.

For a *multi-band TAB connector*, the operating band unwanted emission limits apply also in a supported operating band without any carriers transmitted, in the case where there are carriers transmitted in another operating band. In this case where there is no carrier transmitted in an operating band, no cumulative limits are applied in the *inter-band gap* between a supported downlink band with carrier(s) transmitted and a supported downlink band without any carrier transmitted and

- In case the *Inter RF Bandwidth gap* between a supported downlink band with carrier(s) transmitted and a supported downlink band without any carrier transmitted is less than 20MHz, $f_{\text{offset}_{\text{max}}}$ shall be the offset to the frequency 10 MHz outside the outermost edges of the two supported downlink operating bands and the operating band unwanted emission limit of the band where there are carriers transmitted, as defined in the tables of the present subclause, shall apply across both supported downlink bands.
- In other cases, the operating band unwanted emission limit of the band where there are carriers transmitted, as defined in the tables of the present subclause for the largest frequency offset (Δf_{max}), shall apply from 10 MHz below the lowest frequency, up to 10 MHz above the highest frequency of the supported downlink operating band without any carrier transmitted.

Inside any sub-block gap for a *TAB connector* operating in non-contiguous spectrum, emissions shall not exceed the cumulative sum of the *basic limits* specified for the adjacent sub blocks on each side of the sub block gap. The *basic limit* for each sub block is specified in Tables 6.6.5.2.2-1 to 6.6.5.2.2-4 below, where in this case:

- Δf is the separation between the sub block edge frequency and the nominal -3 dB point of the measuring filter closest to the sub block edge.
- f_{offset} is the separation between the sub block edge frequency and the centre of the measuring filter.
- $f_{\text{offset}_{\text{max}}}$ is equal to the sub block gap bandwidth minus half of the bandwidth of the measuring filter.
- Δf_{max} is equal to $f_{\text{offset}_{\text{max}}}$ minus half of the bandwidth of the measuring filter.

Table 6.6.5.2.2-1: Wide Area operating band unwanted emission mask (UEM) for BC1 and BC3

Frequency offset of measurement filter -3dB point, Δf	Frequency offset of measurement filter centre frequency, f_{offset}	Basic Limit (Note 1, 2)	Measurement bandwidth (Note 4)
$0 \text{ MHz} \leq \Delta f < 0.2 \text{ MHz}$	$0.015 \text{ MHz} \leq f_{\text{offset}} < 0.215 \text{ MHz}$	-14 dBm	30 kHz
$0.2 \text{ MHz} \leq \Delta f < 1 \text{ MHz}$	$0.215 \text{ MHz} \leq f_{\text{offset}} < 1.015 \text{ MHz}$	$-14 \text{ dBm} - 15 \cdot \left(\frac{f_{\text{offset}}}{\text{MHz}} - 0.215 \right) \text{ dB}$	30 kHz
(Note 3)	$1.015 \text{ MHz} \leq f_{\text{offset}} < 1.5 \text{ MHz}$	-26 dBm	30 kHz
$1 \text{ MHz} \leq \Delta f \leq \min(\Delta f_{\text{max}}, 10 \text{ MHz})$	$1.5 \text{ MHz} \leq f_{\text{offset}} < \min(f_{\text{offset}_{\text{max}}}, 10.5 \text{ MHz})$	-13 dBm	1 MHz
$10 \text{ MHz} \leq \Delta f \leq \Delta f_{\text{max}}$	$10.5 \text{ MHz} \leq f_{\text{offset}} < f_{\text{offset}_{\text{max}}}$	-15 dBm (Note 5)	1 MHz
<p>NOTE 1: For MSR <i>TAB connector</i> supporting non-contiguous spectrum operation within any operating band the <i>basic limit</i> within sub-block gaps is calculated as a cumulative sum of contributions from adjacent sub-blocks on each side of the sub-block gap, where the contribution from the far-end sub-block shall be scaled according to the measurement bandwidth of the near-end sub-block. Exception is $\Delta f \geq 10 \text{ MHz}$ from both adjacent sub-blocks on each side of the sub-block gap, where the <i>basic limit</i> within sub-block gaps shall be -15dBm/MHz.</p> <p>NOTE2: For MSR <i>multi-band TAB connector</i> with <i>Inter RF Bandwidth gap</i> < 20MHz the <i>basic limit</i> within the <i>Inter RF Bandwidth gaps</i> is calculated as a cumulative sum of contributions from adjacent sub-blocks or <i>Base Station RF Bandwidth</i> on each side of the <i>Inter RF Bandwidth gap</i>, where the contribution from the far-end sub-block or RF Bandwidth shall be scaled according to the measurement bandwidth of the near-end sub-block or RF Bandwidth.</p>			

**Table 6.6.5.2.2-2: Medium Range BS operating band unwanted emission mask (UEM) for BC1, 31 <
 $P_{\max,c,cell} - 10 \cdot \log_{10}(N_{TXU, \text{countedpercell}}) \leq 38 \text{ dBm}$**

Frequency offset of measurement filter -3dB point, Δf	Frequency offset of measurement filter centre frequency, f_{offset}	Basic Limit (Note 1, 2)	Measurement bandwidth (Note 4)
$0 \text{ MHz} \leq \Delta f < 0.6 \text{ MHz}$	$0.015 \text{ MHz} \leq f_{\text{offset}} < 0.615 \text{ MHz}$	$P_{\max,c,cell} - 10 \cdot \log_{10}(N_{TXU, \text{countedpercell}}) - 58 \text{ dB} - \frac{7}{5} \left(\frac{f_{\text{offset}}}{\text{MHz}} - 0.015 \right) \text{ dB}$	30 kHz
$0.6 \text{ MHz} \leq \Delta f < 1 \text{ MHz}$	$0.615 \text{ MHz} \leq f_{\text{offset}} < 1.015 \text{ MHz}$	$P_{\max,c,cell} - 10 \cdot \log_{10}(N_{TXU, \text{countedpercell}}) - 53 \text{ dB} - 15 \left(\frac{f_{\text{offset}}}{\text{MHz}} - 0.215 \right) \text{ dB}$	30 kHz
(Note 3)	$1.015 \text{ MHz} \leq f_{\text{offset}} < 1.5 \text{ MHz}$	$P_{\max,c,cell} - 10 \cdot \log_{10}(N_{TXU, \text{countedpercell}}) - 65 \text{ dB}$	30 kHz
$1 \text{ MHz} \leq \Delta f \leq 2.6 \text{ MHz}$	$1.5 \text{ MHz} \leq f_{\text{offset}} < 3.1 \text{ MHz}$	$P_{\max,c,cell} - 10 \cdot \log_{10}(N_{TXU, \text{countedpercell}}) - 52 \text{ dB}$	1 MHz
$2.6 \text{ MHz} \leq \Delta f \leq 5 \text{ MHz}$	$3.1 \text{ MHz} \leq f_{\text{offset}} < 5.5 \text{ MHz}$	$\min(P_{\max,c,cell} - 10 \cdot \log_{10}(N_{TXU, \text{countedpercell}}) - 52 \text{ dB}, -15 \text{ dBm})$	1 MHz
$5 \text{ MHz} \leq \Delta f \leq \Delta f_{\max}$	$5.5 \text{ MHz} \leq f_{\text{offset}} < f_{\text{offset}_{\max}}$	$P_{\max,c,cell} - 10 \cdot \log_{10}(N_{TXU, \text{countedpercell}}) - 56 \text{ dB}$	1 MHz

NOTE 1: For MSR *TAB connector* supporting non-contiguous spectrum operation within any operating band the *basic limit* within sub-block gaps is calculated as a cumulative sum of contributions from adjacent sub blocks on each side of the sub block gap, where the contribution from the far-end sub-block shall be scaled according to the measurement bandwidth of the near-end sub-block. Exception is $\Delta f \geq 10 \text{ MHz}$ from both adjacent sub-blocks on each side of the sub-block gap, where the *basic limit* within sub-block gaps shall be $(P_{\max,c,cell} - 10 \cdot \log_{10}(N_{TXU, \text{countedpercell}}) - 56 \text{ dB}) / \text{MHz}$.

NOTE 2: For MSR multi-band *TAB connector* with *Inter RF Bandwidth gap* < 20MHz the *basic limit* within the *Inter RF Bandwidth gaps* is calculated as a cumulative sum of contributions from adjacent sub-blocks or *Base Station RF Bandwidth* on each side of the *Inter RF Bandwidth gap*, where the contribution from the far-end sub-block or *Base Station RF Bandwidth* shall be scaled according to the measurement bandwidth of the near-end sub-block or *Base Station RF Bandwidth*.

**Table 6.6.5.2.2-3: Medium Range BS operating band unwanted emission mask (UEM) for BC1,
 $P_{\max,c,cell} - 10 \cdot \log_{10}(N_{TXU, \text{countedpercell}}) \leq 31 \text{ dBm}$**

Frequency offset of measurement filter -3dB point, Δf	Frequency offset of measurement filter centre frequency, f_{offset}	Basic Limit (Note 1, 2)	Measurement bandwidth (Note 4)
$0 \text{ MHz} \leq \Delta f < 0.6 \text{ MHz}$	$0.015 \text{ MHz} \leq f_{\text{offset}} < 0.615 \text{ MHz}$	$-27 \text{ dBm} - \frac{5}{3} \left(\frac{f_{\text{offset}}}{\text{MHz}} - 0.015 \right) \text{ dB}$	30 kHz
$0.6 \text{ MHz} \leq \Delta f < 1 \text{ MHz}$	$0.615 \text{ MHz} \leq f_{\text{offset}} < 1.015 \text{ MHz}$	$-22 \text{ dBm} - 15 \cdot \left(\frac{f_{\text{offset}}}{\text{MHz}} - 0.215 \right) \text{ dB}$	30 kHz
(Note 3)	$1.015 \text{ MHz} \leq f_{\text{offset}} < 1.5 \text{ MHz}$	-34 dBm	30 kHz
$1 \text{ MHz} \leq \Delta f \leq 5 \text{ MHz}$	$1.5 \text{ MHz} \leq f_{\text{offset}} < 5.5 \text{ MHz}$	-21 dBm	1 MHz
$5 \text{ MHz} \leq \Delta f \leq \Delta f_{\max}$	$5.5 \text{ MHz} \leq f_{\text{offset}} < f_{\text{offset}_{\max}}$	-25 dBm	1 MHz

NOTE 1: For MSR *TAB connector* supporting non-contiguous spectrum operation within any operating band the *basic limit* within sub-block gaps is calculated as a cumulative sum of contributions from adjacent sub blocks on each side of the sub block gap, where the contribution from the far-end sub-block shall be scaled according to the measurement bandwidth of the near-end sub-block. Exception is $\Delta f \geq 10 \text{ MHz}$ from both adjacent sub-blocks on each side of the sub-block gap, where the *basic limit* within sub-block gaps shall be -25 dBm/MHz.

NOTE 2: For MSR multi-band *TAB connector* with *Inter RF Bandwidth gap* < 20MHz the *basic limit* within the *Inter RF Bandwidth gaps* is calculated as a cumulative sum of contributions from adjacent sub-blocks or *Base Station RF Bandwidth* on each side of the *Inter RF Bandwidth gap*, where the contribution from the far-end sub-block or *Base Station RF Bandwidth* shall be scaled according to the measurement bandwidth of the near-end sub-block or *Base Station RF Bandwidth*.

Table 6.6.5.2.2-4: Local Area operating band unwanted emission mask (UEM) for BC1

Frequency offset of measurement filter -3dB point, Δf	Frequency offset of measurement filter centre frequency, f_{offset}	Basic Limit (Note 1, 2)	Measurement bandwidth (Note 4)
$0 \text{ MHz} \leq \Delta f < 5 \text{ MHz}$	$0.05 \text{ MHz} \leq f_{\text{offset}} < 5.05 \text{ MHz}$	$-30 \text{ dBm} - \frac{7}{5} \left(\frac{f_{\text{offset}}}{\text{MHz}} - 0.05 \right) \text{ dB}$	100 kHz
$5 \text{ MHz} \leq \Delta f < \min(10 \text{ MHz}, \Delta f_{\text{max}})$	$5.05 \text{ MHz} \leq f_{\text{offset}} < \min(10.05 \text{ MHz}, f_{\text{offset}_{\text{max}}})$	-37 dBm	100 kHz
$10 \text{ MHz} \leq \Delta f \leq \Delta f_{\text{max}}$	$10.05 \text{ MHz} \leq f_{\text{offset}} < f_{\text{offset}_{\text{max}}}$	-37 dBm (Note 5)	100 kHz
NOTE 1: For MSR <i>TAB connector</i> supporting non-contiguous spectrum operation within any operating band the <i>basic limit</i> within sub-block gaps is calculated as a cumulative sum of contributions from adjacent sub blocks on each side of the sub block gap. Exception is $\Delta f \geq 10 \text{ MHz}$ from both adjacent sub blocks on each side of the sub-block gap, where the <i>basic limit</i> within sub-block gaps shall be -37dBm/100 kHz.			
NOTE 2: For MSR <i>multi-band TAB connector</i> with <i>Inter RF Bandwidth gap</i> < 20MHz the <i>basic limit</i> within the <i>Inter RF Bandwidth gaps</i> is calculated as a cumulative sum of contributions from adjacent sub-blocks or <i>Base Station RF Bandwidth</i> on each side of the <i>Inter RF Bandwidth gap</i> .			

NOTE 3: This frequency range ensures that the range of values of f_{offset} is continuous.

NOTE 4: As a general rule for the requirements in the present subclause, the resolution bandwidth of the measuring equipment should be equal to the measurement bandwidth. However, to improve measurement accuracy, sensitivity and efficiency, the resolution bandwidth may be smaller than the measurement bandwidth. When the resolution bandwidth is smaller than the measurement bandwidth, the result should be integrated over the measurement bandwidth in order to obtain the equivalent noise bandwidth of the measurement bandwidth.

NOTE 5: The requirement is not applicable when $\Delta f_{\text{max}} < 10 \text{ MHz}$.

6.6.5.2.3 Basic limit for Band Category 2

For a *TAB connector* operating in Band Category 2 the requirement applies outside the *Base Station RF Bandwidth edges*. In addition, for a *TAB connector* operating in non-contiguous spectrum, it applies inside any sub-block gap.

Outside the *Base Station RF Bandwidth edges*, emissions shall not exceed the *basic limits* specified in Tables 6.6.5.2.3-1 to 6.6.5.2.3-8 below, where:

- Δf is the separation between the *Base Station RF Bandwidth edge* frequency and the nominal -3dB point of the measuring filter closest to the carrier frequency.
- f_{offset} is the separation between the *Base Station RF Bandwidth edge* frequency and the centre of the measuring filter.
- $f_{\text{offset}_{\text{max}}}$ is the offset to the frequency 10 MHz outside the downlink operating band.
- Δf_{max} is equal to $f_{\text{offset}_{\text{max}}}$ minus half of the bandwidth of the measuring filter.

For a *multi-band TAB connector*, inside any *Inter-RF Bandwidth gaps* with $W_{\text{gap}} < 20 \text{ MHz}$, emissions shall not exceed the cumulative sum of the *basic limits* specified at the *Base Station RF Bandwidth edges* on each side of the *Inter-RF Bandwidth gap*. The *basic limit* for *Base Station RF Bandwidth edge* is specified in Table 6.6.5.2.3-1 to 6.6.5.2.3-8 below, where in this case:

- Δf is the separation between the *Base Station RF Bandwidth edge* frequency and the nominal -3 dB point of the measuring filter closest to the carrier frequency.
- f_{offset} is the separation between the *Base Station RF Bandwidth edge* frequency and the centre of the measuring filter.
- $f_{\text{offset}_{\text{max}}}$ is equal to the *Inter RF Bandwidth gap* minus half of the bandwidth of the measuring filter.
- Δf_{max} is equal to $f_{\text{offset}_{\text{max}}}$ minus half of the bandwidth of the measuring filter.

For a *multi-band TAB connector* and where there is no carrier transmitted in an operating band, no cumulative limits are applied in the *inter-band gap* between a supported downlink band with carrier(s) transmitted and a supported downlink band without any carrier transmitted and

- In case the *inter-band gap* between a supported downlink band with carrier(s) transmitted and a supported downlink band without any carrier transmitted less than is 20MHz, $f_{\text{offset}_{\text{max}}}$ shall be the offset to the frequency 10 MHz outside the outermost edges of the two supported downlink operating bands and the operating band unwanted emission limit of the band where there are carriers transmitted, as defined in the tables of the present subclause, shall apply across both supported downlink bands.
- In other cases, the operating band unwanted emission limit of the band where there are carriers transmitted, as defined in the tables of the present subclause for the largest frequency offset (Δf_{max}), shall apply from 10 MHz below the lowest frequency, up to 10 MHz above the highest frequency of the supported downlink operating band without any carrier transmitted.

Inside any sub-block gap for a *TAB connector* operating in non-contiguous spectrum, emissions shall not exceed the cumulative sum of the *basic limit* specified for the adjacent sub blocks on each side of the sub block gap. The *basic limit* for each sub block is specified in Tables 6.6.5.2.3-1 to 6.6.5.2.3-8 below, where in this case:

- Δf is the separation between the sub block edge frequency and the nominal -3 dB point of the measuring filter closest to the sub block edge.
- f_{offset} is the separation between the sub block edge frequency and the centre of the measuring filter.
- $f_{\text{offset}_{\text{max}}}$ is equal to the sub block gap bandwidth minus half of the bandwidth of the measuring filter.
- Δf_{max} is equal to $f_{\text{offset}_{\text{max}}}$ minus half of the bandwidth of the measuring filter.

Table 6.6.5.2.3-1: Wide Area operating band unwanted emission mask (UEM) for BC2

Frequency offset of measurement filter -3dB point, Δf	Frequency offset of measurement filter centre frequency, f_{offset}	Basic Limit (Note 2, 3)	Measurement bandwidth (Note 10)
$0 \text{ MHz} \leq \Delta f < 0.2 \text{ MHz}$ (Note 1)	$0.015 \text{ MHz} \leq f_{\text{offset}} < 0.215 \text{ MHz}$	-14 dBm	30 kHz
$0.2 \text{ MHz} \leq \Delta f < 1 \text{ MHz}$	$0.215 \text{ MHz} \leq f_{\text{offset}} < 1.015 \text{ MHz}$	$-14 \text{ dBm} - 15 \cdot \left(\frac{f_{\text{offset}}}{\text{MHz}} - 0.215 \right) \text{ dB}$	30 kHz
(Note 9)	$1.015 \text{ MHz} \leq f_{\text{offset}} < 1.5 \text{ MHz}$	-26 dBm	30 kHz
$1 \text{ MHz} \leq \Delta f \leq \min(\Delta f_{\text{max}}, 10 \text{ MHz})$	$1.5 \text{ MHz} \leq f_{\text{offset}} < \min(f_{\text{offset}_{\text{max}}}, 10.5 \text{ MHz})$	-13 dBm	1 MHz
$10 \text{ MHz} \leq \Delta f \leq \Delta f_{\text{max}}$	$10.5 \text{ MHz} \leq f_{\text{offset}} < f_{\text{offset}_{\text{max}}}$	-15 dBm (Note 11)	1 MHz
NOTE 1: For operation with an E-UTRA 1.4 or 3 MHz carrier adjacent to the <i>Base Station RF Bandwidth edge</i> , the limits in Table 6.6.5.2.3-2 apply for $0 \text{ MHz} \leq \Delta f < 0.15 \text{ MHz}$.			
NOTE 2: For MSR <i>TAB connector</i> supporting non-contiguous spectrum operation within any operating band the <i>basic limit</i> within sub-block gaps is calculated as a cumulative sum of contributions from adjacent sub-blocks on each side of the sub-block gap, where the contribution from the far-end sub-block shall be scaled according to the measurement bandwidth of the near-end sub-block. Exception is $\Delta f \geq 10 \text{ MHz}$ from both adjacent sub-blocks on each side of the sub-block gap, where the <i>basic limit</i> within sub-block gaps shall be -15dBm/MHz.			
NOTE 3: For a MSR <i>multi-band TAB connector</i> with <i>Inter RF Bandwidth gap</i> < 20MHz operation the <i>basic limit</i> within the <i>Inter RF Bandwidth gaps</i> is calculated as a cumulative sum of contributions from adjacent sub-blocks or <i>Base Station RF Bandwidth</i> on each side of the <i>Inter RF Bandwidth gap</i> , where the contribution from the far-end sub-block or <i>Base Station RF Bandwidth</i> shall be scaled according to the measurement bandwidth of the near-end sub-block or <i>Base Station RF Bandwidth</i> .			

Table 6.6.5.2.3-2: Wide Area operating band unwanted emission limits for operation in BC2 with E-UTRA 1.4 or 3 MHz carriers adjacent to the Base Station RF Bandwidth edge

Frequency offset of measurement filter -3dB point, Δf	Frequency offset of measurement filter centre frequency, f_{offset}	Basic Limit (Note 5, 6)	Measurement bandwidth (Note 10)
$0 \text{ MHz} \leq \Delta f < 0.05 \text{ MHz}$	$0.015 \text{ MHz} \leq f_{\text{offset}} < 0.065 \text{ MHz}$	$\text{Max}(5\text{dBm} - 60 \cdot \left(\frac{f_{\text{offset}}}{\text{MHz}} - 0.015 \right) \text{dB} + X_d - 14\text{dBm})$	30 kHz
$0.05 \text{ MHz} \leq \Delta f < 0.15 \text{ MHz}$	$0.065 \text{ MHz} \leq f_{\text{offset}} < 0.165 \text{ MHz}$	$\text{Max}(2\text{dBm} - 160 \cdot \left(\frac{f_{\text{offset}}}{\text{MHz}} - 0.065 \right) \text{dB} + X_d - 14\text{dBm})$	30 kHz

NOTE 4: The limits in this table only apply for operation with an E-UTRA 1.4 or 3 MHz carrier adjacent to the *Base Station RF Bandwidth edge*.

NOTE 5: For MSR *TAB connector* supporting non-contiguous spectrum operation within any operating band the *basic limit* within sub-block gaps is calculated as a cumulative sum of contributions from adjacent sub blocks on each side of the sub block gap.

NOTE 6: For a MSR *multi-band TAB connector* with *Inter RF Bandwidth gap* < 20MHz the *basic limit* within the *Inter RF Bandwidth gaps* is calculated as a cumulative sum of contributions from adjacent sub-blocks or *Base Station RF Bandwidth* on each side of the *Inter RF Bandwidth gap*.

Table 6.6.5.2.3-3: Medium Range BS operating band unwanted emission mask (UEM) for BC2, $31 < P_{\text{max,c,cell}} - 10 \cdot \log_{10}(N_{\text{TXU,countedpercell}}) \leq 38 \text{ dBm}$

Frequency offset of measurement filter -3dB point, Δf	Frequency offset of measurement filter centre frequency, f_{offset}	Basic Limit (Note 2, 3)	Measurement bandwidth (Note 10)
$0 \text{ MHz} \leq \Delta f < 0.6 \text{ MHz}$ (Note 1)	$0.015\text{MHz} \leq f_{\text{offset}} < 0.615\text{MHz}$	$P_{\text{max,c,cell}} - 10 \cdot \log_{10}(N_{\text{TXU,countedpercell}}) - 58\text{dB} - \frac{5}{3} \left(\frac{f_{\text{offset}}}{\text{MHz}} - 0.015 \right) \text{dB}$	30 kHz
$0.6 \text{ MHz} \leq \Delta f < 1 \text{ MHz}$	$0.615\text{MHz} \leq f_{\text{offset}} < 1.015\text{MHz}$	$P_{\text{max,c,cell}} - 10 \cdot \log_{10}(N_{\text{TXU,countedpercell}}) - 53\text{dB} - 15 \left(\frac{f_{\text{offset}}}{\text{MHz}} - 0.215 \right) \text{dB}$	30 kHz
(Note 9)	$1.015\text{MHz} \leq f_{\text{offset}} < 1.5 \text{ MHz}$	$P_{\text{max,c,cell}} - 10 \cdot \log_{10}(N_{\text{TXU,countedpercell}}) - 65 \text{ dB}$	30 kHz
$1 \text{ MHz} \leq \Delta f \leq 2.8 \text{ MHz}$	$1.5 \text{ MHz} \leq f_{\text{offset}} < 3.3 \text{ MHz}$	$P_{\text{max,c,cell}} - 10 \cdot \log_{10}(N_{\text{TXU,countedpercell}}) - 52 \text{ dB}$	1 MHz
$2.8 \text{ MHz} \leq \Delta f \leq 5 \text{ MHz}$	$3.3 \text{ MHz} \leq f_{\text{offset}} < 5.5 \text{ MHz}$	$\min(P_{\text{max,c,cell}} - 10 \cdot \log_{10}(N_{\text{TXU,countedpercell}}) - 52 \text{ dB}, -15\text{dBm})$	1 MHz
$5 \text{ MHz} \leq \Delta f \leq \Delta f_{\text{max}}$	$5.5 \text{ MHz} \leq f_{\text{offset}} < f_{\text{offsetmax}}$	$P_{\text{max,c,cell}} - 10 \cdot \log_{10}(N_{\text{TXU,countedpercell}}) - 56 \text{ dB}$	1 MHz

NOTE 1: For operation with an E-UTRA 1.4 or 3 MHz carrier adjacent to the *Base Station RF Bandwidth edge*, the limits in Table 6.6.5.2.3-5 apply for $0 \text{ MHz} \leq \Delta f < 0.15 \text{ MHz}$.

NOTE 2: For a MSR *TAB connector* supporting non-contiguous spectrum operation within any operating band the *basic limit* within sub-block gaps is calculated as a cumulative sum of contributions from adjacent sub blocks on each side of the sub block gap, where the contribution from the far-end sub-block shall be scaled according to the measurement bandwidth of the near-end sub-block. Exception is $\Delta f \geq 10\text{MHz}$ from both adjacent sub-blocks on each side of the sub-block gap, where the *basic limit* within sub-block gaps shall be $(P_{\text{max,c,cell}} - 10 \cdot \log_{10}(N_{\text{TXU,countedpercell}}) - 56 \text{ dB})/\text{MHz}$.

NOTE 3: For a MSR *multi-band TAB connector* with *Inter RF Bandwidth gap* < 20MHz the *basic limit* within the *Inter RF Bandwidth gaps* is calculated as a cumulative sum of contributions from adjacent sub-blocks or *Base Station RF Bandwidth* on each side of the *Inter RF Bandwidth gap*, where the contribution from the far-end sub-block or *Base Station RF Bandwidth* shall be scaled according to the measurement bandwidth of the near-end sub-block or *Base Station RF Bandwidth*.

**Table 6.6.5.2.3-4: Medium Range BS operating band unwanted emission mask (UEM) for BC2,
 $P_{\max,c,cell} - 10 \cdot \log_{10}(N_{TXU, \text{counted per cell}}) \leq 31$ dBm**

Frequency offset of measurement filter -3dB point, Δf	Frequency offset of measurement filter centre frequency, f_{offset}	Basic Limit (Note 2, 3)	Measurement bandwidth (Note 10)
$0 \text{ MHz} \leq \Delta f < 0.6 \text{ MHz}$ (Note 1)	$0.015 \text{ MHz} \leq f_{\text{offset}} < 0.615 \text{ MHz}$	$-27 \text{ dBm} - \frac{5}{3} \left(\frac{f_{\text{offset}}}{\text{MHz}} - 0.015 \right) \text{ dB}$	30 kHz
$0.6 \text{ MHz} \leq \Delta f < 1 \text{ MHz}$ (Note 9)	$0.615 \text{ MHz} \leq f_{\text{offset}} < 1.015 \text{ MHz}$ $1.015 \text{ MHz} \leq f_{\text{offset}} < 1.5 \text{ MHz}$	$-22 \text{ dBm} - 15 \cdot \left(\frac{f_{\text{offset}}}{\text{MHz}} - 0.215 \right) \text{ dB}$ -34 dBm	30 kHz
$1 \text{ MHz} \leq \Delta f \leq 5 \text{ MHz}$	$1.5 \text{ MHz} \leq f_{\text{offset}} < 5.5 \text{ MHz}$	-21 dBm	1 MHz
$5 \text{ MHz} \leq \Delta f \leq \Delta f_{\max}$	$5.5 \text{ MHz} \leq f_{\text{offset}} < f_{\text{offset}_{\max}}$	-25 dBm	1 MHz
<p>NOTE 1: For operation with an E-UTRA 1.4 or 3 MHz carrier adjacent to the <i>Base Station RF Bandwidth edge</i>, the limits in Table 6.6.2.2-6 apply for $0 \text{ MHz} \leq \Delta f < 0.15 \text{ MHz}$.</p> <p>NOTE 2: For a MSR <i>TAB connector</i> supporting non-contiguous spectrum operation within any operating band the <i>basic limit</i> within sub-block gaps is calculated as a cumulative sum of contributions from adjacent sub blocks on each side of the sub block gap, where the contribution from the far-end sub-block shall be scaled according to the measurement bandwidth of the near-end sub-block. Exception is $\Delta f \geq 10 \text{ MHz}$ from both adjacent sub-blocks on each side of the sub-block gap, where the <i>basic limit</i> within sub-block gaps shall be -25dBm/MHz.</p> <p>NOTE 3: For a MSR <i>multi-band TAB connector</i> with <i>Inter RF Bandwidth gap</i> < 20MHz the <i>basic limit</i> within the <i>Inter RF Bandwidth gaps</i> is calculated as a cumulative sum of contributions from adjacent sub-blocks or <i>Base Station RF Bandwidth</i> on each side of the <i>Inter RF Bandwidth gap</i>, where the contribution from the far-end sub-block or <i>Base Station RF Bandwidth</i> shall be scaled according to the measurement bandwidth of the near-end sub-block or <i>Base Station RF Bandwidth</i>.</p>			

Table 6.6.5.2.3-5: Medium Range operating band unwanted emission limits for operation in BC2 E-UTRA 1.4 or 3 MHz carriers adjacent to the *Base Station RF Bandwidth edge*, $31 < P_{\max,c,cell} - 10 \cdot \log_{10}(N_{TXU, \text{counted per cell}}) \leq 38$ dBm

Frequency offset of measurement filter -3dB point, Δf	Frequency offset of measurement filter centre frequency, f_{offset}	Basic Limit (Note 5, 6)	Measurement bandwidth (Note 10)
$0 \text{ MHz} \leq \Delta f < 0.05 \text{ MHz}$	$0.015 \text{ MHz} \leq f_{\text{offset}} < 0.065 \text{ MHz}$	$P_{\max,c,cell} - 10 \cdot \log_{10}(N_{TXU, \text{counted per cell}}) - 38 \text{ dB} - 60 \left(\frac{f_{\text{offset}}}{\text{MHz}} - 0.015 \right) \text{ dB}$	30 kHz
$0.05 \text{ MHz} \leq \Delta f < 0.15 \text{ MHz}$	$0.065 \text{ MHz} \leq f_{\text{offset}} < 0.165 \text{ MHz}$	$P_{\max,c,cell} - 10 \cdot \log_{10}(N_{TXU, \text{counted per cell}}) - 41 \text{ dB} - 160 \left(\frac{f_{\text{offset}}}{\text{MHz}} - 0.065 \right) \text{ dB}$	30 kHz
<p>NOTE 4: The limits in this table only apply for operation with an E-UTRA 1.4 or 3 MHz carrier adjacent to the <i>Base Station RF Bandwidth edge</i>.</p> <p>NOTE 5: For a MSR <i>TAB connector</i> supporting non-contiguous spectrum operation within any operating band the <i>basic limit</i> within sub-block gaps is calculated as a cumulative sum of contributions from adjacent sub blocks on each side of the sub block gap.</p> <p>NOTE 6: For a MSR <i>multi-band TAB connector</i> with <i>Inter RF Bandwidth gap</i> < 20MHz the <i>basic limit</i> within the <i>Inter RF Bandwidth gaps</i> is calculated as a cumulative sum of contributions from adjacent sub-blocks or <i>Base Station RF Bandwidth</i> on each side of the <i>Inter RF Bandwidth gap</i>.</p>			

**Table 6.6.5.2.3-6: Medium Range operating band unwanted emission limits for operation in BC2 E-UTRA 1.4 or 3 MHz carriers adjacent to the *Base Station RF Bandwidth edge*, $P_{\max,c,cell}$
 $10 \cdot \log_{10}(N_{\text{T XU, counted per cell}}) \leq 31$ dBm**

Frequency offset of measurement filter -3dB point, Δf	Frequency offset of measurement filter centre frequency, f_{offset}	Basic Limit (Note 5, 6)	Measurement bandwidth (Note 10)
$0 \text{ MHz} \leq \Delta f < 0.05 \text{ MHz}$	$0.015 \text{ MHz} \leq f_{\text{offset}} < 0.065 \text{ MHz}$	$\text{Max}\left(-7\text{dBm} - 60 \cdot \left(\frac{f_{\text{offset}}}{\text{MHz}} - 0.015\right) \text{dB} + X\text{dB}, -27\text{dBm}\right)$	30 kHz
$0.05 \text{ MHz} \leq \Delta f < 0.15 \text{ MHz}$	$0.065 \text{ MHz} \leq f_{\text{offset}} < 0.165 \text{ MHz}$	$\text{Max}\left(-10\text{dBm} - 160 \cdot \left(\frac{f_{\text{offset}}}{\text{MHz}} - 0.065\right) \text{dB} + X\text{dB}, -27\text{dBm}\right)$	30 kHz

NOTE 4: The limits in this table only apply for operation with an E-UTRA 1.4 or 3 MHz carrier adjacent to the *Base Station RF Bandwidth edge*.

NOTE 5: For a MSR *TAB connector* supporting non-contiguous spectrum operation within any operating band the *basic limit* within sub-block gaps is calculated as a cumulative sum of contributions from adjacent sub blocks on each side of the sub block gap.

NOTE 6: For a MSR *multi-band TAB connector* with *Inter RF Bandwidth gap* < 20MHz the *basic limit* within the *Inter RF Bandwidth gaps* is calculated as a cumulative sum of contributions from adjacent sub-blocks or *Base Station RF Bandwidth* on each side of the *Inter RF Bandwidth gap*.

Table 6.6.5.2.3-7: Local Area operating band unwanted emission mask (UEM) for BC2

Frequency offset of measurement filter -3dB point, Δf	Frequency offset of measurement filter centre frequency, f_{offset}	Basic Limit (Note 2, 3)	Measurement bandwidth (Note 10)
$0 \text{ MHz} \leq \Delta f < 5 \text{ MHz}$ (Note 1)	$0.05 \text{ MHz} \leq f_{\text{offset}} < 5.05 \text{ MHz}$	$-30\text{dBm} - \frac{7}{5} \left(\frac{f_{\text{offset}}}{\text{MHz}} - 0.05 \right) \text{dB}$	100 kHz
$5 \text{ MHz} \leq \Delta f < \min(10 \text{ MHz}, \Delta f_{\max})$	$5.05 \text{ MHz} \leq f_{\text{offset}} < \min(10.05 \text{ MHz}, f_{\text{offset}_{\max}})$	-37 dBm	100 kHz
$10 \text{ MHz} \leq \Delta f \leq \Delta f_{\max}$	$10.05 \text{ MHz} \leq f_{\text{offset}} < f_{\text{offset}_{\max}}$	-37 dBm (Note 11)	100 kHz

NOTE 1: For operation with an E-UTRA 1.4 or 3 MHz carrier adjacent to the *Base Station RF Bandwidth edge*, the limits in Table 6.6.5.2.3-8 apply for $0 \text{ MHz} \leq \Delta f < 0.16 \text{ MHz}$.

NOTE 2: For a MSR *TAB connector* supporting non-contiguous spectrum operation within any operating band the *basic limit* within sub-block gaps is calculated as a cumulative sum of contributions from adjacent sub blocks on each side of the sub block gap. Exception is $\Delta f \geq 10\text{MHz}$ from both adjacent sub blocks on each side of the sub-block gap, where the *basic limit* within sub-block gaps shall be -37dBm/100 kHz.

NOTE 3: For a MSR *multi-band TAB connector* with *Inter RF Bandwidth gap* < 20MHz the *basic limit* within the *Inter RF Bandwidth gaps* is calculated as a cumulative sum of contributions from adjacent sub-blocks or *Base Station RF Bandwidth* on each side of the *Inter RF Bandwidth gap*.

Table 6.6.5.2.3-8: Local Area operating band unwanted emission limits for operation in BC2 with E-UTRA 1.4 or 3 MHz carriers adjacent to the *Base Station RF Bandwidth edge*

Frequency offset of measurement filter -3dB point, Δf	Frequency offset of measurement filter centre frequency, f_{offset}	Basic Limit (Note 5, 6)	Measurement bandwidth (Note 10)
$0 \text{ MHz} \leq \Delta f < 0.05 \text{ MHz}$	$0.015 \text{ MHz} \leq f_{\text{offset}} < 0.065 \text{ MHz}$	$\text{Max}\left(-14\text{dBm}-60\cdot\left(\frac{f_{\text{offset}}}{\text{MHz}}-0.015\right)\text{dB}+\right. \\ \left.+ X\text{dB}-35\text{dBm}\right)$	30 kHz
$0.05 \text{ MHz} \leq \Delta f < 0.16 \text{ MHz}$	$0.065 \text{ MHz} \leq f_{\text{offset}} < 0.175 \text{ MHz}$	$\text{Max}\left(-17\text{dBm}-160\cdot\left(\frac{f_{\text{offset}}}{\text{MHz}}-0.065\right)\text{dB}+\right. \\ \left.+ X\text{dB}-35\text{dBm}\right)$	30 kHz

NOTE 4: The limits in this table only apply for operation with an E-UTRA 1.4 or 3 MHz carrier adjacent to the *Base Station RF Bandwidth edge*.

NOTE 5: For a MSR *TAB connector* supporting non-contiguous spectrum operation within any operating band the *basic limit* within sub-block gaps is calculated as a cumulative sum of contributions from adjacent sub blocks on each side of the sub block gap.

NOTE 6: For a MSR *multi-band TAB connector* with *Inter RF Bandwidth gap* < 20MHz the *basic limit* within the *Inter RF Bandwidth gaps* is calculated as a cumulative sum of contributions from adjacent sub-blocks or *Base Station RF Bandwidth* on each side of the *Inter RF Bandwidth gap*.

The following notes are common to all subclauses in 6.6.5.2.3: NOTE 9: This frequency range ensures that the range of values of f_{offset} is continuous.

NOTE 10: As a general rule for the requirements in the present subclause, the resolution bandwidth of the measuring equipment should be equal to the measurement bandwidth. However, to improve measurement accuracy, sensitivity and efficiency, the resolution bandwidth may be smaller than the measurement bandwidth. When the resolution bandwidth is smaller than the measurement bandwidth, the result should be integrated over the measurement bandwidth in order to obtain the equivalent noise bandwidth of the measurement bandwidth.

NOTE 11: The requirement is not applicable when $\Delta f_{\text{max}} < 10 \text{ MHz}$.

NOTE 12: All limits in Table 6.6.5.2.3-1, Table 6.6.5.2.3-3, Table 6.6.5.2.3-4 and Table 6.6.5.2.3-7 are identical to the corresponding limits for Band Category 1 and 3.

6.6.5.2.4 Additional requirements

The MSR operating band unwanted emission *basic limits* for additional requirements are the same as the *basic limits* specified in 3GPP TS 37.104 [9], subclause 6.6.2.4.

6.6.5.3 Minimum requirement for single RAT UTRA operation

There is no operating band unwanted emission requirement for a single RAT UTRA FDD or single RAT UTRA TDD AAS BS.

6.6.5.4 Minimum requirement for single RAT E-UTRA operation

6.6.5.4.1 General

The single RAT E-UTRA operating band unwanted emission *basic limits* are given in subclauses 6.6.5.4.2, 6.6.5.4.3 and 6.6.5.4.4.

The operating band unwanted emission requirements for AAS BS in *single RAT E-UTRA operation* are that for each *TAB connector TX min cell group* and each applicable *basic limit*, the power sum of the emissions at the *TAB connectors* of the *TAB connector TX min cell group* shall not exceed an AAS limit specified as the *basic limit* + $10\log_{10}(N_{\text{TXU, counted per cell}})$.

NOTE: Conformance to the AAS BS operating band unwanted emission requirement can be demonstrated by meeting at least one of the following criteria as determined by the manufacturer:

- 1) The sum of the emissions power measured on each *TAB connector* in the *TAB connector TX min cell group* shall be less than or equal to the AAS BS limit as defined in this subclause for the respective frequency span.

Or

- 2) The unwanted emissions power at each *TAB connector* shall be less than or equal to the AAS BS limit as defined in this subclause for the respective frequency span, scaled by $-10\log_{10}(n)$, where n is the number of *TAB connectors* in the *TAB connector TX min cell group*.

The requirements shall apply whatever the type of *TAB connector* is considered (single carrier or multi-carrier) and for all transmission modes foreseen by the manufacturer's specification. In addition, for a *TAB connector* operating in non-contiguous spectrum, the requirements apply inside any sub-block gap. In addition, for a *multi-band TAB connector* the requirements apply inside any *Inter RF Bandwidth gap*.

The unwanted emission limits in the part of the downlink operating band that falls in the spurious domain are consistent with ITU-R Recommendation SM.329 [14].

Emissions shall use the *basic limits* specified in the tables below, where:

- Δf is the separation between the channel edge frequency and the nominal -3dB point of the measuring filter closest to the carrier frequency.
- f_{offset} is the separation between the channel edge frequency and the centre of the measuring filter.
- $f_{\text{offset}_{\text{max}}}$ is the offset to the frequency 10 MHz outside the downlink operating band.
- Δf_{max} is equal to $f_{\text{offset}_{\text{max}}}$ minus half of the bandwidth of the measuring filter.

For a *multi-band TAB connector* inside any *Inter RF Bandwidth gaps* with $W_{\text{gap}} < 20$ MHz, emissions shall not exceed the cumulative sum of the *basic limits* specified at the *Base Station RF Bandwidth edges* on each side of the *Inter RF Bandwidth gap*. The *basic limit* for *Base Station RF Bandwidth edge* is specified in the tables subclause 6.6.5.4.2 to 6.6.5.4.7 below, where in this case:

- Δf is the separation between the *Base Station RF Bandwidth edge* frequency and the nominal -3 dB point of the measuring filter closest to the *Base Station RF Bandwidth edge*.
- f_{offset} is the separation between the *Base Station RF Bandwidth edge* frequency and the centre of the measuring filter.
- $f_{\text{offset}_{\text{max}}}$ is equal to the *Inter RF Bandwidth gap* minus half of the bandwidth of the measuring filter.
- Δf_{max} is equal to $f_{\text{offset}_{\text{max}}}$ minus half of the bandwidth of the measuring filter.

For *multi-band TAB connector* where multiple bands are mapped on the same antenna connector, the operating band unwanted emission limits apply also in a supported operating band without any carrier transmitted, in the case where there are carrier(s) transmitted in another supported operating band. In this case, no cumulative limit is applied in the *inter-band gap* between a supported downlink operating band with carrier(s) transmitted and a supported downlink operating band without any carrier transmitted and

- In case the *inter-band gap* between a supported downlink operating band with carrier(s) transmitted and a supported downlink operating band without any carrier transmitted is less than 20MHz, $f_{\text{offset}_{\text{max}}}$ shall be the offset to the frequency 10 MHz outside the outermost edges of the two supported downlink operating bands and the operating band unwanted emission limit of the band where there are carriers transmitted, as defined in the tables of the present subclause, shall apply across both downlink bands.
- In other cases, the operating band unwanted emission limit of the band where there are carriers transmitted, as defined in the tables of the present subclause for the largest frequency offset (Δf_{max}), shall apply from 10 MHz below the lowest frequency, up to 10 MHz above the highest frequency of the supported downlink operating band without any carrier transmitted.

For a multicarrier E-UTRA TAB connector or a *TAB connector* configured for intra-band contiguous or non-contiguous carrier aggregation the definitions above apply to the lower edge of the carrier transmitted at the lowest carrier

frequency and the upper edge of the carrier transmitted at the highest carrier frequency within a specified frequency band.

In addition inside any sub-block gap for a *TAB connector* operating in non-contiguous spectrum, emissions shall not exceed the cumulative sum of the *basic limits* specified for the adjacent sub blocks on each side of the sub block gap. The *basic limit* for each sub block is specified in the tables subclause 6.6.5.4.2 to 6.6.5.4.7 below, where in this case:

- Δf is the separation between the sub block edge frequency and the nominal -3 dB point of the measuring filter closest to the sub block edge.
- f_{offset} is the separation between the sub block edge frequency and the centre of the measuring filter.
- $f_{\text{offset}_{\text{max}}}$ is equal to the sub block gap bandwidth minus half of the bandwidth of the measuring filter.
- Δf_{max} is equal to $f_{\text{offset}_{\text{max}}}$ minus half of the bandwidth of the measuring filter.

For an AAS BS of Wide Area BS class, the requirements of either subclause 6.6.5.4.2 (Category A limits) or subclause 6.6.5.4.3 (Category B limits) shall apply.

For an AAS BS of Local Area BS class, the requirements of subclause 6.6.5.4.4 shall apply (Category A and B).

For an AAS BS of Medium Range BS class, the requirements in subclause 6.6.5.4.5 shall apply (Category A and B).

The application of either Category A or Category B limits shall be the same as for Transmitter spurious emissions (Mandatory Requirements) in subclause 6.6.6.

6.6.5.4.2 Basic limits for Wide Area BS (Category A)

For E-UTRA *TAB connector* operating in Bands 5, 6, 8, 12, 13, 14, 17, 18, 19, 26, 27, 28, 29, 31, 44, 68 the *basic limits* are specified in Tables 6.6.5.4.2-1 to 6.6.5.4.2-3.

Table 6.6.5.4.2-1: Wide Area BS operating band unwanted emission limits for 1.4 MHz channel bandwidth (E-UTRA bands <1GHz) for Category A

Frequency offset of measurement filter -3dB point, Δf	Frequency offset of measurement filter centre frequency, f_{offset}	<i>Basic limit</i> (Note 1, 2)	Measurement bandwidth (Note 5)
$0 \text{ MHz} \leq \Delta f < 1.4 \text{ MHz}$	$0.05 \text{ MHz} \leq f_{\text{offset}} < 1.45 \text{ MHz}$	$-1 \text{ dBm} - \frac{10}{1.4} \cdot \left(\frac{f_{\text{offset}}}{\text{MHz}} - 0.05 \right) \text{ dB}$	100 kHz
$1.4 \text{ MHz} \leq \Delta f < 2.8 \text{ MHz}$	$1.45 \text{ MHz} \leq f_{\text{offset}} < 2.85 \text{ MHz}$	-11 dBm	100 kHz
$2.8 \text{ MHz} \leq \Delta f \leq \Delta f_{\text{max}}$	$2.85 \text{ MHz} \leq f_{\text{offset}} < f_{\text{offset}_{\text{max}}}$	-13 dBm	100 kHz
NOTE 1: For a <i>TAB connector</i> supporting non-contiguous spectrum operation within any operating band, the <i>basic limit</i> within sub-block gaps is calculated as a cumulative sum of contributions from adjacent sub blocks on each side of the sub block gap. Exception is $\Delta f \geq 10 \text{ MHz}$ from both adjacent sub blocks on each side of the sub-block gap, where the <i>basic limit</i> within sub-block gaps shall be -13dBm/100kHz.			
NOTE 2: For a <i>multi-band TAB connector</i> with <i>Inter RF Bandwidth gap</i> < 20MHz the <i>basic limit</i> within the <i>Inter RF Bandwidth gaps</i> is calculated as a cumulative sum of contributions from adjacent sub-blocks or <i>Base Station RF Bandwidth</i> on each side of the <i>Inter RF Bandwidth gap</i> .			

Table 6.6.5.4.2-2: Wide Area BS operating band unwanted emission limits for 3 MHz channel bandwidth (E-UTRA bands <1GHz) for Category A

Frequency offset of measurement filter -3dB point, Δf	Frequency offset of measurement filter centre frequency, f_{offset}	Basic limit (Note 1, 2)	Measurement bandwidth (Note 5)
$0 \text{ MHz} \leq \Delta f < 3 \text{ MHz}$	$0.05 \text{ MHz} \leq f_{\text{offset}} < 3.05 \text{ MHz}$	$-5 \text{ dBm} - \frac{10}{3} \cdot \left(\frac{f_{\text{offset}}}{\text{MHz}} - 0.05 \right) \text{ dB}$	100 kHz
$3 \text{ MHz} \leq \Delta f < 6 \text{ MHz}$	$3.05 \text{ MHz} \leq f_{\text{offset}} < 6.05 \text{ MHz}$	-15 dBm	100 kHz
$6 \text{ MHz} \leq \Delta f \leq \Delta f_{\text{max}}$	$6.05 \text{ MHz} \leq f_{\text{offset}} < f_{\text{offset}_{\text{max}}}$	-13 dBm	100 kHz
<p>NOTE 1: For a <i>TAB connector</i> supporting non-contiguous spectrum operation within any operating band, the <i>basic limit</i> within sub-block gaps is calculated as a cumulative sum of contributions from adjacent sub blocks on each side of the sub block gap. Exception is $\Delta f \geq 10 \text{ MHz}$ from both adjacent sub blocks on each side of the sub-block gap, where the <i>basic limit</i> within sub-block gaps shall be -13dBm/100kHz.</p> <p>NOTE 2: For a <i>multi-band TAB connector</i> with <i>Inter RF Bandwidth gap</i> < 20MHz the <i>basic limit</i> within the <i>Inter RF Bandwidth gaps</i> is calculated as a cumulative sum of contributions from adjacent sub-blocks or <i>Base Station RF Bandwidth</i> on each side of the <i>Inter RF Bandwidth gap</i>.</p>			

Table 6.6.5.4.2-3: Wide Area BS operating band unwanted emission limits for 5, 10, 15 and 20 MHz channel bandwidth (E-UTRA bands <1GHz) for Category A

Frequency offset of measurement filter -3dB point, Δf	Frequency offset of measurement filter centre frequency, f_{offset}	basic limit (Note 1, 2)	Measurement bandwidth (Note 5)
$0 \text{ MHz} \leq \Delta f < 5 \text{ MHz}$	$0.05 \text{ MHz} \leq f_{\text{offset}} < 5.05 \text{ MHz}$	$-7 \text{ dBm} - \frac{7}{5} \cdot \left(\frac{f_{\text{offset}}}{\text{MHz}} - 0.05 \right) \text{ dB}$	100 kHz
$5 \text{ MHz} \leq \Delta f < \min(10 \text{ MHz}, \Delta f_{\text{max}})$	$5.05 \text{ MHz} \leq f_{\text{offset}} < \min(10.05 \text{ MHz}, f_{\text{offset}_{\text{max}}})$	-14 dBm	100 kHz
$10 \text{ MHz} \leq \Delta f \leq \Delta f_{\text{max}}$	$10.05 \text{ MHz} \leq f_{\text{offset}} < f_{\text{offset}_{\text{max}}}$	-13 dBm (Note 7)	100 kHz
<p>NOTE 1: For a <i>TAB connector</i> supporting non-contiguous spectrum operation within any operating band, the <i>basic limit</i> within sub-block gaps is calculated as a cumulative sum of contributions from adjacent sub blocks on each side of the sub block gap. Exception is $\Delta f \geq 10 \text{ MHz}$ from both adjacent sub blocks on each side of the sub-block gap, where the <i>basic limit</i> within sub-block gaps shall be -13dBm/100kHz.</p> <p>NOTE 2: For a <i>multi-band TAB connector</i> with <i>Inter RF Bandwidth gap</i> < 20MHz the <i>basic limit</i> within the <i>Inter RF Bandwidth gaps</i> is calculated as a cumulative sum of contributions from adjacent sub-blocks or <i>Base Station RF Bandwidth</i> on each side of the <i>Inter RF Bandwidth gap</i>.</p>			

For a E-UTRA *TAB connector* operating in Bands 1, 2, 3, 4, 7, 9, 10, 11, 21, 22, 23, 24, 25, 30, 32, 33, 34, 35, 36, 37, 38, 39, 40, 41, 42, 43, 45, 65, 66, emissions shall use the *basic limits* specified in Tables 6.6.5.4.2-4 to 6.6.5.4.2-6:

Table 6.6.5.4.2-4: Wide Area BS operating band unwanted emission limits for 1.4 MHz channel bandwidth (E-UTRA bands >1GHz) for Category A

Frequency offset of measurement filter -3dB point, Δf	Frequency offset of measurement filter centre frequency, f_{offset}	<i>basic limit</i> (Note 1, 2)	Measurement bandwidth (Note 5)
$0 \text{ MHz} \leq \Delta f < 1.4 \text{ MHz}$	$0.05 \text{ MHz} \leq f_{\text{offset}} < 1.45 \text{ MHz}$	$-1\text{dBm} - \frac{10}{1.4} \cdot \left(\frac{f_{\text{offset}}}{\text{MHz}} - 0.05 \right) \text{dB}$	100 kHz
$1.4 \text{ MHz} \leq \Delta f < 2.8 \text{ MHz}$	$1.45 \text{ MHz} \leq f_{\text{offset}} < 2.85 \text{ MHz}$	-11 dBm	100 kHz
$2.8 \text{ MHz} \leq \Delta f \leq \Delta f_{\text{max}}$	$3.3 \text{ MHz} \leq f_{\text{offset}} < f_{\text{offset}_{\text{max}}}$	-13 dBm	1MHz
NOTE 1: For a <i>TAB connector</i> supporting non-contiguous spectrum operation within any operating band, the <i>basic limit</i> within sub-block gaps is calculated as a cumulative sum of contributions from adjacent sub blocks on each side of the sub block gap, where the contribution from the far-end sub-block shall be scaled according to the measurement bandwidth of the near-end sub-block. Exception is $\Delta f \geq 10\text{MHz}$ from both adjacent sub blocks on each side of the sub-block gap, where the <i>basic limit</i> within sub-block gaps shall be -13dBm/1MHz.			
NOTE 2: For a <i>multi-band TAB connector</i> with <i>Inter RF Bandwidth gap</i> < 20MHz the <i>basic limit</i> within the <i>Inter RF Bandwidth gaps</i> is calculated as a cumulative sum of contributions from adjacent sub-blocks or <i>Base Station RF Bandwidth</i> on each side of the <i>Inter RF Bandwidth gap</i> , where the contribution from the far-end sub-block or RF Bandwidth shall be scaled according to the measurement bandwidth of the near-end sub-block or <i>Base Station RF Bandwidth</i> .			

Table 6.6.5.4.2-5: Wide Area BS operating band unwanted emission limits for 3 MHz channel bandwidth (E-UTRA bands >1GHz) for Category A

Frequency offset of measurement filter -3dB point, Δf	Frequency offset of measurement filter centre frequency, f_{offset}	<i>basic limit</i> (Note 1, 2)	Measurement bandwidth (Note 5)
$0 \text{ MHz} \leq \Delta f < 3 \text{ MHz}$	$0.05 \text{ MHz} \leq f_{\text{offset}} < 3.05 \text{ MHz}$	$-5\text{dBm} - \frac{10}{3} \cdot \left(\frac{f_{\text{offset}}}{\text{MHz}} - 0.05 \right) \text{dB}$	100 kHz
$3 \text{ MHz} \leq \Delta f < 6 \text{ MHz}$	$3.05 \text{ MHz} \leq f_{\text{offset}} < 6.05 \text{ MHz}$	-15 dBm	100 kHz
$6 \text{ MHz} \leq \Delta f \leq \Delta f_{\text{max}}$	$6.5 \text{ MHz} \leq f_{\text{offset}} < f_{\text{offset}_{\text{max}}}$	-13 dBm	1MHz
NOTE 1: For a <i>TAB connector</i> supporting non-contiguous spectrum operation within any operating band, the <i>basic limit</i> within sub-block gaps is calculated as a cumulative sum of contributions from adjacent sub blocks on each side of the sub block gap, where the contribution from the far-end sub-block shall be scaled according to the measurement bandwidth of the near-end sub-block. Exception is $\Delta f \geq 10\text{MHz}$ from both adjacent sub blocks on each side of the sub-block gap, where the <i>basic limit</i> within sub-block gaps shall be -13dBm/1MHz.			
NOTE 2: For a <i>multi-band TAB connector</i> with <i>Inter RF Bandwidth gap</i> < 20MHz the <i>basic limit</i> within the <i>Inter RF Bandwidth gaps</i> is calculated as a cumulative sum of contributions from adjacent sub-blocks or <i>Base Station RF Bandwidth</i> on each side of the <i>Inter RF Bandwidth gap</i> , where the contribution from the far-end sub-block or <i>Base Station RF Bandwidth</i> shall be scaled according to the measurement bandwidth of the near-end sub-block or <i>Base Station RF Bandwidth</i> .			

Table 6.6.5.4.2-6: Wide Area BS operating band unwanted emission limits for 5, 10, 15 and 20 MHz channel bandwidth (E-UTRA bands >1GHz) for Category A

Frequency offset of measurement filter -3dB point, Δf	Frequency offset of measurement filter centre frequency, f_{offset}	<i>basic limit</i> (Note 1, 2)	Measurement bandwidth (Note 5)
$0 \text{ MHz} \leq \Delta f < 5 \text{ MHz}$	$0.05 \text{ MHz} \leq f_{\text{offset}} < 5.05 \text{ MHz}$	$-7 \text{ dBm} - \frac{7}{5} \cdot \left(\frac{f_{\text{offset}}}{\text{MHz}} - 0.05 \right) \text{ dB}$	100 kHz
$5 \text{ MHz} \leq \Delta f < \min(10 \text{ MHz}, \Delta f_{\text{max}})$	$5.05 \text{ MHz} \leq f_{\text{offset}} < \min(10.05 \text{ MHz}, f_{\text{offset}_{\text{max}}})$	-14 dBm	100 kHz
$10 \text{ MHz} \leq \Delta f \leq \Delta f_{\text{max}}$	$10.5 \text{ MHz} \leq f_{\text{offset}} < f_{\text{offset}_{\text{max}}}$	-13 dBm (Note 7)	1MHz
<p>NOTE 1: For a <i>TAB connector</i> supporting non-contiguous spectrum operation within any operating band, the <i>basic limit</i> within sub-block gaps is calculated as a cumulative sum of contributions from adjacent sub blocks on each side of the sub block gap, where the contribution from the far-end sub-block shall be scaled according to the measurement bandwidth of the near-end sub-block. Exception is $\Delta f \geq 10\text{MHz}$ from both adjacent sub blocks on each side of the sub-block gap, where the <i>basic limit</i> within sub-block gaps shall be -13dBm/1MHz.</p> <p>NOTE 2: For a <i>multi-band TAB connector</i> with <i>Inter RF Bandwidth gap</i> < 20MHz the <i>basic limit</i> within the <i>Inter RF Bandwidth gaps</i> is calculated as a cumulative sum of contributions from adjacent sub-blocks or <i>Base Station RF Bandwidth</i> on each side of the <i>Inter RF Bandwidth gap</i>, where the contribution from the far-end sub-block or <i>Base Station RF Bandwidth</i> shall be scaled according to the measurement bandwidth of the near-end sub-block or <i>Base Station RF Bandwidth</i>.</p>			

6.6.5.4.3 Basic limits for Wide Area BS (Category B)

6.6.5.4.3.1 General

For Category B Operating band unwanted emissions, there are two options for the limits that may be applied regionally. Either the limits in subclause 6.6.3.2.1 or subclause 6.6.3.2.2 shall be applied.

6.6.5.4.3.2 Category B requirements (Option 1)

For a E-UTRA *TAB connector* operating in Bands 5, 8, 12, 13, 14, 17, 20, 26, 27, 28, 29, 31, 44, 68, 67 emissions shall use the *basic limits* specified in Tables 6.6.5.4.3.2-1 to 6.6.5.4.3.2-3:

Table 6.6.5.4.3.2-1: Wide Area BS operating band unwanted emission limits for 1.4 MHz channel bandwidth (E-UTRA bands <1GHz) for Category B

Frequency offset of measurement filter -3dB point, Δf	Frequency offset of measurement filter centre frequency, f_{offset}	<i>basic limit</i> (Note 1, 2)	Measurement bandwidth (Note 5)
$0 \text{ MHz} \leq \Delta f < 1.4 \text{ MHz}$	$0.05 \text{ MHz} \leq f_{\text{offset}} < 1.45 \text{ MHz}$	$-1 \text{ dBm} - \frac{10}{1.4} \cdot \left(\frac{f_{\text{offset}}}{\text{MHz}} - 0.05 \right) \text{ dB}$	100 kHz
$1.4 \text{ MHz} \leq \Delta f < 2.8 \text{ MHz}$	$1.45 \text{ MHz} \leq f_{\text{offset}} < 2.85 \text{ MHz}$	-11 dBm	100 kHz
$2.8 \text{ MHz} \leq \Delta f \leq \Delta f_{\text{max}}$	$2.85 \text{ MHz} \leq f_{\text{offset}} < f_{\text{offset}_{\text{max}}}$	-16 dBm	100 kHz
<p>NOTE 1: For a <i>TAB connector</i> supporting non-contiguous spectrum operation within any operating band, the <i>basic limit</i> within sub-block gaps is calculated as a cumulative sum of contributions from adjacent sub blocks on each side of the sub block gap. Exception is $\Delta f \geq 10\text{MHz}$ from both adjacent sub blocks on each side of the sub-block gap, where the <i>basic limit</i> within sub-block gaps shall be -16dBm/100kHz.</p> <p>NOTE 2: For a <i>multi-band TAB connector</i> with <i>Inter RF Bandwidth gap</i> < 20MHz the <i>basic limit</i> within the <i>Inter RF Bandwidth gaps</i> is calculated as a cumulative sum of contributions from adjacent sub-blocks or <i>Base Station RF Bandwidth</i> on each side of the <i>Inter RF Bandwidth gap</i>.</p>			

Table 6.6.5.4.3.2-2: Wide Area BS operating band unwanted emission limits for 3 MHz channel bandwidth (E-UTRA bands <1GHz) for Category B

Frequency offset of measurement filter -3dB point, Δf	Frequency offset of measurement filter centre frequency, f_{offset}	<i>basic limit</i> (Note 1, 2)	Measurement bandwidth (Note 5)
$0 \text{ MHz} \leq \Delta f < 3 \text{ MHz}$	$0.05 \text{ MHz} \leq f_{\text{offset}} < 3.05 \text{ MHz}$	$-5 \text{ dBm} - \frac{10}{3} \cdot \left(\frac{f_{\text{offset}}}{\text{MHz}} - 0.05 \right) \text{ dB}$	100 kHz
$3 \text{ MHz} \leq \Delta f < 6 \text{ MHz}$	$3.05 \text{ MHz} \leq f_{\text{offset}} < 6.05 \text{ MHz}$	-15 dBm	100 kHz
$6 \text{ MHz} \leq \Delta f \leq \Delta f_{\text{max}}$	$6.05 \text{ MHz} \leq f_{\text{offset}} < f_{\text{offset}_{\text{max}}}$	-16 dBm	100 kHz
<p>NOTE 1: For a <i>TAB connector</i> supporting non-contiguous spectrum operation within any operating band, the <i>basic limit</i> within sub-block gaps is calculated as a cumulative sum of contributions from adjacent sub blocks on each side of the sub block gap. Exception is $\Delta f \geq 10 \text{ MHz}$ from both adjacent sub blocks on each side of the sub-block gap, where the <i>basic limit</i> within sub-block gaps shall be -16dBm/100kHz.</p> <p>NOTE 2: For a <i>multi-band TAB connector</i> with <i>Inter RF Bandwidth gap</i> < 20MHz the <i>basic limit</i> within the <i>Inter RF Bandwidth gaps</i> is calculated as a cumulative sum of contributions from adjacent sub-blocks or <i>Base Station RF Bandwidth</i> on each side of the <i>Inter RF Bandwidth gap</i>.</p>			

Table 6.6.5.4.3.2-3: Wide Area BS operating band unwanted emission limits for 5, 10, 15 and 20 MHz channel bandwidth (E-UTRA bands <1GHz) for Category B

Frequency offset of measurement filter -3dB point, Δf	Frequency offset of measurement filter centre frequency, f_{offset}	<i>basic limit</i> (Note 1, 2)	Measurement bandwidth (Note 5)
$0 \text{ MHz} \leq \Delta f < 5 \text{ MHz}$	$0.05 \text{ MHz} \leq f_{\text{offset}} < 5.05 \text{ MHz}$	$-7 \text{ dBm} - \frac{7}{5} \cdot \left(\frac{f_{\text{offset}}}{\text{MHz}} - 0.05 \right) \text{ dB}$	100 kHz
$5 \text{ MHz} \leq \Delta f < \min(10 \text{ MHz}, \Delta f_{\text{max}})$	$5.05 \text{ MHz} \leq f_{\text{offset}} < \min(10.05 \text{ MHz}, f_{\text{offset}_{\text{max}}})$	-14 dBm	100 kHz
$10 \text{ MHz} \leq \Delta f \leq \Delta f_{\text{max}}$	$10.05 \text{ MHz} \leq f_{\text{offset}} < f_{\text{offset}_{\text{max}}}$	-16 dBm (Note 7)	100 kHz
<p>NOTE 1: For a <i>TAB connector</i> supporting non-contiguous spectrum operation within any operating band, the <i>basic limit</i> within sub-block gaps is calculated as a cumulative sum of contributions from adjacent sub blocks on each side of the sub block gap. Exception is $\Delta f \geq 10 \text{ MHz}$ from both adjacent sub blocks on each side of the sub-block gap, where the <i>basic limit</i> within sub-block gaps shall be -16dBm/100kHz.</p> <p>NOTE 2: For a <i>multi-band TAB connector</i> with <i>Inter RF Bandwidth gap</i> < 20MHz the <i>basic limit</i> within the <i>Inter RF Bandwidth gaps</i> is calculated as a cumulative sum of contributions from adjacent sub-blocks or <i>Base Station RF Bandwidth</i> on each side of the <i>Inter RF Bandwidth gap</i>.</p>			

For a E-UTRA *TAB connector* operating in Bands 1, 2, 3, 4, 7, 10, 22, 25, 30, 33, 34, 35, 36, 37, 38, 39, 40, 41, 42, 43, 45, 65, 66, emissions shall use the *basic limits* specified in Tables 6.6.5.4.3.2-4 to 6.6.5.4.3.2-6:

Table 6.6.5.4.3.2-4: Wide Area BS operating band unwanted emission limits for 1.4 MHz channel bandwidth (E-UTRA bands >1GHz) for Category B

Frequency offset of measurement filter -3dB point, Δf	Frequency offset of measurement filter centre frequency, f_{offset}	<i>basic limit</i> (Note 1, 2)	Measurement bandwidth (Note 5)
$0 \text{ MHz} \leq \Delta f < 1.4 \text{ MHz}$	$0.05 \text{ MHz} \leq f_{\text{offset}} < 1.45 \text{ MHz}$	$-1\text{dBm} - \frac{10}{1.4} \cdot \left(\frac{f_{\text{offset}}}{\text{MHz}} - 0.05 \right) \text{dB}$	100 kHz
$1.4 \text{ MHz} \leq \Delta f < 2.8 \text{ MHz}$	$1.45 \text{ MHz} \leq f_{\text{offset}} < 2.85 \text{ MHz}$	-11 dBm	100 kHz
$2.8 \text{ MHz} \leq \Delta f \leq \Delta f_{\text{max}}$	$3.3 \text{ MHz} \leq f_{\text{offset}} < f_{\text{offset}_{\text{max}}}$	-15 dBm	1MHz
<p>NOTE 1: For a <i>TAB connector</i> supporting non-contiguous spectrum operation within any operating band, the <i>basic limit</i> within sub-block gaps is calculated as a cumulative sum of contributions from adjacent sub blocks on each side of the sub block gap, where the contribution from the far-end sub-block shall be scaled according to the measurement bandwidth of the near-end sub-block. Exception is $\Delta f \geq 10\text{MHz}$ from both adjacent sub blocks on each side of the sub-block gap, where the <i>basic limit</i> within sub-block gaps shall be -15dBm/1MHz.</p> <p>NOTE 2: For a <i>multi-band TAB connector</i> with <i>Inter RF Bandwidth gap</i> < 20MHz the <i>basic limit</i> within the <i>Inter RF Bandwidth gaps</i> is calculated as a cumulative sum of contributions from adjacent sub-blocks or <i>Base Station RF Bandwidth</i> on each side of the <i>Inter RF Bandwidth gap</i>, where the contribution from the far-end sub-block or <i>Base Station RF Bandwidth</i> shall be scaled according to the measurement bandwidth of the near-end sub-block or <i>Base Station RF Bandwidth</i>.</p>			

Table 6.6.5.4.3.2-5: Wide Area BS operating band unwanted emission limits for 3 MHz channel bandwidth (E-UTRA bands >1GHz) for Category B

Frequency offset of measurement filter -3dB point, Δf	Frequency offset of measurement filter centre frequency, f_{offset}	<i>basic limit</i> (Note 1, 2)	Measurement bandwidth (Note 5)
$0 \text{ MHz} \leq \Delta f < 3 \text{ MHz}$	$0.05 \text{ MHz} \leq f_{\text{offset}} < 3.05 \text{ MHz}$	$-5\text{dBm} - \frac{10}{3} \cdot \left(\frac{f_{\text{offset}}}{\text{MHz}} - 0.05 \right) \text{dB}$	100 kHz
$3 \text{ MHz} \leq \Delta f < 6 \text{ MHz}$	$3.05 \text{ MHz} \leq f_{\text{offset}} < 6.05 \text{ MHz}$	-15 dBm	100 kHz
$6 \text{ MHz} \leq \Delta f \leq \Delta f_{\text{max}}$	$6.5 \text{ MHz} \leq f_{\text{offset}} < f_{\text{offset}_{\text{max}}}$	-15 dBm	1MHz
<p>NOTE 1: For a <i>TAB connector</i> supporting non-contiguous spectrum operation within any operating band, the <i>basic limit</i> within sub-block gaps is calculated as a cumulative sum of contributions from adjacent sub blocks on each side of the sub block gap, where the contribution from the far-end sub-block shall be scaled according to the measurement bandwidth of the near-end sub-block. Exception is $\Delta f \geq 10\text{MHz}$ from both adjacent sub blocks on each side of the sub-block gap, where the <i>basic limit</i> within sub-block gaps shall be -15dBm/1MHz.</p> <p>NOTE 2: For a <i>multi-band TAB connector</i> with <i>Inter RF Bandwidth gap</i> < 20MHz the <i>basic limit</i> within the <i>Inter RF Bandwidth gaps</i> is calculated as a cumulative sum of contributions from adjacent sub-blocks or <i>Base Station RF Bandwidth</i> on each side of the <i>Inter RF Bandwidth gap</i>, where the contribution from the far-end sub-block or <i>Base Station RF Bandwidth</i> shall be scaled according to the measurement bandwidth of the near-end sub-block or <i>Base Station RF Bandwidth</i>.</p>			

Table 6.6.5.4.3.2-6: Wide Area BS operating band unwanted emission limits for 5, 10, 15 and 20 MHz channel bandwidth (E-UTRA bands >1GHz) for Category B

Frequency offset of measurement filter -3dB point, Δf	Frequency offset of measurement filter centre frequency, f_{offset}	<i>basic limit</i> (Note 1, 2)	Measurement bandwidth (Note 5)
$0 \text{ MHz} \leq \Delta f < 5 \text{ MHz}$	$0.05 \text{ MHz} \leq f_{\text{offset}} < 5.05 \text{ MHz}$	$-7 \text{ dBm} - \frac{7}{5} \cdot \left(\frac{f_{\text{offset}}}{\text{MHz}} - 0.05 \right) \text{ dB}$	100 kHz
$5 \text{ MHz} \leq \Delta f < \min(10 \text{ MHz}, \Delta f_{\text{max}})$	$5.05 \text{ MHz} \leq f_{\text{offset}} < \min(10.05 \text{ MHz}, f_{\text{offset}_{\text{max}}})$	-14 dBm	100 kHz
$10 \text{ MHz} \leq \Delta f \leq \Delta f_{\text{max}}$	$10.5 \text{ MHz} \leq f_{\text{offset}} < f_{\text{offset}_{\text{max}}}$	-15 dBm (Note 7)	1MHz
<p>NOTE 1: For a <i>TAB connector</i> supporting non-contiguous spectrum operation within any operating band, the <i>basic limit</i> within sub-block gaps is calculated as a cumulative sum of contributions from adjacent sub blocks on each side of the sub block gap, where the contribution from the far-end sub-block shall be scaled according to the measurement bandwidth of the near-end sub-block. Exception is $\Delta f \geq 10\text{MHz}$ from both adjacent sub blocks on each side of the sub-block gap, where the <i>basic limit</i> within sub-block gaps shall be -15dBm/1MHz.</p> <p>NOTE 2: For a <i>multi-band TAB connector</i> with <i>Inter RF Bandwidth gap</i> < 20MHz the <i>basic limit</i> within the <i>Inter RF Bandwidth gaps</i> is calculated as a cumulative sum of contributions from adjacent sub-blocks or <i>Base Station RF Bandwidth</i> on each side of the <i>Inter RF Bandwidth gap</i>, where the contribution from the far-end sub-block or <i>Base Station RF Bandwidth</i> shall be scaled according to the measurement bandwidth of the near-end sub-block or <i>Base Station RF Bandwidth</i>.</p>			

6.6.5.4.3.3 Category B (Option 2)

The limits in this subclause are intended for Europe and may be applied regionally for a *TAB connector* operating in band 1, 3, 8, 32, 33, 34 or 65.

For a *TAB connector* operating in band 1, 3, 8, 32, 33, 34 or 65, emissions shall use the *basic limits* specified in Table 6.6.5.4.3.3-1 below for 5, 10, 15 and 20 MHz channel bandwidth:

Table 6.6.5.4.3.3-1: Regional Wide Area BS operating band unwanted emission limits in band 1, 3, 8, 32, 33, 34 or 65 for 5, 10, 15 and 20 MHz channel bandwidth for Category B

Frequency offset of measurement filter -3dB point, Δf	Frequency offset of measurement filter centre frequency, f_{offset}	<i>basic limit</i> (Note 1, 2)	Measurement bandwidth (Note 5)
$0 \text{ MHz} \leq \Delta f < 0.2 \text{ MHz}$	$0.015 \text{ MHz} \leq f_{\text{offset}} < 0.215 \text{ MHz}$	-14 dBm	30 kHz
$0.2 \text{ MHz} \leq \Delta f < 1 \text{ MHz}$	$0.215 \text{ MHz} \leq f_{\text{offset}} < 1.015 \text{ MHz}$	$-14 \text{ dBm} - 15 \cdot \left(\frac{f_{\text{offset}}}{\text{MHz}} - 0.215 \right) \text{ dB}$	30 kHz
(Note 6)	$1.015 \text{ MHz} \leq f_{\text{offset}} < 1.5 \text{ MHz}$	-26 dBm	30 kHz
$1 \text{ MHz} \leq \Delta f \leq \min(10 \text{ MHz}, \Delta f_{\text{max}})$	$1.5 \text{ MHz} \leq f_{\text{offset}} < \min(10.5 \text{ MHz}, f_{\text{offset}_{\text{max}}})$	-13 dBm	1 MHz
$10 \text{ MHz} \leq \Delta f \leq \Delta f_{\text{max}}$	$10.5 \text{ MHz} \leq f_{\text{offset}} < f_{\text{offset}_{\text{max}}}$	-15 dBm (Note 7)	1 MHz
<p>NOTE 1: For a <i>TAB connector</i> supporting non-contiguous spectrum operation within any operating band, the <i>basic limit</i> within sub-block gaps is calculated as a cumulative sum of contributions from adjacent sub blocks on each side of the sub block gap, where the contribution from the far-end sub-block shall be scaled according to the measurement bandwidth of the near-end sub-block. Exception is $\Delta f \geq 10 \text{ MHz}$ from both adjacent sub blocks on each side of the sub-block gap, where the <i>basic limit</i> within sub-block gaps shall be -15dBm/1MHz.</p> <p>NOTE 2: For a <i>multi-band TAB connector</i> with <i>Inter RF Bandwidth gap</i> < 20MHz the <i>basic limit</i> within the <i>Inter RF Bandwidth gaps</i> is calculated as a cumulative sum of contributions from adjacent sub-blocks or <i>Base Station RF Bandwidth</i> on each side of the <i>Inter RF Bandwidth gap</i>, where the contribution from the far-end sub-block or <i>Base Station RF Bandwidth</i> shall be scaled according to the measurement bandwidth of the near-end sub-block or <i>Base Station RF Bandwidth</i>.</p>			

For a *TAB connector* operating in band 3 or 8, emissions shall use the *basic limits* specified in Table 6.6.5.4.3.3-2 below for 3 MHz channel bandwidth:

Table 6.6.5.4.3.3-2: Regional Wide Area BS operating band unwanted emission limits in band 3 or 8 for 3 MHz channel bandwidth for Category B

Frequency offset of measurement filter -3dB point, Δf	Frequency offset of measurement filter centre frequency, f_{offset}	<i>basic limit</i> (Note 1, 2)	Measurement bandwidth (Note 5)
$0 \text{ MHz} \leq \Delta f < 0.05 \text{ MHz}$	$0.015 \text{ MHz} \leq f_{\text{offset}} < 0.065 \text{ MHz}$	$5 \text{ dBm} - 60 \cdot \left(\frac{f_{\text{offset}}}{\text{MHz}} - 0.015 \right) \text{ dB}$	30 kHz
$0.05 \text{ MHz} \leq \Delta f < 0.15 \text{ MHz}$	$0.065 \text{ MHz} \leq f_{\text{offset}} < 0.165 \text{ MHz}$	$2 \text{ dBm} - 160 \cdot \left(\frac{f_{\text{offset}}}{\text{MHz}} - 0.065 \right) \text{ dB}$	30 kHz
$0.15 \text{ MHz} \leq \Delta f < 0.2 \text{ MHz}$	$0.165 \text{ MHz} \leq f_{\text{offset}} < 0.215 \text{ MHz}$	-14 dBm	30 kHz
$0.2 \text{ MHz} \leq \Delta f < 1 \text{ MHz}$	$0.215 \text{ MHz} \leq f_{\text{offset}} < 1.015 \text{ MHz}$	$-14 \text{ dBm} - 15 \cdot \left(\frac{f_{\text{offset}}}{\text{MHz}} - 0.215 \right) \text{ dB}$	30 kHz
(Note 6)	$1.015 \text{ MHz} \leq f_{\text{offset}} < 1.5 \text{ MHz}$	-26 dBm	30 kHz
$1 \text{ MHz} \leq \Delta f \leq 6 \text{ MHz}$	$1.5 \text{ MHz} \leq f_{\text{offset}} < 6.5 \text{ MHz}$	-13 dBm	1 MHz
$6 \text{ MHz} \leq \Delta f \leq \Delta f_{\text{max}}$	$6.5 \text{ MHz} \leq f_{\text{offset}} < f_{\text{offset}_{\text{max}}}$	-15 dBm	1 MHz
NOTE 1: For a <i>TAB connector</i> supporting non-contiguous spectrum operation within any operating band, the <i>basic limit</i> within sub-block gaps is calculated as a cumulative sum of contributions from adjacent sub blocks on each side of the sub block gap, where the contribution from the far-end sub-block shall be scaled according to the measurement bandwidth of the near-end sub-block. Exception is $\Delta f \geq 10 \text{ MHz}$ from both adjacent sub blocks on each side of the sub-block gap, where the <i>basic limit</i> within sub-block gaps shall be -15dBm/1MHz.			
NOTE 2: For a <i>multi-band TAB connector</i> with <i>Inter RF Bandwidth gap</i> < 20MHz the <i>basic limit</i> within the <i>Inter RF Bandwidth gaps</i> is calculated as a cumulative sum of contributions from adjacent sub-blocks or <i>Base Station RF Bandwidth</i> on each side of the <i>Inter RF Bandwidth gap</i> , where the contribution from the far-end sub-block or <i>Base Station RF Bandwidth</i> shall be scaled according to the measurement bandwidth of the near-end sub-block or <i>Base Station RF Bandwidth</i> .			

For a *TAB connector* operating in band 3 or 8, emissions shall not use the *basic limits* specified in Table 6.6.5.4.3.3-3 below for 1.4 MHz channel bandwidth:

Table 6.6.5.4.3.3-3: Regional Wide Area BS operating band unwanted emission limits in band 3 or 8 for 1.4 MHz channel bandwidth for Category B

Frequency offset of measurement filter -3dB point, Δf	Frequency offset of measurement filter centre frequency, f_{offset}	<i>basic limit</i> (Note 1, 2)	Measurement bandwidth (Note 5)
$0 \text{ MHz} \leq \Delta f < 0.05 \text{ MHz}$	$0.015 \text{ MHz} \leq f_{\text{offset}} < 0.065 \text{ MHz}$	$5 \text{ dBm} - 60 \cdot \left(\frac{f_{\text{offset}}}{\text{MHz}} - 0.015 \right) \text{ dB}$	30 kHz
$0.05 \text{ MHz} \leq \Delta f < 0.15 \text{ MHz}$	$0.065 \text{ MHz} \leq f_{\text{offset}} < 0.165 \text{ MHz}$	$2 \text{ dBm} - 160 \cdot \left(\frac{f_{\text{offset}}}{\text{MHz}} - 0.065 \right) \text{ dB}$	30 kHz
$0.15 \text{ MHz} \leq \Delta f < 0.2 \text{ MHz}$	$0.165 \text{ MHz} \leq f_{\text{offset}} < 0.215 \text{ MHz}$	-14 dBm	30 kHz
$0.2 \text{ MHz} \leq \Delta f < 1 \text{ MHz}$	$0.215 \text{ MHz} \leq f_{\text{offset}} < 1.015 \text{ MHz}$	$-14 \text{ dBm} - 15 \cdot \left(\frac{f_{\text{offset}}}{\text{MHz}} - 0.215 \right) \text{ dB}$	30 kHz
(Note 6)	$1.015 \text{ MHz} \leq f_{\text{offset}} < 1.5 \text{ MHz}$	-26 dBm	30 kHz
$1 \text{ MHz} \leq \Delta f \leq 2.8 \text{ MHz}$	$1.5 \text{ MHz} \leq f_{\text{offset}} < 3.3 \text{ MHz}$	-13 dBm	1 MHz
$2.8 \text{ MHz} \leq \Delta f \leq \Delta f_{\text{max}}$	$3.3 \text{ MHz} \leq f_{\text{offset}} < f_{\text{offset}_{\text{max}}}$	-15 dBm	1 MHz
NOTE 1: For a <i>TAB connector</i> supporting non-contiguous spectrum operation within any operating band, the <i>basic limit</i> within sub-block gaps is calculated as a cumulative sum of contributions from adjacent sub blocks on each side of the sub block gap, where the contribution from the far-end sub-block shall be scaled according to the measurement bandwidth of the near-end sub-block. Exception is $\Delta f \geq 10 \text{ MHz}$ from both adjacent sub blocks on each side of the sub-block gap, where the <i>basic limit</i> within sub-block gaps shall be -15dBm/1MHz.			
NOTE 2: For a <i>multi-band TAB connector</i> with <i>Inter RF Bandwidth gap</i> < 20MHz the <i>basic limit</i> within the <i>Inter RF Bandwidth gaps</i> is calculated as a cumulative sum of contributions from adjacent sub-blocks or <i>Base Station RF Bandwidth</i> on each side of the <i>Inter RF Bandwidth gap</i> , where the contribution from the far-end sub-block or <i>Base Station RF Bandwidth</i> shall be scaled according to the measurement bandwidth of the near-end sub-block or <i>Base Station RF Bandwidth</i> .			

6.6.5.4.4 Basic limits for Local Area BS (Category A and B)

For Local Area BS, *basic limits* are specified in Tables 6.6.5.4.4-1 to 6.6.5.4.4-3.

Table 6.6.5.4.4-1: Local Area BS operating band unwanted emission limits for 1.4 MHz channel bandwidth

Frequency offset of measurement filter -3dB point, Δf	Frequency offset of measurement filter centre frequency, f_{offset}	<i>basic limit</i> (Note 1, 2)	Measurement bandwidth (Note 5)
0 MHz $\leq \Delta f < 1.4$ MHz	0.05 MHz $\leq f_{\text{offset}} < 1.45$ MHz	$-21\text{dBm} - \frac{10}{1.4} \left(\frac{f_{\text{offset}}}{\text{MHz}} - 0.05 \right) \text{dB}$	100 kHz
1.4 MHz $\leq \Delta f < 2.8$ MHz	1.45 MHz $\leq f_{\text{offset}} < 2.85$ MHz	-31 dBm	100 kHz
2.8 MHz $\leq \Delta f \leq \Delta f_{\text{max}}$	2.85 MHz $\leq f_{\text{offset}} < f_{\text{offset}_{\text{max}}}$	-31 dBm	100 kHz
NOTE 1: For a <i>TAB connector</i> supporting non-contiguous spectrum operation within any operating band the <i>basic limit</i> within sub-block gaps is calculated as a cumulative sum of contributions from adjacent sub blocks on each side of the sub block gap. Exception is $\Delta f \geq 10\text{MHz}$ from both adjacent sub blocks on each side of the sub-block gap, where the <i>basic limit</i> within sub-block gaps shall be -31dBm/100kHz.			
NOTE 2: For a <i>multi-band TAB connector</i> with <i>Inter RF Bandwidth gap</i> $< 20\text{MHz}$ the <i>basic limit</i> within the <i>Inter RF Bandwidth gaps</i> is calculated as a cumulative sum of contributions from adjacent sub-blocks or <i>Base Station RF Bandwidth</i> on each side of the <i>Inter RF Bandwidth gap</i> .			

Table 6.6.5.4.4-2: Local Area BS operating band unwanted emission limits for 3 MHz channel bandwidth

Frequency offset of measurement filter -3dB point, Δf	Frequency offset of measurement filter centre frequency, f_{offset}	<i>basic limit</i> (Note 1, 2)	Measurement bandwidth (Note 5)
0 MHz $\leq \Delta f < 3$ MHz	0.05 MHz $\leq f_{\text{offset}} < 3.05$ MHz	$-25\text{dBm} - \frac{10}{3} \left(\frac{f_{\text{offset}}}{\text{MHz}} - 0.05 \right) \text{dB}$	100 kHz
3 MHz $\leq \Delta f < 6$ MHz	3.05 MHz $\leq f_{\text{offset}} < 6.05$ MHz	-35 dBm	100 kHz
6 MHz $\leq \Delta f \leq \Delta f_{\text{max}}$	6.05 MHz $\leq f_{\text{offset}} < f_{\text{offset}_{\text{max}}}$	-35 dBm	100 kHz
NOTE 1: For a <i>TAB connector</i> supporting non-contiguous spectrum operation within any operating band the <i>basic limit</i> within sub-block gaps is calculated as a cumulative sum of contributions from adjacent sub blocks on each side of the sub block gap. Exception is $\Delta f \geq 10\text{MHz}$ from both adjacent sub blocks on each side of the sub-block gap, where the <i>basic limit</i> within sub-block gaps shall be -35dBm/100kHz.			
NOTE 2: For a <i>multi-band TAB connector</i> with <i>Inter RF Bandwidth gap</i> $< 20\text{MHz}$ the <i>basic limit</i> within the <i>Inter RF Bandwidth gaps</i> is calculated as a cumulative sum of contributions from adjacent sub-blocks or <i>Base Station RF Bandwidth</i> on each side of the <i>Inter RF Bandwidth gap</i> .			

Table 6.6.5.4.4-3: Local Area BS operating band unwanted emission limits for 5, 10, 15 and 20 MHz channel bandwidth

Frequency offset of measurement filter -3dB point, Δf	Frequency offset of measurement filter centre frequency, f_{offset}	<i>basic limit</i> (Note 1, 2)]	Measurement bandwidth (Note 5)
0 MHz $\leq \Delta f < 5$ MHz	0.05 MHz $\leq f_{\text{offset}} < 5.05$ MHz	$-30\text{dBm} - \frac{7}{5} \left(\frac{f_{\text{offset}}}{\text{MHz}} - 0.05 \right) \text{dB}$	100 kHz
5 MHz $\leq \Delta f < \min(10 \text{ MHz}, \Delta f_{\text{max}})$	5.05 MHz $\leq f_{\text{offset}} < \min(10.05 \text{ MHz}, f_{\text{offset}_{\text{max}}})$	-37 dBm	100 kHz
10 MHz $\leq \Delta f \leq \Delta f_{\text{max}}$	10.05 MHz $\leq f_{\text{offset}} < f_{\text{offset}_{\text{max}}}$	-37 dBm (Note 7)	100 kHz
NOTE 1: For a <i>TAB connector</i> supporting non-contiguous spectrum operation within any operating band the <i>basic limit</i> within sub-block gaps is calculated as a cumulative sum of contributions from adjacent sub blocks on each side of the sub block gap. Exception is $\Delta f \geq 10\text{MHz}$ from both adjacent sub blocks on each side of the sub-block gap, where the <i>basic limit</i> within sub-block gaps shall be -37dBm/100kHz.			
NOTE 2: For a <i>multi-band TAB connector</i> with <i>Inter RF Bandwidth gap</i> $< 20\text{MHz}$ the <i>basic limit</i> within the <i>Inter RF Bandwidth gaps</i> is calculated as a cumulative sum of contributions from adjacent sub-blocks or <i>Base Station RF Bandwidth</i> on each side of the <i>Inter RF Bandwidth gap</i> .			

6.6.5.4.5 Basic limits for Medium Range BS (Category A and B)

For Medium Range BS, *basic limits* are specified in Tables 6.6.5.4.5-1 to 6.6.5.4.5-6.

Table 6.6.5.4.5-1: Medium Range BS operating band unwanted emission limits for 1.4 MHz channel bandwidth, $31 < P_{\max,c,cell} - 10 \cdot \log_{10}(N_{\text{TXU,countedpercell}}) \leq 38$ dBm

Frequency offset of measurement filter -3dB point, Δf	Frequency offset of measurement filter centre frequency, f_{offset}	<i>basic limit</i> (Note 1, 2)	Measurement bandwidth (Note 5)
0 MHz $\leq \Delta f < 1.4$ MHz	0.05 MHz $\leq f_{\text{offset}} < 1.45$ MHz	$P_{\max,c,cell} - 10 \cdot \log_{10}(N_{\text{TXU,countedpercell}}) - 45 \text{ dB} - \frac{10}{1.4} \left(\frac{f_{\text{offset}}}{\text{MHz}} - 0.05 \right) \text{ dB}$	100 kHz
1.4 MHz $\leq \Delta f < 2.8$ MHz	1.45 MHz $\leq f_{\text{offset}} < 2.85$ MHz	$P_{\max,c,cell} - 10 \cdot \log_{10}(N_{\text{TXU,countedpercell}}) - 55 \text{ dB}$	100 kHz
2.8 MHz $\leq \Delta f \leq \Delta f_{\max}$	2.85 MHz $\leq f_{\text{offset}} < f_{\text{offset}_{\max}}$	-25dBm	100 kHz
NOTE 1: For a <i>TAB connector</i> supporting non-contiguous spectrum operation within any operating band the <i>basic limit</i> within sub-block gaps is calculated as a cumulative sum of contributions from adjacent sub blocks on each side of the sub block gap. Exception is $\Delta f \geq 10$ MHz from both adjacent sub blocks on each side of the sub-block gap, where the <i>basic limit</i> within sub-block gaps shall be -25dBm/100kHz.			
NOTE 2: For a <i>multi-band TAB connector</i> with <i>Inter RF Bandwidth gap</i> < 20 MHz the <i>basic limit</i> within the <i>Inter RF Bandwidth gaps</i> is calculated as a cumulative sum of contributions from adjacent sub-blocks or <i>Base Station RF Bandwidth</i> on each side of the <i>Inter RF Bandwidth gap</i> .			

Table 6.6.5.4.5-2: Medium Range BS operating band unwanted emission limits for 1.4 MHz channel bandwidth, $P_{\max,c,cell} - 10 \cdot \log_{10}(N_{\text{TXU,countedpercell}}) \leq 31$ dBm

Frequency offset of measurement filter -3dB point, Δf	Frequency offset of measurement filter centre frequency, f_{offset}	<i>basic limit</i> (Note 1, 2)	Measurement bandwidth (Note 5)
0 MHz $\leq \Delta f < 1.4$ MHz	0.05 MHz $\leq f_{\text{offset}} < 1.45$ MHz	$-14 \text{ dBm} - \frac{10}{1.4} \left(\frac{f_{\text{offset}}}{\text{MHz}} - 0.05 \right) \text{ dB}$	100 kHz
1.4 MHz $\leq \Delta f < 2.8$ MHz	1.45 MHz $\leq f_{\text{offset}} < 2.85$ MHz	-24 dBm	100 kHz
2.8 MHz $\leq \Delta f \leq \Delta f_{\max}$	2.85 MHz $\leq f_{\text{offset}} < f_{\text{offset}_{\max}}$	-25dBm	100 kHz
NOTE 1: For a <i>TAB connector</i> supporting non-contiguous spectrum operation within any operating band the <i>basic limit</i> within sub-block gaps is calculated as a cumulative sum of contributions from adjacent sub blocks on each side of the sub block gap. Exception is $\Delta f \geq 10$ MHz from both adjacent sub blocks on each side of the sub-block gap, where the <i>basic limit</i> within sub-block gaps shall be -25dBm/100kHz.			
NOTE 2: For a <i>multi-band TAB connector</i> with <i>Inter RF Bandwidth gap</i> < 20 MHz the <i>basic limit</i> within the <i>Inter RF Bandwidth gaps</i> is calculated as a cumulative sum of contributions from adjacent sub-blocks or <i>Base Station RF Bandwidth</i> on each side of the <i>Inter RF Bandwidth gap</i> .			

Table 6.6.5.4.5-3: Medium Range BS operating band unwanted emission limits for 3 MHz channel bandwidth, $31 < P_{\max,c,cell} - 10 \cdot \log_{10}(N_{\text{TXU,countedpercell}}) \leq 38$ dBm

Frequency offset of measurement filter -3dB point, Δf	Frequency offset of measurement filter centre frequency, f_{offset}	<i>basic limit</i> (Note 1, 2)	Measurement bandwidth (Note 5)
$0 \text{ MHz} \leq \Delta f < 3 \text{ MHz}$	$0.05 \text{ MHz} \leq f_{\text{offset}} < 3.05 \text{ MHz}$	$P_{\max,c,cell} - 10 \cdot \log_{10}(N_{\text{TXU,countedpercell}}) - 49 \text{ dB} - \frac{10}{3} \left(\frac{f_{\text{offset}}}{\text{MHz}} - 0.05 \right) \text{ dB}$	100 kHz
$3 \text{ MHz} \leq \Delta f < 6 \text{ MHz}$	$3.05 \text{ MHz} \leq f_{\text{offset}} < 6.05 \text{ MHz}$	$P_{\max,c,cell} - 10 \cdot \log_{10}(N_{\text{TXU,countedpercell}}) - 59 \text{ dB}$	100 kHz
$6 \text{ MHz} \leq \Delta f \leq \Delta f_{\max}$	$6.05 \text{ MHz} \leq f_{\text{offset}} < f_{\text{offset}_{\max}}$	$\text{Min}(P_{\max,c,cell} - 10 \cdot \log_{10}(N_{\text{TXU,countedpercell}}) - 59 \text{ dB}, -25 \text{ dBm})$	100 kHz
<p>NOTE 1: For a <i>TAB connector</i> supporting non-contiguous spectrum operation within any operating band the <i>basic limit</i> within sub-block gaps is calculated as a cumulative sum of contributions from adjacent sub blocks on each side of the sub block gap. Exception is $\Delta f \geq 10 \text{ MHz}$ from both adjacent sub blocks on each side of the sub-block gap, where the <i>basic limit</i> within sub-block gaps shall be $\text{Min}(P_{\max,c,cell} - 10 \cdot \log_{10}(N_{\text{TXU,countedpercell}}) - 59 \text{ dB}, -25 \text{ dBm})/100 \text{ kHz}$.</p> <p>NOTE 2: For a <i>multi-band TAB connector</i> with <i>Inter RF Bandwidth gap</i> $< 20 \text{ MHz}$ the <i>basic limit</i> within the <i>Inter RF Bandwidth gaps</i> is calculated as a cumulative sum of contributions from adjacent sub-blocks or <i>Base Station RF Bandwidth</i> on each side of the <i>Inter RF Bandwidth gap</i>.</p>			

Table 6.6.5.4.5-4: Medium Range BS operating band unwanted emission limits for 3 MHz channel bandwidth, $P_{\max,c,cell} - 10 \cdot \log_{10}(N_{\text{TXU,countedpercell}}) \leq 31$ dBm

Frequency offset of measurement filter -3dB point, Δf	Frequency offset of measurement filter centre frequency, f_{offset}	<i>basic limit</i> (Note 1, 2)	Measurement bandwidth (Note 5)
$0 \text{ MHz} \leq \Delta f < 3 \text{ MHz}$	$0.05 \text{ MHz} \leq f_{\text{offset}} < 3.05 \text{ MHz}$	$-18 \text{ dBm} - \frac{10}{3} \left(\frac{f_{\text{offset}}}{\text{MHz}} - 0.05 \right) \text{ dB}$	100 kHz
$3 \text{ MHz} \leq \Delta f < 6 \text{ MHz}$	$3.05 \text{ MHz} \leq f_{\text{offset}} < 6.05 \text{ MHz}$	-28 dBm	100 kHz
$6 \text{ MHz} \leq \Delta f \leq \Delta f_{\max}$	$6.05 \text{ MHz} \leq f_{\text{offset}} < f_{\text{offset}_{\max}}$	-28 dBm	100 kHz
<p>NOTE 1: For a <i>TAB connector</i> supporting non-contiguous spectrum operation within any operating band the <i>basic limit</i> within sub-block gaps is calculated as a cumulative sum of contributions from adjacent sub blocks on each side of the sub block gap. Exception is $\Delta f \geq 10 \text{ MHz}$ from both adjacent sub blocks on each side of the sub-block gap, where the <i>basic limit</i> within sub-block gaps shall be $-28 \text{ dBm}/100 \text{ kHz}$.</p> <p>NOTE 2: For a <i>multi-band TAB connector</i> with <i>Inter RF Bandwidth gap</i> $< 20 \text{ MHz}$ the <i>basic limit</i> within the <i>Inter RF Bandwidth gaps</i> is calculated as a cumulative sum of contributions from adjacent sub-blocks or <i>Base Station RF Bandwidth</i> on each side of the <i>Inter RF Bandwidth gap</i>.</p>			

Table 6.6.5.4.5-5: Medium Range BS operating band unwanted emission limits for 5, 10, 15 and 20 MHz channel bandwidth, $31 < P_{\max,c,cell} - 10 \cdot \log_{10}(N_{\text{TXU,countedpercell}}) \leq 38$ dBm

Frequency offset of measurement filter -3dB point, Δf	Frequency offset of measurement filter centre frequency, f_{offset}	<i>basic limit</i> (Note 1, 2)	Measurement bandwidth (Note 5)
$0 \text{ MHz} \leq \Delta f < 5 \text{ MHz}$	$0.05 \text{ MHz} \leq f_{\text{offset}} < 5.05 \text{ MHz}$	$P_{\max,c,cell} - 10 \cdot \log_{10}(N_{\text{TXU,countedpercell}}) - 53 \text{ dB} - \frac{7}{5} \left(\frac{f_{\text{offset}}}{\text{MHz}} - 0.05 \right) \text{ dB}$	100 kHz
$5 \text{ MHz} \leq \Delta f < \min(10 \text{ MHz}, \Delta f_{\max})$	$5.05 \text{ MHz} \leq f_{\text{offset}} < \min(10.05 \text{ MHz}, f_{\text{offset,max}})$	$P_{\max,c,cell} - 10 \cdot \log_{10}(N_{\text{TXU,countedpercell}}) - 60 \text{ dB}$	100 kHz
$10 \text{ MHz} \leq \Delta f \leq \Delta f_{\max}$	$10.05 \text{ MHz} \leq f_{\text{offset}} < f_{\text{offset,max}}$	$\text{Min}(P_{\max,c,cell} - 10 \cdot \log_{10}(N_{\text{TXU,countedpercell}}) - 60 \text{ dB}, -25 \text{ dBm})$ (Note 6)	100 kHz
<p>NOTE 1: For a <i>TAB connector</i> supporting non-contiguous spectrum operation within any operating band the <i>basic limit</i> within sub-block gaps is calculated as a cumulative sum of contributions from adjacent sub blocks on each side of the sub block gap. Exception is $\Delta f \geq 10 \text{ MHz}$ from both adjacent sub blocks on each side of the sub-block gap, where the <i>basic limit</i> within sub-block gaps shall be $\text{Min}(P_{\max,c,cell} - 10 \cdot \log_{10}(N_{\text{TXU,countedpercell}}) - 60 \text{ dB}, -25 \text{ dBm})/100 \text{ kHz}$.</p> <p>NOTE 2: For a <i>multi-band TAB connector</i> with <i>Inter RF Bandwidth gap</i> $< 20 \text{ MHz}$ the <i>basic limit</i> within the <i>Inter RF Bandwidth gaps</i> is calculated as a cumulative sum of contributions from adjacent sub-blocks or <i>Base Station RF Bandwidth</i> on each side of the <i>Inter RF Bandwidth gap</i>.</p>			

Table 6.6.5.4.5-6: Medium Range BS operating band unwanted emission limits for 5, 10, 15 and 20 MHz channel bandwidth, $P_{\max,c,cell} - 10 \cdot \log_{10}(N_{\text{TXU,countedpercell}}) \leq 31$ dBm

Frequency offset of measurement filter -3dB point, Δf	Frequency offset of measurement filter centre frequency, f_{offset}	<i>basic limit</i> (Note 1, 2)	Measurement bandwidth (Note 5)
$0 \text{ MHz} \leq \Delta f < 5 \text{ MHz}$	$0.05 \text{ MHz} \leq f_{\text{offset}} < 5.05 \text{ MHz}$	$-22 \text{ dBm} - \frac{7}{5} \left(\frac{f_{\text{offset}}}{\text{MHz}} - 0.05 \right) \text{ dB}$	100 kHz
$5 \text{ MHz} \leq \Delta f < \min(10 \text{ MHz}, \Delta f_{\max})$	$5.05 \text{ MHz} \leq f_{\text{offset}} < \min(10.05 \text{ MHz}, f_{\text{offset,max}})$	-29 dBm	100 kHz
$10 \text{ MHz} \leq \Delta f \leq \Delta f_{\max}$	$10.05 \text{ MHz} \leq f_{\text{offset}} < f_{\text{offset,max}}$	-29 dBm (Note 6)	100 kHz
<p>NOTE 1: For a <i>TAB connector</i> supporting non-contiguous spectrum operation within any operating band the <i>basic limit</i> within sub-block gaps is calculated as a cumulative sum of contributions from adjacent sub blocks on each side of the sub block gap. Exception is $\Delta f \geq 10 \text{ MHz}$ from both adjacent sub blocks on each side of the sub-block gap, where the <i>basic limit</i> within sub-block gaps shall be $-29 \text{ dBm}/100 \text{ kHz}$.</p> <p>NOTE 2: For a <i>multi-band TAB connector</i> with <i>Inter RF Bandwidth gap</i> $< 20 \text{ MHz}$ the <i>basic limit</i> within the <i>Inter RF Bandwidth gaps</i> is calculated as a cumulative sum of contributions from adjacent sub-blocks or <i>Base Station RF Bandwidth</i> on each side of the <i>Inter RF Bandwidth gap</i>.</p>			

6.6.5.4.6 Void

6.6.5.4.7 Additional requirements

The E-UTRA operating band unwanted emission *basic limits* for additional requirements are the same as the *basic limit* s specified in 3GPP TS 36.104 [8], subclause 6.6.3.3.

6.6.6 Spurious emission

6.6.6.1 General

The transmitter spurious emission limits apply from 9 kHz to 12.75 GHz, excluding the frequency range from 10 MHz below the lowest frequency of the *downlink operating band* up to 10 MHz above the highest frequency of the *downlink operating band*. For some operating bands the upper frequency limit is higher than 12.75 GHz. In some exceptional cases, requirements apply also closer than 10 MHz from the *downlink operating band*; these cases are highlighted in the requirement tables in respective referenced UTRA, E-UTRA or MSR specifications. For operating bands supported by *multi-band TAB connectors* exclusion bands apply to each supported band.

The requirements applies for both single band and multiband *TAB connectors* (except for frequencies at which exclusion bands or other multi-band provisions apply) and for all transmission modes foreseen by the manufacturer's specification. Unless otherwise stated, all requirements are measured as mean power.

For operation in region 2, where the FCC guidance for MIMO systems in [18] is applicable, $N_{\text{TXU, countedpercell}}$ shall be equal to 1 for the purposes of calculating the spurious emissions limits in subclauses 6.6.6.2, 6.6.6.3 or 6.6.6.4. For all other unwanted emissions requirements, $N_{\text{TXU, countedpercell}}$ shall be the value calculated according to subclause 6.1.

The AAS BS requirements for spurious emissions limits which are specified for Band 46 in 3GPP TS 37.104 [5], are applicable for AAS BS.

6.6.6.2 Minimum requirement for MSR operation

The MSR spurious emission *basic limits* are the same as those specified in 3GPP TS 37.104 [9], subclauses 6.6.1.1, 6.6.1.2, 6.6.1.3 and 6.6.1.4.

The spurious emission requirements for an MSR AAS BS are that for each *TAB connector TX mincell group* and each applicable *basic limit* as specified in 3GPP TS 37.104 [5], the power summation emissions at the *TAB connectors* of the *TAB connector TX min cell group* shall not exceed an AAS limit specified as the *basic limit* + $10\log_{10}(N_{\text{TXU, countedpercell}})$.

NOTE: Conformance to the AAS BS spurious emission requirement can be demonstrated by meeting at least one of the following criteria as determined by the manufacturer:

- 1) The sum of the emissions power measured on each *TAB connector* in the *TAB connector TX min cell group* shall be less than or equal to the AAS BS limit as defined in this subclause for the respective frequency span.

Or

- 2) The unwanted emissions power at each *TAB connector* shall be less than or equal to the AAS BS limit as defined in this subclause for the respective frequency span, scaled by $-10\log_{10}(n)$, where n is the number of *TAB connectors* in the *TAB connector TX min cell group*.

6.6.6.3 Minimum requirement for single RAT UTRA operation

The single RAT UTRA FDD spurious emission *basic limits* are the same as those specified in 3GPP TS 25.104 [6], subclauses 6.6.3.1-6.6.3.8.

The single RAT UTRA TDD spurious emission *basic limits* are the same as those specified in 3GPP TS 25.105 [7], subclauses 6.6.3.1-6.6.3.5.

The spurious emission requirements for a UTRA single RAT AAS BS are that for each *TAB connector TX min cell group* and each applicable *basic limit* as specified in 3GPP TS 25.104 [6] or 3GPP TS 25.105 [7], the power sum of the emissions at the *TAB connectors* associated with the *TAB connector TX min cell group* shall not exceed an AAS limit specified as the *basic limit* + $10\log_{10}(N_{\text{TXU, countedpercell}})$.

NOTE: Conformance to the AAS BS spurious emission requirement can be demonstrated by meeting at least one of the following criteria as determined by the manufacturer:

- 1) The sum of the emissions power measured on each *TAB connector* in the *TAB connector TX min cell group* shall be less than or equal to the AAS BS limit as defined in this subclause for the respective frequency span.

Or

- 2) The unwanted emissions power at each *TAB connector* shall be less than or equal to the AAS BS limit as defined in this subclause for the respective frequency span, scaled by $-10\log_{10}(n)$, where n is the number of *TAB connectors* in the *TAB connector TX min cell group*.

6.6.6.4 Minimum requirement for single RAT E-UTRA operation

Single RAT E-UTRA operation spurious emission *basic limits* are the same as those specified in 3GPP TS 36.104 [8], subclauses 6.6.4.1-6.6.4.4.

The spurious emission requirements for AAS BS in *single RAT E-UTRA operation* are that for each *TAB connector TX min cell group* and for each applicable *basic limit* as specified in 3GPP TS 36.104 [4], the total emissions at the *TAB connectors* associated with the *TAB connector TX min cell group* shall not exceed an AAS limit specified as the *basic limit* + $10\log_{10}(N_{\text{TXU, counted per cell}})$.

NOTE: Conformance to the AAS BS spurious emission requirement can be demonstrated by meeting at least one of the following criteria as determined by the manufacturer:

- 1) The sum of the emissions power measured on each *TAB connector* in the *TAB connector TX min cell group* shall be less than or equal to the AAS BS limit as defined in this subclause for the respective frequency span.

Or

- 2) The unwanted emissions power at each *TAB connector* shall be less than or equal to the AAS BS limit as defined in this subclause for the respective frequency span, scaled by $-10\log_{10}(n)$, where n is the number of *TAB connectors* in the *TAB connector TX min cell group*.

6.7 Transmitter intermodulation

6.7.1 General

The transmitter intermodulation requirement is a measure of the capability of the transmitter unit to inhibit the generation of signals in its non-linear elements caused by presence of the wanted signal and an interfering signal reaching the transmitter unit via the RDN and antenna array. The requirement applies during the *transmitter ON period* and the *transmitter transient period*.

The requirement applies at each *TAB connector* supporting transmission in the operating band.

The transmitter intermodulation level is the power of the intermodulation products when an interfering signal is injected into the *TAB connector*.

For AAS BS there are two types of transmitter intermodulation cases captured by the transmitter intermodulation requirement:

- 1) Co-location transmitter intermodulation in which the interfering signal is from a co-located base station.
- 2) Intra-system transmitter intermodulation in which the interfering signal is from other transmitter units within the AAS BS.

For AAS BS, the co-location transmitter intermodulation requirement is considered sufficient if the interfering signal for the co-location requirement is higher than the declared interfering signal for intra-system transmitter intermodulation requirement.

6.7.2 Minimum requirement for MSR operation

6.7.2.1 General co-location minimum requirement

The transmitter intermodulation level shall not exceed the unwanted emission limits specified for transmitter spurious emission in subclause 6.6.6, operating band unwanted emission in subclause 6.6.5 and ACLR in subclause 6.6.3 in the presence of a wanted signal and an interfering signal according to table 6.7.2.1-1 for AAS BS operation in BC1, BC2 and BC3.

The requirement is applicable outside the *Base Station RF Bandwidth edges*. The interfering signal offset is defined relative to the *Base Station RF Bandwidth edges* or *Radio Bandwidth edges*.

For *TAB connectors* supporting operation in *non-contiguous spectrum*, the requirement is also applicable inside a *sub-block gap* for interfering signal offsets where the interfering signal falls completely within the *sub-block gap*. The interfering signal offset is defined relative to the *sub-block* edges.

For *TAB connectors* supporting operation in multiple operating bands, the requirement applies relative to the *Base Station RF Bandwidth edges* of each operating band. In case the inter *Base Station RF Bandwidth* gap is less than 15 MHz, the requirement in the gap applies only for interfering signal offsets where the interfering signal falls completely within the inter *Base Station RF Bandwidth* gap.

Table 6.7.2.1-1: Interfering and wanted signals for the co-location transmitter intermodulation requirement

Parameter	Value
Wanted signal type	E-UTRA signal
Interfering signal type	E-UTRA signal of <i>channel bandwidth</i> 5 MHz
Interfering signal level	Rated total output power per <i>TAB connector</i> in the operating band ($P_{\text{Rated,t,TABC}} - 30\text{dB}$)
Interfering signal centre frequency offset from <i>Base Station RF Bandwidth</i> edge or edge of <i>sub-block</i> inside a gap	± 2.5 MHz ± 7.5 MHz ± 12.5 MHz
NOTE 1: Interfering signal positions that are partially or completely outside of any <i>downlink operating band</i> of the <i>TAB connector</i> are excluded from the requirement, unless the interfering signal positions fall within the frequency range of adjacent <i>downlink operating bands</i> in the same geographical area. In case that none of the interfering signal positions fall completely within the frequency range of the <i>downlink operating band</i> , 3GPP TS 37.141 [19] provides further guidance regarding appropriate test requirements.	
NOTE 2: In certain regions, note 1 is not applied in Band 1, 3, 8, 9, 11, 18, 19, 21, 28, 32 operating within 1 475.9 MHz to 1 495.9 MHz, 34.	

6.7.2.2 Additional co-location minimum requirement (BC1 and BC2)

The transmitter intermodulation level shall not exceed the unwanted emission limits specified for transmitter spurious emission in subclause 6.6.6, operating band unwanted emission in subclause 6.6.5 and ACLR in subclause 6.6.3 in the presence of a wanted signal and an interfering signal according to table 6.7.2.2-1 for BS operation in BC2.

The requirement is applicable outside the *Base Station RF Bandwidth* edges for BC2. The interfering signal offset is defined relative to the *Base Station RF Bandwidth* edges.

For *TAB connectors* supporting operation in *non-contiguous spectrum* in BC1 or BC2, the requirement is also applicable inside a *sub-block gap* with a gap size larger than or equal to two times the interfering signal centre frequency offset. For *TAB connectors* supporting operation in *non-contiguous spectrum* in BC1, the requirement is not applicable inside a *sub-block gap* with a gap size equal to or larger than 5 MHz. The interfering signal offset is defined relative to the *sub-block* edges.

For *TAB connectors* supporting operation in multiple operating bands, the requirement applies relative to the *Base Station RF Bandwidth edges* of a BC2 operating band. The requirement is also applicable for BC1 and BC2 inside an inter *Base Station RF Bandwidth* gap equal to or larger than two times the interfering signal centre frequency offset. For *TAB connectors* supporting operation in multiple operating bands, the requirement is not applicable for BC1 band inside an inter *Base Station RF Bandwidth* gap with a gap size equal to or larger than 5 MHz.

Table 6.7.2.2-1: Interfering and wanted signals for the co-location transmitter intermodulation requirement

Parameter	Value
Wanted signal type	E-UTRA and/or UTRA signal
Interfering signal type	CW
Interfering signal level	Rated total output power per <i>TAB connector</i> in the operating band ($P_{\text{Rated,t,TABC}} - 30\text{dB}$)
Interfering signal centre frequency offset from <i>Base Station RF Bandwidth</i> edge or edge of <i>sub-block</i> inside a gap	> abs(800) kHz for CW interferer
NOTE: Interfering signal positions that are partially or completely outside of any <i>downlink operating band</i> of the <i>TAB connector</i> are excluded from the requirement.	

6.7.2.3 Additional co-location minimum requirement (BC3)

The transmitter intermodulation level shall not exceed the unwanted emission limits specified for transmitter spurious emission in subclause 6.6.6, operating band unwanted emission in subclause 6.6.5 and ACLR in subclause 6.6.3 in the presence of a wanted signal and an interfering signal according to table 6.7.2.3-1 for AAS BS operation in BC3.

For *TAB connectors* supporting operation in multiple operating bands, the requirement applies relative to *the Base Station RF Bandwidth edges* of each operating band. In case the *Inter RF Bandwidth gap* is less than 3.2 MHz, the requirement in the gap applies only for interfering signal offsets where the interfering signal falls completely within the inter *Base Station RF Bandwidth* gap.

Table 6.7.2.3-1: Interfering and wanted signals for the co-location transmitter intermodulation requirement (BC3)

Parameter	Value
Wanted signal type	E-UTRA and/or UTRA signal
Interfering signal type	1,28 Mcps UTRA TDD signal of <i>channel bandwidth</i> 1,6 MHz
Interfering signal level	Rated total output power per <i>TAB connector</i> in the operating band ($P_{\text{Rated,t,TABC}} - 30\text{dB}$)
Interfering signal centre frequency offset from <i>Base Station RF Bandwidth</i> edge or edge of <i>sub-block</i> inside a gap	$\pm 0,8$ MHz $\pm 1,6$ MHz $\pm 2,4$ MHz
NOTE: Interfering signal positions that are partially or completely outside of any <i>downlink operating band</i> of the base station are excluded from the requirement.	

6.7.2.4 Additional co-location minimum requirements

In certain regions additional co-location minimum requirements as specified in subclause 6.7.4.2 applies.

6.7.2.5 Intra-system minimum requirement

The transmitter intermodulation level shall not exceed the unwanted emission limits specified for operating band unwanted emission in subclause 6.6.5 and ACLR in subclause 6.6.3 in the presence of a wanted signal and an interfering signal according to table 6.7.2.5-1 for BS operation in BC1, BC2 and BC3.

Table 6.7.2.5-1: Interfering and wanted signals for intra-system transmitter intermodulation requirement

Parameter	Value
Wanted signal type	E-UTRA or UTRA
Interfering signal type	E-UTRA or UTRA signal of the same <i>channel bandwidth</i> as the wanted signal (note 1).
Interfering signal level	Power level declared by the base station manufacturer (note 2).
Frequency offset between interfering signal and wanted signal	0 MHz
NOTE 1: The interfering signal shall be incoherent with the wanted signal.	
NOTE 2: The declared interfering signal power level at each <i>TAB connector</i> is the sum of the co-channel leakage power coupled via the combined RDN and Antenna Array from all the other <i>TAB connectors</i> , but does not comprise power radiated from the Antenna Array and reflected back from the environment. The power at each of the interfering <i>TAB connectors</i> is $P_{\text{Rated,c,TABC}}$.	

6.7.3 Minimum requirement for single RAT UTRA operation

6.7.3.1 General co-location minimum requirement for FDD UTRA

The transmitter intermodulation level shall not exceed the out of band emission or the spurious emission requirements of subclause 6.6.5 and subclause 6.6.6 in the presence of interfering signal according to table 6.7.3.1-1.

Table 6.7.3.1-1: Interfering and wanted signal frequency offset for co-location requirement

Parameter	Value
Wanted signal type	UTRA
Interfering signal type	UTRA
Interfering signal level	Rated total output power per <i>TAB connector</i> in the operating band ($P_{\text{Rated,t,TABC}} - 30\text{dB}$)
Interfering signal centre frequency offset from the lower (upper) edge of the wanted signal or edge of <i>sub-block</i> inside a gap	-2,5 MHz -7,5 MHz -12,5 MHz +2,5 MHz +7,5 MHz +12,5 MHz
NOTE 1: Interference frequencies that are outside of any allocated frequency band for UTRA-FDD downlink specified in subclause 4.6 are excluded from the requirement, unless the interfering signal positions fall within the frequency range of adjacent <i>downlink operating bands</i> in the same geographical area.	
NOTE 2: Note 1 is not applied in Band I, III, VI, VIII, IX, XI, XIX, XXI, and XXXII operating within 1 475.9 MHz to 1 495.9MHz, in certain regions.	

For *TAB connectors* supporting operation in *non-contiguous spectrum*, the requirement is also applicable inside a *sub-block gap* for interfering signal offsets where the interfering signal falls completely within the *sub-block gap*. The interfering signal offset is defined relative to the *sub-block* edges.

For *TAB connectors* supporting operation in multiple operating bands, the requirement is also applicable inside an inter *Base Station RF Bandwidth* gap for interfering signal offsets where the interfering signal falls completely within the inter *Base Station RF Bandwidth* gap.

6.7.3.2 General co-location minimum requirement for 1,28 Mcps TDD UTRA

The transmitter intermodulation level shall not exceed the out of band emission or the spurious emission requirements of subclause 6.6.5 and subclause 6.6.6 in the presence of interfering signal according to table 6.7.3.2-1.

Table 6.7.3.2-1: Interfering and wanted signals frequency offset for co-location requirement

Parameter	Value
Wanted signal type	1,28 Mcps TDD UTRA
Interfering signal type	1,28 Mcps TDD UTRA
Interfering signal level	Rated total output power per <i>TAB connector</i> in the operating band ($P_{\text{Rated,t,TABC}}$) – 30dB
Interfering signal centre frequency offset from the lower (upper) edge of the wanted signal	-0,8 MHz -2,4MHz -4,0 MHz +0,8 MHz +2,4 MHz +4,0 MHz
NOTE:	Interference frequencies that are outside of the allocated frequency band specified in subclause 4.6 are excluded from the requirement, unless the interfering signal positions fall within the frequency range of adjacent <i>downlink operating bands</i> in the same geographical area.

For *TAB connectors* supporting operation in *non-contiguous spectrum*, the requirement is also applicable inside a *sub-block gap* for interfering signal offsets where the interfering signal falls completely within the *sub-block gap*. The interfering signal offset is defined relative to the *sub-block* edges.

For *TAB connectors* supporting operation in multiple operating band, the requirement is also applicable inside an inter *Base Station RF Bandwidth* gap for interfering signal offsets where the interfering signal falls completely within the inter *Base Station RF Bandwidth* gap.

6.7.3.3 Intra-system minimum requirement

The transmitter intermodulation level shall not exceed the unwanted emission limits specified for operating band unwanted emission in subclause 6.6.5 and ACLR in subclause 6.6.3 in the presence of a wanted signal and an interfering signal according to table 6.7.3.3-1 for AAS BS.

Table 6.7.3.3-1: Interfering and wanted signals for intra-system transmitter intermodulation requirement

Parameter	Value
Wanted signal type	UTRA or 1,28 Mcps TDD UTRA
Interfering signal type	UTRA or 1,28 Mcps TDD UTRA signal of the same <i>channel bandwidth</i> as the wanted signal (note 1).
Interfering signal level	Power level declared by the base station manufacturer (note 2).
Frequency offset between interfering signal and wanted signal	0 MHz
NOTE 1:	The interfering signal shall be incoherent with the wanted signal.
NOTE 2:	The declared interfering signal power level at each <i>TAB connector</i> is the sum of the co-channel leakage power coupled via the combined RDN and Antenna Array from all the other <i>TAB connectors</i> , but does not comprise power radiated from the Antenna Array and reflected back from the environment. The power at each of the interfering <i>TAB connectors</i> is $P_{\text{Rated,c,TABC}}$.

6.7.4 Minimum requirement for single RAT E-UTRA operation

6.7.4.1 General co-location minimum requirement

The transmitter intermodulation level shall not exceed the unwanted emission limits in subclauses 6.6.6, 6.6.5 and 6.6.3 in the presence of an E-UTRA interfering signal according to table 6.7.4.1-1.

The requirement is applicable outside the *Base Station RF Bandwidth* or *Radio Bandwidth*. The interfering signal offset is defined relative to the *Base Station RF Bandwidth edges* or *Radio Bandwidth edges*.

For *TAB connectors* supporting operation in *non-contiguous spectrum*, the requirement is also applicable inside a *sub-block gap* for interfering signal offsets where the interfering signal falls completely within the *sub-block gap*. The interfering signal offset is defined relative to the *sub-block* edges.

For *TAB connectors* supporting operation in multiple operating bands, the requirement applies relative to the *Base Station RF Bandwidth edges* of each supported operating band. In case the inter *Base Station RF Bandwidth gap* is less than 15 MHz, the requirement in the gap applies only for interfering signal offsets where the interfering signal falls completely within the inter *Base Station RF Bandwidth gap*.

The wanted signal and interfering signal centre frequency is specified in table 6.7.4.1-1.

Table 6.7.4.1-1: Interfering and wanted signals for the co-location transmitter intermodulation requirement

Parameter	Value
Wanted signal	E-UTRA single carrier, or multi-carrier, or multiple intra-band contiguously or non-contiguously aggregated carriers
Interfering signal type	E-UTRA signal of <i>channel bandwidth</i> 5 MHz
Interfering signal level	Rated total output power per <i>TAB connector</i> in the operating band ($P_{\text{Rated,t,TABC}}$) – 30dB
Interfering signal centre frequency offset from the lower (upper) edge of the wanted signal or edge of <i>sub-block</i> inside a <i>sub-block gap</i>	$\pm 2,5$ MHz $\pm 7,5$ MHz $\pm 12,5$ MHz
NOTE 1: Interfering signal positions that are partially or completely outside of any <i>downlink operating band</i> of the base station are excluded from the requirement, unless the interfering signal positions fall within the frequency range of adjacent <i>downlink operating bands</i> in the same geographical area. In case that none of the interfering signal positions fall completely within the frequency range of the <i>downlink operating band</i> , 3GPP TS 36.141 [20] provides further guidance regarding appropriate test requirements.	
NOTE 2: In certain regions, note 1 is not applied in Band 1, 3, 8, 9, 11, 18, 19, 21, 28, 32 operating within 1 475.9 MHz to 1 495.9 MHz, 34.	

6.7.4.2 Additional requirement for Band 41

In certain regions the following requirement may apply: For AAS BS in *single RAT E-UTRA operation* operating in band 41 in the presence of an interfering signal according to table 6.7.4.2-1, the transmitter intermodulation level shall not exceed the maximum levels for spurious emission, and operating band unwanted emission specified additionally for operating band 41 *single RAT E-UTRA operation*. Also the ACLR requirements for same carrier type assumed in adjacent channels shall be fulfilled in the presence of the interfering signal.

Table 6.7.4.2-1: Interfering and wanted signals for the additional co-location transmitter intermodulation requirement for Band 41

Parameter	Value
Wanted signal	E-UTRA single carrier (note)
Interfering signal type	E-UTRA signal of the same <i>channel bandwidth</i> as the wanted signal
Interfering signal level	Rated total output power per <i>TAB connector</i> in the operating band ($P_{\text{Rated,t,TABC}}$) – 30dB
Interfering signal centre frequency offset from the centre frequency of the wanted signal	$\pm BW_{\text{Channel}}$ $\pm 2 \times BW_{\text{Channel}}$
NOTE: This requirement applies for 10 MHz or 20 MHz E-UTRA carriers allocated within 2 545 MHz to 2 575 MHz or 2 595 MHz to 2 645 MHz.	

6.7.4.3 Intra-system minimum requirement

The transmitter intermodulation level shall not exceed the unwanted emission limits specified for operating band unwanted emission in subclause 6.6.5 and ACLR in subclause 6.6.3 in the presence of a wanted signal and an interfering signal according to table 6.7.4.3-1 for AAS BS.

Table 6.7.4.3-1: Interfering and wanted signals for intra-system transmitter intermodulation requirement

Parameter	Value
Wanted signal type	E-UTRA
Interfering signal type	E-UTRA signal of the same <i>channel bandwidth</i> as the wanted signal (note 1).
Interfering signal level	Power level declared by the base station manufacturer (note 2).
Frequency offset between interfering signal and wanted signal	0 MHz
NOTE 1: The interfering signal shall be incoherent with the wanted signal.	
NOTE 2: The declared interfering signal power level at each <i>TAB connector</i> is the sum of the co-channel leakage power coupled via the combined RDN and Antenna Array from all the other <i>TAB connectors</i> , but does not comprise power radiated from the Antenna Array and reflected back from the environment. The power at each of the interfering <i>TAB connectors</i> is $P_{\text{Rated,c,TABC}}$.	

7 Conducted receiver characteristics

7.1 General

Unless otherwise stated, the receiver characteristics are specified at the AAS BS *TAB connector* with full complement of transceivers for the configuration in normal operating condition. For FDD operation the requirements in clause 7 shall be met with the transmitter unit(s) on.

NOTE 1: In normal operating condition the BS in FDD operation is configured to transmit and receive at the same time.

NOTE 2: In normal operating condition the BS in TDD operation is configured to TX OFF power during *receive period*.

The manufacturer shall declare the minimum number of supported geographical cells (i.e. geographical areas). The minimum number of supported geographical cells (N_{cells}) relates to the AAS BS setting with minimum amount of cell splitting. The manufacturer shall also declare *TAB connector RX min cell groups* for this minimum number of cells configuration. Every *TAB connector* supporting reception in an operating band shall map to one *TAB connector RX min cell group* supporting the same. The mapping of *TAB connectors* to cells is implementation dependent.

The number of active receiver units that are considered when calculating the emission limit ($N_{\text{RXU,counted}}$) for an AAS BS is calculated as follows:

$N_{\text{RXU,counted}} = \min(N_{\text{RXU,active}}, 8 \times N_{\text{cells}})$ for AAS BS in *single RAT E-UTRA operation* and MSR AAS BS (excluding UTRA only MSR AAS BS).

And

$N_{\text{RXU,counted}} = \min(N_{\text{RXU,active}}, 4 \times N_{\text{cells}})$ for AAS BS in *single RAT UTRA operation* and UTRA only MSR AAS BS.

Further:

$$N_{\text{RXU,countedpercell}} = N_{\text{RXU,counted}} / N_{\text{cells}}$$

$N_{\text{RXU,countedpercell}}$ is used for scaling the *basic limits* as described in subclause 7.6.

NOTE 3: $N_{\text{RXU,active}}$ is the number of actually active receiver units and is independent to the declaration of N_{cells} .

Any receiver requirement specified for NB-IoT in-band, NB-IoT guard band, or standalone NB-IoT operation in 3GPP TS 36.104 [4] for E-UTRA with NB-IoT (in-band or guard band) or for standalone NB-IoT, or in 3GPP TS 37.104 [5] for E-UTRA with NB-IoT or standalone NB-IoT in *MSR operation*, and referred in clause 7, is not applicable for AAS BS.

Any receiver requirement specified for Band 46 operation in 3GPP TS 36.104 [4] for E-UTRA, or in 3GPP TS 37.104 [5] for E-UTRA in *MSR operation*, and referred in clause 6, is not applicable for AAS BS. The requirements for co-location blocking for Band 46 are applicable for AAS BS.

7.2 Reference sensitivity level

7.2.1 General

The reference sensitivity power level P_{REFSENS} is the minimum mean power received at the *TAB connector* at which a reference performance requirement shall be met for a specified reference measurement channel.

7.2.2 Minimum requirement for MSR operation

For UTRA, the minimum requirement for reference sensitivity is specified in subclause 7.2.3.

For E-UTRA, the minimum requirement for reference sensitivity is specified in subclause 7.2.4.

7.2.3 Minimum requirement for single RAT UTRA operation

The single RAT UTRA FDD AAS BS of Wide Area BS class shall fulfil minimum requirements for reference sensitivity specified in 3GPP TS 25.104 [6], subclause 7.2.1.

The single RAT UTRA FDD AAS BS of Medium Range BS class shall fulfil minimum requirements for reference sensitivity specified in 3GPP TS 25.104 [6], subclause 7.2.1.

The single RAT UTRA FDD AAS BS of Local Area BS class shall fulfil minimum requirements for reference sensitivity specified in 3GPP TS 25.104 [6], subclause 7.2.1.

The single RAT UTRA TDD AAS BS of Wide Area BS class shall fulfil minimum requirements for reference sensitivity specified in 3GPP TS 25.105 [7], subclause 7.2.1.1.

The single RAT UTRA TDD AAS BS of Local Area BS class shall fulfil minimum requirements for reference sensitivity specified in 3GPP TS 25.105 [7], subclause 7.2.1.1.

7.2.4 Minimum requirement for single RAT E-UTRA operation

The single RAT E-UTRA AAS BS of Wide Area BS class shall fulfil minimum requirements for reference sensitivity specified in 3GPP TS 36.104 [8], subclause 7.2.1.

The single RAT E-UTRA AAS BS of Medium Range BS class shall fulfil minimum requirements for reference sensitivity specified in 3GPP TS 36.104 [8], subclause 7.2.1.

The single RAT E-UTRA AAS BS of Local Area BS class shall fulfil minimum requirements for reference sensitivity specified in 3GPP TS 36.104 [8], subclause 7.2.1.

7.3 Dynamic range

7.3.1 General

The dynamic range is a measure of the capability of the receiver unit to receive a wanted signal in the presence of an interfering signal at the *TAB connector* inside the received *channel bandwidth* or the capability of receiving high level of wanted signal.

7.3.2 Minimum requirement for MSR operation

For UTRA, the minimum requirement for dynamic range is specified in subclause 7.3.3.

For E-UTRA, the minimum requirement for dynamic range is specified in subclause 7.3.4.

7.3.3 Minimum requirement for single RAT UTRA operation

The single RAT UTRA FDD AAS BS of Wide Area BS class shall fulfil minimum requirements for dynamic range specified in 3GPP TS 25.104 [6], subclause 7.3.1.

The single RAT UTRA FDD AAS BS of Medium Range BS class shall fulfil minimum requirements for dynamic range specified in 3GPP TS 25.104 [6], subclause 7.3.1.

The single RAT UTRA FDD AAS BS of Local Area BS class shall fulfil minimum requirements for dynamic range specified in 3GPP TS 25.104 [6], subclause 7.3.1.

The single RAT UTRA TDD AAS BS of Wide Area BS class shall fulfil minimum requirements for dynamic range specified in 3GPP TS 25.105 [7], subclause 7.3.1.1.

The single RAT UTRA TDD AAS BS of Local Area BS class shall fulfil minimum requirements for dynamic range specified in 3GPP TS 25.105 [7], subclause 7.3.1.1.

7.3.4 Minimum requirement for single RAT E-UTRA operation

The single RAT E-UTRA AAS BS of Wide Area BS class shall fulfil minimum requirements for dynamic range specified in 3GPP TS 36.104 [8], subclause 7.3.1.

The single RAT E-UTRA AAS BS of Medium Range BS class shall fulfil minimum requirements for dynamic range specified in 3GPP TS 36.104 [8], subclause 7.3.1.

The single RAT E-UTRA AAS BS of Local Area BS class shall fulfil minimum requirements for dynamic range specified in 3GPP TS 36.104 [8], subclause 7.3.1.

7.4 Adjacent channel selectivity, general blocking, and narrowband blocking

7.4.1 General

The adjacent channel selectivity (ACS), general blocking and narrowband blocking characteristics are measures of the receiver unit ability to receive a wanted signal at its assigned channel at the *TAB connector* in the presence of an unwanted interferer inside the operating band.

NOTE: For Single RAT requirements, the in-band selectivity characteristics is referred to as "adjacent channel selectivity", whereas for the MSR requirements, the corresponding property is referred to as "general blocking" since the adjacent frequency range may not carry a channel addressable from the interfered carrier.

7.4.2 Minimum requirement for MSR operation

7.4.2.1 General minimum requirement

For the general blocking requirement, the interfering signal shall be a UTRA FDD signal as specified in 3GPP TS 37.104 [9], annex A.1.

The requirement is applicable outside the *Base Station RF Bandwidth* or *Radio Bandwidth*. The interfering signal offset is defined relative to the *Base Station RF Bandwidth edges* or *Radio Bandwidth edges* applicable to each *TAB connector*.

For *TAB connector* supporting operation in *non-contiguous spectrum*, the requirement applies in addition inside any *sub-block gap*, in case the *sub-block gap* size is at least 15 MHz. The interfering signal offset is defined relative to the *sub-block edges* inside the *sub-block gap*.

For *multi-band TAB connectors*, the requirement applies in addition inside any *Inter RF Bandwidth gap* at those connectors, in case the gap size is at least 15 MHz. The interfering signal offset is defined relative to the *Base Station RF Bandwidth edges* inside the *Inter RF Bandwidth gap*.

For the wanted and interfering signal coupled to the *TAB connector*, using the parameters in tables 7.4.2.1-1 and 7.4.2.1-2, the following requirements shall be met:

- For any E-UTRA carrier, the throughput shall be ≥ 95 % of the *maximum throughput* of the reference measurement channel defined in 3GPP TS 36.104 [8], subclause 7.2.1.
- For any UTRA FDD carrier, the BER shall not exceed 0,001 for the reference measurement channel defined in 3GPP TS 25.104 [6], subclause 7.2.1.
- For any UTRA TDD carrier, the BER shall not exceed 0,001 for the reference measurement channel defined in 3GPP TS 25.105 [7], subclause 7.2.1.2.

For *multi-band TAB connectors*, the requirement applies according to table 7.4.2.1-1 at those connectors for the in-band blocking frequency ranges of each supported operating band.

Table 7.4.2.1-1: General blocking requirement

Base Station Type	Mean power of interfering signal (dBm)	Wanted Signal mean power (dBm) (NOTE 1)	Centre Frequency of Interfering Signal	Interfering signal centre frequency minimum frequency offset from the Base Station RF Bandwidth edge or edge of sub-block inside a gap (MHz)
Wide Area BS	-40	$P_{\text{REFSENS}} + x$ dB (note 2)	See table 7.4.2.1-2	± 7.5
Medium Range BS	-35	$P_{\text{REFSENS}} + x$ dB (note 3)		
Local Area BS	-30	$P_{\text{REFSENS}} + x$ dB (note 4)		
NOTE 1: P_{REFSENS} depends on the RAT, the BS class and on the <i>channel bandwidth</i> , see subclause 7.2.2. NOTE 2: For Wide Area BS, "x" is equal to 6 dB in case of E-UTRA or UTRA wanted signals. NOTE 3: For Medium Range BS, "x" is equal to 9 dB in case of E-UTRA wanted signals, 6 dB in case of UTRA wanted signal. NOTE 4: For Local Area BS, "x" is equal to 11 dB in case of E-UTRA wanted signal, 6 dB in case of UTRA wanted signal. NOTE 5: For <i>multi-band TAB connectors</i> , "x" in notes 2, 3, 4 apply in case of interfering signals that are in the in-band blocking frequency range of the operating band where the wanted signal is present, or in an adjacent or overlapping band. For other in-band blocking frequency ranges of the interfering signal for the supported operating band, "x" is equal to 1.4 dB.				

Table 7.4.2.1-2: Interfering signal for the general blocking requirement

Operating Band Number	Centre Frequency of Interfering Signal (MHz)
1-7, 9-11, 13, 14, 18, 19, 21-23, 24, 27, 30, 33-45, 65, 66, 68	$(F_{\text{UL_low}} - 20)$ to $(F_{\text{UL_high}} + 20)$
8, 26, 28	$(F_{\text{UL_low}} - 20)$ to $(F_{\text{UL_high}} + 10)$
12	$(F_{\text{UL_low}} - 20)$ to $(F_{\text{UL_high}} + 13)$
17	$(F_{\text{UL_low}} - 20)$ to $(F_{\text{UL_high}} + 18)$
20	$(F_{\text{UL_low}} - 11)$ to $(F_{\text{UL_high}} + 20)$
25	$(F_{\text{UL_low}} - 20)$ to $(F_{\text{UL_high}} + 15)$
31	$(F_{\text{UL_low}} - 20)$ to $(F_{\text{UL_high}} + 5)$

NOTE: The requirement in tables 7.4.2.1-1 and 7.4.2.1-2 assumes that two operating bands, where the *downlink operating band* (see subclause 4.5 in 3GPP TS 37.104 [9]) of one band would be within the in-band blocking region of the other band, are not deployed in the same geographical area.

7.4.2.2 General narrowband blocking minimum requirement

For the general narrowband blocking requirement, the interfering signal shall be an E-UTRA 1RB signal as specified in 3GPP TS 37.104 [9], annex A.3.

The requirement is applicable outside the *Base Station RF Bandwidth* or *Radio Bandwidth*. The interfering signal offset is defined relative to the *Base Station RF Bandwidth edges* or *Radio Bandwidth edges*.

For *TAB connectors* supporting operation in *non-contiguous spectrum*, the requirement applies in addition inside any *sub-block gap*, in case the *sub-block gap* size is at least 3 MHz. The interfering signal offset is defined relative to the *sub-block edges* inside the *sub-block gap*.

For *multi-band TAB connectors*, the requirement applies in addition inside any *Inter RF Bandwidth gap* at those connectors, in case the gap size is at least 3 MHz. The interfering signal offset is defined relative to the *Base Station RF Bandwidth edges* inside the *Inter RF Bandwidth gap*.

For the wanted and interfering signal coupled to the *TAB connector* using the parameters in Table 7.4.2.2-1, the following requirements shall be met:

- For any E-UTRA carrier, the throughput shall be ≥ 95 % of the *maximum throughput* of the reference measurement channel defined in 3GPP TS 36.104 [8], subclause 7.2.1.
- For any UTRA FDD carrier, the BER shall not exceed 0,001 for the reference measurement channel defined in 3GPP TS 25.104 [6], subclause 7.2.1.
- For any UTRA TDD carrier, the BER shall not exceed 0,001 for the reference measurement channel defined in 3GPP TS 25.105 [7], subclause 7.2.1.2.

Table 7.4.2.2-1: Narrowband blocking requirement

Base Station Type	RAT of the carrier	Wanted signal mean power (dBm) (NOTE 1)	Interfering signal mean power (dBm)	Interfering RB (NOTE 3) centre frequency offset from the AAS <i>Base Station RF Bandwidth edge</i> or <i>edge of sub-block</i> inside a gap [kHz]
Wide Area BS	E-UTRA, UTRA	$P_{\text{REFSENS}} + x$ dB (NOTE 2)	-49	$\pm(240 + m \cdot 180)$, $m=0, 1, 2, 3, 4, 9, 14$
Medium Range BS			-44	
Local Area BS			-41	
NOTE 1: P_{REFSENS} depends on the RAT, the AAS BS class and on the <i>channel bandwidth</i> , see subclause 7.2.2. NOTE 2: "x" is equal to 6 dB in case of E-UTRA or UTRA wanted signals. NOTE 3: Interfering signal (E-UTRA 3 MHz) consisting of one resource block positioned at the stated offset, the <i>channel bandwidth</i> of the interfering signal is located adjacently to the AAS <i>Base Station RF Bandwidth edge</i> .				

7.4.2.3 Additional BC3 blocking minimum requirement

For the additional BC3 blocking requirement, the interfering signal is a 1,28 Mcps UTRA TDD signal as specified in 3GPP TS 37.104 [9], annex A.2.

The requirement is always applicable outside the *Base Station RF Bandwidth* or *Radio Bandwidth*. The interfering signal offset is defined relative to the *Base Station RF Bandwidth edges* or *Radio Bandwidth edges*.

For *multi-band TAB connectors*, the requirement applies in addition inside any *Inter RF Bandwidth gap* at those connectors, in case the gap size is at least 4.8 MHz. The interfering signal offset is defined relative to the *Base Station RF Bandwidth edges* inside the *Inter RF Bandwidth gap*.

For the wanted and interfering signal coupled to the *TAB connector*, using the parameters in Table 7.4.2.3-1, the following requirements shall be met:

- For any E-UTRA TDD carrier, the throughput shall be ≥ 95 % of the *maximum throughput* of the reference measurement channel defined in 3GPP TS 36.104 [8], subclause 7.2.1.

- For any UTRA TDD carrier, the BER shall not exceed 0,001 for the reference measurement channel defined in 3GPP TS 25.105 [7], subclause 7.2.1.2.

Table 7.4.2.3-1: Additional blocking requirement for BC3

Operating Band	Centre Frequency of Interfering Signal (MHz)	Interfering Signal mean power (dBm)	Wanted Signal mean power (dBm)	Interfering signal centre frequency minimum frequency offset from the Base Station RF Bandwidth edge (MHz)
33 - 40	(F _{UL_low} - 20) to (F _{UL_high} + 20)	-40	P _{REFSENS} + 6 dB (NOTE)	±2,4
NOTE: P _{REFSENS} depends on the RAT and on the <i>channel bandwidth</i> , see subclause 7.2.2.				

7.4.3 Minimum requirement for single RAT UTRA operation

The single RAT UTRA FDD AAS BS of Wide Area BS class shall fulfil minimum requirements for ACS and narrowband blocking specified in 3GPP TS 25.104 [6], subclause 7.4.

The single RAT UTRA FDD AAS BS of Medium Range BS class shall fulfil minimum requirements for ACS and narrowband blocking specified in 3GPP TS 25.104 [6], subclause 7.4.

The single RAT UTRA FDDv Local Area BS class shall fulfil minimum requirements for ACS and narrowband blocking specified in 3GPP TS 25.104 [6], subclause 7.4.

The single RAT UTRA TDD AAS BS of Wide Area BS class shall fulfil minimum requirements for ACS and narrowband blocking specified in 3GPP TS 25.105 [7], subclause 7.4.

The single RAT UTRA TDD AAS BS of Local Area BS class shall fulfil minimum requirements for ACS and narrowband blocking specified in 3GPP TS 25.105 [7], subclause 7.4.

7.4.4 Minimum requirement for single RAT E-UTRA operation

The single RAT E-UTRA AAS BS of Wide Area BS class shall fulfil minimum requirements for ACS and narrowband blocking specified in 3GPP TS 36.104 [8], subclause 7.5.

The single RAT E-UTRA AAS BS of Medium Range BS class shall fulfil minimum requirements for ACS and narrowband blocking specified in 3GPP TS 36.104 [8], subclause 7.5.

The single RAT E-UTRA AAS BS of Local Area BS class shall fulfil minimum requirements for ACS and narrowband blocking specified in 3GPP TS 36.104 [8], subclause 7.5.

7.5 Blocking

7.5.1 General

The blocking characteristics are a measure of the receiver unit ability to receive a wanted signal at the *TAB connector* at its assigned channel in the presence of an unwanted interferer.

7.5.2 Minimum requirement for MSR operation

7.5.2.1 General minimum requirement

For a wanted and an interfering signal coupled to the *TAB connector* using the parameters in table 7.5.2.1-1, the following requirements shall be met:

- For any E-UTRA carrier, the throughput shall be ≥ 95 % of the *maximum throughput* of the reference measurement channel defined in 3GPP TS 36.104 [8], subclause 7.2.1.
- For any UTRA FDD carrier, the BER shall not exceed 0,001 for the reference measurement channel defined in 3GPP TS 25.104 [6], subclause 7.2.1.
- For any UTRA TDD carrier, the BER shall not exceed 0,001 for the reference measurement channel defined in 3GPP TS 25.105 [7], subclause 7.2.1.2.

For *multi-band TAB connectors*, the requirement applies for each supported operating band. The in-band blocking frequency ranges of all supported operating bands according to Table 7.4.2.1-1 shall be excluded from the requirement.

Table 7.5.2.1-1: Blocking performance requirement

Operating Band Number	Centre Frequency of Interfering Signal (MHz)	Interfering Signal mean power (dBm)	Wanted Signal mean power (dBm)	Type of Interfering Signal
1-7, 9-11, 13, 14, 18, 19, 21-23, 24, 27, 30, 33-45, 65, 66, 68	1 to (F _{UL_low} -20) (F _{UL_high} +20) to 12750	-15	P _{PREFSENS} + x dB (NOTE)	CW carrier
8, 26, 28	1 to (F _{UL_low} -20) (F _{UL_high} +10) to 12750	-15	P _{PREFSENS} + x dB (NOTE)	CW carrier
12	1 to (F _{UL_low} -20) (F _{UL_high} +13) to 12750	-15	P _{PREFSENS} + x dB (NOTE)	CW carrier
17	1 to (F _{UL_low} -20) (F _{UL_high} +18) to 12750	-15	P _{PREFSENS} + x dB (NOTE)	CW carrier
20	1 to (F _{UL_low} -11) (F _{UL_high} +20) to 12750	-15	P _{PREFSENS} + x dB (NOTE)	CW carrier
25	1 to (F _{UL_low} -20) (F _{UL_high} +15) to 12750	-15	P _{PREFSENS} + x dB (NOTE)	CW carrier
31	1 to (F _{UL_low} -20) (F _{UL_high} +5) to 12750	-15	P _{PREFSENS} + x dB (NOTE)	CW carrier
NOTE: P _{PREFSENS} depends on the RAT, the BS class and the <i>channel bandwidth</i> , see subclause 7.2.2. "x" is equal to 6 dB in case of E-UTRA or UTRA wanted signals.				

7.5.2.2 Co-location minimum requirement

This additional blocking requirement may be applied for the protection of AAS BS receivers when E-UTRA BS, UTRA BS, CDMA BS or GSM/EDGE BS operating in a different frequency band are co-located with an AAS BS.

The requirements in this subclause assume a 30 dB coupling loss between the interfering transmitter and the AAS BS receiver and are based on co-location with base stations of the same class.

For a wanted and an interfering signal coupled to the *TAB connector* using the parameters in table 7.5.2.2-1, the following requirements shall be met:

- For any E-UTRA carrier, the throughput shall be ≥ 95 % of the *maximum throughput* of the reference measurement channel defined in 3GPP TS 36.104 [8], subclause 7.2.1.
- For any UTRA FDD carrier, the BER shall not exceed 0,001 for the reference measurement channel defined in 3GPP TS 25.104 [6], subclause 7.2.1.
- For any UTRA TDD carrier, the BER shall not exceed 0,001 for the reference measurement channel defined in 3GPP TS 25.105 [7], subclause 7.2.1.2.

Table 7.5.2.2-1: Blocking requirement for co-location with BS in other frequency bands

Type of co-located BS	Centre Frequency of Interfering Signal (MHz)	Interfering Signal mean power for WA BS (dBm)	Interfering Signal mean power for MR BS (dBm)	Interfering Signal mean power for LA BS (dBm)	Wanted Signal mean power (dBm)	Type of Interfering Signal
GSM850 or CDMA850	869 - 894	+16	+8	-6	$P_{\text{REFSENS}} + x$ dB (note 1)	CW carrier
GSM900	921 - 960	+16	+8	-6	$P_{\text{REFSENS}} + x$ dB (note 1)	CW carrier
DCS1800	1 805 - 1 880 (note 4)	+16	+8	-6	$P_{\text{REFSENS}} + x$ dB (note 1)	CW carrier
PCS1900	1 930 - 1 990	+16	+8	-6	$P_{\text{REFSENS}} + x$ dB (note 1)	CW carrier
UTRA FDD Band I or E-UTRA Band 1	2 110 - 2 170	+16	+8	-6	$P_{\text{REFSENS}} + x$ dB (note 1)	CW carrier
UTRA FDD Band II or E-UTRA Band 2	1 930 - 1 990	+16	+8	-6	$P_{\text{REFSENS}} + x$ dB (note 1)	CW carrier
UTRA FDD Band III or E-UTRA Band 3	1 805 - 1 880 (note 4)	+16	+8	-6	$P_{\text{REFSENS}} + x$ dB (note 1)	CW carrier
UTRA FDD Band IV or E-UTRA Band 4	2 110 - 2 155	+16	+8	-6	$P_{\text{REFSENS}} + x$ dB (note 1)	CW carrier
UTRA FDD Band V or E-UTRA Band 5	869 - 894	+16	+8	-6	$P_{\text{REFSENS}} + x$ dB (note 1)	CW carrier
UTRA FDD Band VI or E-UTRA Band 6	875 - 885	+16	+8	-6	$P_{\text{REFSENS}} + x$ dB (note 1)	CW carrier
UTRA FDD Band VII or E-UTRA Band 7	2 620 - 2 690	+16	+8	-6	$P_{\text{REFSENS}} + x$ dB (note 1)	CW carrier
UTRA FDD Band VIII or E-UTRA Band 8	925 - 960	+16	+8	-6	$P_{\text{REFSENS}} + x$ dB (note 1)	CW carrier
UTRA FDD Band IX or E-UTRA Band 9	1 844.9 - 1 879.9	+16	+8	-6	$P_{\text{REFSENS}} + x$ dB (note 1)	CW carrier
UTRA FDD Band X or E-UTRA Band 10	2 110 - 2 170	+16	+8	-6	$P_{\text{REFSENS}} + x$ dB (note 1)	CW carrier
UTRA FDD Band XI or E-UTRA Band 11	1 475.9 - 1 495.9	+16	+8	-6	$P_{\text{REFSENS}} + x$ dB (note 1)	CW carrier
UTRA FDD Band XII or E-UTRA Band 12	729 - 746	+16	+8	-6	$P_{\text{REFSENS}} + x$ dB (note 1)	CW carrier
UTRA FDD Band XIII or E-UTRA Band 13	746 - 756	+16	+8	-6	$P_{\text{REFSENS}} + x$ dB (note 1)	CW carrier
UTRA FDD Band XIV or E-UTRA Band 14	758 - 768	+16	+8	-6	$P_{\text{REFSENS}} + x$ dB (note 1)	CW carrier
E-UTRA Band 17	734 - 746	+16	+8	-6	$P_{\text{REFSENS}} + x$ dB (note 1)	CW carrier
E-UTRA Band 18	860 - 875	+16	+8	-6	$P_{\text{REFSENS}} + x$ dB (note 1)	CW carrier
UTRA FDD Band XIX or E-UTRA Band 19	875 - 890	+16	+8	-6	$P_{\text{REFSENS}} + x$ dB (note 1)	CW carrier
UTRA FDD Band XX or E-UTRA Band 20	791 - 821	+16	+8	-6	$P_{\text{REFSENS}} + x$ dB (note 1)	CW carrier
UTRA FDD Band XXI or E-UTRA Band 21	1 495.9 - 1 510.9	+16	+8	-6	$P_{\text{REFSENS}} + x$ dB (note 1)	CW carrier
UTRA FDD Band XXII or E-UTRA Band 22	3 510 - 3 590	+16	+8	-6	$P_{\text{REFSENS}} + x$ dB (note 1)	CW carrier
E-UTRA Band 23	2 180 - 2 200	+16	+8	-6	$P_{\text{REFSENS}} + x$ dB (note 1)	CW carrier
E-UTRA Band 24	1 525 - 1 559	+16	+8	-6	$P_{\text{REFSENS}} + x$ dB (note 1)	CW carrier
UTRA FDD Band XXV or E-UTRA Band 25	1 930 - 1 995	+16	+8	-6	$P_{\text{REFSENS}} + x$ dB (note 1)	CW carrier
UTRA FDD Band XXVI or E-UTRA Band 26	859 - 894	+16	+8	-6	$P_{\text{REFSENS}} + x$ dB (note 1)	CW carrier

Type of co-located BS	Centre Frequency of Interfering Signal (MHz)	Interfering Signal mean power for WA BS (dBm)	Interfering Signal mean power for MR BS (dBm)	Interfering Signal mean power for LA BS (dBm)	Wanted Signal mean power (dBm)	Type of Interfering Signal
E-UTRA Band 27	852 - 869	+16	+8	-6	$P_{\text{REFSENS}} + x \text{ dB}$ (note 1)	CW carrier
E-UTRA Band 28	758 - 803	+16	+8	-6	$P_{\text{REFSENS}} + x \text{ dB}$ (note 1)	CW carrier
E-UTRA Band 29	717 - 728	+16	+8	-6	$P_{\text{REFSENS}} + 6 \text{ dB}$ (note 1)	CW carrier
E-UTRA Band 30	2 350 - 2 360	+16	+8	-6	$P_{\text{REFSENS}} + x \text{ dB}$ (note 1)	CW carrier
E-UTRA Band 31	462.5 - 467.5	+16	+8	-6	$P_{\text{REFSENS}} + 6 \text{ dB}$ (note 1)	CW carrier
UTRA FDD Band XXXII or E-UTRA Band 32	1 452 - 1 496 (note-5)	+16	+8	-6	$P_{\text{REFSENS}} + 6 \text{ dB}$ (note 1)	CW carrier
UTRA TDD Band a) or E-UTRA TDD Band 33	1 900 - 1 920	+16	+8	-6	$P_{\text{REFSENS}} + x \text{ dB}$ (note 1)	CW carrier
UTRA TDD Band a) or E-UTRA TDD Band 34	2 010 - 2 025	+16	+8	-6	$P_{\text{REFSENS}} + x \text{ dB}$ (note 1)	CW carrier
UTRA TDD Band b) or E-UTRA TDD Band 35	1 850 - 1 910	+16	+8	-6	$P_{\text{REFSENS}} + x \text{ dB}$ (note 1)	CW carrier
UTRA TDD Band b) or E-UTRA TDD Band 36	1 930 - 1 990	+16	+8	-6	$P_{\text{REFSENS}} + x \text{ dB}$ (note 1)	CW carrier
UTRA TDD Band c) or E-UTRA TDD Band 37	1 910 - 1 930	+16	+8	-6	$P_{\text{REFSENS}} + x \text{ dB}$ (note 1)	CW carrier
UTRA TDD Band d) or E-UTRA Band 38	2 570 - 2 620	+16	+8	-6	$P_{\text{REFSENS}} + x \text{ dB}$ (note 1)	CW carrier
UTRA TDD Band f) or E-UTRA Band 39	1 880 - 1 920	+16	+8	-6	$P_{\text{REFSENS}} + x \text{ dB}$ (note 1)	CW carrier
UTRA TDD Band e) or E-UTRA Band 40	2 300 - 2 400	+16	+8	-6	$P_{\text{REFSENS}} + x \text{ dB}$ (note 1)	CW carrier
E-UTRA Band 41	2 496 - 2 690	+16	+8	-6	$P_{\text{REFSENS}} + x \text{ dB}$ (note1)	CW carrier
E-UTRA Band 42	3 400 - 3 600	+16	+8	-6	$P_{\text{REFSENS}} + x \text{ dB}$ (note 1)	CW carrier
E-UTRA Band 43	3 600 - 3 800	+16	+8	-6	$P_{\text{REFSENS}} + x \text{ dB}$ (note 1)	CW carrier
E-UTRA Band 44	703 - 803	+16	+8	-6	$P_{\text{REFSENS}} + x \text{ dB}$ (note 1)	CW carrier
E-UTRA Band 45	1447 - 1467	+16	+8	-6	$P_{\text{REFSENS}} + x \text{ dB}$ (note 1)	CW carrier
E-UTRA Band 46	5150 - 5925	N/A	+8	-6	$P_{\text{REFSENS}} + x \text{ dB}$ (note 1)	CW carrier
E-UTRA Band 65	2110 – 2200	+16	+8	-6	$P_{\text{REFSENS}} + x \text{ dB}$ (note 1)	CW carrier
E-UTRA Band 66	2110 – 2200	+16	+8	-6	$P_{\text{REFSENS}} + x \text{ dB}$ (note 1)	CW carrier
E-UTRA Band 67	738 - 758	+16	+8	-6	$P_{\text{REFSENS}} + x \text{ dB}$ (note 1)	CW carrier
E-UTRA Band 68	753 - 783	+16	+8	-6	$P_{\text{REFSENS}} + x \text{ dB}$ (note 1)	CW carrier

Type of co-located BS	Centre Frequency of Interfering Signal (MHz)	Interfering Signal mean power for WA BS (dBm)	Interfering Signal mean power for MR BS (dBm)	Interfering Signal mean power for LA BS (dBm)	Wanted Signal mean power (dBm)	Type of Interfering Signal
NOTE 1: P_{REFSENS} depends on the RAT, the BS class and the <i>channel bandwidth</i> , see subclause 7.2.2. "x" is equal to 6 dB in case of UTRA or E-UTRA wanted signals.						
NOTE 2: Except for a BS operating in Band 13, these requirements do not apply when the interfering signal falls within any of the supported <i>uplink operating band</i> or in the 10 MHz immediately outside any of the supported <i>uplink operating band</i> . For a BS operating in band 13 the requirements do not apply when the interfering signal falls within the frequency range 768 - 797 MHz.						
NOTE 3: Some combinations of bands may not be possible to co-site based on the requirements above. The current state-of-the-art technology does not allow a single generic solution for co-location of UTRA TDD or E-UTRA TDD with E-UTRA FDD on adjacent frequencies for 30dB BS-BS minimum coupling loss. However, there are certain site-engineering solutions that can be used. These techniques are addressed in 3GPP TR 25.942 [12].						
NOTE 4: In China, the blocking requirement for co-location with DCS1800 and Band III BS is only applicable in the frequency range 1 805 - 1 850 MHz.						
NOTE 5: For an AAS BS operating in band 11 or 21, this requirement applies for interfering signal within the frequency range 1 475.9 - 1 495.9 MHz.						
NOTE 6: Co-located TDD base stations that are synchronized and using the same or adjacent operating band can receive without special co-location requirements. For unsynchronized base stations, special co-location requirements may apply that are not covered by the 3GPP specifications.						

7.5.3 Minimum requirement for single RAT UTRA operation

7.5.3.1 General minimum requirement

The single RAT UTRA FDD AAS BS of Wide Area BS class shall fulfil minimum requirements for blocking specified in 3GPP TS 25.104 [6], subclause 7.5.1.

The single RAT UTRA FDD AAS BS of Medium Range BS class shall fulfil minimum requirements for blocking specified in 3GPP TS 25.104 [6], subclause 7.5.1.

The single RAT UTRA FDD AAS BS of Local Area BS class shall fulfil minimum requirements for blocking specified in 3GPP TS 25.104 [6], subclause 7.5.1.

The single RAT UTRA 1,28 Mcps TDD AAS BS of Wide Area BS class shall fulfil minimum requirements for blocking specified in 3GPP TS 25.105 [7], subclause 7.5.0.2.

The single RAT UTRA 1,28 Mcps TDD AAS BS of Local Area BS class shall fulfil minimum requirements for blocking specified in 3GPP TS 25.105 [7], subclause 7.5.0.2.

7.5.3.2 Co-location minimum requirement

The single RAT UTRA FDD AAS BS of Wide Area BS class may optionally fulfil minimum requirements for co-location blocking specified in 3GPP TS 25.104 [6], subclause 7.5.2.

The single RAT UTRA FDD AAS BS of Medium Range BS class may optionally fulfil minimum requirements for co-location blocking specified in 3GPP TS 25.104 [6], subclause 7.5.2.

The single RAT UTRA FDD AAS BS of Local Area BS class may optionally fulfil minimum requirements for co-location blocking specified in 3GPP TS 25.104 [6], subclause 7.5.2.

The single RAT UTRA 1,28 Mcps TDD AAS BS of Wide Area BS class may optionally fulfil minimum requirements for co-location blocking specified in 3GPP TS 25.105 [7], subclause 7.5.1.2.

The single RAT UTRA 1,28 Mcps TDD AAS BS of Local Area BS class may optionally fulfil minimum requirements for co-location blocking specified in 3GPP TS 25.105 [7], subclause 7.5.1.2.

7.5.4 Minimum requirement for single RAT E-UTRA operation

7.5.4.1 General minimum requirement

The single RAT E-UTRA AAS BS of Wide Area BS class shall fulfil minimum requirements for blocking specified in 3GPP TS 36.104 [8], subclause 7.6.1.

The single RAT E-UTRA AAS BS of Medium Range BS class shall fulfil minimum requirements for blocking specified in 3GPP TS 36.104 [8], subclause 7.6.1.

The single RAT E-UTRA AAS BS of Local Area BS class shall fulfil minimum requirements for blocking specified in 3GPP TS 36.104 [8], subclause 7.6.1.

7.5.4.2 Co-location minimum requirement

The single RAT E-UTRA AAS BS of Wide Area BS class may optionally fulfil minimum requirements for co-location blocking specified in 3GPP TS 36.104 [8], subclause 7.6.2.

The single RAT E-UTRA AAS BS of Medium Range BS class may optionally fulfil minimum requirements for co-location blocking specified in 3GPP TS 36.104 [8], subclause 7.6.2.

The single RAT E-UTRA AAS BS of Local Area BS class may optionally fulfil minimum requirements for co-location blocking specified in 3GPP TS 36.104 [8], subclause 7.6.2.

7.6 Receiver spurious emissions

7.6.1 General

The receiver spurious emissions power is the power of emissions generated or amplified in a receiver unit that appear at the *TAB connector*. The requirements apply to all AAS BS with separate RX and TX *TAB connectors*.

NOTE: In this case for FDD AAS BS the test is performed when both TX and RX are ON, with the TX *TAB connector* terminated.

For a *TAB connector* supporting both RX and TX in TDD, the requirements apply during the *transmitter OFF period*. For a *TAB connector* supporting both RX and TX in FDD, the receiver spurious requirements are superseded by the TX spurious requirements in subclause 6.6.6.

For RX only *multi-band TAB connector(s)*, the RX spurious emissions requirements are subject to exclusion zones in each supported operating band. For *multi-band TAB connector(s)* that both transmit and receive in operating band supporting TDD, RX spurious emissions requirements are applicable during the TX OFF period, and are subject to exclusion zones in each supported operating band. The unwanted emission level limit of a *TAB connector RX min cell group* is in general defined by the unwanted emission *basic limit* which is the same as the corresponding applicable *non-AAS BS* per transmitter requirement specified in 3GPP TS 25.104 [2], 3GPP TS 25.105 [3], 3GPP TS 36.104 [4] or 3GPP TS 37.104 [5], and its scaling by $N_{\text{RXU, counted per cell}}$. The *basic limits* and corresponding scaling are defined in each relevant subclause. The receiver spurious emission requirements are applied per the *TAB connector RX min cell groups* for all the configurations supported by the AAS BS.

7.6.2 Minimum requirement for MSR operation

7.6.2.1 General minimum requirement

The general MSR RX spurious emission *basic limits* are provided in table 7.6.2.1-1.

Table 7.6.2.1-1: General spurious emissions *basic limits*

Frequency range	Maximum level	Measurement bandwidth	Note
30MHz - 1 GHz	-57 dBm	100 kHz	
1 GHz - 12.75 GHz	-47 dBm	1 MHz	
12.75 GHz - 5 th harmonic of the upper frequency edge of the UL operating band in GHz	-47 dBm	1 MHz	Applies only for Bands 22, 42 and 43.
NOTE: The frequency range from $F_{\text{BW RF,DL,low}} - 10 \text{ MHz}$ to $F_{\text{BW RF,DL,high}} + 10 \text{ MHz}$ may be excluded from the requirement. For <i>multi-band TAB connectors</i> , the exclusion applies for all supported operating bands for those connectors.			

The RX spurious emissions requirements for an MSR AAS BS are that for each applicable *basic limit* specified in table 7.6.2.1-1 for each *TAB connector RX min cell group*, the power sum of emissions at the *TAB connectors* of the *TAB connector RX min cell group* shall not exceed an AAS limit specified as the *basic limits* + $10\log_{10}(N_{\text{RXU,countedpercell}})$.

In addition to the *basic limits* in Table 7.6.2.1-1, additional spurious emissions requirements in 3GPP TS 37.104 [9], subclause 6.6.1.3 form *basic limits* for additional receiver spurious emission requirements.

In case of FDD BS (for BC1 and BC2), the levels specified for Protection of the BS receivers of own or different BS in 3GPP TS 37.104 [9], subclause 6.6.1.2 form basic levels for additional receiver spurious emission requirements.

In addition, the requirements for co-location with other base stations specified in TS37.104 [9], subclause 6.6.1.4 may also form basic levels for co-location spurious emission requirements.

NOTE: Conformance to the AAS BS receiver spurious emissions requirement can be demonstrated by meeting at least one of the following criteria as determined by the manufacturer:

- 1) The sum of the emissions power measured on each *TAB connector* in the *TAB connector RX min cell group* shall be less than or equal to the AAS limit as defined above for the respective frequency span.

Or

- 2) The spurious emission power at each *TAB connector* shall be less than or equal to the AAS limit as defined above for the respective frequency span, scaled by $-10\log_{10}(n)$, where n is the number of *TAB connectors* in the *TAB connector RX min cell group*.

7.6.3 Minimum requirement for single RAT UTRA operation

The single RAT UTRA FDD wide area, medium range area and local area RX spurious emissions *basic limits* are the same as those specified in 3GPP TS 25.104 [6], subclause 7.7.1.

The single RAT UTRA TDD wide area and local area RX spurious emissions *basic limits* are the same as those specified in 3GPP TS 25.105 [7], subclause 7.7.1.2.

The RX spurious emissions requirements for a single RAT UTRA AAS BS are that for each applicable *basic limit* as specified in 3GPP TS 25.104 [6] or 3GPP TS 25.105 [7], for each *TAB connector RX min cell group*, the power sum of emissions at the *TAB connectors* of the *TAB connector RX min cell group* shall not exceed an AAS limit specified as the *basic limits* + $10\log_{10}(N_{\text{RXU,countedpercell}})$.

NOTE: Conformance to the AAS BS receiver spurious emissions requirement can be demonstrated by meeting at least one of the following criteria as determined by the manufacturer:

- 1) The sum of the emissions power measured on each *TAB connector* in the *TAB connector RX min cell group* shall be less than or equal to the AAS limit as defined above for the respective frequency span.

Or

- 2) The spurious emission power at each *TAB connector* shall be less than or equal to the AAS limit as defined above for the respective frequency span, scaled by $-10\log_{10}(n)$, where n is the number of *TAB connectors* in the *TAB connector RX min cell group*.

7.6.4 Minimum requirement for single RAT E-UTRA operation

The single RAT E-UTRA wide area, medium range area and local area RX spurious emissions *basic limits* are the same as those specified in 3GPP TS 36.104 [8], subclause 7.7.1.

The RX spurious emissions requirements for a single RAT E-UTRA AAS BS are that for each applicable *basic limit* specified in 3GPP TS 36.104 [4] for each *TAB connector RX min cell group*, the power sum of emissions at the *TAB connectors* of the *TAB connector RX min cell group* shall not exceed an AAS limit specified as the *basic limits* + $10\log_{10}(N_{RXU, \text{counted per cell}})$.

NOTE: Conformance to the *AAS BS receiver* spurious emissions requirement can be demonstrated by meeting at least one of the following criteria as determined by the manufacturer:

- 1) The sum of the emissions power measured on each *TAB connector* in the *TAB connector RX min cell group* shall be less than or equal to the AAS limit as defined above for the respective frequency span.

Or

- 2) The spurious emission power at each *TAB connector* shall be less than or equal to the AAS limit as defined above for the respective frequency span, scaled by $-10\log_{10}(n)$, where n is the number of *TAB connectors* in the *TAB connector RX min cell group*.

7.7 Receiver intermodulation

7.7.1 General

Third and higher order mixing of the two interfering RF signals can produce an interfering signal in the band of the desired channel. Intermodulation response rejection is a measure of the capability of the receiver unit to receive a wanted signal on its assigned channel frequency in the presence of two interfering signals which have a specific frequency relationship to the wanted signal. The requirement applies per *TAB connector*.

7.7.2 Minimum requirement for MSR operation

7.7.2.1 General intermodulation minimum requirement

Interfering signals shall be a CW signal and an E-UTRA or UTRA signal as specified in 3GPP TS 37.104 [9], annex A.

The requirement is applicable outside the *Base Station RF Bandwidth* or *Radio Bandwidth*. The interfering signal offset is defined relative to the *Base Station RF Bandwidth edges* or *Radio Bandwidth edges*.

For *multi-band TAB connectors*, the requirement applies in addition inside any *Inter RF Bandwidth gap* at those connectors, in case the gap size is at least twice as wide as the UTRA/E-UTRA interfering signal centre frequency offset from the *Base Station RF Bandwidth edge*. The interfering signal offset is defined relative to the *Base Station RF Bandwidth edges* inside the *Inter RF Bandwidth gap*.

For the wanted signal at the assigned channel frequency and two interfering signals coupled to the *TAB connector*, using the parameters in tables 7.7.2.1-1 and 7.7.2.1-2, the following requirements shall be met:

- For any E-UTRA carrier, the throughput shall be $\geq 95\%$ of the *maximum throughput* of the reference measurement channel defined in 3GPP TS 36.104 [8], subclause 7.2.1.
- For any UTRA FDD carrier, the BER shall not exceed 0,001 for the reference measurement channel defined in 3GPP TS 25.104 [6], subclause 7.2.1.
- For any UTRA TDD carrier, the BER shall not exceed 0,001 for the reference measurement channel defined in 3GPP TS 25.105 [7], subclause 7.2.1.2.

Table 7.7.2.1-1: General intermodulation requirement

Base Station Type	Mean power of interfering signals (dBm)	Wanted Signal mean power (dBm)	Type of interfering signal
Wide Area BS	-48	$P_{\text{REFSENS}} + X$ dB (note 2)	See table 7.7.2.1-2
Medium Range BS	-44	$P_{\text{REFSENS}} + X$ dB (note 3)	
Local Area BS	-38	$P_{\text{REFSENS}} + X$ dB (note 4)	
NOTE 1: P_{REFSENS} depends on the RAT, the BS class and on the <i>channel bandwidth</i> , see subclause 7.2.2.			
NOTE 2: For Wide Area BS, "x" is equal to 6 dB in case of E-UTRA or UTRA wanted signals.			
NOTE 3: For Medium Range BS, "x" is equal to 9 dB in case of E-UTRA wanted signals, 6 dB in case of UTRA wanted signal.			
NOTE 4: For Local Area BS, "x" is equal to 12 dB in case of E-UTRA wanted signals, 6 dB in case of UTRA wanted signal.			

Table 7.7.2.1-2: Interfering signals for intermodulation requirement

RAT of the carrier adjacent to the upper/lower Base Station RF Bandwidth edge	Interfering signal centre frequency offset from the Base Station RF Bandwidth edge (MHz)	Type of interfering signal
E-UTRA 1.4 MHz	$\pm 2,0$ (BC1 and BC3) /	CW
	$\pm 2,1$ (BC2)	1,4 MHz E-UTRA signal
	$\pm 4,9$	
E-UTRA 3 MHz	$\pm 4,4$ (BC1 and BC3) /	CW
	$\pm 4,5$ (BC2)	3 MHz E-UTRA signal
	$\pm 10,5$	
UTRA FDD and E-UTRA 5 MHz	$\pm 7,5$	CW
	$\pm 17,5$	5 MHz E-UTRA signal
E-UTRA 10 MHz	$\pm 7,375$	CW
	$\pm 17,5$	5 MHz E-UTRA signal
E-UTRA 15 MHz	$\pm 7,25$	CW
	$\pm 17,5$	5 MHz E-UTRA signal
E-UTRA 20 MHz	$\pm 7,125$	CW
	$\pm 17,5$	5 MHz E-UTRA signal
GSM/EDGE	$\pm 7,575$	CW
	$\pm 17,5$	5 MHz E-UTRA signal
1,28 Mcps UTRA TDD	$\pm 2,3$ (BC3)	CW
	$\pm 5,6$ (BC3)	1,28 Mcps UTRA TDD signal

7.7.2.2 General narrowband intermodulation minimum requirement

Interfering signals shall be a CW signal and an E-UTRA 1RB signal as specified in 3GPP TS 37.104 [9], annex A.

The requirement is applicable outside the *Base Station RF Bandwidth* or *Radio Bandwidth*. The interfering signal offset is defined relative to the *Base Station RF Bandwidth edges* or *Radio Bandwidth edges*.

For *TAB connector* supporting operation in *non-contiguous spectrum* within each supported operating band, the requirement applies in addition inside any *sub-block gap* in case the *sub-block gap* is at least as wide as the *channel bandwidth* of the E-UTRA interfering signal in table 7.7.2.2-2. The interfering signal offset is defined relative to the *sub-block edges* inside the gap.

For *multi-band TAB connectors*, the requirement applies in addition inside any *Inter RF Bandwidth gap* at those connectors in case the gap size is at least as wide as the E-UTRA interfering signal in Table 7.7.2.2-2. The interfering signal offset is defined relative to the *Base Station RF Bandwidth edges* inside the *Inter RF Bandwidth gap*.

For the wanted signal at the assigned channel frequency and two interfering signals coupled to the *TAB connector*, using the parameters in tables 7.7.2.2-1 and 7.7.2.2-2, the following requirements shall be met:

- For any E-UTRA carrier, the throughput shall be ≥ 95 % of the *maximum throughput* of the reference measurement channel defined in 3GPP TS 36.104 [8], subclause 7.2.1.

- For any UTRA FDD carrier, the BER shall not exceed 0,001 for the reference measurement channel defined in 3GPP TS 25.104 [6], subclause 7.2.1.
- For any UTRA TDD carrier, the BER shall not exceed 0,001 for the reference measurement channel defined in 3GPP TS 25.105 [7], subclause 7.2.1.2.

Table 7.7.2.2-1: General narrowband intermodulation requirement

Base Station Type	Mean power of interfering signals (dBm)	Wanted Signal mean power (dBm)	Type of interfering signal
Wide Area BS	-52	$P_{\text{REFSENS}} + X$ dB (note)	See Table 7.7.2.2-2
Medium Range BS	-47		
Local Area BS	-44		
NOTE: P_{REFSENS} depends on the RAT, the BS class and on the <i>channel bandwidth</i> , see subclause 7.2.2. "x" is equal to 6 dB in case of E-UTRA or UTRA wanted signals.			

Table 7.7.2.2-2: Interfering signals for narrowband intermodulation requirement

RAT of the carrier adjacent to the upper/lower Base Station RF Bandwidth edge or edge of the sub-block	CW or 1RB interfering signal centre frequency offset from the <i>Base Station RF Bandwidth</i> edge or edge of <i>sub-block</i> inside a gap [kHz]	Type of interfering signal
E-UTRA 1.4 MHz	± 260 (BC1 and BC3) / ± 270 (BC2)	CW
	± 970 (BC1 and BC3) / ± 790 (BC2)	1,4 MHz E-UTRA signal, 1 RB (note 1)
E-UTRA 3 MHz	± 260 (BC1 and BC3) / ± 270 (BC2)	CW
	± 960 (BC1 and BC3) / ± 780 (BC2)	3,0 MHz E-UTRA signal, 1 RB (note 1)
E-UTRA 5 MHz	± 360	CW
	$\pm 1\ 060$	5 MHz E-UTRA signal, 1 RB (note 1)
E-UTRA 10 MHz (NOTE 2)	± 325	CW
	$\pm 1\ 240$	5 MHz E-UTRA signal, 1 RB (note 1)
E-UTRA 15 MHz (NOTE 2)	± 380	CW
	$\pm 1\ 600$	5MHz E-UTRA signal, 1 RB (note 1)
E-UTRA 20 MHz (NOTE 2)	± 345	CW
	$\pm 1\ 780$	5MHz E-UTRA signal, 1 RB (note 1)
UTRA FDD	± 345 (BC1 and BC2)	CW
	$\pm 1\ 780$ (BC1 and BC2)	5MHz E-UTRA signal, 1 RB (note 1)
GSM/EDGE	± 340	CW
	± 880	5MHz E-UTRA signal, 1 RB (note 1)
1,28 Mcps UTRA TDD	± 190 (BC3)	CW
	± 970 (BC3)	1,4 MHz E-UTRA signal, 1 RB (note 1)
NOTE 1: Interfering signal consisting of one resource block positioned at the stated offset, the <i>channel bandwidth</i> of the interfering signal is located adjacently to the <i>Base Station RF Bandwidth edge</i> .		
NOTE 2: This requirement shall apply only for an E-UTRA FRC A1-3 mapped to the frequency range at the channel edge adjacent to the interfering signals.		

7.7.3 Minimum requirement for single RAT UTRA operation

The single RAT UTRA FDD AAS BS of Wide Area BS class shall fulfil minimum requirements for receiver intermodulation specified in 3GPP TS 25.104 [6], subclause 7.6.1.

The single RAT UTRA FDD AAS BS of Medium Range BS class shall fulfil minimum requirements for receiver intermodulation specified in 3GPP TS 25.104 [6], subclause 7.6.1.

The single RAT UTRA FDD AAS BS of Local Area BS class shall fulfil minimum requirements for receiver intermodulation specified in 3GPP TS 25.104 [6], subclause 7.6.1.

The single RAT UTRA TDD AAS BS of Wide Area BS class shall fulfil minimum requirements for receiver intermodulation specified in 3GPP TS 25.105 [7], subclause 7.6.1.2.

The single RAT UTRA TDD AAS BS of Local Area BS class shall fulfil minimum requirements for receiver intermodulation specified in 3GPP TS 25.105 [7], subclause 7.6.1.2.

7.7.4 Minimum requirement for single RAT E- UTRA operation

The single RAT E-UTRA AAS BS of Wide Area BS class shall fulfil minimum requirements for receiver intermodulation specified in 3GPP TS 36.104 [8], subclause 7.8.

The single RAT E-UTRA AAS BS of Medium Range BS class shall fulfil minimum requirements for receiver intermodulation specified in 3GPP TS 36.104 [8], subclause 7.8.

The single RAT E-UTRA AAS BS of Local Area BS class shall fulfil minimum requirements for receiver intermodulation specified in 3GPP TS 36.104 [8], subclause 7.8.

7.8 In-channel selectivity

7.8.1 General

In-channel selectivity (ICS) is a measure of the receiver unit ability to receive a wanted signal at its assigned resource block locations in the presence of an interfering signal received at a larger power spectral density. In this condition a throughput requirement shall be met for a specified reference measurement channel. The requirement applies per *TAB connector*.

7.8.2 Minimum requirement for MSR operation

For E-UTRA, the minimum requirement for in-channel selectivity is specified in subclause 7.8.4.

This requirement is not applicable for UTRA operation.

7.8.3 Minimum requirement for single RAT UTRA operation

This requirement is not applicable for UTRA BS.

7.8.4 Minimum requirement for single RAT E-UTRA operation

The single RAT E-UTRA AAS BS of Wide Area BS class shall fulfil minimum requirements for in-channel selectivity specified in 3GPP TS 36.104 [8], subclause 7.4.1.

The single RAT E-UTRA AAS BS of Medium Range BS class shall fulfil minimum requirements for in-channel selectivity specified in 3GPP TS 36.104 [8], subclause 7.4.1.

The single RAT E-UTRA AAS BS of Local Area BS class shall fulfil minimum requirements for in-channel selectivity specified in 3GPP TS 36.104 [8], subclause 7.4.1.

The interfering signal shall be an E-UTRA signal as specified in 3GPP TS 36.104 [8], annex C and shall be time aligned with the wanted signal.

8 Performance requirements

8.1 General

8.1.1 UTRA operation

Performance requirements for the AAS BS are specified for the measurement channels defined in 3GPP TS 25.104 [2] and 3GPP TS 25.105 [3]. The requirements only apply to those measurement channels that are supported by the base station. For FRC8 in 3GPP TS 25.104 [2] the Non E-DPCCH boosting and E-DPCCH boosting requirement only apply for the option supported by the AAS BS. The performance requirements for the high speed train conditions which scenarios defined in 3GPP TS 25.104 [2] and 3GPP TS 25.105 [3] are optional.

Unless stated otherwise, performance requirements apply for a single cell only. Performance requirements for an AAS BS supporting UTRA FDD DC-HSUPA or DB-DC-HSUPA and UTRA TDD MC_HSUPA are defined in terms of single carrier requirements. For FDD operation the requirements in clause 8 shall be met with the transmitter unit(s) associated with the *TAB connectors(s)* in the operating band ON.

NOTE: In normal operating conditions the *TAB connectors(s)* in UTRA FDD operation are configured to transmit and receive at the same time. The transmitter unit(s) associated with the *TAB connectors* may be OFF for some of the tests as specified in 3GPP TS 37.145 [13].

In the referred UTRA specifications and in this section, the term BS with RX diversity refers to performance requirements for 2 *demodulation branches*, and BS without RX diversity refers to performance requirements for one *demodulation branch*.

For AAS BS with RX diversity, only the AAS BS performance requirements for BS with RX diversity apply, the required E_b/N_0 for UTRA FDD and \hat{I}_{or}/I_{oc} for UTRA TDD shall be applied separately for each *demodulation branch*.

For AAS BS without RX diversity, only the BS performance requirements without RX diversity apply. The required E_b/N_0 for UTRA FDD and \hat{I}_{or}/I_{oc} for UTRA TDD shall be applied for each AAS BS *demodulation branch*.

The E_b/N_0 used for UTRA FDD is defined as:

$$E_b / N_o = \frac{E_c}{N_o} \cdot \frac{L_{chip}}{L_{inf}}$$

Where:

E_c is the received total energy of DPDCH, DPCCH, S-DPCCH, HS-DPCCH, E-DPDCH, S-E-DPDCH, E-DPCCH and S-E-DPCCH per PN chip per *demodulation branch* from all branches.

N_o is the total one-sided noise power spectral density due to all noise sources

L_{chip} is the number of chips per frame

L_{inf} is the number of information bits in DTCH excluding CRC bits per frame

Table 8.1.1-1: Summary of AAS BS performance targets

Physical channel	Measurement channel	Static	Multi-path Case 1	Multi-path Case 2	Multi-path Case 3	Moving NOTE 1	Birth / Death NOTE 1	High Speed Train
		Performance metric						
DCH	12.2 kbps	BLER<10 ⁻²	BLER<10 ⁻²	BLER<10 ⁻²	BLER<10 ⁻²	BLER<10 ⁻²	BLER<10 ⁻²	BLER<10 ⁻²
	64 kbps	BLER<10 ⁻¹ ,10 ⁻²	BLER<10 ⁻¹ ,10 ⁻²	BLER<10 ⁻¹ ,10 ⁻²	BLER<10 ⁻¹ ,10 ⁻² ,10 ⁻³	BLER<10 ⁻¹ ,10 ⁻²	BLER<10 ⁻¹ ,10 ⁻²	BLER<10 ⁻¹ ,10 ⁻² NOTE 2
	144 kbps	BLER<10 ⁻¹ ,10 ⁻²	BLER<10 ⁻¹ ,10 ⁻²	BLER<10 ⁻¹ ,10 ⁻²	BLER<10 ⁻¹ ,10 ⁻² ,10 ⁻³	-	-	
	384 kbps	BLER<10 ⁻¹ ,10 ⁻²	BLER<10 ⁻¹ ,10 ⁻²	BLER<10 ⁻¹ ,10 ⁻²	BLER<10 ⁻¹ ,10 ⁻² ,10 ⁻³	-	-	

NOTE 1: UTRA FDD only.
NOTE 2: UTRA TDD only.
NOTE 3: If not stated otherwise, the above performance targets are applicable to UTRA TDD and to UTRA FDD.
NOTE 4: In case of multiple BLER level thresholds listed for single requirement and measurement channel combination, those BLER level values are reflected by set multiple requirements in 3GPP TS 25.104 [2], or 3GPP TS 25.105 [3].

8.1.2 E-UTRA operation

Performance requirements for the AAS BS are specified for the fixed reference channels (FRC) and propagation conditions defined in 3GPP TS 36.104 [4]. The requirements only apply to those FRCs that are supported by the AAS BS.

Unless stated otherwise, performance requirements apply for a single carrier only. Performance requirements for an AAS BS E-UTRA supporting *carrier aggregation* are defined in terms of single carrier requirements. For FDD operation the requirements shall be met with the transmitter unit(s) associated with the *TAB connectors(s)* in the operating band ON.

NOTE: In normal operating conditions *TAB connectors* in FDD operation are configured to transmit and receive at the same time. The transmitter unit(s) associated with the *TAB connectors* may be OFF for some of the tests as specified in 3GPP TS 37.145 [13].

In the referred E-UTRA specification, the term "RX antennas" refers to *demodulation branches* (and not physical antennas)

The SNR used in this clause is specified based on a single carrier and defined as:

$$\text{SNR} = S / N$$

Where:

S is the total signal energy in the subframe on a single *TAB connector*.

N is the noise energy in a bandwidth corresponding to the *transmission bandwidth* over the duration of a subframe.

8.2 Minimum requirements for MSR operation

For UTRA, minimum requirements for demodulation performance are specified in subclause 8.3.

For E-UTRA, minimum requirements for demodulation performance are specified in subclause 8.4.

8.3 Minimum requirements for UTRA operation

The single RAT UTRA FDD AAS BS shall fulfil all of the demodulation performance requirements specified in subclauses 8.2 to 8.7 of 3GPP TS 25.104 [6].

The single RAT UTRA TDD AAS BS shall fulfil all of the demodulation performance requirements specified in subclauses 8.2 to 8.5 of 3GPP TS 25.105 [7].

In the referred UTRA specifications, the term BS with RX diversity refers to performance requirements for 2 *demodulation branches*, and BS without RX diversity refers to performance requirements for one *demodulation branch*.

8.4 Minimum requirements for E-UTRA operation

The single RAT E-UTRA AAS BS shall fulfil all of the demodulation performance requirements specified in clause 8, subclauses 8.2 to 8.4 of 3GPP TS 36.104 [8].

In the referred E-UTRA specification, the term "RX antennas" refers to *demodulation branches* (and not physical antennas).

9 Radiated transmitter characteristics

9.1 General

Radiated transmitter characteristics requirements apply on the AAS BS including all its functional components active and for all foreseen modes of operation of the AAS BS unless otherwise stated.

9.2 Radiated transmit power

9.2.1 General

An AAS BS is declared to support one or more beams. Radiated transmit power is defined as the EIRP level for a declared beam at a specific *beam peak direction*.

For each beam, the requirement is based on declaration of a beam identity, *reference beam direction pair*, *beamwidth*, *rated beam EIRP*, *EIRP accuracy directions set*, the *beam direction pairs* at the maximum steering directions and their associated *rated beam EIRP* and *beamwidth(s)*.

For a declared beam and *beam direction pair*, the *rated beam EIRP* level is the maximum power that the base station is declared to radiate at the associated *beam peak direction* during the *transmitter ON period*.

For each *beam peak direction* associated with a *beam direction pair* within the *EIRP accuracy directions set*, a specific *rated beam EIRP* level may be claimed. Any claimed value shall be met within the accuracy requirement as described below. *Rated beam EIRP* is only required to be declared for the *beam direction pairs* subject to conformance testing as detailed in 3GPP TS 37.145 [13].

NOTE 1: *EIRP accuracy directions set* is set of *beam peak directions* for which the EIRP accuracy requirement is intended to be met. The *beam peak directions* are related to a corresponding contiguous range or discrete list of *beam centre directions* by the *beam direction pairs* included in the set.

NOTE 2: A *beam direction pair* is data set consisting of the *beam centre direction* and the related *beam peak direction*.

NOTE 3: A declared EIRP value is a value provided by the manufacturer for verification according to the conformance specification declaration requirements, whereas a claimed EIRP value is provided by the manufacturer to the equipment user for normal operation of the equipment and is not subject to formal conformance testing.

9.2.2 Minimum requirement for MSR operation

For each declared beam, in normal conditions, for any specific *beam peak direction* associated with a *beam direction pair* within the *EIRP accuracy directions set*, a manufacturer claimed EIRP level in the corresponding *beam peak direction* shall be achievable to within +2,2 dB and -2,2 dB of the claimed value.

9.2.3 Minimum requirement for single RAT UTRA operation

The minimum requirement for UTRA FDD and UTRA TDD 1,28Mcps option carrier radiated transmit power is in each case same as defined in subclause 9.2.2.

9.2.4 Minimum requirement for single RAT E-UTRA operation

The minimum requirement for E-UTRA carrier radiated transmit power is same as defined in subclause 9.2.2.

10 Radiated receiver characteristics

10.1 General

OTA receiver characteristics requirements apply to the *AAS BS* including all its functional components active unless otherwise stated in each requirement.

Unless otherwise stated the requirements in clause 10 apply during the *AAS BS receive period*.

The requirements in clause 10 shall be met for any transmitter setting.

The (E-UTRA) throughput requirements defined for the receiver characteristics in this clause do not assume HARQ retransmissions.

When the *AAS BS* is configured to receive multiple carriers, all the throughput requirements are applicable for each received carrier.

10.2 OTA sensitivity

10.2.1 General

The OTA sensitivity requirement is based upon the declaration of one or more *OTA sensitivity direction declarations* (OSDD), related to an *AAS BS receiver*.

The *AAS BS receiver* may optionally be capable of redirecting/changing the *receiver target* by means of adjusting BS settings resulting in multiple *sensitivity RoAoA*. The *sensitivity RoAoA* resulting from the current *AAS BS* settings is the active *sensitivity RoAoA*.

If the *AAS BS* is capable of redirecting the *receiver target* related to the OSDD then the OSDD shall include:

- The set(s) of RAT, *Channel bandwidth* and declared minimum EIS level applicable to all *sensitivity RoAoA* in the OSDD.
- A declared *receiver target redirection range*, describing all the angles of arrival that can be addressed for the OSDD through alternative settings in the *AAS BS*.
- Five declared *sensitivity RoAoA* comprising the conformance testing directions as detailed in 3GPP TS 37.145 part 2 [13].
- The *receiver target reference direction*.

NOTE 1: Some of the declared *sensitivity RoAoA* may coincide depending on the redirection capability.

NOTE 2: In addition to the declared *sensitivity RoAoA*, several *sensitivity RoAoA* may be implicitly defined by the *receiver target redirection range* without being explicitly declared in the OSDD.

NOTE 3: The declared OTA sensitivity applies only to the active *sensitivity RoAoA* inside the *receiver target redirection range*.

If the *AAS BS* is not capable of redirecting the *receiver target* related to the OSDD, then the OSDD includes only:

- The set(s) of RAT, *Channel bandwidth* and declared minimum EIS level applicable to the *sensitivity RoAoA* in the OSDD.
- One declared active *sensitivity RoAoA*.
- The *receiver target reference direction*.

NOTE 4: For AAS BS without target redirection capability, the declared (fixed) *sensitivity RoAoA* is always the active *sensitivity RoAoA*.

The OTA sensitivity EIS level declaration shall apply to all supported polarizations, under the assumption of *polarization matching*.

10.2.2 Minimum requirement for MSR operation

The minimum requirements for a UTRA FDD and for UTRA TDD 1,28 Mcps option carrier OTA sensitivity are defined in subclause 10.2.3.

The minimum requirement for an E-UTRA carrier OTA sensitivity is defined in subclause 10.2.4.

10.2.3 Minimum requirement for single RAT UTRA operation

For a received signal whose AoA of the incident wave is within the active *sensitivity RoAoA* of an OSDD, the error rate criterion as described below shall be met when the level of the arriving signal is equal to the minimum EIS level in the respective declared set of EIS level, RAT and *channel bandwidth*.

For UTRA FDD, the BER shall not exceed 0,001, using the 12,2 kbps data rate reference measurement channel specified in 3GPP TS 25.104 [2].

For UTRA TDD 1,28 Mcps option, the BER shall not exceed 0,001, using the 12,2 kbps data rate reference measurement channel specified in 3GPP TS 25.105 [3].

NOTE: The requirement applies for all declared sets of EIS, RAT and *channel bandwidth*, within the OSDD comprising UTRA, and for all related active *sensitivity RoAoA* settings within the AAS BS capability.

10.2.4 Minimum requirement for single RAT E-UTRA operation

For a received signal whose AoA of the incident wave is within the active *sensitivity RoAoA* of an OSDD the throughput criterion, as described below, shall be met when the level of the arriving signal is equal to the minimum EIS level in the respective declared set of EIS level, RAT and *channel bandwidth*.

The throughput shall be $\geq 95\%$ of the *maximum throughput* of the reference measurement channel as specified in 3GPP TS 36.104 [4] with parameters specified in table 10.2.4-1.

Table 10.2.4-1: E-UTRA AAS BS reference measurement channel

E-UTRA <i>channel bandwidth</i> (MHz)	Reference measurement channel
1.4	FRC A1-1 in 3GPP TS 36.104 [8], annex A.1
3	FRC A1-2 in 3GPP TS 36.104 [8], annex A.1
5	FRC A1-3 in 3GPP TS 36.104 [8], annex A.1
10	FRC A1-3 in 3GPP TS 36.104 [8], annex A.1 (NOTE)
15	FRC A1-3 in 3GPP TS 36.104 [8], annex A.1 (NOTE)
20	FRC A1-3 in 3GPP TS 36.104 [8], annex A.1 (NOTE)
NOTE:	The declared minimum EIS level is applied to a single instance of the reference measurement channel. This requirement shall be met for each consecutive application of a single instance of FRC A1-3 mapped to disjoint frequency ranges with a width of 25 resource blocks each.

NOTE 1: The requirement applies for all declared sets of EIS level, RAT and *channel bandwidth*, within the OSDD comprising E-UTRA, and for all related active *sensitivity RoAoA* settings within the AAS BS capability.

NOTE 2: Several OSDD EIS level declarations corresponding to different *channel bandwidths* may be made.

Annex A (normative): Environmental requirements for the BS equipment

The AAS BS equipment shall fulfil all the requirements in the full range of environmental conditions for the relevant environmental class. The environmental conditions and class shall be from the relevant IEC specifications or the corresponding ETSI specifications listed below.

IEC specifications for environmental requirements:

IEC 60721-3-3 [21]: "Stationary use at weather protected locations".

IEC 60721-3-4 [22]: "Stationary use at non weather protected locations".

ETSI specifications for environmental requirements:

ETSI EN 300 019-1-3 [23]: "Stationary use at weather protected locations".

ETSI EN 300 019-1-4 [24]: "Stationary use at non weather protected locations".

Normally it should be sufficient for all tests to be conducted using normal test conditions except where otherwise stated. For guidance on the use of test conditions to be used in order to show compliance refer to 3GPP TS 37.145 [13].

Annex B (informative): Change history

Change history							
Date	Meeting	TDoc	CR	Rev	Cat	Subject/Comment	New version
2015-10	RAN4#76 bis	R4-156540				Specification structure	0.0.1
2015-10	RAN4#77	R4-157517				Approved text proposals in the following documents were implemented: R4-156802 - TP - Text for TS, structure update R4-156926 - TP - Text for TS, General clauses R4-156804 - TP for TS Conducted transmitter requirements - subclause 6.5 R4-156805 - TP for TS Conducted transmitter requirements - clause 7 R4-156806 - Proposed OTA TX power TS text - clause 9 R4-156807 - TP - Text for TS, OTA sensitivity - clause 10	0.1.0
2016-02	RAN4#78	R4-161119				Approved text proposals in the following documents were implemented: R4-157316 - TP for TS37.105: correction on base station classes R4-157529 - TP - Text for TS, clean up missing references R4-157657 - TP for TS 37.105: Additions to OTA sensitivity in section 10 R4-158287 - TP for TS - clean up based on modification in section 4.9 R4-158288 - TP - Text for TS, definitions clean up. R4-158289 - TP - Text for TS, General section R4-158290 - TP - Text for TS, Section 5 R4-158291 - TP - Text for TS, Conducted Transmitter Requirements - section 6, 6.1, 6.2, 6.3, 6.4 R4-158292 - TP for 37.105: Unwanted Emissions R4-158293 - TP for TS 37.105: Radiated transmit power additions to section 9 R4-158294 - TP for TS 37.105: Adding transmitter IMD requirement text to section 6.7 R4-158295 - TP for TS 37.105: Adding receiver emission scaling to section 7.6	0.2.0
2016-02	RAN4#78	R4-161308				Approved text proposals in the following documents were implemented: R4-160932 - TP to TS 37.105 - EIRP accuracy value R4-160933 - TP to TS 37.105 - final clean up R4-160935 - TP-to TS 37.105 - add clarification of conformance requirements R4-160699 - TP for TS 37.105: Editorial corrections to radiated transmit power in clause 9 R4-161362 - TP for TS 37.105: AAS TS overall cleanup R4-161358 - TP for TS 37.105: Improvements to Radiated transmit power in section 3 and 9 R4-161364 - TP - to TS37.105 - Text amendment regarding multi-band exclusion bands for RX spurious emission R4-161363 - TP-to TS 37.105 - add annexes R4-161360 - TP for TS37.105 on UEM requirements R4-161236 - TP for 37.104: core specification design for AAS demodulation requirements R4-161495 - TP to 37.105 on Multi-band Tx/Rx TAB connector	0.3.0
2016-03	RAN#71	RP-160400				Presented to RAN for approval. Editorial cotrections recommended by ETSI editHelp	1.0.0
2016-03	RP-71					TR is approved by RAN plenary	13.0.0
06/2016	RP-72	RP-161142	2	1	F	Editorial corrections - alignment with 3GPP drafting rules	13.1.0
06/2016	RP-72	RP-161127	5	1	F	Clarifying UTRA TDD option in Performance section	13.1.0
06/2016	RP-72	RP-161142	6	-	F	Correction of interfering signal level for Tx intermodulation	13.1.0
06/2016	RP-72	RP-161142	7	1	F	Correct spectrum emission mask and operating band UEM absolute basic limits	13.1.0
06/2016	RP-72	RP-161142	11	1	D	37.105: Readability improvemenand corrections (sections 4 - 10)	13.1.0
09/2016	RP-73	RP-161635	15		D	TS 37.105: Readability improvements and corrections (section 3)	13.2.0
09/2016	RP-73	RP-161635	13	1	F	Correction of AAS Base Station performance targets	13.2.0
12/2016	RP-74	RP-162422	0018	1	F	MB MSR related corrections on receiver blocking	13.3.0
12/2016	RP-74	RP-162422	0020	2	D	CR to TS 37.105: Clarifications, definitions alignment and text improvements	13.3.0
12/2016	RP-74	RP-162422	0021	1	F	TS 37.105: Removal of operating band unwanted emissions for Band 46	13.3.0
12/2016	RP-74	RP-162422	0024	1	F	AAS ACLR absolute limit	13.3.0
12/2016	RP-74	RP-162422	0026	-	F	Clarification on the Rx diversity branches vs. demodulation branches terminology	13.3.0
03/2017	RP-75	RP-170586	0027	-	F	Corrections of the power range for SEM and OBUE requirement.	13.4.0

03/2017	RP-75	RP-170586	0028	1	F	TS 37.105: Alignment with legacy specifications on bands 45, 65, 66, 67, 68.	13.4.0
03/2017	RP-75	RP-170586	0029	1	F	TS 37.105: Corrections on references	13.4.0
03/2017	RP-75	RP-170586	0030	-	B	CR to TS 37.105: Isolation of the NB-IoT feature from the AAS BS specification	13.4.0
03/2017	RP-75	RP-170586	0031	1	B	CR to TS 37.105: Isolation of Band 46 from the AAS BS specification	13.4.0
03/2017	RP-75	RP-170586	0032	1	D	CR to TS 37.105: editorial corrections	13.4.0
03/2017	RP-75	RP-170586	0033	-	F	CR to TS 37.105: Rel-13 single RAT and MSR specification reference updates: MB MSR correction	13.4.0
03/2017	RP-75	-	-	-	-	Update to Rel-14 version (MCC)	14.0.0

History

Document history		
V14.0.0	April 2017	Publication