

# ETSI TS 137 141 V9.1.0 (2010-10)

---

*Technical Specification*

**Digital cellular telecommunications system (Phase 2+);  
Universal Mobile Telecommunications System (UMTS);  
LTE;  
E-UTRA, UTRA and GSM/EDGE;  
Multi-Standard Radio (MSR) Base Station (BS)  
conformance testing  
(3GPP TS 37.141 version 9.1.0 Release 9)**

---



---

Reference

RTS/TSGR-0437141v910

---

Keywords

GSM, LTE, UMTS

**ETSI**

650 Route des Lucioles  
F-06921 Sophia Antipolis Cedex - FRANCE

Tel.: +33 4 92 94 42 00 Fax: +33 4 93 65 47 16

Siret N° 348 623 562 00017 - NAF 742 C  
Association à but non lucratif enregistrée à la  
Sous-Préfecture de Grasse (06) N° 7803/88

---

**Important notice**

Individual copies of the present document can be downloaded from:

<http://www.etsi.org>

The present document may be made available in more than one electronic version or in print. In any case of existing or perceived difference in contents between such versions, the reference version is the Portable Document Format (PDF). In case of dispute, the reference shall be the printing on ETSI printers of the PDF version kept on a specific network drive within ETSI Secretariat.

Users of the present document should be aware that the document may be subject to revision or change of status. Information on the current status of this and other ETSI documents is available at

<http://portal.etsi.org/tb/status/status.asp>

If you find errors in the present document, please send your comment to one of the following services:

[http://portal.etsi.org/chaicor/ETSI\\_support.asp](http://portal.etsi.org/chaicor/ETSI_support.asp)

---

**Copyright Notification**

No part may be reproduced except as authorized by written permission.  
The copyright and the foregoing restriction extend to reproduction in all media.

© European Telecommunications Standards Institute 2010.  
All rights reserved.

**DECT**<sup>TM</sup>, **PLUGTESTS**<sup>TM</sup>, **UMTS**<sup>TM</sup>, **TIPHON**<sup>TM</sup>, the TIPHON logo and the ETSI logo are Trade Marks of ETSI registered for the benefit of its Members.

**3GPP**<sup>TM</sup> is a Trade Mark of ETSI registered for the benefit of its Members and of the 3GPP Organizational Partners.

**LTE**<sup>TM</sup> is a Trade Mark of ETSI currently being registered

for the benefit of its Members and of the 3GPP Organizational Partners.

**GSM**<sup>®</sup> and the GSM logo are Trade Marks registered and owned by the GSM Association.

---

## Intellectual Property Rights

IPRs essential or potentially essential to the present document may have been declared to ETSI. The information pertaining to these essential IPRs, if any, is publicly available for **ETSI members and non-members**, and can be found in ETSI SR 000 314: "*Intellectual Property Rights (IPRs); Essential, or potentially Essential, IPRs notified to ETSI in respect of ETSI standards*", which is available from the ETSI Secretariat. Latest updates are available on the ETSI Web server (<http://webapp.etsi.org/IPR/home.asp>).

Pursuant to the ETSI IPR Policy, no investigation, including IPR searches, has been carried out by ETSI. No guarantee can be given as to the existence of other IPRs not referenced in ETSI SR 000 314 (or the updates on the ETSI Web server) which are, or may be, or may become, essential to the present document.

---

## Foreword

This Technical Specification (TS) has been produced by ETSI 3rd Generation Partnership Project (3GPP).

The present document may refer to technical specifications or reports using their 3GPP identities, UMTS identities or GSM identities. These should be interpreted as being references to the corresponding ETSI deliverables.

The cross reference between GSM, UMTS, 3GPP and ETSI identities can be found under <http://webapp.etsi.org/key/queryform.asp>.

# Contents

Intellectual Property Rights .....	2
Foreword.....	2
Foreword.....	9
1 Scope .....	10
2 References .....	10
3 Definitions, symbols and abbreviations .....	11
3.1 Definitions .....	11
3.2 Symbols.....	12
3.3 Abbreviations .....	13
4 General test conditions and declarations .....	14
4.1 Measurement uncertainties and test requirements .....	14
4.1.1 General.....	14
4.1.2 Acceptable uncertainty of Test System.....	15
4.1.2.1 Measurement of transmitter .....	16
4.1.2.2 Measurement of receiver.....	16
4.1.3 Interpretation of measurement results.....	16
4.2 Base Station classes.....	17
4.3 Regional requirements.....	17
4.4 Operating bands and band categories .....	18
4.4.1 Band category 1 aspects (BC1).....	19
4.4.2 Band category 2 aspects (BC2).....	20
4.4.3 Band category 3 aspects (BC3).....	20
4.5 Channel arrangement.....	20
4.5.1 Channel spacing.....	20
4.5.2 Channel raster .....	20
4.5.3 Carrier frequencies and numbering.....	20
4.6 Manufacturer's declarations of regional and optional requirements .....	21
4.6.1 Operating band and frequency range .....	21
4.6.2 Spurious emissions category.....	21
4.6.3 Additional operating band unwanted emissions .....	21
4.6.4 Co-existence with other systems.....	21
4.6.5 Co-location with other Base Stations.....	22
4.7 Capability set definition and manufacturer's declarations of supported RF configurations .....	22
4.7.1 Definition of Capability Sets (CS).....	22
4.7.2 Manufacturer's declarations of supported RF configurations .....	23
4.8 MSR test configurations .....	24
4.8.1 TC1: UTRA multicarrier operation .....	24
4.8.1.1 TC1a generation.....	24
4.8.1.2 TC1b generation.....	24
4.8.1.3 TC1 power allocation.....	24
4.8.2 TC2: E-UTRA multicarrier operation.....	24
4.8.2.1 TC2 generation.....	24
4.8.2.2 TC2 power allocation.....	25
4.8.3 TC3: UTRA and E-UTRA multi RAT operation.....	25
4.8.3.1 TC3a generation .....	25
4.8.3.2 TC3b generation.....	25
4.8.3.3 TC3 power allocation.....	25
4.8.4 TC4: BC2 transmitter operation.....	25
4.8.4.1 TC4a generation.....	26
4.8.4.2 TC4b generation.....	26
4.8.4.3 TC4c generation.....	26
4.8.4.4 TC4d generation.....	27
4.8.4.5 TC4e generation.....	27

4.8.4.6	TC4 power allocation .....	27
4.8.5	TC5: BC2 receiver operation .....	27
4.8.5.1	TC5a generation .....	27
4.8.5.2	TC5b generation .....	28
4.8.6	TC6: Single carrier for receiver tests .....	28
4.8.6.1	TC6a generation .....	28
4.8.6.2	TC6b generation .....	28
4.8.6.3	TC6c generation .....	28
4.9	RF channels and test models .....	28
4.9.1	RF channels .....	28
4.9.2	Test models .....	29
4.10	BS configurations .....	29
4.10.1	Transmit configurations .....	29
4.10.1.1	Multi-carrier transmission with multiple transmitter antenna connectors, transmit diversity and MIMO transmission .....	30
4.10.2	Receive configurations .....	30
4.10.2.1	Multi-carrier reception with multiple receiver antenna connectors, receiver diversity .....	30
4.10.3	Duplexers .....	31
4.10.4	Power supply options .....	31
4.10.5	Ancillary RF amplifiers .....	31
4.10.6	BS with integrated Iuant BS modem .....	32
4.10.7	BS using antenna arrays .....	32
4.10.7.1	Receiver tests .....	32
4.10.7.2	Transmitter tests .....	32
4.11	Format and interpretation of tests .....	33
5	Applicability of requirements and test configurations .....	34
5.1	Multi-RAT capable Base Stations .....	35
5.2	Single-RAT Multi-carrier capable Base Stations .....	40
6	Transmitter characteristics .....	44
6.1	General .....	44
6.2	Base Station output power .....	44
6.2.1	Base Station maximum output power .....	44
6.2.1.1	Definition and applicability .....	44
6.2.1.2	Minimum requirement .....	45
6.2.1.3	Test purpose .....	45
6.2.1.4	Method of test .....	45
6.2.1.4.1	Initial conditions .....	45
6.2.1.4.2	Procedure .....	45
6.2.1.5	Test requirements .....	45
6.2.2	E-UTRA DL RS power .....	45
6.2.2.1	Definition and applicability .....	45
6.2.2.2	Minimum requirement .....	45
6.2.2.3	Test purpose .....	45
6.2.2.4	Method of test .....	46
6.2.2.5	Test requirements .....	46
6.2.3	UTRA FDD primary CPICH power .....	46
6.2.3.1	Definition and applicability .....	46
6.2.3.2	Minimum requirement .....	46
6.2.3.3	Test purpose .....	46
6.2.3.4	Method of test .....	46
6.2.3.5	Test requirements .....	46
6.2.4	UTRA TDD primary CCPCH .....	46
6.2.4.1	Definition and applicability .....	46
6.2.4.2	Minimum requirement .....	46
6.2.4.3	Test purpose .....	46
6.2.4.4	Method of test .....	46
6.2.4.5	Test requirements .....	47
6.3	Output power dynamics .....	47
6.3.1	Definition and applicability .....	47
6.3.2	Minimum Requirement .....	47

6.3.3	Test purpose.....	47
6.3.4	Method of test.....	47
6.3.5	Test Requirement.....	47
6.4	Transmit ON/OFF power.....	47
6.4.1	Definition and applicability.....	47
6.4.2	Minimum Requirement.....	48
6.4.3	Test purpose.....	48
6.4.4	Method of test.....	48
6.4.4.1	Initial conditions.....	48
6.4.4.2	Procedure.....	48
6.4.5	Test requirement.....	48
6.5	Transmitted signal quality.....	49
6.5.1	Modulation quality.....	49
6.5.1.1	Definition and applicability.....	49
6.5.1.2	Minimum Requirement.....	49
6.5.1.3	Test purpose.....	49
6.5.1.4	Method of test.....	49
6.5.1.4.1	Initial conditions.....	49
6.5.1.4.2	Procedure.....	49
6.5.1.5	Test Requirements.....	50
6.5.1.5.1	E-UTRA test requirement.....	50
6.5.1.5.2	UTRA FDD test requirement.....	50
6.5.1.5.3	UTRA TDD test requirement.....	50
6.5.1.5.4	GSM/EDGE test requirement.....	50
6.5.2	Frequency error.....	50
6.5.2.1	Definition and applicability.....	50
6.5.2.2	Minimum Requirement.....	50
6.5.2.3	Test purpose.....	50
6.5.2.4	Method of test.....	50
6.5.2.5	Test Requirements.....	50
6.5.2.5.1	E-UTRA test requirement.....	50
6.5.2.5.2	UTRA FDD test requirement.....	50
6.5.2.5.3	UTRA TDD test requirement.....	50
6.5.2.5.4	GSM/EDGE test requirement.....	51
6.5.3	Time alignment between transmitter branches.....	51
6.5.3.1	Definition and applicability.....	51
6.5.3.2	Minimum requirement.....	51
6.5.3.3	Test purpose.....	51
6.5.3.4	Method of test.....	51
6.5.3.5	Test requirement.....	51
6.6	Unwanted emissions.....	51
6.6.1	Transmitter spurious emissions.....	52
6.6.1.1	Definition and applicability.....	52
6.6.1.2	Minimum requirement.....	52
6.6.1.3	Test purpose.....	52
6.6.1.4	Method of test.....	52
6.6.1.4.1	Initial conditions.....	52
6.6.1.4.2	Procedure.....	52
6.6.1.5	Test requirements.....	52
6.6.1.5.1	Spurious emissions (Category A).....	53
6.6.1.5.2	Spurious emissions (Category B).....	53
6.6.1.5.3	Additional test requirement for BC2 (category B).....	53
6.6.1.5.4	Protection of the BS receiver of own or different BS.....	53
6.6.1.5.5	Additional spurious emission requirements.....	54
6.6.1.5.6	Co-location with other Base Stations.....	57
6.6.2	Operating band unwanted emissions.....	59
6.6.2.1	Definition and applicability.....	59
6.6.2.2	Minimum requirement.....	59
6.6.2.3	Test purpose.....	59
6.6.2.4	Method of test.....	60
6.6.2.4.1	Initial conditions.....	60
6.6.2.4.2	Procedure.....	60

6.6.2.5	Test requirement .....	60
6.6.2.5.1	Test requirements for Band Categories 1 and 3.....	60
6.6.2.5.2	Test requirements for Band Category 2.....	61
6.6.2.5.3	Test requirements for GSM/EDGE single-RAT requirements.....	62
6.6.2.5.4	Test requirements for additional requirements .....	62
6.6.2.5.4.1	Limits in FCC Title 47.....	62
6.6.2.5.4.2	Unsynchronized operation for BC3 .....	62
6.6.2.5.4.3	Protection of DTT.....	63
6.6.2.5.4.4	Co-existence with services in adjacent frequency bands .....	63
6.6.3	Occupied bandwidth .....	63
6.6.3.1	Definition and applicability.....	63
6.6.3.2	Minimum requirements.....	63
6.6.3.3	Test purpose .....	63
6.6.3.4	Method of test .....	64
6.6.3.5	Test requirement .....	64
6.6.4	Adjacent Channel Leakage power Ratio (ACLR) .....	64
6.6.4.1	Definition and applicability.....	64
6.6.4.2	Minimum requirement .....	64
6.6.4.3	Test purpose .....	64
6.6.4.4	Method of test .....	64
6.6.4.5	Test requirements.....	64
6.6.4.5.1	E-UTRA test requirement.....	64
6.6.4.5.2	UTRA FDD test requirement .....	64
6.6.4.5.3	UTRA TDD test requirement .....	65
6.7	Transmitter intermodulation.....	65
6.7.1	Definition and applicability .....	65
6.7.2	Minimum requirement .....	65
6.7.3	Test purpose.....	65
6.7.4	Method of test .....	65
6.7.4.1	Initial conditions .....	65
6.7.4.2	Procedure .....	65
6.7.4.2.1	General minimum requirement test procedure .....	65
6.7.4.2.2	Additional minimum requirement (BC2) test procedure.....	66
6.7.4.2.3	Additional minimum requirement (BC3) test procedure.....	66
6.7.5	Test requirements.....	67
6.7.5.1	General test requirement .....	67
6.7.5.2	Additional test requirement (BC2).....	67
6.7.5.3	Additional test requirement (BC3).....	67
7	Receiver characteristics.....	67
7.1	General .....	67
7.2	Reference sensitivity level.....	68
7.2.1	Definition and applicability .....	68
7.2.2	Minimum requirement .....	68
7.2.3	Test purpose.....	68
7.2.4	Method of test.....	68
7.2.5	Test requirements.....	68
7.3	Dynamic range .....	68
7.3.1	Definition and applicability .....	68
7.3.2	Minimum requirement .....	68
7.3.3	Test purpose.....	68
7.3.4	Method of test.....	69
7.3.5	Test requirements.....	69
7.4	In-band selectivity and blocking .....	69
7.4.1	Definition and applicability .....	69
7.4.2	Minimum requirement .....	69
7.4.3	Test purpose.....	69
7.4.4	Method of test.....	69
7.4.4.1	Initial conditions .....	69
7.4.4.2	Procedure for general blocking .....	70
7.4.4.3	Procedure for narrowband blocking.....	70
7.4.4.4	Procedure for additional narrowband blocking for GSM/EDGE .....	70

7.4.4.5	Procedure for GSM/EDGE AM suppression .....	70
7.4.4.6	Procedure for additional BC3 blocking requirement.....	70
7.4.5	Test requirements.....	70
7.4.5.1	General blocking test requirement .....	70
7.4.5.2	General narrowband blocking test requirement .....	71
7.4.5.3	Additional narrowband blocking test requirement for GSM/EDGE .....	71
7.4.5.4	GSM/EDGE test requirements for AM suppression .....	72
7.4.5.5	Additional BC3 blocking test requirement.....	72
7.5	Out-of-band blocking .....	72
7.5.1	Definition and applicability .....	72
7.5.2	Minimum requirement .....	72
7.5.3	Test purpose.....	72
7.5.4	Method of test .....	72
7.5.4.1	Initial conditions .....	72
7.5.4.2	Procedure .....	73
7.5.5	Test requirements.....	73
7.5.5.1	General out-of-band blocking test requirements .....	73
7.5.5.2	Co-location test requirements.....	74
7.6	Receiver spurious emissions.....	76
7.6.1	Definition and applicability .....	76
7.6.2	Minimum requirements.....	76
7.6.3	Test purpose.....	76
7.6.4	Method of test .....	76
7.6.4.1	Initial conditions .....	76
7.6.4.2	Procedure .....	76
7.6.5	Test requirements.....	76
7.6.5.1	General test requirements.....	76
7.6.5.2	Additional test requirement for BC2 (Category B) .....	77
7.7	Receiver intermodulation .....	77
7.7.1	Definition and applicability .....	77
7.7.2	Minimum requirement .....	77
7.7.3	Test purpose.....	77
7.7.4	Method of test .....	77
7.7.4.1	Initial conditions .....	77
7.7.4.2	Procedure for general and narrowband intermodulation .....	78
7.7.4.3	Procedure for additional narrowband intermodulation for GSM/EDGE.....	78
7.7.5	Test requirements.....	78
7.7.5.1	General intermodulation test requirement .....	78
7.7.5.2	General narrowband intermodulation test requirement .....	79
7.7.5.3	Additional narrowband intermodulation test requirement for GSM/EDGE.....	80
7.8	In-channel selectivity .....	80
7.8.1	Definition and applicability .....	80
7.8.2	Minimum requirement .....	80
7.8.3	Test purpose.....	80
7.8.4	Method of testing.....	81
7.8.5	Test requirements.....	81
8	Performance requirements.....	81
<b>Annex A (normative): Characteristics of interfering signals .....</b>		<b>82</b>
A.1	UTRA FDD interfering signal.....	82
A.2	UTRA TDD interfering signal .....	82
A.3	E-UTRA interfering signal.....	82
<b>Annex B (normative): Environmental requirements for the BS equipment .....</b>		<b>83</b>
B.1	General .....	83
B.2	Normal test environment.....	83
B.3	Extreme test environment.....	83
B.3.1	Extreme temperature .....	83



B.4	Vibration.....	84
B.5	Power supply .....	84
B.6	Measurement of test environments.....	84
<b>Annex C (informative): Test Tolerances and Derivation of test requirements.....</b>		<b>85</b>
C.1	Measurement of transmitter.....	86
C.2	Measurement of receiver .....	88
<b>Annex D (informative): Measurement system set-up .....</b>		<b>89</b>
D.1	Transmitter .....	89
D.1.1	Base station output power, transmitter ON/OFF power, modulation quality, transmitter spurious emissions and operating band unwanted emissions.....	89
D.1.2	Transmitter intermodulation .....	89
D.2	Receiver.....	90
D.2.1	Blocking characteristics .....	90
D.2.2	Receiver spurious emissions.....	90
D.2.3	Receiver intermodulation .....	90
<b>Annex E (informative): Change history .....</b>		<b>91</b>
History .....		93

---

# Foreword

This Technical Specification has been produced by the 3<sup>rd</sup> Generation Partnership Project (3GPP).

The contents of the present document are subject to continuing work within the TSG and may change following formal TSG approval. Should the TSG modify the contents of the present document, it will be re-released by the TSG with an identifying change of release date and an increase in version number as follows:

Version x.y.z

where:

- x the first digit:
  - 1 presented to TSG for information;
  - 2 presented to TSG for approval;
  - 3 or greater indicates TSG approved document under change control.
- y the second digit is incremented for all changes of substance, i.e. technical enhancements, corrections, updates, etc.
- z the third digit is incremented when editorial only changes have been incorporated in the document.

---

# 1 Scope

The present document specifies the Radio Frequency (RF) test methods and conformance requirements for E-UTRA, UTRA and GSM/EDGE Multi-Standard Radio (MSR) Base Station (BS). These have been derived from, and are consistent with the E-UTRA, UTRA and GSM/EDGE MSR BS specification defined in [2].

---

# 2 References

The following documents contain provisions which, through reference in this text, constitute provisions of the present document.

- References are either specific (identified by date of publication, edition number, version number, etc.) or non-specific.
- For a specific reference, subsequent revisions do not apply.
- For a non-specific reference, the latest version applies. In the case of a reference to a 3GPP document (including a GSM document), a non-specific reference implicitly refers to the latest version of that document *in the same Release as the present document*.

- [1] 3GPP TR 21.905: "Vocabulary for 3GPP Specifications".
- [2] 3GPP TS 37.104: "E-UTRA, UTRA and GSM/EDGE; Multi-Standard Radio (MSR) Base Station (BS) radio transmission and reception".
- [3] 3GPP TS 25.104: "Base Station (BS) radio transmission and reception (FDD) ".
- [4] 3GPP TS 25.105: "Base Station (BS) radio transmission and reception (TDD) ".
- [5] 3GPP TS 36.104: "Evolved Universal Terrestrial Radio Access (E-UTRA); Base Station (BS) radio transmission and reception".
- [6] 3GPP TS 45.005: "Radio transmission and reception".
- [7] ITU-R Recommendation M.1545, "Measurement uncertainty as it applies to test limits for the terrestrial component of International Mobile Telecommunications-2000".
- [8] "Title 47 of the Code of Federal Regulations (CFR)", Federal Communications Commission.
- [9] 3GPP TS 36.141: "Evolved Universal Terrestrial Radio Access (E-UTRA); Base Station (BS) conformance testing".
- [10] 3GPP TS 25.141: "Base Station (BS) conformance testing (FDD) ".
- [11] 3GPP TS 51.021: "Base Station System (BSS) equipment specification; Radio aspects".
- [12] 3GPP TS 25.142: "Base Station (BS) conformance testing (TDD) ".
- [13] Recommendation ITU-R SM.329-10, "Unwanted emissions in the spurious domain".
- [14] 3GPP TR 25.942: "Radio Frequency (RF) system scenarios".
- [15] ITU-R recommendation SM.328: "Spectra and bandwidth of emissions".
- [16] IEC 60721: "Classification of environmental conditions".
- [17] IEC 60721-3-3: "Classification of environmental conditions - Part 3-3: Classification of groups of environmental parameters and their severities - Stationary use at weather protected locations".
- [18] IEC 60721-3-4: "Classification of environmental conditions - Part 3: Classification of groups of environmental parameters and their severities - Section 4: Stationary use at non-weather protected locations".

- [19] ETSI EN 300 019-1-3, *European Standard (Telecommunications series)*, 'Environmental Engineering (EE); Environmental conditions and environmental tests for telecommunications equipment; Part 1-3: Classification of environmental conditions; Stationary use at weather protected locations'
- [20] ETSI EN 300 019-1-4, *European Standard (Telecommunications series)*, 'Environmental Engineering (EE); Environmental conditions and environmental tests for telecommunications equipment; Part 1-4: Classification of environmental conditions; Stationary use at non-weather protected locations'.
- [21] IEC 60068-2-1 (2007): "Environmental testing - Part 2: Tests. Tests A: Cold".
- [22] IEC 60068-2-2 (2007): "Environmental testing - Part 2: Tests. Tests B: Dry heat".
- [23] IEC 60068-2-6 (2007): "Environmental testing - Part 2: Tests - Test Fc: Vibration (sinusoidal)".

---

## 3 Definitions, symbols and abbreviations

### 3.1 Definitions

For the purposes of the present document, the terms and definitions given in TR 21.905 [1] and the following apply. A term defined in the present document takes precedence over the definition of the same x term, if any, in TR 21.905 [1].

**Band category:** A group of operating bands for which the same MSR scenarios apply

**Base Station RF bandwidth:** The bandwidth in which a Base Station transmits and receives multiple carriers and/or RATs simultaneously

**Base Station RF bandwidth edge:** The frequency of one of the edges of the Base Station RF bandwidth

**Carrier:** The modulated waveform conveying the E-UTRA, UTRA or GSM/EDGE physical channels

**Channel bandwidth:** The bandwidth supporting a single E-UTRA RF carrier with the transmission bandwidth configured in the uplink or downlink of a cell. The channel bandwidth is measured in MHz and is used as a reference for transmitter and receiver RF requirements.

**Carrier power:** The power at the antenna connector in the channel bandwidth of the carrier averaged over at least one subframe for E-UTRA, at least one slot for UTRA and the useful part of the burst for GSM/EDGE.

**Downlink operating band:** The part of the operating band designated for downlink.

**Lower RF bandwidth edge:** The frequency of the lower edge of the Base Station RF bandwidth, used as a frequency reference point for transmitter and receiver requirements

**Maximum Base Station RF bandwidth:** The maximum RF bandwidth supported by a BS within an operating band.

**Maximum carrier output power:** Carrier power available at the antenna connector for a specified reference condition.

**Maximum RAT power:** The sum of the power of all carriers of the same RAT available at the antenna connector for a specified reference condition.

**Maximum throughput:** The maximum achievable throughput for a reference measurement channel.

**Maximum total output power:** The sum of the power of all carriers available at the antenna connector for a specified reference condition.

**Measurement bandwidth:** The bandwidth in which an emission level is specified.

**MSR Base Station:** Base Station characterized by the ability of its receiver and transmitter to process two or more carriers in common active RF components simultaneously in a declared RF bandwidth, where at least one carrier is of a different RAT than the other carrier(s).

**Multi-carrier transmission configuration:** A set of one or more contiguous carriers that a BS is able to transmit simultaneously according to the manufacturer's specification.

**Occupied bandwidth:** The width of a frequency band such that, below the lower and above the upper frequency limits, the mean powers emitted are each equal to a specified percentage  $\beta/2$  of the total mean power of a given emission.

**Operating band:** A frequency range in which E-UTRA, UTRA or GSM/EDGE operates (paired or unpaired), that is defined with a specific set of technical requirements.

NOTE: The operating band(s) for a BS is declared by the manufacturer.

**RAT power:** The sum of all carrier powers for all carriers of the same type.

**Rated carrier output power:** The mean power level per carrier that the manufacturer has declared to be available at the antenna connector.

**Rated RAT output power:** The mean power level per RAT that the manufacturer has declared to be available at the antenna connector.

**Rated total output power:** The total mean power level that the manufacturer has declared to be available at the antenna connector.

**RRC filtered mean power:** The mean power of a UTRA carrier as measured through a root raised cosine filter with roll-off factor  $\alpha$  and a bandwidth equal to the chip rate of the radio access mode.

NOTE: The RRC filtered mean power of a perfectly modulated UTRA signal is 0.246 dB lower than the mean power of the same signal.

**Throughput:** The number of payload bits successfully received per second for a reference measurement channel in a specified reference condition.

**Total output power:** The sum of all carrier powers for all carriers transmitted by the BS.

**Transmission bandwidth:** Bandwidth of an instantaneous E-UTRA transmission from a UE or BS, measured in Resource Block units.

**Transmission bandwidth configuration:** The highest E-UTRA transmission bandwidth allowed for uplink or downlink in a given channel bandwidth, measured in Resource Block units.

**Uplink operating band:** The part of the operating band designated for uplink.

**Upper RF bandwidth edge:** The frequency of the upper edge of the Base Station RF bandwidth, used as a frequency reference point for transmitter and receiver requirements.

## 3.2 Symbols

For the purposes of the present document, the following symbols apply:

$\alpha$	Roll-off factor
$\beta$	Percentage of the mean transmitted power emitted outside the occupied bandwidth on the assigned channel
$BW_{\text{Channel}}$	Channel bandwidth (for E-UTRA)
$BW_{\text{Config}}$	Transmission bandwidth configuration (for E-UTRA), expressed in MHz, where $BW_{\text{Config}} = N_{\text{RB}} \times 180$ kHz in the uplink and $BW_{\text{Config}} = 15$ kHz + $N_{\text{RB}} \times 180$ kHz in the downlink.
$BW_{\text{RF}}$	Base Station RF bandwidth, where $BW_{\text{RF}} = F_{\text{BW RF,high}} - F_{\text{BW RF,low}}$
$BW_{\text{RF,max}}$	Maximum Base Station RF bandwidth
$f$	Frequency
$\Delta f$	Separation between the Base Station RF bandwidth edge frequency and the nominal -3dB point of the measuring filter closest to the carrier frequency
$\Delta f_{\text{max}}$	The largest value of $\Delta f$ used for defining the requirement
$F_{\text{C}}$	Carrier centre frequency
$f_{\text{offset}}$	Separation between the Base Station RF bandwidth edge frequency and the centre of the measuring filter
$f_{\text{offset,max}}$	The maximum value of $f_{\text{offset}}$ used for defining the requirement

$F_{BW\text{ RF,high}}$	Upper RF bandwidth edge, where $F_{BW\text{ RF,high}} = F_{C,\text{high}} + F_{\text{offset, RAT}}$
$F_{BW\text{ RF,low}}$	Lower RF bandwidth edge, where $F_{BW\text{ RF,low}} = F_{C,\text{low}} - F_{\text{offset, RAT}}$
$F_{C,\text{high}}$	Center frequency of the highest transmitted/received carrier.
$F_{C,\text{low}}$	Center frequency of the lowest transmitted/received carrier.
$F_{\text{offset, RAT}}$	Frequency offset from $F_{C,\text{high}}$ to the <i>upper RF bandwidth edge</i> or $F_{C,\text{low}}$ to the <i>lower RF bandwidth edge</i> for a specific RAT.
$F_{DL,\text{low}}$	The lowest frequency of the downlink operating band
$F_{DL,\text{high}}$	The highest frequency of the downlink operating band
$F_{UL,\text{low}}$	The lowest frequency of the uplink operating band
$F_{UL,\text{high}}$	The highest frequency of the uplink operating band
$N_{RB}$	Transmission bandwidth configuration, expressed in units of resource blocks (for E-UTRA)
$P_{\text{REFSENS}}$	Reference Sensitivity power level

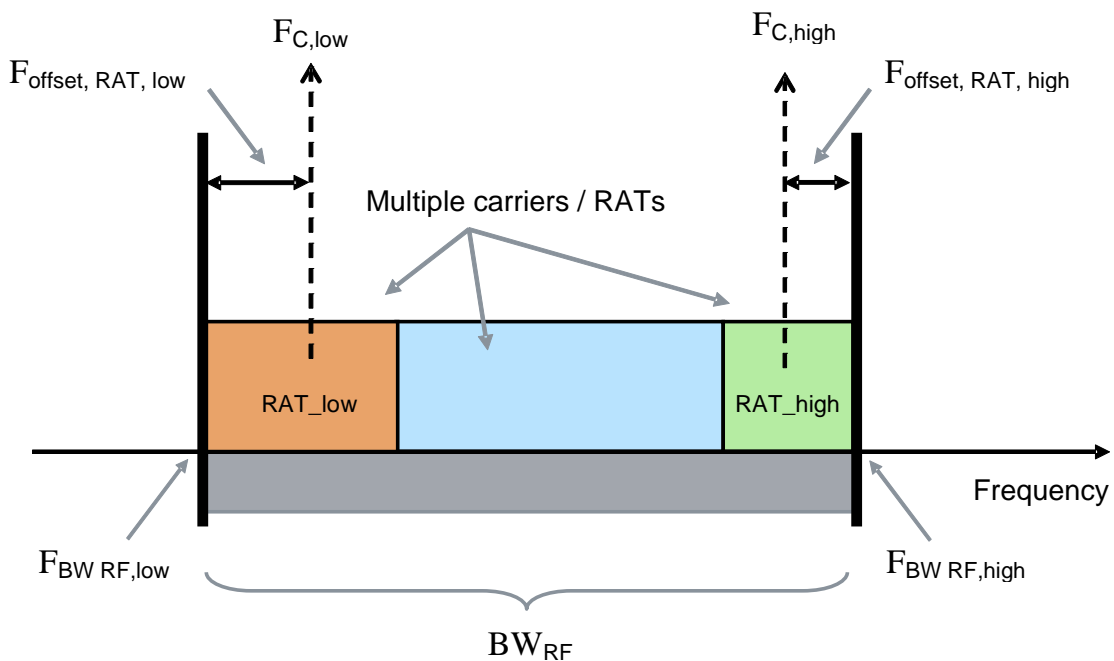

Figure 3.2-1: Illustration of RF bandwidth related symbols and definitions for Multi-standard Radio.

### 3.3 Abbreviations

For the purposes of the present document, the abbreviations given in TR 21.905 [1] and the following apply. An abbreviation defined in the present document takes precedence over the definition of the same abbreviation, if any, in TR 21.905 [1].

ACIR	Adjacent Channel Interference Ratio
ACLR	Adjacent Channel Leakage Ratio
ACK	Acknowledgement (in HARQ protocols)
ACS	Adjacent Channel Selectivity
ARFCN	Absolute Radio Frequency Channel Number
AWGN	Additive White Gaussian Noise
BC	Band Category
BER	Bit Error Ratio
BS	Base Station
BTS	Base Transceiver Station
CP	Cyclic prefix
CRC	Cyclic Redundancy Check
CW	Continuous Wave
DC	Direct Current
DC-HSDPA	Dual Cell HSDPA

DTX	Discontinuous Transmission
EARFCN	E-UTRA Absolute Radio Frequency Channel Number
EDGE	Enhanced Data rates for GSM Evolution
EVM	Error Vector Magnitude
FCC	Federal Communications Commission
FDD	Frequency Division Duplex
FRC	Fixed Reference Channel
GP	Guard Period (for E-UTRA TDD operation)
GSM	Global System for Mobile Communications
HSDPA	High Speed Downlink Packet Access
ICS	In-Channel Selectivity
ITU-R	Radiocommunication Sector of the ITU
LNA	Low Noise Amplifier
MCL	Minimum Coupling Loss
MCS	Modulation and Coding Scheme
MIMO	Multiple Input Multiple Output
MS	Mobile Station
MSR	Multi-Standard Radio
OFDM	Orthogonal Frequency Division Multiplex
OOB	Out-Of-band
PA	Power Amplifier
PHS	Personal Handyphone System
QAM	Quadrature Amplitude Modulation
QPSK	Quadrature Phase-Shift Keying
RAT	Radio Access Technology
RB	Resource Block
RF	Radio Frequency
RMS	Root Mean Square (value)
RS	Reference Symbol
RX	Receiver
RRC	Root Raised Cosine
SNR	Signal-to-Noise Ratio
TDD	Time Division Duplex
TT	Test Tolerance
TX	Transmitter
UARFCN	UTRA Absolute Radio Frequency Channel Number
UE	User Equipment
UEM	operating band Unwanted Emissions Mask

---

## 4 General test conditions and declarations

### 4.1 Measurement uncertainties and test requirements

#### 4.1.1 General

The requirements of this clause apply to all applicable tests in this specification.

The minimum requirements are given in TS 37.104 [2] and the references therein. Test requirements are given in this specification or are included by reference to TS 25.141 [10], TS 25.142 [12], TS 36.141 [9] or TS 51.021 [11]. Test Tolerances for the test requirements explicitly stated in the present specification are defined in Annex C of this specification. Test Tolerances for test requirements included by reference are defined in the respective referred test specification.

Test Tolerances are individually calculated for each test. The Test Tolerances are used to relax the minimum requirements to create test requirements.

When a test requirement differs from the corresponding minimum requirement, then the Test Tolerance applied for the test is non-zero. The Test Tolerance for the test and the explanation of how the minimum requirement has been relaxed by the Test Tolerance are given in Annex C.

#### 4.1.2 Acceptable uncertainty of Test System

The maximum acceptable uncertainty of the Test System is specified below for each test defined explicitly in the present specification, where appropriate. The maximum acceptable uncertainty of the Test System for test requirements included by reference is defined in the respective referred test specification.

The Test System shall enable the stimulus signals in the test case to be adjusted to within the specified tolerance and the equipment under test to be measured with an uncertainty not exceeding the specified values. All tolerances and uncertainties are absolute values, and are valid for a confidence level of 95 %, unless otherwise stated.

A confidence level of 95% is the measurement uncertainty tolerance interval for a specific measurement that contains 95% of the performance of a population of test equipment.

For RF tests, it should be noted that the uncertainties in subclause 4.1.2 apply to the Test System operating into a nominal 50 ohm load and do not include system effects due to mismatch between the DUT and the Test System.



## 4.1.2.1 Measurement of transmitter

Table 4.1.2-1: Maximum Test System uncertainty for transmitter tests

Subclause	Maximum Test System Uncertainty	Derivation of Test System Uncertainty
6.2.1 Base Station maximum output power	±0.7 dB for UTRA and E-UTRA ±1.0 dB for GSM/EDGE	
6.6.1.5.1 Transmitter spurious emissions, Mandatory Requirements	9 kHz < f ≤ 4 GHz: ±2.0 dB 4 GHz < f ≤ 12.75 GHz: ±4.0 dB	
6.6.1.5.2 Transmitter spurious emissions, Mandatory Requirements	9 kHz < f ≤ 4 GHz: ±2.0 dB 4 GHz < f ≤ 12.75 GHz: ±4.0 dB	
6.6.1.5.3 Transmitter spurious emissions, Additional BC2 Requirement	9 kHz < f ≤ 4 GHz: ±2.0 dB 4 GHz < f ≤ 12.75 GHz: ±4.0 dB	
6.6.1.5.4 Transmitter spurious emissions, Protection of BS receiver	±3.0 dB	
6.6.1.5.5 Transmitter spurious emissions, Additional spurious emission requirements	±2.0 dB for > -60dBm ±3.0 dB for ≤ -60dBm	
6.6.1.5.6 Transmitter spurious emissions, Co-location	±3.0 dB	
6.6.2 Operating band unwanted emissions	±1.5 dB	
6.6.3 Occupied bandwidth	For E-UTRA: 1.4MHz, 3MHz Channel BW: ±30kHz 5MHz, 10MHz Channel BW: ±100kHz 15MHz, 20MHz: Channel BW: ±300kHz  For UTRA: ±100kHz	
6.7 Transmitter intermodulation (interferer requirements) This tolerance applies to the stimulus and not the measurements defined in 6.6.1, 6.6.2 and 6.6.4	The value below applies only to the interference signal and is unrelated to the measurement uncertainty of the tests (6.6.1, 6.6.2 and 6.6.4) which have to be carried out in the presence of the interferer.  ±1.0 dB	The uncertainty of interferer has double the effect on the result due to the frequency offset

## 4.1.2.2 Measurement of receiver

Table 4.1.2-2: Maximum Test System Uncertainty for receiver tests

Subclause	Maximum Test System Uncertainty	Derivation of Test System Uncertainty
[TBD]	[TBD]	[TBD]
[TBD]	[TBD]	[TBD]
[TBD]	[TBD]	[TBD]
[TBD]	[TBD]	[TBD]

## 4.1.3 Interpretation of measurement results

The measurement results returned by the Test System are compared - without any modification - against the test requirements as defined by the Shared Risk principle.

The Shared Risk principle is defined in ITU-R M.1545 [7].

The actual measurement uncertainty of the Test System for the measurement of each parameter shall be included in the test report.

The recorded value for the Test System uncertainty shall be, for each measurement, equal to or lower than the appropriate figure in subclause 4.1.2 of this specification.

If the Test System for a test is known to have a measurement uncertainty greater than that specified in subclause 4.1.2, it is still permitted to use this apparatus provided that an adjustment is made as follows.

Any additional uncertainty in the Test System over and above that specified in subclause 4.1.2 shall be used to tighten the test requirement, making the test harder to pass. (For some tests e.g. receiver tests, this may require modification of stimulus signals). This procedure (defined in Annex C) will ensure that a Test System not compliant with subclause 4.1.2 does not increase the chance of passing a device under test where that device would otherwise have failed the test if a Test System compliant with subclause 4.1.2 had been used.

## 4.2 Base Station classes

The requirements presented in the present specification apply to MSR Base Stations intended for general purpose applications. MSR BS requirements for general purpose applications are based on Wide Area scenarios.

For GSM/EDGE operation of an MSR BS, a BS intended for general purpose applications corresponds to a normal BTS, including Multicarrier BTS classes. MSR requirements for multi-RAT operation only apply for the highest GSM/EDGE static power step.

Other Base Station classes are for further study. The requirements for these may be different than those for general purpose applications, or not applicable at all.

## 4.3 Regional requirements

Some requirements in the present document may only apply in certain regions either as optional requirements, or set by local and regional regulation as mandatory requirements. It is normally not stated in the 3GPP specifications under what exact circumstances that the requirements apply, since this is defined by local or regional regulation.

Table 4.3-1 lists all requirements in the present specification that may be applied differently in different regions. There are additional regional requirements that may apply for single-RAT operation of an MSR BS. These are referenced from the present specification, but listed in the specification for the RATs concerned [2][3][4][5].

**Table 4.3-1: List of regional requirements**

Clause number	Requirement	Comments
4.5	Operating bands and Band Categories	Some bands may be applied regionally.
6.6.1.5.1	Spurious emissions (Category A)	Category A limits are mandatory for regions where Category A limits for spurious emissions, as defined in ITU-R Recommendation SM.329 [13] apply.
6.6.1.5.2	Spurious emissions (Category B)	Category B limits are mandatory for regions where Category B limits for spurious emissions, as defined in ITU-R Recommendation SM.329 [13] apply.
6.6.1.5.3	Additional requirement for BC2 (Category B)	Category B limits are mandatory for regions where Category B limits for spurious emissions, as defined in ITU-R Recommendation SM.329 [13] apply.
6.6.1.5.5	Additional spurious emissions requirements	These requirements may be applied for the protection of system operating in frequency ranges other than the MSR BS operating band. In addition to the requirements in subclauses 6.6.1.5.1, 6.6.1.5.2, 6.6.1.5.3, 6.6.1.5.4 and 6.6.1.5.5, the BS may have to comply with the applicable emission limits established by FCC Title 47 [8], when deployed in regions where those limits are applied, and under the conditions declared by the manufacturer.
6.6.1.5.6	Co-location (spurious emissions)	These requirements may be applied for the protection of other BS receivers when a BS operating in another frequency band is co-located with any BS.
6.6.2.5.4.1	Additional requirements (Operating band unwanted emissions)	In addition to the requirements in subclauses 6.6.2.5.1 and 6.6.2.5.2, the BS may have to comply with the applicable emission limits established by FCC Title 47 [8], when deployed in regions where those limits are applied and under the conditions declared by the manufacturer.
6.6.2.5.4.2	Unsynchronized operation for BC3 (Operating band unwanted emissions)	The requirements for unsynchronized TDD co-existence may apply regionally.
6.6.2.5.4.3	Protection of DTT (Operating band unwanted emissions)	The requirements for protection of DTT may apply regionally.
6.6.2.5.4.4	Co-existence with services in adjacent frequency bands (Operating band unwanted emissions)	This regional requirement may be applied for the protection of systems operating in frequency bands adjacent to band 1 as defined in clause 4.5, in geographic areas in which both an adjacent band service and UTRA and/or E-UTRA are deployed.
6.6.3.5	Occupied bandwidth	The requirement may be applied regionally. There may also be regional requirements to declare the Occupied bandwidth according to the definition.
7.5.2.5	Co-location requirement (blocking)	These requirements may be applied for the protection of the BS receiver when a BS operating in another frequency band is co-located with any BS.

## 4.4 Operating bands and band categories

MSR requirements are applicable for band definitions and band numbering as defined in the specifications TS 45.005 [6], TS25.104 [3], TS 25.105 [4] and TS 36.104 [5]. For the purpose of defining the MSR BS requirements, the operating bands are divided into three band categories as follows:

- Band Category 1 (BC1): Bands for E-UTRA FDD and UTRA FDD operation
- Band Category 2 (BC2): Bands for E-UTRA FDD, UTRA FDD and GSM/EDGE operation
- Band Category 3 (BC3): Bands for E-UTRA TDD and UTRA TDD operation

NOTE: For UTRA TDD, requirements in the present document cover the 1.28 Mcps UTRA TDD option.

The paired and unpaired bands for the three Band Categories are shown in Table 4.4-1 and 4.4-2, together with the corresponding E-UTRA, UTRA and GSM/EDGE band designations. In the present specification, the operating band of an MSR Base Stations is designated using the E-UTRA band number according to the tables.

Table 4.4-1: Paired bands in E-UTRA, UTRA and GSM/EDGE.

MSR and E-UTRA Band number	UTRA Band number	GSM/EDGE Band designation	Uplink (UL) BS receive UE transmit	Downlink (DL) BS transmit UE receive	Band category
1	I	-	1920 MHz – 1980 MHz	2110 MHz – 2170 MHz	1
2	II	PCS 1900	1850 MHz – 1910 MHz	1930 MHz – 1990 MHz	2
3	III	DCS 1800	1710 MHz – 1785 MHz	1805 MHz – 1880 MHz	2
4	IV	-	1710 MHz – 1755 MHz	2110 MHz – 2155 MHz	1
5	V	GSM 850	824 MHz – 849 MHz	869 MHz – 894 MHz	2
6 <sup>(1)</sup>	VI	-	830 MHz – 840 MHz	875 MHz – 885 MHz	1 <sup>(1)</sup>
7	VII	-	2500 MHz – 2570 MHz	2620 MHz – 2690 MHz	1
8	VIII	E-GSM	880 MHz – 915 MHz	925 MHz – 960 MHz	2
9	IX	-	1749.9 MHz – 1784.9 MHz	1844.9 MHz – 1879.9 MHz	1
10	X	-	1710 MHz – 1770 MHz	2110 MHz – 2170 MHz	1
11	XI	-	1427.9 MHz – 1447.9 MHz	1475.9 MHz – 1495.9 MHz	1
12	XII	-	698 MHz – 716 MHz	728 MHz – 746 MHz	1
13	XIII	-	777 MHz – 787 MHz	746 MHz – 756 MHz	1
14	XIV	-	788 MHz – 798 MHz	758 MHz – 768 MHz	1
15	XV	-	Reserved	Reserved	
16	XVI	-	Reserved	Reserved	
17	-	-	704 MHz – 716 MHz	734 MHz – 746 MHz	1 <sup>(2)</sup>
18	-	-	815 MHz – 830 MHz	860 MHz – 875 MHz	1 <sup>(2)</sup>
19	XIX	-	830 MHz – 845 MHz	875 MHz – 890 MHz	1
20	XX	-	832 MHz – 862 MHz	791 MHz – 821 MHz	1
21	XXI	-	1447.9 MHz – 1462.9 MHz	1495.9 MHz – 1510.9 MHz	1

NOTE 1: The band is for UTRA only.  
NOTE 2: The band is for E-UTRA only.

Table 4.4-2: Unpaired bands in E-UTRA and UTRA.

MSR and E-UTRA Band number	UTRA Band number	Uplink (UL) BS receive UE transmit	Downlink (DL) BS transmit UE receive	Band category
33	a)	1900 MHz – 1920 MHz	1900 MHz – 1920 MHz	3
34	a)	2010 MHz – 2025 MHz	2010 MHz – 2025 MHz	3
35	b)	1850 MHz – 1910 MHz	1850 MHz – 1910 MHz	3
36	b)	1930 MHz – 1990 MHz	1930 MHz – 1990 MHz	3
37	c)	1910 MHz – 1930 MHz	1910 MHz – 1930 MHz	3
38	d)	2570 MHz – 2620 MHz	2570 MHz – 2620 MHz	3
39	f)	1880 MHz – 1920 MHz	1880 MHz – 1920 MHz	3
40	e)	2300 MHz – 2400 MHz	2300 MHz – 2400 MHz	3

#### 4.4.1 Band category 1 aspects (BC1)

BC1 requirements for receiver and transmitter shall apply with a frequency offset from the lowest and highest carriers to the RF bandwidth edges ( $F_{\text{offset, RAT}}$ ) as defined in Table 4.4.1-1.

Table 4.4.1-1:  $F_{\text{offset, RAT}}$  for band category 1

RAT	$F_{\text{offset, RAT}}$
1.4, 3 MHz E-UTRA	$BW_{\text{Channel}}/2 + 200 \text{ kHz}$
5, 10, 15, 20 MHz E-UTRA	$BW_{\text{Channel}}/2$
UTRA	2.5 MHz

## 4.4.2 Band category 2 aspects (BC2)

BC2 requirements for receiver and transmitter shall apply with a frequency offset from the lowest and highest carriers to the RF bandwidth edges ( $F_{\text{offset, RAT}}$ ) as defined in Table 4.4.2-1.

**Table 4.4.2-1:  $F_{\text{offset, RAT}}$  for band category 2**

RAT	$F_{\text{offset, RAT}}$
E-UTRA	$BW_{\text{Channel}}/2$
UTRA	2.5 MHz
GSM/EDGE	200 kHz

## 4.4.3 Band category 3 aspects (BC3)

BC3 requirements for receiver and transmitter shall apply with a frequency offset from the lowest and highest carriers to the RF bandwidth edges ( $F_{\text{offset, RAT}}$ ) as defined in Table 4.4.3-1.

**Table 4.4.3-1:  $F_{\text{offset, RAT}}$  for band category 3**

RAT	$F_{\text{offset, RAT}}$
1.4, 3 MHz E-UTRA	$BW_{\text{Channel}}/2 + 200 \text{ kHz}$
5, 10, 15, 20 MHz E-UTRA	$BW_{\text{Channel}}/2$
1.28 Mcps UTRA TDD	1 MHz

## 4.5 Channel arrangement

### 4.5.1 Channel spacing

The GSM/EDGE carrier spacing is 200 kHz [5].

The nominal UTRA FDD channel spacing is 5 MHz. The nominal channel spacing is 1.6 MHz for the 1.28 Mcps UTRA TDD Option. These can be adjusted to optimise performance in a particular deployment scenario [2,3].

In E-UTRA the spacing between carriers will depend on the deployment scenario, the size of the frequency block available and the channel bandwidths. The nominal channel spacing between two adjacent E-UTRA carriers is defined as following:

$$\text{Nominal Channel spacing} = (BW_{\text{Channel}(1)} + BW_{\text{Channel}(2)})/2$$

where  $BW_{\text{Channel}(1)}$  and  $BW_{\text{Channel}(2)}$  are the channel bandwidths of the two respective E-UTRA carriers. The channel spacing can be adjusted to optimize performance in a particular deployment scenario [4].

### 4.5.2 Channel raster

The GSM/EDGE channel raster is 200 kHz for all bands [5].

The UTRA FDD and TDD channel raster is 200 kHz for all bands, which means that the centre frequency must be an integer multiple of 200 kHz. In addition a number of additional centre frequencies are specified according to [2,3], which means that the centre frequencies for these channels are shifted 100 kHz relative to the general raster.

The E-UTRA channel raster is 100 kHz for all bands, which means that the carrier centre frequency must be an integer multiple of 100 kHz [4].

### 4.5.3 Carrier frequencies and numbering

The carrier frequencies and corresponding numbering is defined for each RAT in the respective specifications TS 36.104 [5] TS 25.104 [3], TS 25.105 [4] and TS 45.005 [6]. In the context of MSR, the frequency numbering scheme for each RAT will remain.

- The E-UTRA carrier frequency numbering (EARFCN) is defined in subclause 5.7 of TS 36.104 [5].
- The UTRA FDD carrier frequency numbering (UARFCN) is defined in subclause 5.4 of TS 25.104 [3].
- The UTRA TDD carrier frequency numbering (UARFCN) is defined in subclause 5.4 of TS 25.105 [4].
- The GSM/EDGE carrier frequency numbering (ARFCN) is defined subclause 2 of TS 45.005 [6].

NOTE: The numbering schemes for UTRA FDD and TDD are not coordinated, while both are called UARFCN.

## 4.6 Manufacturer's declarations of regional and optional requirements

### 4.6.1 Operating band and frequency range

The manufacturer shall declare which operating band(s) specified in clause 4.4 that is supported by the BS under test and if applicable, which frequency ranges within the operating band(s) that the Base Station can operate in. Requirements for other operating bands and frequency ranges need not be tested.

### 4.6.2 Spurious emissions category

The manufacturer shall declare one of the following:

- a) The BS is tested against Category A limits for spurious emissions, as defined in ITU-R Recommendation SM.329 [13]. In this case
  - conformance with the spurious emissions requirements in clause 6.6.1.5.1 is mandatory, and the requirements specified in clause 6.6.1.5.2 and 6.6.1.5.3 need not be demonstrated.
- b) The BS is tested against Category B limits for spurious emissions, as defined in ITU-R Recommendation SM.329 [12]. In this case,
  - conformance with the spurious emissions requirements in clause 6.6.1.5.2 and 6.6.1.5.3 (for BC2) are mandatory, and the requirements specified in clause 6.6.1.5.1 need not be demonstrated.

### 4.6.3 Additional operating band unwanted emissions

The manufacturer shall declare whether the BS under test is intended to operate in geographic areas where the additional operating band unwanted emission limits defined in clause 6.6.2.4 of TS 37.104 [2] apply. If this is the case, conformance with the applicable emission limits shall be demonstrated.

NOTE: For the emission limits established by FCC Title 47 [12], there is no test method or requirement defined in the present specification.

For a BS declared to support Band 20 and to operate in geographic areas within the CEPT in which frequencies are allocated to broadcasting (DTT) service, the manufacturer shall additionally declare the following quantities associated with the applicable test conditions of Table 6.6.2.5.4.4-1 and information in annex G of TS 36.104 [5]:

$P_{EM,N}$  Declared emission level for channel N

$P_{10MHz}$  Maximum output Power in 10 MHz

Conformance with the declared emission level  $P_{EM,N}$  shall be demonstrated.

### 4.6.4 Co-existence with other systems

The manufacturer shall declare whether the BS under test is intended to operate in geographic areas where one or more of the systems GSM850, GSM900, DCS1800, PCS1900, UTRA FDD, UTRA TDD, E-UTRA and/or PHS operating in another band are deployed. If this is the case, conformance with the applicable test requirement for spurious emissions specified in clause 6.6.1.5.5 shall be demonstrated.

## 4.6.5 Co-location with other Base Stations

The manufacturer shall declare whether the BS under test is intended to operate co-located with Base Stations of one or more of the systems GSM850, GSM900, DCS1800, PCS1900, UTRA FDD, UTRA TDD and/or E-UTRA operating in another band. If this is the case,

- Conformance with the applicable test requirement for spurious emissions specified in clause 6.6.1.5.6 shall be demonstrated.
- Conformance with the applicable test requirement for receiver blocking specified in clause 7.5.5.2 shall be demonstrated.

## 4.7 Capability set definition and manufacturer's declarations of supported RF configurations

### 4.7.1 Definition of Capability Sets (CS)

Capability set is defined as the BS capability to support certain RAT combinations.

The manufacturer shall declare the supported capability set(s) according to Table 4.7.1-1.

**Table 4.7.1-1 Capability sets**

Capability Set supported by the BS	CS1	CS2	CS3	CS4	CS5	CS6
Supported RATs	UTRA (MC)	E-UTRA (MC)	UTRA, E-UTRA	GSM, UTRA	GSM, E-UTRA	GSM, UTRA, E-UTRA
Supported configurations	SR UTRA (SC, MC)	SR E-UTRA (SC, MC)	MR UTRA + E-UTRA SR UTRA (SC, MC) SR E-UTRA (SC, MC)	MR GSM + UTRA SR GSM (MCBTS) SR UTRA (SC, MC)	MR GSM + E-UTRA SR GSM (MCBTS) SR E-UTRA (SC, MC)	MR GSM + UTRA + E-UTRA MR GSM + UTRA MR GSM + E-UTRA MR UTRA + E-UTRA SR GSM (MCBTS) SR UTRA (SC, MC) SR E-UTRA (SC, MC)
Applicable BC	BC1, BC2 or BC3	BC1, BC2 or BC3	BC1, BC2 or BC3	BC2	BC2	BC2
NOTE:	MC denotes multi-carrier in single RAT; SC denotes single carrier; MR denotes multi-RAT; SR denotes single-RAT					

The applicable test configurations for each RF requirement are defined in sub-clause 5.1 and 5.2 for the declared capability set(s).

- NOTE: Not every supported configuration within a CS is tested, but the tables in sub-clause 5.1 and 5.2 provide a judicious choice among the supported configurations and test configurations to ensure proper test coverage.

## 4.7.2 Manufacturer's declarations of supported RF configurations

The manufacturer shall declare which operational configurations the BS supports by declaring the following parameters:

a) General Parameters:

- The supported operating bands defined in subclause 4.4.
- The frequency range within the above frequency band(s) supported by the BS.
- Supported capability set
- The maximum RF bandwidth supported by a MSR BS within an operating band when the BS is configured with carriers of different RATs.
- The rated total output power as a sum over all RATs
- Maximum supported power difference between carriers
- Total number of supported carriers

If the rated total output power and total number of supported carriers are not simultaneously supported in Multi-RAT operations, the manufacturer shall declare the following additional parameters:

- The reduced number of supported carriers at the rated total output power in Multi-RAT operations (i.e. < total number of supported carriers)
- The reduced total output power at the total number of supported carriers in Multi-RAT operations (i.e. < rated total output power)

b) Parameters related to operation of GSM:

- The maximum number of supported GSM carriers
- The maximum RF bandwidth supported by the MSR BS when configured with GSM carriers only
- The rated output power per GSM carrier for each supported number of GSM carriers up to the maximum, for the case that all carriers are operated at the same nominal output power. The declaration shall be given for each supported modulation.

c) Parameters related to operation of UTRA:

- The maximum number of supported UTRA carriers
- The maximum RF bandwidth supported by the MSR BS when configured with UTRA carriers only
- The rated output power for UTRA as a sum of all UTRA carriers
- The rated output power per UTRA carrier

d) Parameters related to operation of E-UTRA:

- Which of the E-UTRA channel bandwidths specified in TS 36.104 [5] clause 5.6 are supported
- The maximum number of supported E-UTRA carriers
- The maximum RF bandwidth supported by the MSR BS when configured with E-UTRA carriers only
- The rated output power for E-UTRA as a sum of all E-UTRA carriers
- The rated output power per E-UTRA carrier



## 4.8 MSR test configurations

The test configurations shall be constructed using the methods defined below subject to the parameters declared by the manufacturer as listed in subclause 4.7.

For test configurations used in receiver tests only the outermost carriers need to be generated by the test equipment.

The applicable test models for generation of the carrier transmit test signal are defined in clause 4.9.2.

### 4.8.1 TC1: UTRA multicarrier operation

The purpose of TC1 is to test UTRA multi-carrier aspects.

#### 4.8.1.1 TC1a generation

TC1a is constructed using the following method:

- The RF bandwidth shall be the declared maximum supported RF bandwidth.
- Place two UTRA FDD carriers adjacent to the high and low edge of the RF bandwidth. The specified  $F_{\text{Offset-RAT}}$  shall apply.
- For transmitter tests, alternately place a UTRA FDD carrier adjacent to the already placed carriers at the low and high edge of the RF bandwidth until there is no more space to fit a carrier or the BS does not support more carriers. The nominal carrier spacing defined in clause 4.5.1 shall apply.

#### 4.8.1.2 TC1b generation

TC1b is constructed using the following method:

- The RF bandwidth shall be the declared maximum supported RF bandwidth.
- Place two UTRA TDD carriers adjacent to the high and low edge of the RF bandwidth. The specified  $F_{\text{Offset-RAT}}$  shall apply.
- For transmitter tests, alternately place a UTRA TDD carrier adjacent to the already placed carriers at the low and high edge of the RF bandwidth until there is no more space to fit a carrier or the BS does not support more carriers. The nominal carrier spacing defined in clause 4.5.1 shall apply.

#### 4.8.1.3 TC1 power allocation

Set the power of each carrier to the same power so that the sum of the carrier powers equals the rated output power for UTRA according to the manufacturer's declaration in sub clause 4.7.2 c).

### 4.8.2 TC2: E-UTRA multicarrier operation

The purpose of the TC2 is to test E-UTRA multi-carrier aspects.

#### 4.8.2.1 TC2 generation

TC2 is constructed using the following method:

- The RF bandwidth shall be the declared maximum supported RF bandwidth.
- Select the narrowest supported E-UTRA carrier and place it adjacent to the low edge of the RF bandwidth. Place a 5 MHz E-UTRA carrier adjacent to the high edge of the RF bandwidth. The specified  $F_{\text{Offset-RAT}}$  shall apply.
- For transmitter tests, select as many 5 MHz E-UTRA carriers that the BS supports and that fit in the rest of the RF bandwidth. Place the carriers adjacent to each other starting from the high RF bandwidth edge. The nominal carrier spacing defined in clause 4.5.1 shall apply. The specified  $F_{\text{Offset-RAT}}$  shall apply.

- If 5 MHz E-UTRA carriers are not supported by the BS the narrowest supported channel BW shall be selected instead.

#### 4.8.2.2 TC2 power allocation

Set the power of each carrier to the same power so that the sum of the carrier powers equals the rated output power for E-UTRA according to the manufacturer's declaration in sub clause 4.7.2 d).

#### 4.8.3 TC3: UTRA and E-UTRA multi RAT operation

The purpose of TC3 is to test UTRA and E-UTRA multi-RAT aspects.

If the rated total output power and total number of supported carriers are not simultaneously supported in Multi-RAT operations, two instances of TC3 shall be generated using the following values for rated total output power and the total number of supported carriers:

- 1) The rated total output power and the reduced number of supported carriers at the rated total output power in Multi-RAT operations
- 2) The reduced total output power at the total number of supported carriers in Multi-RAT operations and the total number of supported carriers.

Tests that use TC3 shall be performed using both instances 1) and 2) of TC3.

##### 4.8.3.1 TC3a generation

TC3a is constructed using the following method:

- Select an FDD UTRA carrier to be placed at the low RF Bandwidth edge. The specified  $F_{\text{Offset-RAT}}$  shall apply.
- Place a 5 MHz E-UTRA carrier at the high RF bandwidth edge. If that is not possible use the narrowest E-UTRA carrier supported by the BS. The specified  $F_{\text{Offset-RAT}}$  shall apply.
- For transmitter tests, alternately add FDD UTRA carriers at the low end and 5 MHz E-UTRA carriers at the high end adjacent to the already placed carriers until the RF bandwidth is filled or the total number of supported carriers is reached. The nominal carrier spacing defined in clause 4.5.1 shall apply.

##### 4.8.3.2 TC3b generation

TC3b is constructed using the following method:

- The RF bandwidth shall be the declared maximum supported RF bandwidth.
- Select a UTRA TDD carrier to be placed at the low RF Bandwidth edge. The specified  $F_{\text{Offset-RAT}}$  shall apply.
- The RF bandwidth shall be the declared maximum supported RF bandwidth.
- Place a 5 MHz E-UTRA carrier at the high RF bandwidth edge. If that is not possible use the narrowest E-UTRA carrier supported by the BS. The specified  $F_{\text{Offset-RAT}}$  shall apply.
- For transmitter tests, alternately add UTRA TDD carriers at the low end and 5 MHz E-UTRA carriers at the high end adjacent to the already placed carriers until the RF bandwidth is filled or the total number of supported carriers is reached. The nominal carrier spacing defined in clause 4.5.1 shall apply.

##### 4.8.3.3 TC3 power allocation

Set the power of each carrier to the same power so that the sum of the carrier powers equals the total rated output power according to the manufacturer's declaration in subclause 4.7.2 c) and d).

#### 4.8.4 TC4: BC2 transmitter operation

The purpose of TC4 is to test multi-RAT operations with GSM for the transmitter.

If the rated total output power and total number of supported carriers are not simultaneously supported in Multi-RAT operations, two instances of TC4 shall be generated using the following values for rated total output power and the total number of supported carriers:

- 1) The rated total output power and the reduced number of supported carriers at the rated total output power in Multi-RAT operations
- 2) The reduced rated total output power at the total number of supported carriers in Multi-RAT operations and the total number of supported carriers.

Tests that use TC4 shall be performed using both instances 1) and 2) of TC4, except tests for modulation accuracy in which TC4 according to 2) shall be used.

#### 4.8.4.1 TC4a generation

TC4a is only applicable for a BS that supports UTRA and GSM. TC4a is constructed using the following method:

- The RF bandwidth shall be the declared maximum supported RF bandwidth.
- Place a GSM carrier at the high end and a GSM carrier at the low end of the RF bandwidth. The specified  $F_{\text{Offset-RAT}}$  shall apply..
- Place two UTRA FDD carriers in the middle of the RF bandwidth. If two UTRA FDD carriers do not fit, place only one.
- Add GSM carriers at the edges using 600 kHz spacing until no more GSM carriers are supported or no more GSM carriers fit.
- Add additional UTRA FDD carriers in the middle if possible.

NOTE: Further details on the method for BS supporting many carriers is FFS.

#### 4.8.4.2 TC4b generation

TC4b is only applicable for a BS that supports E-UTRA and GSM. TC4b is constructed using the following method:

- The RF bandwidth shall be the declared maximum supported RF bandwidth.
- Place a GSM carrier at the high end and a GSM carrier at the low end of the RF bandwidth. The specified  $F_{\text{Offset-RAT}}$  shall apply.
- Place two 5 MHz E-UTRA carriers in the middle of the RF bandwidth. If the BS does not support 5 MHz channel BW use the narrowest supported BW, if two carriers do not fit place only one carrier.
- Add GSM carriers at the edges using 600 kHz spacing until no more GSM carriers are supported or no more GSM carriers fit.
- Add additional E-UTRA carriers of the same bandwidth as the already allocated E-UTRA carriers in the middle if possible.

NOTE: Further details on the method for BS supporting many carriers is FFS.

#### 4.8.4.3 TC4c generation

TC4c is only applicable for a BS that supports UTRA, E-UTRA and GSM. TC4c is constructed using the following method:

- The RF bandwidth shall be the declared maximum supported RF bandwidth.
- Place a GSM carrier at the high end and a GSM carrier at the low end of the RF bandwidth. The specified  $F_{\text{Offset-RAT}}$  shall apply.
- Place one 5 MHz E-UTRA carrier and one UTRA carrier in the middle of the RF bandwidth. If the BS does not support 5 MHz E-UTRA channel BW use the narrowest supported BW.

- Add GSM carriers at the edges using 600 kHz spacing until no more GSM carriers are supported or no more GSM carriers fit.
- Add additional UTRA and E-UTRA carriers in the middle if possible. For E-UTRA the same bandwidth as the already allocated E-UTRA carriers shall be used.

NOTE: Further details on the method for BS supporting many carriers is FFS.

#### 4.8.4.4 TC4d generation

TC4d is only applicable for a BS that supports UTRA. TC4d is only applicable when [the declared RF bandwidth for GSM is not equal to the declared RF bandwidth for multi-RAT operations and] the frequency range within the frequency band supported by the BS is a subset of the operating band, or when the maximum supported RF bandwidth covers the entire operating band. TC4d is constructed using the following method:

- The RF bandwidth shall be 600 kHz less than the declared maximum supported RF bandwidth.
- The RF bandwidth shall be adjacent to the high end of the frequency range supported by the BS.
- Place a GSM carrier at the low end of the RF bandwidth. Add one GSM carrier at the low end using 600 kHz spacing. The specified  $F_{\text{Offset-RAT}}$  shall apply.
- Put one UTRA carrier adjacent to the high end of the RF bandwidth. The specified  $F_{\text{Offset-RAT}}$  shall apply.

#### 4.8.4.5 TC4e generation

TC4e is only applicable for a BS that supports E-UTRA. TC4e is only applicable when [the declared RF bandwidth for GSM is not equal to the declared RF bandwidth for multi-RAT operations and] the frequency range within the frequency band supported by the BS is a subset of the operating band, or when the maximum supported RF bandwidth covers the entire operating band. TC4e is constructed using the following method:

- The RF bandwidth shall be 600 kHz less than the declared maximum supported RF bandwidth.
- The RF bandwidth shall be adjacent to the high end of the frequency range supported by the BS.
- Place a GSM carrier at the low end of the RF bandwidth. Add one GSM carrier at the low end using 600 kHz spacing. The specified  $F_{\text{Offset-RAT}}$  shall apply.
- Put one 5 MHz E-UTRA carrier adjacent to the high end of the RF bandwidth. If the BS does not support 5 MHz channel BW use the narrowest supported BW. The specified  $F_{\text{Offset-RAT}}$  shall apply.

#### 4.8.4.6 TC4 power allocation

- a) Unless otherwise stated, set each carrier to the same power so that the sum of the carrier powers equals the rated total output power according to manufacturer's declarations in clause 4.7.2 a)
- b) In case that TC4 is configured for testing modulation quality, the power allocated per carrier for the RAT on which modulation quality is measured shall be the highest possible for the given modulation configuration according to the manufacturer's declarations in subclause 4.7.2, unless that power is higher than the level defined by case a). The power of the remaining carriers from other RAT(s) shall be set to the same level as in case a).

If in the case of b) the power of one RAT needs to be reduced in order to meet the manufacture's declaration the power in the other RAT(s) does not need to be increased.

### 4.8.5 TC5: BC2 receiver operation

#### 4.8.5.1 TC5a generation

TC5a is constructed using the following method:

- The RF bandwidth shall be the declared maximum supported RF bandwidth.

- Place a GSM carrier at the low RF bandwidth edge. The specified  $F_{\text{Offset-RAT}}$  shall apply.
- Place a UTRA FDD carrier at the high RF bandwidth edge. The specified  $F_{\text{Offset-RAT}}$  shall apply.

#### 4.8.5.2 TC5b generation

TC5b is constructed using the following method:

- The RF bandwidth shall be the declared maximum supported RF bandwidth.
- Place a GSM carrier at the low RF bandwidth edge. The specified  $F_{\text{Offset-RAT}}$  shall apply.
- Place a 5MHz E-UTRA carrier at the high RF bandwidth edge. If the BS does not support 5 MHz channel BW select the narrowest supported channel BW. The specified  $F_{\text{Offset-RAT}}$  shall apply.

### 4.8.6 TC6: Single carrier for receiver tests

#### 4.8.6.1 TC6a generation

TC6a is constructed using the following method:

- Place a single UTRA carrier in the middle of the maximum supported RF bandwidth.

#### 4.8.6.2 TC6b generation

TC6b is constructed using the following method:

- Place the narrowest supported E-UTRA carrier in the middle of the maximum supported RF bandwidth.

#### 4.8.6.3 TC6c generation

TC6c is constructed using the following method:

- Place a single UTRA TDD carrier in the middle of the maximum supported RF bandwidth.

## 4.9 RF channels and test models

### 4.9.1 RF channels

Many tests in this TS are performed with the maximum RF bandwidth located at the bottom, middle and top of the supported frequency range in the operating band. These are denoted as  $B_{\text{RFBW}}$  (bottom),  $M_{\text{RFBW}}$  (middle) and  $T_{\text{RFBW}}$  (top).

Unless otherwise stated, the test shall be performed at  $B_{\text{RFBW}}$ ,  $M_{\text{RFBW}}$  and  $T_{\text{RFBW}}$  defined as following:

$B_{\text{RFBW}}$ : maximum RF bandwidth located at the bottom of the supported frequency range in the operating band.

$M_{\text{RFBW}}$ : maximum RF bandwidth located in the middle of the supported frequency range in the operating band.

$T_{\text{RFBW}}$ : maximum RF bandwidth located at the top of the supported frequency range in the operating band.

For the test of certain RF requirements the present specification refers to test procedures defined in the single-RAT specifications. In this case, the interpretation of the RF channels to be tested shall be according to the following definitions:

B: maximum RF bandwidth located at the bottom of the supported frequency range in the operating band, the channel to be tested located at the bottom of the maximum RF bandwidth

M: maximum RF bandwidth located in the middle of the supported frequency range in the operating band, the channel to be tested located in the middle of the maximum RF bandwidth

T: maximum RF bandwidth located at the top of the supported frequency range in the operating band, the channel to be tested located at the top of the maximum RF bandwidth

For the case of multi-carrier tests, where supported carriers are numbered from 1 to N, the interpretation of M for test purposes shall be as follows:

For testing at M,

- if the number N of carriers supported is odd, the carrier  $(N+1)/2$  shall be centred on M,
- if the number N of carriers supported is even, the carrier  $N/2$  shall be centred on M.

When a test is performed by a test laboratory, the position of  $B_{\text{RFBW}}$ ,  $M_{\text{RFBW}}$  and  $T_{\text{RFBW}}$  in the operating band and the channel numbers to be used for RF channels B, M and T shall be specified by the laboratory. The laboratory may consult with operators, the manufacturer or other bodies.

## 4.9.2 Test models

- a) Unless otherwise stated, carriers within MSR test configurations used for transmitter tests shall be configured as follows:
  - UTRA FDD carriers shall be configured according to TM1 as defined in TS 25.141 [10] subclause 6.1.1.1.
  - UTRA TDD carriers shall be configured according to Table 6.1A as defined in TS 25.142 [12] subclause 6.2.4.1.2.
  - E-UTRA carriers shall be configured according to E-TM1 as defined in TS 36.141 [9] subclause 6.1.1.1.
  - GSM carriers shall use GMSK modulation as defined in TS 51.021 [11] clause 6.2.2.
- b) The configuration of the carriers in test configurations used for testing modulation quality and frequency error shall be as follows:
  - For the case that modulation accuracy is measured for UTRA FDD, the UTRA FDD carriers shall be configured according to the supported TM1, TM4 and if HS-PDSCH transmission using 16QAM is supported also TM5 as defined in TS 25.141 [10] subclause 6.1.1.1, 6.1.1.4 and 6.1.1.4A whilst any remaining carriers from other RAT(s) shall be configured according to a).
  - For the case that modulation accuracy is measured for UTRA TDD, the UTRA TDD carriers shall be configured according to the supported modulation in Table 6.2A, Table 6.39A, Table 6.39B, Table 6.39C, Table 6.39D, Table 6.40A, Table 6.40B, Table 6.41A, Table 6.41B as defined in TS 25.142 [12] subclause 6.3.4, 6.8.1, 6.8.2 and 6.8.3 whilst any remaining carriers from other RAT(s) shall be configured according to a).
  - For the case that modulation accuracy is measured for E-UTRA, the E-UTRA carriers shall be configured according to the supported E-TM3.1, E-TM3.2, E-TM3.3 and E-TM2 as defined in TS 36.141 [9] subclause 6.1.1.4, 6.1.1.5, 6.1.1.6 and 6.1.1.3 whilst any remaining carriers from other RAT(s) shall be configured according to a).
  - For the case that modulation accuracy is measured for GSM, the GSM carriers shall be configured for the supported modulation according to TS 51.021 [11] clause 6.2.2 whilst any remaining carriers from other RAT(s) shall be configured according to a).

For the test of certain RF requirements clause 5 refers to the test configurations as defined in the single-RAT specifications. In this case, the transmitter test signals and test models as defined within the referred test specification for the RF requirement shall be used.

## 4.10 BS configurations

### 4.10.1 Transmit configurations

Unless otherwise stated, the transmitter characteristics in clause 6 are specified at the BS antenna connector (test port A) with a full complement of transceivers for the configuration in normal operating conditions. If any external apparatus

such as a TX amplifier, a filter or the combination of such devices is used, requirements apply at the far end antenna connector (test port B).

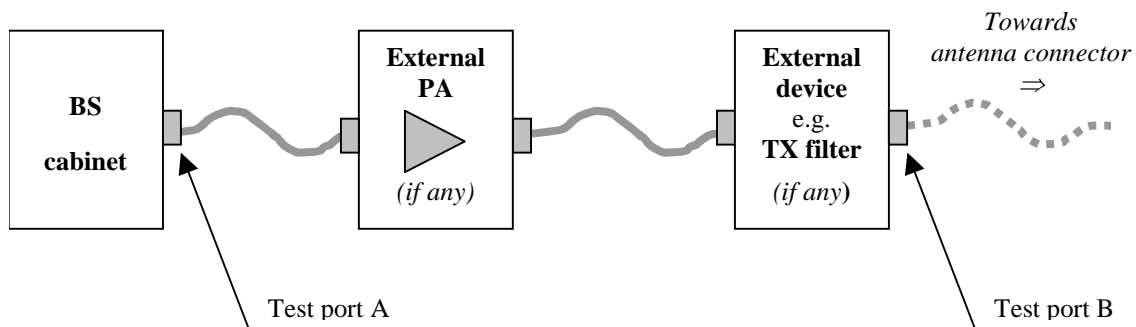

Figure 4.10.1-1: Transmitter test ports

4.10.1.1 Multi-carrier transmission with multiple transmitter antenna connectors, transmit diversity and MIMO transmission

Unless otherwise stated, for the tests in clause 6 of the present document, the requirement applies for each transmitter antenna connector in the case of multi-carrier transmission with multiple transmitter antenna connectors, transmit diversity, DB-DC-HSDPA or MIMO transmission.

Transmitter requirements are tested at the antenna connector, with the remaining antenna connector(s) being terminated. If the manufacturer has declared the transmitter paths to be equivalent, it is sufficient to measure the signal at any one of the transmitter antenna connectors.

4.10.2 Receive configurations

Unless otherwise stated, the receiver characteristics in clause 7 are specified at the BS antenna connector (test port A) with a full complement of transceivers for the configuration in normal operating conditions. If any external apparatus such as a RX amplifier, a filter or the combination of such devices is used, requirements apply at the far end antenna connector (test port B).

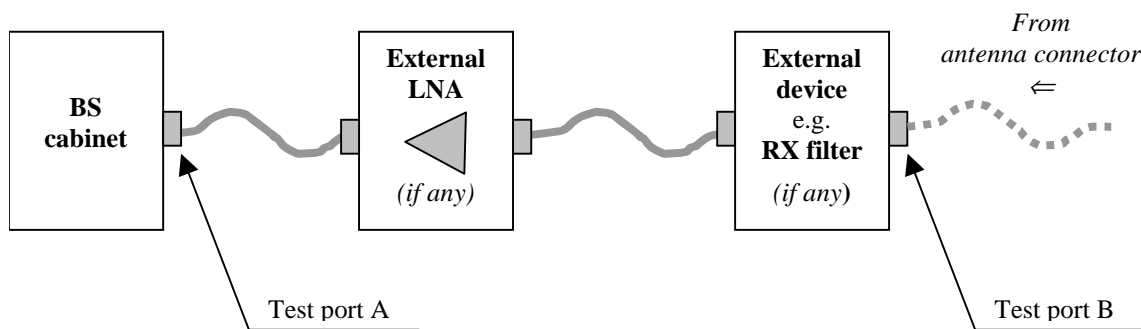

Figure 4.10.2-1: Receiver test ports

4.10.2.1 Multi-carrier reception with multiple receiver antenna connectors, receiver diversity

For the tests in clause 7 of the present document, the requirement applies at each receiver antenna connector for receivers with antenna diversity or in the case of multi-carrier reception with multiple receiver antenna connectors.

Receiver requirements are tested at the antenna connector, with the remaining receiver(s) disabled or their antenna connector (s) being terminated. If the manufacturer has declared the receiver paths to be equivalent, it is sufficient to apply the specified test signal at any one of the receiver antenna connectors.

### 4.10.3 Duplexers

The requirements of the present document shall be met with a duplexer fitted, if a duplexer is supplied as part of the BS.

NOTE: The present release of this specification does not contain test requirements for the case that the duplexer is supplied as an option by the manufacturer. This is left for future releases.

### 4.10.4 Power supply options

If the BS is supplied with a number of different power supply configurations, it may not be necessary to test RF parameters for each of the power supply options, provided that it can be demonstrated that the range of conditions over which the equipment is tested is at least as great as the range of conditions due to any of the power supply configurations.

This applies particularly if a BS contains a DC rail which can be supplied either externally or from an internal mains power supply. In this case, the conditions of extreme power supply for the mains power supply options can be tested by testing only the external DC supply option. The range of DC input voltages for the test should be sufficient to verify the performance with any of the power supplies, over its range of operating conditions within the BS, including variation of mains input voltage, temperature and output current.

### 4.10.5 Ancillary RF amplifiers

The requirements of the present document shall be met with the ancillary RF amplifier fitted. At tests according to clauses 6 and 7 for TX and RX respectively, the ancillary amplifier is connected to the BS by a connecting network (including any cable(s), attenuator(s), etc.) with applicable loss to make sure the appropriate operating conditions of the ancillary amplifier and the BS. The applicable connecting network loss range is declared by the manufacturer. Other characteristics and the temperature dependence of the attenuation of the connecting network are neglected. The actual attenuation value of the connecting network is chosen for each test as one of the applicable extreme values. The lowest value is used unless otherwise stated.

Sufficient tests should be repeated with the ancillary amplifier fitted and, if it is optional, without the ancillary RF amplifier to verify that the BS meets the requirements of the present document in both cases.

When testing, the following tests shall be repeated with the optional ancillary amplifier fitted according to Table 4.10.5-1, where x denotes that the test is applicable:

**Table 4.10.5-1 Tests applicable to ancillary RF Amplifiers**

Receiver Tests	Subclause	TX amplifier only	RX amplifier only	TX/RX amplifiers combined (Note)
	7.2		X	X
	7.4		X	X
	7.5		X	X
	7.6		X	X
	7.7		X	
Transmitter Tests	6.2	X		X
	6.6.1	X		X
	6.6.2	X		X
	6.6.3	X		X
	6.6.4	X		X
	6.7	X		X

NOTE: Combining can be by duplex filters or any other network. The amplifiers can either be in RX or TX branch or in both. Either one of these amplifiers could be a passive network.

In test according to subclauses 6.2 and 7.2 highest applicable attenuation value is applied.



## 4.10.6 BS with integrated Iuant BS modem

Unless otherwise stated, for the tests in the present document, the integrated Iuant BS modem shall be switched off. Spurious emissions according to clauses 6.6.4 and 7.7 shall be measured only for frequencies above 20MHz with the integrated Iuant BS modem switched on.

## 4.10.7 BS using antenna arrays

A BS may be configured with a multiple antenna port connection for some or all of its transceivers or with an antenna array related to one cell (not one array per transceiver). This subclause applies to a BS which meets at least one of the following conditions:

- the transmitter output signals from one or more transceiver appear at more than one antenna port; or
- there is more than one receiver antenna port for a transceiver or per cell and an input signal is required at more than one port for the correct operation of the receiver thus the outputs from the transmitters as well as the inputs to the receivers are directly connected to several antennas (known as "aircombining"); or
- transmitters and receivers are connected via duplexers to more than one antenna.

In case of diversity or spatial multiplexing, multiple antennas are not considered as an antenna array.

If a BS is used, in normal operation, in conjunction with an antenna system which contains filters or active elements which are necessary to meet the BS requirements, the conformance tests may be performed on a system comprising the BS together with these elements, supplied separately for the purposes of testing. In this case, it must be demonstrated that the performance of the configuration under test is representative of the system in normal operation, and the conformance assessment is only applicable when the BS is used with the antenna system.

For conformance testing of such a BS, the following procedure may be used.

### 4.10.7.1 Receiver tests

For each test, the test signals applied to the receiver antenna connectors shall be such that the sum of the powers of the signals applied equals the power of the test signal(s) specified in the test.

An example of a suitable test configuration is shown in figure 4.10.7.1-1.

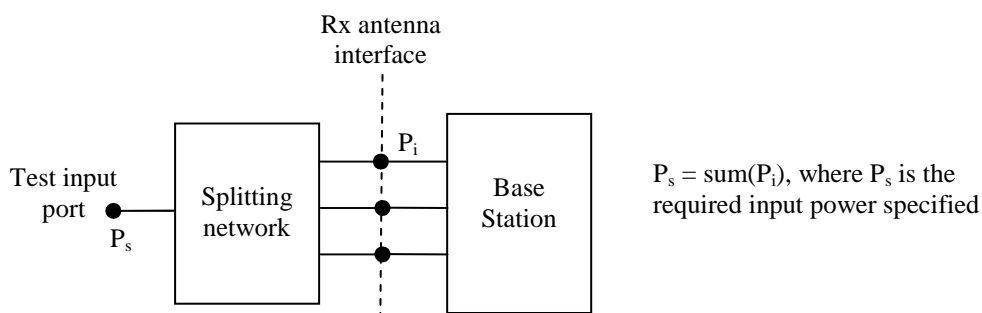

**Figure 4.10.7.1-1: Receiver test set-up**

For spurious emissions from the receiver antenna connector, the test may be performed separately for each receiver antenna connector.

### 4.10.7.2 Transmitter tests

For each test, the test signals applied to the transmitter antenna connectors ( $P_i$ ) shall be such that the sum of the powers of the signals applied equals the power of the test signal(s) ( $P_s$ ) specified in the test. This may be assessed by separately measuring the signals emitted by each antenna connector and summing the results, or by combining the signals and performing a single measurement. The characteristics (e.g. amplitude and phase) of the combining network should be such that the power of the combined signal is maximised.

An example of a suitable test configuration is shown in figure 4.10.7.2-1.

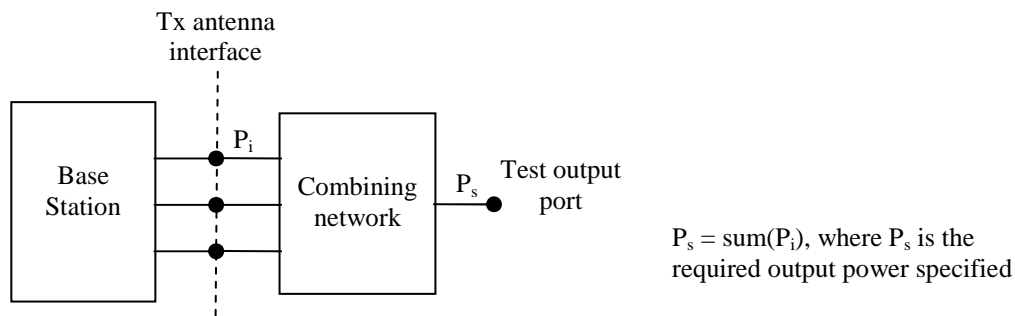

**Figure 4.10.7.2-1: Transmitter test set-up**

For Intermodulation attenuation, the test may be performed separately for each transmitter antenna connector.

## 4.11 Format and interpretation of tests

Each test in the following clauses has a standard format:

### X Title

All tests are applicable to all equipment within the scope of the present document, unless otherwise stated.

#### X.1 Definition and applicability

This subclause gives the general definition of the parameter under consideration and specifies whether the test is applicable to all equipment or only to a certain subset. Required manufacturer declarations may be included here.

#### X.2 Minimum requirement

This subclause contains the reference to the subclause to the 3GPP reference (or core) specification which defines the minimum requirement.

#### X.3 Test purpose

This subclause defines the purpose of the test.

#### X.4 Method of test

##### X.4.1 Initial conditions

This subclause defines the initial conditions for each test, including the test environment, the RF channels to be tested and the basic measurement set-up. For the test of certain RF requirements the present specification refers to the test method of the single-RAT specifications. In this case, the initial conditions as defined within the referred test specification for the RF requirement shall be used.

##### X.4.2 Procedure

This subclause describes the steps necessary to perform the test and provides further details of the test definition like point of access (e.g. test port), domain (e.g. frequency-span), range, weighting (e.g. bandwidth), and algorithms (e.g. averaging). For the test of certain RF requirements the present specification refers to the test method of the single-RAT specifications. In this case, the test procedure as defined within the referred test specification for the RF requirement shall be used.

#### X.5 Test requirement

This subclause defines the pass/fail criteria for the equipment under test. See subclause 4.1.3 Interpretation of measurement results. For the test of certain RF requirements the present specification refers to the requirements of the

single-RAT specifications. In this case, the test requirement as defined within the referred test specification for the RF requirement shall be used.

---

## 5 Applicability of requirements and test configurations

The present clause defines for each RF test requirement the set of mandatory test configurations which shall be used for demonstrating conformance. This is specified in the Table 5.1-2 for single-RAT Multi-carrier and Table 5.1-1 for multi-RAT Base Stations.

Requirements apply according to the declared RAT Capability Set (CS) of the MSR Base Station and the Band Category of the declared operating band (BC1, BC2 or BC3), as listed in the heading of each table. Some RF requirements listed in the tables may not be mandatory or they may apply only regionally. This is further specified for each requirement in clause 6 and 7, and in Table 4.3-1.

For a declared RAT Capability Set (CS), only the requirements listed in the column for that CS apply. Requirements listed under CS other than the declared CS(s) need not be tested.

For some of the RF test requirements entries within Tables 5.1-1 and 5.1-2 refer to the single-RAT specifications; this is denoted by "(TS 25.141)", "(TS 25.142)", "(TS 36.141)" or "(TS 51.021)". In this case the following shall apply:

- transmitter test signals and test models as defined within the referred test specification shall be used, see clause 4.9.2. For some RF requirements this comprises a mandatory test case in addition to a test case using the MSR test configurations defined in clause 4.8.
- for some RF requirements the initial conditions and test procedure as defined within the referred single-RAT test specification for the RF requirement shall be used. This is specified in further detail in clauses 6, 7 and 8 of the present document.
- for some RF requirements the test requirement as defined within the referred single-RAT test specification for the RF requirement shall be used. This is specified in further detail in clauses 6, 7 and 8 of the present document. In this case (see clause 4.1):
  - The maximum acceptable uncertainty of the Test System for test requirements are defined in the respective referred test specification
  - Test Tolerances are defined in the respective referred test specification.

## 5.1 Multi-RAT capable Base Stations

Table 5.1-1: Test configurations for capability sets for Multi-RAT capable BS

Capability Set	UTRA + E-UTRA (CS 3)			GSM+ UTRA (CS 4)	GSM + E-UTRA (CS 5)	GSM + UTRA + E-UTRA (CS 6)
	BC1	BC2	BC3	BC2	BC2	BC2
<b>6.2 Base Station output power</b>	-	-	-	-	-	-
6.2.1 Minimum requirement	TC3a	TC3a	TC3b	TC4a	TC4b	TC4c
6.2.2 Additional requirement (only for band 34)	N/A	N/A	Compliance stated by manufacturer declaration	N/A	N/A	N/A
6.2.3 E-UTRA minimum requirement for DL RS power	(TS 36.141)	(TS 36.141)	(TS 36.141)	N/A	(TS 36.141)	(TS 36.141)
6.2.4 UTRA FDD minimum requirement for primary CPICH power	(TS 25.141)	(TS 25.141)	N/A	(TS 25.141)	N/A	(TS 25.141)
6.2.5 UTRA TDD minimum requirement for primary CCPCCH power	N/A	N/A	(TS 25.142)	N/A	N/A	N/A
<b>6.3 Output power dynamics</b>	-	-	-	-	-	-
6.3.1 E-UTRA minimum requirement	(TS 36.141)	(TS 36.141)	(TS 36.141)	N/A	(TS 36.141)	(TS 36.141)
6.3.2 UTRA FDD minimum requirement	(TS 25.141)	(TS 25.141)	N/A	(TS 25.141)	N/A	(TS 25.141)
6.3.3 UTRA TDD minimum requirement	N/A	N/A	(TS 25.142)	N/A	N/A	N/A
6.3.4 GSM/EDGE minimum requirement	N/A	N/A	N/A	(TS 51.021)	(TS 51.021)	(TS 51.021)
<b>6.4 Transmit ON/OFF power</b>	-	-	-	-	-	-
6.4.1 Transmitter OFF power	N/A	N/A	TC3b	N/A	N/A	N/A
6.4.2 Transmitter transient period	N/A	N/A	TC3b	N/A	N/A	N/A
<b>6.5 Transmitted signal quality</b>	-	-	-	-	-	-
<b>6.5.1 Modulation quality</b>	-	-	-	-	-	-
6.5.1.1 E-UTRA minimum requirement	TC3a	TC3a	TC3b	N/A	TC4b	TC4c
6.5.1.2 UTRA FDD minimum requirement	TC3a	TC3a	N/A	TC4a	N/A	TC4c
6.5.1.3 UTRA TDD minimum requirement	N/A	N/A	TC3b	N/A	N/A	N/A
6.5.1.4 GSM/EDGE	N/A	N/A	N/A	TC4a	TC4b	TC4c

Capability Set	UTRA + E-UTRA (CS 3)			GSM+ UTRA (CS 4)	GSM + E-UTRA (CS 5)	GSM + UTRA + E-UTRA (CS 6)
	BC1	BC2	BC3	BC2	BC2	BC2
minimum requirement						
<b>6.5.2 Frequency error</b>	-	-	-	-	-	-
6.5.2.1 E-UTRA minimum requirement	Same TC as used in 6.5.1	Same TC as used in 6.5.1	Same TC as used in 6.5.1	N/A	Same TC as used in 6.5.1	Same TC as used in 6.5.1
6.5.2.2 UTRA FDD minimum requirement	Same TC as used in 6.5.1	Same TC as used in 6.5.1	N/A	Same TC as used in 6.5.1	N/A	Same TC as used in 6.5.1
6.5.2.3 UTRA TDD minimum requirement	N/A	N/A	Same TC as used in 6.5.1	N/A	N/A	N/A
6.5.2.4 GSM/EDGE minimum requirement	N/A	N/A	N/A	Same TC as used in 6.5.1	Same TC as used in 6.5.1	Same TC as used in 6.5.1
<b>6.5.3 Time alignment between transmitter branches</b>	-	-	-	-	-	-
6.5.3.1 E-UTRA minimum requirement	(TS 36.141)	(TS 36.141)	(TS 36.141)	N/A	(TS 36.141)	(TS 36.141)
6.5.3.2 UTRA FDD minimum requirement	(TS 25.141)	(TS 25.141)	N/A	(TS 25.141)	N/A	(TS 25.141)
6.5.3.3 UTRA TDD minimum requirement	N/A	N/A	(TS 25.142)	N/A	N/A	N/A
<b>6.6 Unwanted emissions</b>	-	-	-	-	-	-
<b>6.6.1 Transmitter spurious emissions</b>	-	-	-	-	-	-
6.6.1.1.1 Minimum requirement (Category A)	TC3a	TC3a	TC3b	TC4a	TC4b	TC4c
6.6.1.1.2 Minimum requirement (Category B)	TC3a	TC3a	TC3b	TC4a	TC4b	TC4c
6.6.1.1.3 Additional minimum requirement for BC2 (Category B)	N/A	N/A	N/A	TC4a	TC4b	TC4c
6.6.1.2 Protection of the BS receiver of own or different BS	TC3a	TC3a	TC3b	TC4a	TC4b	TC4c
6.6.1.3 Additional spurious emissions requirements	TC3a	TC3a	TC3b	TC4a	TC4b	TC4c
6.6.1.4 Co-location with other Base Stations	TC3a	TC3a	TC3b	TC4a	TC4b	TC4c
<b>6.6.2 Operating band unwanted emissions</b>	-	-	-	-	-	-
6.6.2.1 General minimum requirement for	TC3a, (TS 25.141) and	N/A	TC3b, (TS 25.142) and	N/A	N/A	N/A

Capability Set	UTRA + E-UTRA (CS 3)			GSM+ UTRA (CS 4)	GSM + E-UTRA (CS 5)	GSM + UTRA + E-UTRA (CS 6)
	BC1	BC2	BC3	BC2	BC2	BC2
Band Categories 1 and 3	(TS 36.141)		(TS 36.141)			
6.6.2.2 General minimum requirement for Band Category 2	N/A	(TS 25.141) and (TS 36.141) TC3a	N/A	(TS 25.141) TC4a TC4d (note1)	(TS 36.141) TC4b TC4e (note1)	(TS 25.141) and (TS 36.141) TC4c TC4e (note1)
6.6.2.3 GSM/EDGE single-RAT requirement	N/A	N/A	N/A	(TS 51.021)	(TS 51.021)	(TS 51.021)
6.6.2.4 Additional requirements	Compliance stated by manufacturer declaration	Compliance stated by manufacturer declaration	Compliance stated by manufacturer declaration	Compliance stated by manufacturer declaration	Compliance stated by manufacturer declaration	Compliance stated by manufacturer declaration
<b>6.6.3 Occupied bandwidth</b>	-	-	-	-	-	-
6.6.3.1 Minimum requirement	(TS 25.141) and (TS 36.141)	(TS 25.141) and (TS 36.141)	(TS 25.142) and (TS 36.141)	(TS 25.141)	(TS 36.141)	(TS 25.141) and (TS 36.141)
<b>6.6.4 Adjacent Channel Leakage power Ratio (ACLR)</b>	-	-	-	-	-	-
6.6.4.1 E- UTRA minimum requirement	(TS 36.141)	(TS 36.141)	(TS 36.141)	N/A	(TS 36.141)	(TS 36.141)
6.6.4.2 UTRA FDD minimum requirement	(TS 25.141)	(TS 25.141)	N/A	(TS 25.141)	N/A	(TS 25.141)
6.6.4.3 UTRA TDD minimum requirement	N/A	N/A	(TS 25.142)	N/A	N/A	N/A
<b>6.7 Transmitter intermodulation</b>	-	-	-	-	-	-
6.7.1 General minimum requirement	Same TC as used in 6.6	Same TC as used in 6.6	Same TC as used in 6.6	Same TC as used in 6.6	Same TC as used in 6.6	Same TC as used in 6.6
6.7.2 Additional minimum requirement (BC2)	N/A	Same TC as used in 6.6	N/A	Same TC as used in 6.6	Same TC as used in 6.6	Same TC as used in 6.6
6.7.3 Additional minimum requirement (BC3)	N/A	N/A	Same TC as used in 6.6	N/A	N/A	N/A
<b>7.2 Reference sensitivity level</b>	-	-	-	-	-	-
7.2.1 E-UTRA minimum requirement	(TS 36.141)	(TS 36.141)	(TS 36.141)	N/A	(TS 36.141)	(TS 36.141)
7.2.2 UTRA FDD minimum requirement	(TS 25.141)	(TS 25.141)	N/A	(TS 25.141)	N/A	(TS 25.141)
7.2.3 UTRA TDD minimum requirement	N/A	N/A	(TS 25.142)	N/A	N/A	N/A
7.2.4 GSM/EDGE minimum requirement	N/A	N/A	N/A	(TS 51.021)	(TS 51.021)	(TS 51.021)
<b>7.3 Dynamic range</b>	-	-	-	-	-	-
7.3.1 E-UTRA minimum	(TS 36.141)	(TS 36.141)	(TS 36.141)	N/A	(TS 36.141)	(TS 36.141)

Capability Set	UTRA + E-UTRA (CS 3)			GSM+ UTRA (CS 4)	GSM + E-UTRA (CS 5)	GSM + UTRA + E-UTRA (CS 6)
	BC1	BC2	BC3	BC2	BC2	BC2
requirement						
7.3.2 UTRA FDD minimum requirement	(TS 25.141)	(TS 25.141)	N/A	(TS 25.141)	N/A	(TS 25.141)
7.3.3 UTRA TDD minimum requirement	N/A	N/A	(TS 25.142)	N/A	N/A	N/A
7.3.4 GSM/EDGE minimum requirement	N/A	N/A	N/A	(TS 51.021)	(TS 51.021)	(TS 51.021)
<b>7.4 In- band selectivity and blocking</b>	-	-	-			-
7.4.1 General blocking minimum requirement	TC3a	TC3a	TC3b	TC5a	TC5b	TC5b
7.4.2 General narrowband blocking minimum requirement	TC3a and TC6b	TC3a and TC6b	TC3b and TC6b	TC5a and TC6a	TC5b and TC6b	TC5b and TC6a
7.4.3 Additional narrowband blocking minimum requirement for GSM/EDGE	N/A	N/A	N/A	(TS 51.021)	(TS 51.021)	(TS 51.021)
7.4.4 GSM/EDGE requirements for AM suppression	N/A	N/A	N/A	(TS 51.021)	(TS 51.021)	(TS 51.021)
7.4.5 Additional BC3 blocking minimum requirement	N/A	N/A	TC3b	N/A	N/A	N/A
<b>7.5 Out-of-band blocking</b>	-	-	-	-	-	-
7.5.1 General minimum requirement	TC3a	TC3a	TC3b	TC5a	TC5b	TC5b
7.5.2 Co-location minimum requirement	TC3a	TC3a	TC3b	TC5a	TC5b	TC5b
<b>7.6 Receiver spurious emissions</b>	-	-	-	-	-	-
7.6.1 General minimum requirement	TC3a	TC3a	TC3b	TC4a	TC4b	TC4c
7.6.2 Additional minimum requirement for BC2 (Category B)	TC3a	TC3a	TC3b	TC4a	TC4b	TC4c
<b>7.7 Receiver intermodulation</b>	-	-	-	-	-	-
7.7.1 General intermodulation minimum requirement	TC3a	TC3a	TC3b	TC5a	TC5b	TC5b
7.7.2 General narrowband intermodulation minimum requirement	TC3a and TC6b	TC3a and TC6b	TC3b and TC6b	TC5a and TC6a	TC5b and TC6b	TC5b and TC6a
7.7.3 Additional	N/A	N/A	N/A	(TS 51.021)	(TS 51.021)	(TS 51.021)

Capability Set	UTRA + E-UTRA (CS 3)			GSM+ UTRA (CS 4)	GSM + E-UTRA (CS 5)	GSM + UTRA + E-UTRA (CS 6)
	BC1	BC2	BC3	BC2	BC2	BC2
narrowband intermodulation minimum requirement for GSM/EDGE						
<b>7.8 In-channel selectivity</b>	-	-	-	-	-	-
7.8.1 E-UTRA minimum requirement	(TS 36.141)	(TS 36.141)	(TS 36.141)	N/A	(TS 36.141)	(TS 36.141)
NOTE 1: The TC shall be used for performing tests when [the declared RF bandwidth for GSM is not equal to the declared RF bandwidth for multi-RAT operations and] the frequency range within the frequency band supported by the BS is a subset of the operating band, or when the maximum supported RF bandwidth covers the entire operating band.						



## 5.2 Single-RAT Multi-carrier capable Base Stations

Table 5.2-1: Test configurations for capability sets for Single-RAT capable BS

Capability Set	UTRA (MC) capable BS (CS1)			E-UTRA (MC) capable BS (CS2)		
BS test case	BC1	BC2	BC3	BC1	BC2	BC3
<b>6.2 Base Station output power</b>	-	-	-	-	-	-
6.2.1 Minimum requirement	TC1a	TC1a	TC1b	TC2	TC2	TC2
6.2.2 Additional requirement (only for band 34)	N/A	N/A	N/A	N/A	N/A	Compliance stated by manufacturer declaration
6.2.3 E-UTRA minimum requirement for DL RS power	N/A	N/A	N/A	(TS 36.141)	(TS 36.141)	(TS 36.141)
6.2.4 UTRA FDD minimum requirement for primary CPICH power	(TS 25.141)	(TS 25.141)	N/A	N/A	N/A	N/A
6.2.5 UTRA TDD minimum requirement for primary CCPCH power	N/A	N/A	(TS 25.142)	N/A	N/A	N/A
<b>6.3 Output power dynamics</b>	-	-	-	-	-	-
6.3.1 E-UTRA minimum requirement	N/A	N/A	N/A	(TS 36.141)	(TS 36.141)	(TS 36.141)
6.3.2 UTRA FDD minimum requirement	(TS 25.141)	(TS 25.141)	N/A	N/A	N/A	N/A
6.3.3 UTRA TDD minimum requirement	N/A	N/A	(TS 25.142)	N/A	N/A	N/A
6.3.4 GSM/EDGE minimum requirement	N/A	N/A	N/A	N/A	N/A	N/A
<b>6.4 Transmit ON/OFF power</b>	-	-	-	-	-	-
6.4.1 Transmitter OFF power	N/A	N/A	TC1b	N/A	N/A	TC2
6.4.2 Transmitter transient period	N/A	N/A	TC1b	N/A	N/A	TC2
<b>6.5 Transmitted signal quality</b>	-	-	-	-	-	-
<b>6.5.1 Modulation quality</b>	-	-	-	-	-	-
6.5.1.1 E-UTRA minimum requirement	N/A	N/A	N/A	TC2	TC2	TC2
6.5.1.2 UTRA FDD minimum requirement	TC1a	TC1a	N/A	N/A	N/A	N/A
6.5.1.3 UTRA	N/A	N/A	TC1b	N/A	N/A	N/A

Capability Set	UTRA (MC) capable BS (CS1)			E-UTRA (MC) capable BS (CS2)		
	BC1	BC2	BC3	BC1	BC2	BC3
<b>BS test case</b>	BC1	BC2	BC3	BC1	BC2	BC3
TDD minimum requirement						
6.5.1.4 GSM/EDGE minimum requirement	N/A	N/A	N/A	N/A	N/A	N/A
<b>6.5.2 Frequency error</b>	-	-	-	-	-	-
6.5.2.1 E-UTRA minimum requirement	N/A	N/A	N/A	Same TC as used in 6.5.1	Same TC as used in 6.5.1	Same TC as used in 6.5.1
6.5.2.2 UTRA FDD minimum requirement	Same TC as used in 6.5.1	Same TC as used in 6.5.1	N/A	N/A	N/A	N/A
6.5.2.3 UTRA TDD minimum requirement	N/A	N/A	Same TC as used in 6.5.1	N/A	N/A	N/A
6.5.2.4 GSM/EDGE minimum requirement	N/A	N/A	N/A	N/A	N/A	N/A
<b>6.5.3 Time alignment between transmitter branches</b>	-	-	-	-	-	-
6.5.3.1 E-UTRA minimum requirement	N/A	N/A	N/A	(TS 36.141)	(TS 36.141)	(TS 36.141)
6.5.3.2 UTRA FDD minimum requirement	(TS 25.141)	(TS 25.141)	N/A	N/A	N/A	N/A
6.5.3.3 UTRA TDD minimum requirement	N/A	N/A	(TS 25.142)	N/A	N/A	N/A
<b>6.6 Unwanted emissions</b>	-	-	-	-	-	-
<b>6.6.1 Transmitter spurious emissions</b>	-	-	-	-	-	-
6.6.1.1.1 Minimum requirement (Category A)	TC1a	TC1a	TC1b	TC2	TC2	TC2
6.6.1.1.2 Minimum requirement (Category B)	TC1a	TC1a	TC1b	TC2	TC2	TC2
6.6.1.1.3 Additional minimum requirement for BC2 (Category B)	N/A	N/A	N/A	N/A	N/A	N/A
6.6.1.2 Protection of the BS receiver of own or different BS	TC1a	TC1a	TC1b	TC2	TC2	TC2
6.6.1.3 Additional spurious emissions	TC1a	TC1a	TC1b	TC2	TC2	TC2

Capability Set	UTRA (MC) capable BS (CS1)			E-UTRA (MC) capable BS (CS2)		
	BC1	BC2	BC3	BC1	BC2	BC3
<b>BS test case requirements</b>						
6.6.1.4 Co-location with other Base Stations	TC1a	TC1a	TC1b	TC2	TC2	TC2
<b>6.6.2 Operating band unwanted emissions</b>	-	-	-	-	-	-
6.6.2.1 General minimum requirement for Band Categories 1 and 3	TC1a and (TS 25.141)	N/A	TC1b and (TS 25.142)	TC2 and (TS 36.141)	N/A	TC2 and (TS 36.141)
6.6.2.2 General minimum requirement for Band Category 2	N/A	TC1a and (TS 25.141)	N/A	N/A	TC2 and (TS 36.141)	N/A
6.6.2.3 GSM/EDGE single-RAT requirements	N/A	N/A	N/A	N/A	N/A	N/A
6.6.2.4 Additional requirements	Compliance stated by manufacturer declaration	Compliance stated by manufacturer declaration	Compliance stated by manufacturer declaration	Compliance stated by manufacturer declaration	Compliance stated by manufacturer declaration	Compliance stated by manufacturer declaration
<b>6.6.3 Occupied bandwidth</b>	-	-	-	-	-	-
6.6.3.1 Minimum requirement	(TS 25.141)	(TS 25.141)	(TS 25.142)	(TS 36.141)	(TS 36.141)	(TS 36.141)
<b>6.6.4 Adjacent Channel Leakage power Ratio (ACLR)</b>		-	-	-	-	-
6.6.4.1 E-UTRA minimum requirement	N/A	N/A	N/A	(TS 36.141)	(TS 36.141)	(TS 36.141)
6.6.4.2 UTRA FDD minimum requirement	(TS 25.141)	(TS 25.141)	N/A	N/A	N/A	N/A
6.6.4.3 UTRA TDD minimum requirement	N/A	N/A	(TS 25.142)	N/A	N/A	N/A
<b>6.7 Transmitter intermodulation</b>	-	-	-	-	-	-
6.7.1 General minimum requirement	Same TC as used in 6.6	Same TC as used in 6.6	Same TC as used in 6.6	Same TC as used in 6.6	Same TC as used in 6.6	Same TC as used in 6.6
6.7.2 Additional minimum requirement (BC2)	N/A	Same TC as used in 6.6	N/A	N/A	Same TC as used in 6.6	N/A
6.7.3 Additional minimum requirement (BC3)	N/A	N/A	Same TC as used in 6.6	N/A	N/A	Same TC as used in 6.6
<b>7.2 Reference sensitivity level</b>	-	-	-	-	-	-
7.2.1 E-UTRA minimum requirement	N/A	N/A	N/A	(TS 36.141)	(TS 36.141)	(TS 36.141)
7.2.2 UTRA FDD minimum	(TS 25.141)	(TS 25.141)	N/A	N/A	N/A	N/A

Capability Set	UTRA (MC) capable BS (CS1)			E-UTRA (MC) capable BS (CS2)		
	BC1	BC2	BC3	BC1	BC2	BC3
<b>BS test case</b>	BC1	BC2	BC3	BC1	BC2	BC3
requirement						
7.2.3 UTRA TDD minimum requirement	N/A	N/A	(TS 25.142)	N/A	N/A	N/A
7.2.4 GSM/EDGE minimum requirement	N/A	N/A	N/A	N/A	N/A	N/A
<b>7.3 Dynamic range</b>	-	-	-	-	-	-
7.3.1 E-UTRA minimum requirement	N/A	N/A	N/A	(TS 36.141)	(TS 36.141)	(TS 36.141)
7.3.2 UTRA FDD minimum requirement	(TS 25.141)	(TS 25.141)	N/A	N/A	N/A	N/A
7.3.3 UTRA TDD minimum requirement	N/A	N/A	(TS 25.142)	N/A	N/A	N/A
7.3.4 GSM/EDGE minimum requirement	N/A	N/A	N/A	N/A	N/A	N/A
<b>7.4 In-band selectivity and blocking</b>	-	-	-	-	-	-
7.4.1 General blocking minimum requirement	TC1a	TC1a	TC1b	TC2	TC2	TC2
7.4.2 General narrowband blocking minimum requirement	TC1a and TC6a	TC1a and TC6a	TC1b and TC6c	TC2 and TC6b	TC2 and TC6b	TC2 and TC6b
7.4.3 Additional narrowband blocking minimum requirement for GSM/EDGE	N/A	N/A	N/A	N/A	N/A	N/A
7.4.4 GSM/EDGE requirements for AM suppression	N/A	N/A	N/A	N/A	N/A	N/A
7.4.5 Additional BC3 blocking minimum requirement	N/A	N/A	TC1b	N/A	N/A	TC2
<b>7.5 Out-of-band blocking</b>	-	-	-	-	-	-
7.5.1 General minimum requirement	TC1a	TC1a	TC1b	TC2	TC2	TC2
7.5.2 Co-location minimum requirement	TC1a	TC1a	TC1b	TC2	TC2	TC2
<b>7.6 Receiver spurious emissions</b>						
7.6.1 General minimum requirement	TC1a	TC1a	TC1b	TC2	TC2	TC2

Capability Set	UTRA (MC) capable BS (CS1)			E-UTRA (MC) capable BS (CS2)		
	BC1	BC2	BC3	BC1	BC2	BC3
<b>BS test case</b>	BC1	BC2	BC3	BC1	BC2	BC3
7.6.2 Additional minimum requirement for BC2 (Category B)	N/A	Compliance stated by manufacturer declaration	N/A	N/A	Compliance stated by manufacturer declaration	N/A
<b>7.7 Receiver intermodulation</b>	-	-	-	-	-	-
7.7.1 General intermodulation minimum requirement	TC1a	TC1a	TC1b	TC2	TC2	TC2
7.7.2 General narrowband intermodulation minimum requirement	TC1a and TC6a	TC1a and TC6a	TC1b and TC6c	TC2 and TC6b	TC2 and TC6b	TC2 and TC6b
7.7.3 Additional narrowband intermodulation minimum requirement for GSM/EDGE	N/A	N/A	N/A	N/A	N/A	N/A
<b>7.8 In-channel selectivity</b>	-	-	-	-	-	-
7.8.1 E-UTRA minimum requirement	N/A	N/A	N/A	(TS 36.141)	(TS 36.141)	(TS 36.141)

## 6 Transmitter characteristics

### 6.1 General

General test conditions for transmitter tests are given in clause 4, including interpretation of measurement results and configurations for testing. BS configurations for the tests are defined in subclause 4.10.

### 6.2 Base Station output power

#### 6.2.1 Base Station maximum output power

##### 6.2.1.1 Definition and applicability

Output power of the Base Station is the mean power delivered to a load with resistance equal to the nominal load impedance of the transmitter.

The maximum total output power,  $P_{\max}$ , of the Base Station is the mean power level measured at the antenna connector during the transmitter ON period in a specified reference condition.

The maximum RAT output power,  $P_{\max, \text{RAT}}$ , of the Base Station is the mean power level measured at the antenna connector during the transmitter ON period for a specific RAT in a specified reference condition.

The maximum carrier output power,  $P_{\max, c}$  of the Base Station is the mean power level measured at the antenna connector during the transmitter ON period for a specific carrier in a specified reference condition.

In certain regions, the minimum requirement for normal conditions may apply also for some conditions outside the ranges defined for the Normal test environment in Annex B.

### 6.2.1.2 Minimum requirement

The minimum requirement is in TS 37.104 [2] subclause 6.2.1.

### 6.2.1.3 Test purpose

The test purpose is to verify the accuracy of the maximum carrier output power across the frequency range and under normal and extreme conditions for all transmitters in the BS.

### 6.2.1.4 Method of test

#### 6.2.1.4.1 Initial conditions

Test environment: normal; see Annex B.2.

RF bandwidth position to be tested:  $B_{\text{RFBW}}$ ,  $M_{\text{RFBW}}$  and  $T_{\text{RFBW}}$ ; see subclause 4.9.1.

In addition, on one ARFCN, UARFCN or E-ARFCN only, the BS output power test shall be performed under extreme power supply as defined in Annex B.3.

NOTE: Tests under extreme power supply also test extreme temperature.

Connect the power measuring equipment to the MSR Base Station antenna connector as shown in Annex D.1.1.

#### 6.2.1.4.2 Procedure

- 1) Set the Base Station to transmit at maximum power according to the applicable test configuration in clause 5 using the corresponding test models or set of physical channels in subclause 4.9.2.
- 2) Measure the mean power for each carrier at the Base Station antenna connector.

### 6.2.1.5 Test requirements

In normal conditions, the measurement result in step 2 of subclause 6.2.1.4.2 shall for UTRA and E-UTRA remain within +2.7 dB and -2.7 dB of the manufacturer's rated carrier output power and for GSM/EDGE remain within +3.0 dB and -3.0 dB of the manufacturer's rated carrier output power.

In extreme conditions, measurement result in step 2 of subclause 6.2.1.4.2 shall for UTRA and E-UTRA remain within +3.2 dB and -3.2 dB of the manufacturer's rated carrier output power and for GSM/EDGE remain within +3.5 dB and -3.5 dB of the manufacturer's rated carrier output power.

## 6.2.2 E-UTRA DL RS power

### 6.2.2.1 Definition and applicability

E-UTRA DL RS power is the resource element power of Downlink Reference Symbol.

The absolute DL RS power is indicated on the DL-SCH. The absolute accuracy is defined as the maximum deviation between the DL RS power indicated on the DL-SCH and the DL RS power at the BS antenna connector.

### 6.2.2.2 Minimum requirement

The minimum requirement is in TS 37.104 [2] subclause 6.2.3.

### 6.2.2.3 Test purpose

The test purpose is to verify that the E-UTRA DL RS power is within the limits specified by the minimum requirement.

#### 6.2.2.4 Method of test

For this requirement Tables 5.1-1 and 5.1-2 refer to single-RAT specifications; see clause 5. The following shall apply:

- For references to TS 36.141 [9], the method of test is specified in TS 36.141 [9], subclause 6.5.4.4

#### 6.2.2.5 Test requirements

The test requirement for DL RS power is specified in TS 36.141 [9], subclause 6.5.4.5.

### 6.2.3 UTRA FDD primary CPICH power

#### 6.2.3.1 Definition and applicability

UTRA FDD primary CPICH power is the code domain power of the Common Pilot Channel. Primary CPICH power is indicated on the BCH. CPICH power accuracy is defined as the maximum deviation between the Primary CPICH code domain power indicated on the BCH and the Primary CPICH code domain power measured at the TX antenna interface.

#### 6.2.3.2 Minimum requirement

The minimum requirement is in TS 37.104 [2] subclause 6.2.4.

#### 6.2.3.3 Test purpose

The test purpose is to verify that the UTRA FDD primary CPICH power is within the limits specified by the minimum requirement.

#### 6.2.3.4 Method of test

For this requirement Tables 5.1-1 and 5.1-2 refer to single-RAT specifications; see clause 5. The following shall apply:

- For references to TS 25.141 [10], the method of test is specified in TS 25.141 [10], subclause 6.2.2.4.

#### 6.2.3.5 Test requirements

For UTRA FDD the test requirement for CPICH power is specified in TS 25.141 [10], subclause 6.2.2.5.

### 6.2.4 UTRA TDD primary CCPCH

#### 6.2.4.1 Definition and applicability

UTRA TDD primary CCPCH power is the code domain power of the Primary Common Control Physical Channel averaged over the transmit timeslot. Primary CCPCH power is signalled on the BCH.

#### 6.2.4.2 Minimum requirement

The minimum requirement is in TS 37.104 [2] subclause 6.2.5.

#### 6.2.4.3 Test purpose

The test purpose is to verify that the UTRA TDD primary CCPCH power is within the limits specified by the minimum requirement.

#### 6.2.4.4 Method of test

For this requirement Tables 5.1-1 and 5.1-2 refer to single-RAT specifications; see clause 5. The following shall apply:

- For references to TS 25.142, the method of test is specified in TS 25.142 [12], subclause 6.4.5.4.

#### 6.2.4.5 Test requirements

For UTRA TDD, the test requirement for primary CCPCH power is specified in TS 25.142 [12], subclause 6.4.5.5.

### 6.3 Output power dynamics

#### 6.3.1 Definition and applicability

Output power dynamics is defined by the MSR BS transmitter's ability to operate at varying output power levels.

#### 6.3.2 Minimum Requirement

The minimum requirement is in TS 37.104 [2] subclause 6.3.1, 6.3.2, 6.3.3 and 6.3.4.

#### 6.3.3 Test purpose

The test purpose is to verify that the output power dynamics are met as specified by the minimum requirement.

#### 6.3.4 Method of test

For this requirement Tables 5.1-1 and 5.1-2 refer to single-RAT specifications; see clause 5. The following shall apply:

- For references to TS 36.141 [9], the method of test is specified in TS 36.141 [9], subclause 6.3.2.4.
- For references to TS 25.141 [10], the method of test is specified in TS 25.141 [10], subclause 6.4.2.4, 6.4.3.4, 6.4.4.4 and 6.4.5.4.
- For references to TS 25.142 [12], the method of test is specified in TS 25.142 [12], subclause 6.4.2.4, 6.4.3.4, 6.4.4.4, 6.4.5.4 and 6.4.6.4.
- For references to TS 51.021 [11], the method of test is specified in TS 51.021 [11], subclause 6.3 and 6.4.

#### 6.3.5 Test Requirement

For E-UTRA, the test requirement is specified in TS 36.141 [9], subclause 6.3.2.5.

For UTRA FDD, the test requirement is specified in TS 25.141 [10], subclause 6.4.2.5, 6.4.3.5, 6.4.4.5 and 6.4.5.5.

For UTRA TDD, the test requirement is specified in TS 25.142 [12], subclause 6.4.2.5, 6.4.3.5, 6.4.4.5, 6.4.5.5 and 6.4.6.5.

For GSM/EDGE, the test requirement is specified in TS 51.021 [11], subclause 6.3.3 and 6.4.3.

### 6.4 Transmit ON/OFF power

The requirements in subclause 6.4 are only applied for BC3 BS.

The requirements in subclause 6.4 are only applied for BC3 BS.

#### 6.4.1 Definition and applicability

Transmitter OFF power is defined as the mean power measured over 70  $\mu$ s filtered with a square filter of bandwidth equal to the RF bandwidth of the BS centred on the central frequency of the RF bandwidth during the transmitter OFF period.

The transmitter transient period is the time period during which the transmitter is changing from the OFF period to the ON period or vice versa. The transmitter transient period is illustrated in Figure 6.4.1-1.



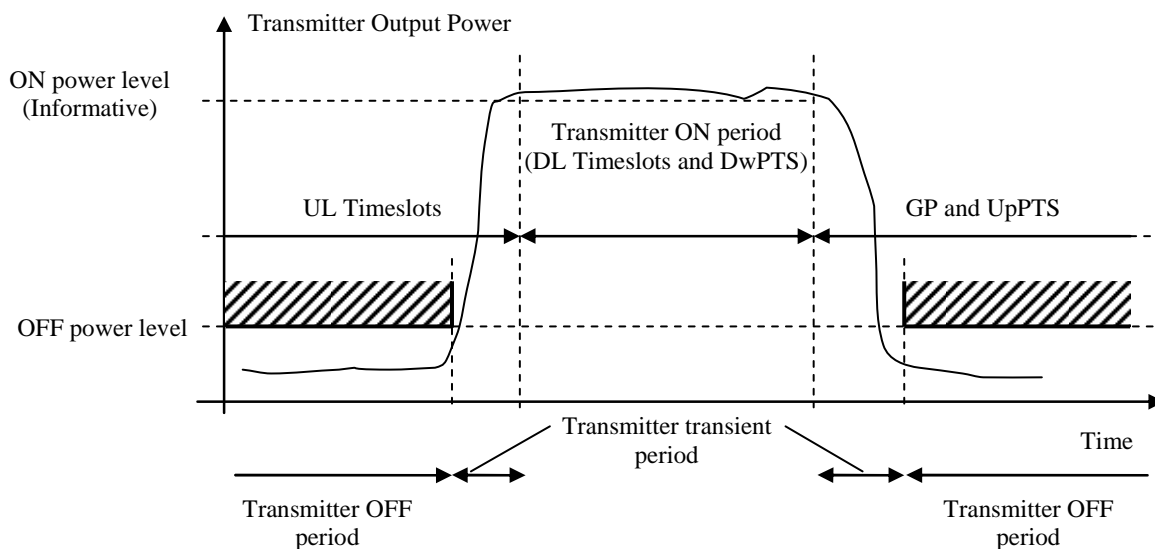

**Figure 6.4.1-1 Illustration of the relations of transmitter ON period, transmitter OFF period and transmitter transient period.**

## 6.4.2 Minimum Requirement

The minimum requirement is in TS 37.104 [2] subclause 6.4.1.1 and subclause 6.4.2.1.

## 6.4.3 Test purpose

The purpose of this test is to verify the BC3 BS transmitter OFF power and transient periods are within the limits of the minimum requirements.

## 6.4.4 Method of test

### 6.4.4.1 Initial conditions

Test environment: normal; see Annex B.2.

RF bandwidth position to be tested:  $M_{\text{RFBW}}$ ; see subclause 4.9.1.

Connect the signal analyzer to the MSR BS antenna connector as shown in Annex D.1.1.

### 6.4.4.2 Procedure

- 1) Set the BS to transmit a signal according to the applicable test configuration in clause 5 using the corresponding test models or set of physical channels in subclause 4.9.2.
- 2) Measure the mean power spectral density measured over  $70\mu\text{s}$  filtered with a square filter of bandwidth equal to the RF bandwidth of the BS centred on the central frequency of the RF bandwidth.  $70\mu\text{s}$  average window centre is set from  $35\mu\text{s}$  after end of one transmitter ON period +  $17\mu\text{s}$  to  $35\mu\text{s}$  before start of next transmitter ON period –  $6.25\mu\text{s}$ .

## 6.4.5 Test requirement

The transmitter OFF power spectral density shall be less than  $-85\text{dBm/MHz} + [\text{TT}]$ .

The measured mean power spectral density according to subclause 6.4.4.2 shall be less than  $-85\text{dBm/MHz} + [\text{TT}]$ .

NOTE: If the above Test Requirement differs from the Minimum Requirement then the Test Tolerance applied for this test is non-zero. The Test Tolerance for this test and the explanation of how the Minimum Requirement has been relaxed by the Test Tolerance are given in Annex C.

## 6.5 Transmitted signal quality

### 6.5.1 Modulation quality

#### 6.5.1.1 Definition and applicability

Modulation quality is defined by the difference between the measured carrier signal and a reference signal. Modulation quality can e.g. be expressed as Error Vector Magnitude (EVM), Peak Code domain Error (PCDE) or Relative Code domain Error (RCDE).

#### 6.5.1.2 Minimum Requirement

The minimum requirement is in TS 37.104 [2] subclause 6.5.1.

#### 6.5.1.3 Test purpose

The test purpose is to verify that modulation quality is within the limit specified by the minimum requirement.

#### 6.5.1.4 Method of test

##### 6.5.1.4.1 Initial conditions

Test environment: normal; see Annex B.2.

RF channels to be tested:  $B_{\text{RFBW}}$ ,  $M_{\text{RFBW}}$  and  $T_{\text{RFBW}}$ ; see subclause 4.9.1.

- 1) Connect measurement device to the base station RF output port as shown in Annex D.1.1.

##### 6.5.1.4.2 Procedure

- 1) Set the BS to transmit according to the applicable test configuration in clause 5 using the corresponding test models or set of physical channels in subclause 4.9.2.
- 2) Perform the measurement on each carrier as follows:
  - For measurement on a E-UTRA carrier, see TS 36.141 [9] subclause 6.5.2.4.2 step 2 to 4.
  - For EVM measurement on a UTRA FDD carrier, see TS 25.141 [10] subclause 6.7.1.4.2 step 2 to 5 using a filter defined in subclause 6.7.1.1.
  - For PCDE measurement on a UTRA FDD carrier, see TS 25.141 [10] subclause 6.7.2.4.2 using TM3.
  - For RCDE measurement on a UTRA FDD carrier, see TS 25.141 [10] subclause 6.7.4.4.2 using TM6.
  - For EVM measurement on a UTRA TDD carrier, see TS 25.142 [12] subclause 6.8.1.4.2.2 using a filter defined in subclause 6.8.1.1.
  - For PCDE measurement on a UTRA TDD carrier, see TS 25.142 [12] subclause 6.8.2.4.1.2.
  - For RCDE measurement on a UTRA TDD carrier, see TS 25.142 [12] subclause 6.8.3.4.1.1.
  - For measurement on a GSM/EDGE carrier, see TS 51.021 [11] subclause 6.2.2.

## 6.5.1.5 Test Requirements

### 6.5.1.5.1 E-UTRA test requirement

For every measured E-UTRA carrier, the test requirement is specified in TS 36.141 [9] subclause 6.5.2.5.

### 6.5.1.5.2 UTRA FDD test requirement

For every measured UTRA FDD carrier, the test requirement is specified in TS 25.141 [10] subclause 6.7.1.5, 6.7.2.5 and 6.7.4.5.

### 6.5.1.5.3 UTRA TDD test requirement

For every measured UTRA TDD carrier, the test requirement is specified in TS 25.142 [12] subclause 6.8.1.5, 6.8.2.5 and 6.8.3.5.

### 6.5.1.5.4 GSM/EDGE test requirement

For every measured GSM/EDGE carrier, the test requirement is specified in TS 51.021 [11] subclause 6.2.3.

## 6.5.2 Frequency error

### 6.5.2.1 Definition and applicability

Frequency error is the measure of the difference between the actual BS transmit frequency and the assigned frequency. The same source shall be used for RF frequency and data clock generation.

It is not possible to verify by testing that the data clock is derived from the same frequency source as used for RF generation. This may be confirmed by the manufacturer's declaration.

### 6.5.2.2 Minimum Requirement

The minimum requirement is in TS 37.104 [2] subclause 6.5.2.

### 6.5.2.3 Test purpose

The test purpose is to verify that frequency error is within the limit specified by the minimum requirement.

### 6.5.2.4 Method of test

Requirement is tested together with Error Vector Magnitude test, as described in subclause 6.5.1.

## 6.5.2.5 Test Requirements

### 6.5.2.5.1 E-UTRA test requirement

For every measured E-UTRA carrier, the test requirement is specified in TS 36.141 [9] subclause 6.5.1.5.

### 6.5.2.5.2 UTRA FDD test requirement

For every measured UTRA FDD carrier, the test requirement is specified in TS 25.141 [10] subclause 6.3.5.

### 6.5.2.5.3 UTRA TDD test requirement

For every measured UTRA TDD carrier, the test requirement is specified in TS 25.142 [12] subclause 6.3.5.

#### 6.5.2.5.4 GSM/EDGE test requirement

For every measured GSM/EDGE carrier, the test requirement is specified in TS 51.021 [11] subclause 6.2.3.

### 6.5.3 Time alignment between transmitter branches

#### 6.5.3.1 Definition and applicability

In Tx Diversity, spatial multiplexing and MIMO, signals are transmitted from two or more antennas. These signals shall be aligned. The time alignment error for transmission is specified as the delay between the signals from two antennas at the antenna ports.

For dual cell transmissions (DC-HSDPA and DB-DC-HSDPA) in UTRA FDD, the time alignment error is defined as the delay between the signals from the two cells at the antenna ports.

This test is only applicable for Node B supporting TX diversity, spatial multiplexing, MIMO, DC-HSDPA or DB-DC-HSDPA and their combinations.

#### 6.5.3.2 Minimum requirement

The minimum requirement is in TS 37.104 [2] subclause 6.5.3.

#### 6.5.3.3 Test purpose

To verify that the timing alignment error in TX diversity, spatial multiplexing, MIMO and DC-HSDPA is within the limit specified by the minimum requirement.

#### 6.5.3.4 Method of test

For this requirement Tables 5.1-1 and 5.1-2 refer to single-RAT specifications; see clause 5. The following shall apply:

- For references to TS 25.141 [10], the method of test is specified in TS 25.141 [10], subclause 6.5.3.4.
- For references to TS 25.142 [12], the method of test is specified in TS 25.142 [12], subclause 6.7.3.4.
- For references to TS 36.141 [9], the method of test is specified in TS 36.141 [9], subclause 6.8.4.4.

#### 6.5.3.5 Test requirement

For E-UTRA, the test requirement for time alignment error is specified in TS 36.141 [9], subclause 6.5.3.5.

For UTRA FDD, the test requirement for time alignment error is specified in TS 25.141 [10], subclause 6.7.3.5.

For UTRA TDD, the test requirement for time alignment error is specified in TS 25.142 [12], subclause 6.8.4.5.

## 6.6 Unwanted emissions

Unwanted emissions consist of out-of-band emissions and spurious emissions [7]. Out of band emissions are unwanted emissions immediately outside the channel bandwidth resulting from the modulation process and non-linearity in the transmitter but excluding spurious emissions. Spurious emissions are emissions which are caused by unwanted transmitter effects such as harmonics emission, parasitic emission, intermodulation products and frequency conversion products, but exclude out of band emissions.

The out-of-band emissions requirement for the BS transmitter is specified in terms of an Operating band unwanted emissions requirement that defines limits for emissions in the downlink operating band plus the frequency ranges 10 MHz above and 10 MHz below the band. Emissions outside of this frequency range are limited by a spurious emissions requirement.

There is in addition a requirement for occupied bandwidth and an ACLR requirement applicable for some RATs.

## 6.6.1 Transmitter spurious emissions

### 6.6.1.1 Definition and applicability

The transmitter spurious emission limits apply from 9 kHz to 12.75 GHz, excluding the frequency range from 10 MHz below the lowest frequency of the downlink operating band up to 10 MHz above the highest frequency of the downlink operating band. Exceptions are the requirement in Table 6.6.1.3.1-2 in TS 37.104 [2] that apply also closer than 10 MHz from the downlink operating band.

The requirements shall apply whatever the type of transmitter considered (single carrier or multi-carrier). It applies for all transmission modes foreseen by the manufacturer's specification. Unless otherwise stated, all requirements are measured as mean power (RMS).

### 6.6.1.2 Minimum requirement

The minimum requirement is in TS 37.104 [2] subclause 6.6.1.

### 6.6.1.3 Test purpose

This test measures conducted spurious emission from the MSR BS transmitter antenna connector, while the transmitter is in operation.

### 6.6.1.4 Method of test

#### 6.6.1.4.1 Initial conditions

Test environment: normal; see Annex B.2.

RF bandwidth position to be tested:  $B_{\text{RFBW}}$ ,  $M_{\text{RFBW}}$  and  $T_{\text{RFBW}}$ ; see subclause 4.9.1.

- 1) Connect the BS antenna connector to a measurement receiver according to Annex D.1.1 using an attenuator or a directional coupler if necessary
- 2) Measurements shall use a measurement bandwidth in accordance to the conditions in TS 37.104 [2] subclause 6.6.1.
- 3) Detection mode: True RMS.
- 4) Configure the BS with transmitters active at their maximum total output power.

#### 6.6.1.4.2 Procedure

- 1) Set the Base Station to transmit at maximum power according to the applicable test configuration in clause 5 using the corresponding test models or set of physical channels in subclause 4.9.2.
- 2) Measure the emission at the specified frequencies with specified measurement bandwidth and note that the measured value does not exceed the specified value.

### 6.6.1.5 Test requirements

The measurement result in step 2 of 6.6.1.4.2 shall not exceed the maximum level specified in Table 6.6.1.5.1-1 to Table 6.6.1.5.6-1 if applicable for the BS under test.

The test requirements of either subclause 6.6.1.5.1 (Category A limits) or subclause 6.6.1.5.2 (Category B limits) shall apply. In addition for a BS operating in Band Category 2, the test requirements of 6.6.1.5.3 shall apply in case of Category B limits.

## 6.6.1.5.1 Spurious emissions (Category A)

The power of any spurious emission shall not exceed the limits in Table 6.6.1.5.1-1

**Table 6.6.1.5.1-1: BS Spurious emission limits, Category A**

Frequency range	Maximum level	Measurement Bandwidth	Note
9kHz - 150kHz	-13 dBm	1 kHz	Note 1
150kHz - 30MHz		10 kHz	Note 1
30MHz - 1GHz		100 kHz	Note 1
1GHz - 12.75 GHz		1 MHz	Note 2
NOTE 1: Bandwidth as in ITU-R SM.329 [13], s4.1			
NOTE 2: Bandwidth as in ITU-R SM.329 [13], s4.1. Upper frequency as in ITU-R SM.329 [13], s2.5 table 1			

## 6.6.1.5.2 Spurious emissions (Category B)

The power of any spurious emission shall not exceed the limits in Table 6.6.1.5.2-1

**Table 6.6.1.5.2-1: BS Spurious emissions limits, Category B**

Frequency range	Maximum Level	Measurement Bandwidth	Note
9 kHz ↔ 150 kHz	-36 dBm	1 kHz	Note 1
150 kHz ↔ 30 MHz	-36 dBm	10 kHz	Note 1
30 MHz ↔ 1 GHz	-36 dBm	100 kHz	Note 1
1 GHz ↔ 12.75 GHz	-30 dBm	1 MHz	Note 2
NOTE 1: Bandwidth as in ITU-R SM.329 [13], s4.1			
NOTE 2: Bandwidth as in ITU-R SM.329 [13], s4.1. Upper frequency as in ITU-R SM.329 [13], s2.5 table 1			

## 6.6.1.5.3 Additional test requirement for BC2 (category B)

For a BS operating in Band Category 2 when GSM/EDGE is configured, the power of any spurious emission shall not exceed the limits in Table 6.6.1.5.3-1.

**Table 6.6.1.5.3-1: Additional BS Spurious emissions limits for BC2, Category B**

Frequency range	Frequency offset from transmitter operating band edge	Maximum Level	Measurement Bandwidth
30 MHz ↔ 1 GHz	10 – 20 MHz	-36 dBm	300 kHz
	20 – 30 MHz	-36 dBm	1 MHz
	≥ 30 MHz	-36 dBm	3 MHz
1 GHz ↔ 12.75 GHz	≥ 30 MHz	-30 dBm	3 MHz

## 6.6.1.5.4 Protection of the BS receiver of own or different BS

This requirement shall be applied for FDD operation in order to prevent the receivers of Base Stations being desensitised by emissions from the BS transmitter. It is measured at the transmit antenna port for any type of BS which has common or separate Tx/Rx antenna ports.

The power of any spurious emission shall not exceed the limits in Table 6.6.1.5.4-1.

**Table 6.6.1.5.4-1: BS Spurious emissions limits for protection of the BS receiver**

Band category	Frequency range	Maximum Level	Measurement Bandwidth	Note
BC1	$F_{UL\_low} - F_{UL\_high}$	-96 dBm	100 kHz	
BC2	$F_{UL\_low} - F_{UL\_high}$	-98 dBm	100 kHz	

#### 6.6.1.5.5 Additional spurious emission requirements

These requirements may be applied for the protection of system operating in frequency ranges other than the BS downlink operating band. The limits may apply as an optional protection of such systems that are deployed in the same geographical area as the BS, or they may be set by local or regional regulation as a mandatory requirement for an operating band. It is in some cases not stated in the present document whether a requirement is mandatory or under what exact circumstances that a limit applies, since this is set by local or regional regulation. An overview of regional requirements in the present document is given in subclause 4.4.

Some requirements may apply for the protection of specific equipment (UE, MS and/or BS) or equipment operating in specific systems (GSM/EDGE, CDMA, UTRA, E-UTRA, etc.) as listed below. The power of any spurious emission shall not exceed the limits of Table 6.6.1.5.5-1 for a BS where requirements for co-existence with the system listed in the first column apply.

**Table 6.6.1.5.5-1: BS Spurious emissions limits for co-existence with systems operating in other frequency bands**

System type to co-exist with	Frequency range for co-existence requirement	Maximum Level	Measurement Bandwidth	Note
GSM900	921 - 960 MHz	-57 dBm	100 kHz	This requirement does not apply to BS operating in band 8
	876 - 915 MHz	-61 dBm	100 kHz	For the frequency range 880-915 MHz, this requirement does not apply to BS operating in band 8, since it is already covered by the requirement in sub-clause 6.6.1.5.4.
DCS1800 (Note 3)	1805 - 1880 MHz	-47 dBm	100 kHz	This requirement does not apply to BS operating in band 3.
	1710 - 1785 MHz	-61 dBm	100 kHz	This requirement does not apply to BS operating in band 3, since it is already covered by the requirement in sub-clause 6.6.1.5.4.
PCS1900	1930 - 1990 MHz	-47 dBm	100 kHz	This requirement does not apply to BS operating in band 2 or band 36.
	1850 - 1910 MHz	-61 dBm	100 kHz	This requirement does not apply to BS operating in band 2, since it is already covered by the requirement in sub-clause 6.6.1.5.4. This requirement does not apply to BS operating in band 35.
GSM850 or CDMA850	869 - 894 MHz	-57 dBm	100 kHz	This requirement does not apply to BS operating in band 5
	824 - 849 MHz	-61 dBm	100 kHz	This requirement does not apply to BS operating in band 5, since it is already covered by the requirement in sub-clause 6.6.1.5.4.
UTRA FDD Band I or E-UTRA Band 1	2110 - 2170 MHz	-52 dBm	1 MHz	This requirement does not apply to BS operating in band 1,
	1920 - 1980 MHz	-49 dBm	1 MHz	This requirement does not apply to BS operating in band 1, since it is already covered by the requirement in sub-clause 6.6.1.5.4.
UTRA FDD Band II or E-UTRA Band 2	1930 - 1990 MHz	-52 dBm	1 MHz	This requirement does not apply to BS operating in band 2.
	1850 - 1910 MHz	-49 dBm	1 MHz	This requirement does not apply to BS operating in band 2, since it is already covered by the requirement in sub-clause 6.6.1.5.4
UTRA FDD Band III or E-UTRA Band 3 (Note 3)	1805 - 1880 MHz	-52 dBm	1 MHz	This requirement does not apply to BS operating in band 3.
	1710 - 1785 MHz	-49 dBm	1 MHz	This requirement does not apply to BS operating in band 3, since it is already covered by the requirement in sub-clause 6.6.1.5.4.
UTRA FDD Band IV or E-UTRA Band 4	2110 - 2155 MHz	-52 dBm	1 MHz	This requirement does not apply to BS operating in band 4 or 10.
	1710 - 1755 MHz	-49 dBm	1 MHz	This requirement does not apply to BS operating in band 4 or 10, since it is already covered by the requirement in sub-clause 6.6.1.5.4.
UTRA FDD Band V or E-UTRA Band 5	869 - 894 MHz	-52 dBm	1 MHz	This requirement does not apply to BS operating in band 5
	824 - 849 MHz	-49 dBm	1 MHz	This requirement does not apply to BS operating in band 5, since it is already covered by the requirement in sub-clause 6.6.1.5.4.
UTRA FDD Band VI, XIX or E-UTRA Band 6, 18, 19	860 - 895 MHz	-52 dBm	1 MHz	This requirement does not apply to BS operating in band 6, 18, 19
	815 - 830 MHz	-49 dBm	1 MHz	This requirement does not apply to BS operating in band 18 since it is already covered by the requirement in sub-clause 6.6.1.5.4.
	830 - 850 MHz	-49 dBm	1 MHz	This requirement does not apply to E-UTRA BS operating in band 6, 19, since it is already covered by the requirement in sub-clause 6.6.1.5.4.
UTRA FDD Band VII or E-UTRA Band 7	2620 - 2690 MHz	-52 dBm	1 MHz	This requirement does not apply to BS operating in band 7.
	2500 - 2570 MHz	-49 dBm	1 MHz	This requirement does not apply to BS operating in band 7, since it is already covered by the requirement in sub-clause 6.6.1.5.4.
UTRA FDD Band VIII or	925 - 960 MHz	-52 dBm	1 MHz	This requirement does not apply to BS operating in band 8.



E-UTRA Band 8	880 - 915 MHz	-49 dBm	1 MHz	This requirement does not apply to BS operating in band 8, since it is already covered by the requirement in sub-clause 6.6.1.5.4.
UTRA FDD Band IX or E-UTRA Band 9	1844.9 - 1879.9 MHz	-52 dBm	1 MHz	This requirement does not apply to BS operating in band 9.
	1749.9 - 1784.9 MHz	-49 dBm	1 MHz	This requirement does not apply to BS operating in band 9, since it is already covered by the requirement in sub-clause 6.6.1.5.4.
UTRA FDD Band X or E-UTRA Band 10	2110 - 2170 MHz	-52 dBm	1 MHz	This requirement does not apply to BS operating in band 4 or 10.
	1710 - 1770 MHz	-49 dBm	1 MHz	This requirement does not apply to BS operating in band 10, since it is already covered by the requirement in sub-clause 6.6.1.5.4. For BS operating in band 4, it applies for 1755 MHz to 1770 MHz, while the rest is covered in sub-clause 6.6.1.5.4.
UTRA FDD Band XI or XXI or E-UTRA Band 11 or 21	1475.9 - 1510.9 MHz	-52 dBm	1 MHz	This requirement does not apply to BS operating in band 11 or 21.
	1427.9 - 1447.9 MHz	-49 dBm	1 MHz	This requirement does not apply to BS operating in band 11, since it is already covered by the requirement in sub-clause 6.6.1.5.4.
	1447.9 - 1462.9 MHz	-49 dBm	1 MHz	This requirement does not apply to E-UTRA BS operating in band 21, since it is already covered by the requirement in sub-clause 6.6.1.5.4.
UTRA FDD Band XII or E-UTRA Band 12	728 - 746 MHz	-52 dBm	1 MHz	This requirement does not apply to BS operating in band 12.
	698 - 716 MHz	-49 dBm	1 MHz	This requirement does not apply to BS operating in band 12, since it is already covered by the requirement in sub-clause 6.6.1.5.4.
UTRA FDD Band XIII or E-UTRA Band 13	746 - 756 MHz	-52 dBm	1 MHz	This requirement does not apply to BS operating in band 13.
	777 - 787 MHz	-49 dBm	1 MHz	This requirement does not apply to BS operating in band 13, since it is already covered by the requirement in sub-clause 6.6.1.5.4.
UTRA FDD Band XIV or E-UTRA Band 14	758 - 768 MHz	-52 dBm	1 MHz	This requirement does not apply to BS operating in band 14.
	788 - 798 MHz	-49 dBm	1 MHz	This requirement does not apply to BS operating in band 14, since it is already covered by the requirement in sub-clause 6.6.1.5.4.
E-UTRA Band 17	734 - 746 MHz	-52 dBm	1 MHz	This requirement does not apply to BS operating in band 17.
	704 - 716 MHz	-49 dBm	1 MHz	This requirement does not apply to BS operating in band 17, since it is already covered by the requirement in subclause 6.6.1.5.4.
UTRA FDD Band XX or E-UTRA Band 20	791 - 821 MHz	-52 dBm	1 MHz	This requirement does not apply to BS operating in band 20.
	832 - 862 MHz	-49 dBm	1 MHz	This requirement does not apply to BS operating in band 20, since it is already covered by the requirement in subclause 6.6.1.5.4.
UTRA TDD in Band a) or E-UTRA Band 33	1900 - 1920 MHz	-52 dBm	1 MHz	This requirement does not apply to BS operating in Band 33
UTRA TDD in Band a) or E-UTRA Band 34	2010 - 2025 MHz	-52 dBm	1 MHz	This requirement does not apply to BS operating in Band 34
UTRA TDD in Band b) or E-UTRA Band 35	1850 - 1910 MHz	-52 dBm	1 MHz	This requirement does not apply to BS operating in Band 35
UTRA TDD in Band b) or E-UTRA Band 36	1930 - 1990 MHz	-52 dBm	1 MHz	This requirement does not apply to BS operating in Band 2 and 36
UTRA TDD in Band c) or E-UTRA Band 37	1910 - 1930 MHz	-52 dBm	1 MHz	This is not applicable to BS operating in Band 37. This unpaired band is defined in ITU-R M.1036, but is pending any future deployment.
UTRA TDD in Band d) or E-UTRA Band 38	2570 - 2620 MHz	-52 dBm	1 MHz	This requirement does not apply to BS operating in Band 38.

E-UTRA Band 39	1880 – 1920MHz	-52 dBm	1 MHz	This is not applicable to BS operating in Band 39
E-UTRA Band 40	2300 – 2400MHz	-52 dBm	1 MHz	This is not applicable to BS operating in Band 40

NOTE 1: As defined in the scope for spurious emissions in this subclause, the co-existence requirements in Table 6.6.1.5.5-1 do not apply for the 10 MHz frequency range immediately outside the downlink operating band (see Tables 4.4-1 and 4.4-2). Emission limits for this excluded frequency range may be covered by local or regional requirements.

NOTE 2: The table above assumes that two operating bands, where the frequency ranges in Table 4.4-1 or Table 4.4-2 would be overlapping, are not deployed in the same geographical area. For such a case of operation with overlapping frequency arrangements in the same geographical area, special co-existence requirements may apply that are not covered by the 3GPP specifications.

NOTE 3: For the protection of DCS1800, UTRA Band III or E-UTRA Band 3 in China, the frequency ranges of the downlink and uplink protection requirements are 1805 – 1850 MHz and 1710 – 1755 MHz respectively.

The following requirement may be applied for the protection of PHS. This requirement is also applicable at specified frequencies falling between 10 MHz below the lowest BS transmitter frequency of the downlink operating band and 10 MHz above the highest BS transmitter frequency of the downlink operating band.

The power of any spurious emission shall not exceed:

**Table 6.6.1.5.5-2: BS Spurious emissions limits for BS for co-existence with PHS**

Frequency range	Maximum Level	Measurement Bandwidth	Note
1884.5 - 1919.6 MHz	-41 dBm	300 kHz	Applicable for co-existence with PHS system operating in 1884.5-1919.6MHz.
1884.5 - 1915.7 MHz	-41 dBm	300 kHz	Applicable for co-existence with PHS system operating in 1884.5-1915.7MHz
NOTE: The requirement is not applicable in China.			

In addition to the requirements in subclauses 6.6.1.5.1 to 6.6.1.5.4 and above in the present subclause, the BS may have to comply with the applicable emission limits established by FCC Title 47 [8], when deployed in regions where those limits are applied, and under the conditions declared by the manufacturer.

#### 6.6.1.5.6 Co-location with other Base Stations

These requirements may be applied for the protection of other BS receivers when GSM900, DCS1800, PCS1900, GSM850, CDMA850, UTRA FDD, UTRA TDD and/or E-UTRA BS are co-located with a BS.

The requirements assume a 30 dB coupling loss between transmitter and receiver.

NOTE: For co-location with UTRA, the requirements are based on co-location with Wide Area UTRA FDD or TDD Base Stations.

The power of any spurious emission shall not exceed the limits of Table 6.6.1.5.6-1 for a BS where requirements for co-location with a BS type listed in the first column apply.

**Table 6.6.1.5.6-1: BS Spurious emissions limits for BS co-located with another BS**

Type of co-located BS	Frequency range for co-location requirement	Maximum Level	Measurement Bandwidth	Note
Macro GSM900	876-915 MHz	-98 dBm	100 kHz	
Macro DCS1800	1710 - 1785 MHz	-98 dBm	100 kHz	
Macro PCS1900	1850 - 1910 MHz	-98 dBm	100 kHz	
Macro GSM850 or CDMA850	824 - 849 MHz	-98 dBm	100 kHz	
UTRA FDD Band I or E-UTRA Band 1	1920 - 1980 MHz	-96 dBm	100 kHz	
UTRA FDD Band II or E-UTRA Band 2	1850 - 1910 MHz	-96 dBm	100 kHz	
UTRA FDD Band III or E-UTRA Band 3	1710 - 1785 MHz	-96 dBm	100 kHz	
UTRA FDD Band IV or E-UTRA Band 4	1710 - 1755 MHz	-96 dBm	100 kHz	
UTRA FDD Band V or E-UTRA Band 5	824 - 849 MHz	-96 dBm	100 kHz	
UTRA FDD Band VI, XIX or E-UTRA Band 6, 19	830 - 850 MHz	-96 dBm	100 kHz	
UTRA FDD Band VII or E-UTRA Band 7	2500 - 2570 MHz	-96 dBm	100 KHz	
UTRA FDD Band VIII or E-UTRA Band 8	880 - 915 MHz	-96 dBm	100 KHz	
UTRA FDD Band IX or E-UTRA Band 9	1749.9 - 1784.9 MHz	-96 dBm	100 KHz	
UTRA FDD Band X or E-UTRA Band 10	1710 - 1770 MHz	-96 dBm	100 kHz	
UTRA FDD Band XI or E-UTRA Band 11	1427.9 - 1447.9 MHz	-96 dBm	100 kHz	
UTRA FDD Band XII or E-UTRA Band 12	698 - 716 MHz	-96 dBm	100 kHz	
UTRA FDD Band XIII or E-UTRA Band 13	777 - 787 MHz	-96 dBm	100 kHz	
UTRA FDD Band XIV or E-UTRA Band 14	788 - 798 MHz	-96 dBm	100 kHz	
E-UTRA Band 17	704 - 716 MHz	-96 dBm	100 kHz	
E-UTRA Band 18	815 - 830 MHz	-96 dBm	100 kHz	
UTRA FDD Band XX or E-UTRA Band 20	832 - 862 MHz	-96 dBm	100 kHz	
UTRA FDD Band XXI or E-UTRA Band 21	1447.9 – 1462.9 MHz	-96 dBm	100 kHz	
UTRA TDD in Band a) or E-UTRA Band 33	1900 - 1920 MHz	-96 dBm	100 kHz	This is not applicable to BS operating in Band 33
UTRA TDD in Band a) or E-UTRA Band 34	2010 - 2025 MHz	-96 dBm	100 kHz	This is not applicable to BS operating in Band 34
UTRA TDD in Band b) or E-UTRA Band 35	1850 – 1910 MHz	-96 dBm	100 kHz	This is not applicable to BS operating in Band 35
UTRA TDD in Band b) or E-UTRA Band 36	1930 - 1990 MHz	-96 dBm	100 kHz	This is not applicable to BS operating in Band 2 and 36

UTRA TDD in Band c) or E-UTRA Band 37	1910 - 1930 MHz	-96 dBm	100 kHz	This is not applicable to BS operating in Band 37. This unpaired band is defined in ITU-R M.1036, but is pending any future deployment.
UTRA TDD in Band d) or E-UTRA Band 38	2570 – 2620 MHz	-96 dBm	100 kHz	This is not applicable to BS operating in Band 38.
E-UTRA Band 39	1880 – 1920MHz	-96 dBm	100 kHz	This is not applicable to BS operating in Band 33 and 39
E-UTRA Band 40	2300 – 2400MHz	-96 dBm	100 kHz	This is not applicable to BS operating in Band 40

NOTE 1: As defined in the scope for spurious emissions in this subclause, the co-location requirements in Table 6.6.1.5.6-1 do not apply for the 10 MHz frequency range immediately outside the BS transmit frequency range of a downlink operating band (see Tables 4.4-1 and 4.4-2). The current state-of-the-art technology does not allow a single generic solution for co-location with other system on adjacent frequencies for 30 dB BS-BS minimum coupling loss. However, there are certain site-engineering solutions that can be used. These techniques are addressed in TR 25.942 [14].

NOTE 2: The table above assumes that two operating bands, where the corresponding BS transmit and receive frequency ranges in Table 4.4-1 or Table 4.4-2 would be overlapping, are not deployed in the same geographical area. For such a case of operation with overlapping frequency arrangements in the same geographical area, special co-location requirements may apply that are not covered by the 3GPP specifications.

NOTE 3: Co-located TDD Base Stations that are synchronized and using the same operating band can transmit without special co-locations requirements. For unsynchronized Base Stations, special co-location requirements may apply that are not covered by the 3GPP specifications.

## 6.6.2 Operating band unwanted emissions

### 6.6.2.1 Definition and applicability

The Operating band unwanted emission limits are defined from 10 MHz below the lowest frequency of the downlink operating band to the lower RF bandwidth edge located at  $F_{BW\text{ RF,low}}$  and from the upper RF bandwidth edge located at  $F_{BW\text{ RF,high}}$  up to 10 MHz above the highest frequency of the downlink operating band.

The requirements shall apply whatever the type of transmitter considered (single RAT or multi-RAT, single carrier or multi-carrier) and for all transmission modes foreseen by the manufacturer's specification, except for GSM/EDGE single RAT operation. The requirements in TS 45.005 [6] as defined in subclause 6.6.2.3 apply to an MSR Base Station for GSM/EDGE single RAT operation in Band Category 2.

### 6.6.2.2 Minimum requirement

The minimum requirement is in TS 37.104 [2] subclause 6.6.2.1, 6.6.2.2, 6.6.2.3 and 6.6.2.4.

### 6.6.2.3 Test purpose

This test measures the emissions of the MSR BS, close to the assigned channel bandwidth of the wanted signal, while the transmitter is in operation.

#### 6.6.2.4 Method of test

For some of the test cases Tables 5.1-1 and 5.1-2 refer to single-RAT specifications; see clause 5. In this case the following shall apply:

- For references to TS 25.141 [10], the method of test is specified in TS 25.141 [10], subclause 6.5.2.1.4.
- For references to TS 25.142 [12], the method of test is specified in TS 25.142 [12], subclause 6.6.2.1.4.
- For references to TS 36.141 [9], the method of test is specified in TS 36.141 [9], subclause 6.6.3.4.

NOTE: In this case the test requirements of the present document defined in subclause 6.6.2.5 apply.

For GSM/EDGE single-RAT requirements, the method of test is specified in TS 51.021 [11], applicable parts of subclause 6.5.1, 6.5.2, 6.6.2 and 6.12.

For test requirements of operating band unwanted emissions using the MSR test configurations defined in subclause 4.8, the, method of test described in subclauses 6.6.2.4.1 and 6.6.2.4.2 applies.

##### 6.6.2.4.1 Initial conditions

Test environment: normal; see Annex B.2.

RF bandwidth position to be tested:  $B_{\text{RFBW}}$ ,  $M_{\text{RFBW}}$  and  $T_{\text{RFBW}}$ ; see subclause 4.9.1.

- 1) Connect the signal analyzer to the Base Station RF output port as shown in Annex D.1.1.

As a general rule, the resolution bandwidth of the measuring equipment should be equal to the measurement bandwidth. However, to improve measurement accuracy, sensitivity, efficiency and to avoid e.g. carrier leakage, the resolution bandwidth may be smaller than the measurement bandwidth. When the resolution bandwidth is smaller than the measurement bandwidth, the result should be integrated over the measurement bandwidth in order to obtain the equivalent noise bandwidth of the measurement bandwidth.

- 2) Detection mode: True RMS.

##### 6.6.2.4.2 Procedure

- 1) Set the Base Station to transmit at maximum power according to the applicable test configuration in clause 5 using the corresponding test models or set of physical channels in subclause 4.9.2.
- 2) Step the centre frequency of the measurement filter in contiguous steps and measure the emission within the specified frequency ranges with the specified measurement bandwidth.
- 3) Repeat the test for the remaining test cases with channel set-up according to clause 5 and subclause 4.9.2.

#### 6.6.2.5 Test requirement

##### 6.6.2.5.1 Test requirements for Band Categories 1 and 3

For a BS operating in Band Category 1 or Band Category 3, emissions shall not exceed the maximum levels specified in Table 6.6.2.5.1-1 below, where:

- $\Delta f$  is the separation between the RF bandwidth edge frequency and the nominal -3 dB point of the measuring filter closest to the carrier frequency.
- $f_{\text{offset}}$  is the separation between the RF bandwidth edge frequency and the centre of the measuring filter.
- $f_{\text{offset}_{\text{max}}}$  is the offset to the frequency 10 MHz outside the downlink operating band.
- $\Delta f_{\text{max}}$  is equal to  $f_{\text{offset}_{\text{max}}}$  minus half of the bandwidth of the measuring filter.

**Table 6.6.2.5.1-1: Operating band unwanted emission mask (UEM) for BC1 and BC3**

Frequency offset of measurement filter -3dB point, $\Delta f$	Frequency offset of measurement filter centre frequency, $f_{\text{offset}}$	Minimum requirement	Measurement bandwidth
$0 \text{ MHz} \leq \Delta f < 0.2 \text{ MHz}$	$0.015 \text{ MHz} \leq f_{\text{offset}} < 0.215 \text{ MHz}$	-12.5 dBm	30 kHz
$0.2 \text{ MHz} \leq \Delta f < 1 \text{ MHz}$	$0.215 \text{ MHz} \leq f_{\text{offset}} < 1.015 \text{ MHz}$	$-12.5 \text{ dBm} - 15 \cdot \left( \frac{f_{\text{offset}}}{\text{MHz}} - 0.215 \right) \text{ dB}$	30 kHz
(Note 1)	$1.015 \text{ MHz} \leq f_{\text{offset}} < 1.5 \text{ MHz}$	-24.5 dBm	30 kHz
$1 \text{ MHz} \leq \Delta f \leq \min(\Delta f_{\text{max}}, 10 \text{ MHz})$	$1.5 \text{ MHz} \leq f_{\text{offset}} < \min(f_{\text{offset}_{\text{max}}}, 10.5 \text{ MHz})$	-11.5 dBm	1 MHz
$10 \text{ MHz} \leq \Delta f \leq \Delta f_{\text{max}}$	$10.5 \text{ MHz} \leq f_{\text{offset}} < f_{\text{offset}_{\text{max}}}$	-15 dBm (Note 2)	1 MHz

NOTE 1: This frequency range ensures that the range of values of  $f_{\text{offset}}$  is continuous.

NOTE 2: The requirement is not applicable when  $\Delta f_{\text{max}} < 10 \text{ MHz}$ .

#### 6.6.2.5.2 Test requirements for Band Category 2

For a BS operating in Band Category 2, emissions shall not exceed the maximum levels specified in Table 6.6.2.5.2-1 and 6.6.2.5.2-2 below, where:

- $\Delta f$  is the separation between the RF bandwidth edge frequency and the nominal -3dB point of the measuring filter closest to the carrier frequency.
- $f_{\text{offset}}$  is the separation between the RF bandwidth edge frequency and the centre of the measuring filter.
- $f_{\text{offset}_{\text{max}}}$  is the offset to the frequency 10 MHz outside the downlink operating band.
- $\Delta f_{\text{max}}$  is equal to  $f_{\text{offset}_{\text{max}}}$  minus half of the bandwidth of the measuring filter.

**Table 6.6.2.5.2-1: Operating band unwanted emission mask (UEM) for BC2**

Frequency offset of measurement filter -3dB point, $\Delta f$	Frequency offset of measurement filter centre frequency, $f_{\text{offset}}$	Minimum requirement	Measurement bandwidth
$0 \text{ MHz} \leq \Delta f < 0.2 \text{ MHz}$ (Note 1)	$0.015 \text{ MHz} \leq f_{\text{offset}} < 0.215 \text{ MHz}$	-12.5 dBm	30 kHz
$0.2 \text{ MHz} \leq \Delta f < 1 \text{ MHz}$	$0.215 \text{ MHz} \leq f_{\text{offset}} < 1.015 \text{ MHz}$	$-12.5 \text{ dBm} - 15 \cdot \left( \frac{f_{\text{offset}}}{\text{MHz}} - 0.215 \right) \text{ dB}$	30 kHz
(Note 4)	$1.015 \text{ MHz} \leq f_{\text{offset}} < 1.5 \text{ MHz}$	-24.5 dBm	30 kHz
$1 \text{ MHz} \leq \Delta f \leq \min(\Delta f_{\text{max}}, 10 \text{ MHz})$	$1.5 \text{ MHz} \leq f_{\text{offset}} < \min(f_{\text{offset}_{\text{max}}}, 10.5 \text{ MHz})$	-11.5 dBm	1 MHz
$10 \text{ MHz} \leq \Delta f \leq \Delta f_{\text{max}}$	$10.5 \text{ MHz} \leq f_{\text{offset}} < f_{\text{offset}_{\text{max}}}$	-15 dBm (Note 5)	1 MHz
NOTE 1: For operation with a GSM/EDGE or an E-UTRA 1.4 or 3 MHz carrier adjacent to the RF bandwidth edge, the limits in Table 6.6.2.5-2 apply for $0 \text{ MHz} \leq \Delta f < 0.15 \text{ MHz}$ .			

**Table 6.6.2.5.2-2: Operating band unwanted emission limits for operation in BC2 with GSM/EDGE or E-UTRA 1.4 or 3 MHz carriers adjacent to the RF bandwidth edge**

Frequency offset of measurement filter -3dB point, $\Delta f$	Frequency offset of measurement filter centre frequency, $f_{\text{offset}}$	Minimum requirement	Measurement bandwidth
$0 \text{ MHz} \leq \Delta f < 0.05 \text{ MHz}$	$0.015 \text{ MHz} \leq f_{\text{offset}} < 0.065 \text{ MHz}$	$3.5 \text{ dBm} - 60 \cdot \left( \frac{f_{\text{offset}}}{\text{MHz}} - 0.015 \right) \text{ dB}$	30 kHz
$0.05 \text{ MHz} \leq \Delta f < 0.15 \text{ MHz}$	$0.065 \text{ MHz} \leq f_{\text{offset}} < 0.165 \text{ MHz}$	$0.5 \text{ dBm} - 160 \cdot \left( \frac{f_{\text{offset}}}{\text{MHz}} - 0.065 \right) \text{ dB}$	30 kHz
NOTE 2: The limits in this table only apply for operation with a GSM/EDGE or an E-UTRA 1.4 or 3 MHz carrier adjacent to the RF bandwidth edge.			

NOTE 3: All limits in Table 6.6.2.5.2-1 are identical to the corresponding limits for Band Category 1 and 3.

NOTE 4: This frequency range ensures that the range of values of  $f_{\text{offset}}$  is continuous.

NOTE 5: The requirement is not applicable when  $\Delta f_{\text{max}} < 10 \text{ MHz}$ .

### 6.6.2.5.3 Test requirements for GSM/EDGE single-RAT requirements

The following test requirements and the corresponding test method specified in TS 51.021 [11] apply to an MSR Base Station for GSM/EDGE single RAT operation in Band Category 2:

- Spectrum due to the modulation and wide band noise, applicable parts of subclause 6.5.1.
- Spectrum due to switching transients, applicable parts of subclause 6.5.2.
- Emission requirement for frequency offsets of between 2 and 10 MHz outside relevant transmit band, applicable parts of subclause 6.6.2.
- Intra BTS Intermodulation, applicable parts of subclause 6.12.

### 6.6.2.5.4 Test requirements for additional requirements

#### 6.6.2.5.4.1 Limits in FCC Title 47

In addition to the requirements in subclauses 6.6.2.5.1 and 6.6.2.5.2, the BS may have to comply with the applicable emission limits established by FCC Title 47 [8], when deployed in regions where those limits are applied, and under the conditions declared by the manufacturer.

#### 6.6.2.5.4.2 Unsynchronized operation for BC3

In certain regions, the following requirements may apply to a TDD BS operating in BC3 in the same geographic area and in the same operating band as another TDD system without synchronisation. For this case the emissions shall not exceed -52 dBm/MHz in the downlink operating band except in:

- The frequency range from 10 MHz below the lower RF bandwidth edge to the frequency 10 MHz above the upper RF bandwidth edge.

NOTE 1: Local or regional regulations may specify another excluded frequency range, which may include frequencies where synchronised TDD systems operate.

NOTE 2: TDD Base Stations that are synchronized and operating in BC3 can transmit without these additional co-existence requirements.

#### 6.6.2.5.4.3 Protection of DTT

In certain regions the following requirement may apply for protection of DTT. For a BS operating in Band 20, the level of emissions in the band 470-790 MHz, measured in an 8 MHz filter bandwidth on centre frequencies  $F_{\text{filter}}$  according to Table 6.6.2.5.4.3-1, shall not exceed the maximum emission level  $P_{\text{EM,N}}$  declared by the manufacturer. This requirement applies in the frequency range 470-790 MHz even though part of the range falls in the spurious domain.

**Table 6.6.2.5.4.3-1: Declared emissions levels for protection of DTT**

Filter centre frequency, $F_{\text{filter}}$	Measurement bandwidth	Declared emission level [dBm]
$F_{\text{filter}} = 8 \cdot N + 306$ (MHz); $21 \leq N \leq 60$	8 MHz	$P_{\text{EM,N}}$

NOTE: The regional requirement is defined in terms of EIRP (effective isotropic radiated power), which is dependent on both the BS emissions at the antenna connector and the deployment (including antenna gain and feeder loss). The requirement defined above provides the characteristics of the Base Station needed to verify compliance with the regional requirement. Compliance with the regional requirement can be determined using the method outlined in Annex G of TS 36.104 [5].

#### 6.6.2.5.4.4 Co-existence with services in adjacent frequency bands

This requirement may be applied for the protection of systems operating in frequency bands adjacent to Band 1 as defined in subclause 4.5, in geographic areas in which both an adjacent band service and UTRA and/or E-UTRA are deployed.

The power of any spurious emission shall not exceed:

**Table 6.6.2.5.4.4-1: Emissions limits for protection of adjacent band services**

Operating Band	Frequency range	Maximum Level	Measurement Bandwidth
1	2100-2105 MHz	$-30 + 3.4 \cdot (f - 2100 \text{ MHz})$ dBm	1 MHz
	2175-2180 MHz	$-30 + 3.4 \cdot (2180 \text{ MHz} - f)$ dBm	1 MHz

### 6.6.3 Occupied bandwidth

#### 6.6.3.1 Definition and applicability

The occupied bandwidth is the width of a frequency band such that, below the lower and above the upper frequency limits, the mean powers emitted are each equal to a specified percentage  $\beta/2$  of the total mean transmitted power. See also ITU-R Recommendation SM.328 [15].

The value of  $\beta/2$  shall be taken as 0.5%.

#### 6.6.3.2 Minimum requirements

The minimum requirement is in TS 37.104 [2] subclause 6.6.3.

#### 6.6.3.3 Test purpose

The occupied bandwidth, defined in the Radio Regulations of the International Telecommunication Union ITU, is a useful concept for specifying the spectral properties of a given emission in the simplest possible manner; see also ITU-R Recommendation SM.328 [15]. The test purpose is to verify that the emission of the BS does not occupy an excessive bandwidth for the service to be provided and is, therefore, not likely to create interference to other users of the spectrum beyond undue limits.



### 6.6.3.4 Method of test

For this requirement Tables 5.1-1 and 5.1-2 refer to single-RAT specifications; see clause 5. The following shall apply:

- For references to TS 25.141 [10], the method of test is specified in TS 25.141 [10], subclause 6.5.1.4.
- For references to TS 25.142 [12], the method of test is specified in TS 25.142 [12], subclause 6.6.1.4.
- For references to TS 36.141 [9], the method of test is specified in TS 36.141 [9], subclause 6.6.1.4.

### 6.6.3.5 Test requirement

The occupied bandwidth shall be less than the values listed in Table 6.6.3.5-1.

**Table 6.6.3.5-1: Occupied bandwidth**

RAT	Occupied bandwidth limit
E-UTRA	$BW_{\text{Channel}}$
UTRA FDD	5 MHz
1.28 Mcps UTRA TDD	1.6 MHz

## 6.6.4 Adjacent Channel Leakage power Ratio (ACLR)

### 6.6.4.1 Definition and applicability

Adjacent Channel Leakage power Ratio (ACLR) is the ratio of the filtered mean power centred on the assigned channel frequency to the filtered mean power centred on an adjacent channel frequency. The requirement applies to frequency ranges outside the Base Station RF bandwidth.

### 6.6.4.2 Minimum requirement

The minimum requirement is in TS 37.104 [2] subclause 6.6.4.

### 6.6.4.3 Test purpose

To verify that the adjacent channel leakage power ratio requirement shall be met as specified by the minimum requirement.

### 6.6.4.4 Method of test

For this requirement Tables 5.1-1 and 5.1-2 refer to single-RAT specifications; see clause 5. The following shall apply:

- For references to TS 25.141 [10], the method of test is specified in TS 25.141 [10], subclause 6.5.2.2.4.
- For references to TS 25.142 [12], the method of test is specified in TS 25.142 [12], subclause 6.6.2.2.4.
- For references to TS 36.141 [9], the method of test is specified in TS 36.141 [9], subclause 6.6.2.4.

### 6.6.4.5 Test requirements

#### 6.6.4.5.1 E-UTRA test requirement

For E-UTRA, the test requirement is specified in TS 36.141 [9] subclause 6.6.2.5.

#### 6.6.4.5.2 UTRA FDD test requirement

For UTRA FDD, the test requirement is specified in TS 25.141 [10] subclause 6.5.2.2.5.

#### 6.6.4.5.3 UTRA TDD test requirement

For UTRA TDD, the test requirement is specified in TS 25.142 [12] subclause 6.6.2.2.5.

## 6.7 Transmitter intermodulation

### 6.7.1 Definition and applicability

The transmit intermodulation requirement is a measure of the capability of the transmitter to inhibit the generation of signals in its non linear elements caused by presence of the own transmit signal and an interfering signal reaching the transmitter via the antenna. The requirement applies during the transmitter ON period and the transmitter transient period. The transmitter intermodulation level is the power of the intermodulation products when an interfering signal is injected into the antenna connector.

### 6.7.2 Minimum requirement

The minimum requirement is in TS 37.104 [2] subclause 6.7.1, 6.7.2 and 6.7.3.

### 6.7.3 Test purpose

The test purpose is to verify the ability of the MSR BS transmitter to restrict the generation of intermodulation products in its non linear elements caused by presence of the wanted signal and an interfering signal reaching the transmitter via the antenna to below specified levels.

### 6.7.4 Method of test

#### 6.7.4.1 Initial conditions

Test environment: normal; see Annex B.2.

RF bandwidth position to be tested: according to the initial conditions specified in subclauses 6.6.1, 6.6.2 and 6.6.4.

Connect the signal analyzer to the Base Station antenna connector as shown in Annex D.1.2.

#### 6.7.4.2 Procedure

##### 6.7.4.2.1 General minimum requirement test procedure

- 1) Set the BS to transmit the test signal according to clause 5 for requirement 6.6.1 at maximum output power according to the applicable test configuration.
- 2) Generate the interfering signal using E-TM1.1 as defined in as defined in TS 36.141 [9] subclause 6.1.1.1, with 5 MHz channel bandwidth, at a centre frequency offset according to the conditions in Table 6.7.1-1 in TS 37.104 [2], but exclude interference frequencies that are outside of the allocated downlink operating band.
- 3) Adjust ATT1 so that level of the E-UTRA modulated interfering signal is as defined in subclause in Table 6.7.1-1 in TS 37.104 [2].
- 4) If the test signal is applicable according to clause 5, perform the Out-of-band emission tests as specified in subclauses 6.6.2 and 6.6.4, for all third and fifth order intermodulation products which appear in the frequency ranges defined in subclauses 6.6.2 and 6.6.4. The width of the intermodulation products shall be taken into account.
- 5) If the test signal is applicable according to clause 5, perform the Transmitter spurious emissions test as specified in subclause 6.6.1, for all third and fifth order intermodulation products which appear in the frequency ranges defined in subclause 6.6.1. The width of the intermodulation products shall be taken into account.
- 6) Verify that the emission level does not exceed the required level with the exception of interfering signal frequencies.

- 7) Repeat the test for the remaining interfering signal centre frequency offsets according to the conditions of Table 6.7.1-1 in TS 37.104 [2].
- 8) Repeat the test for the remaining test signals defined in clause 5 for requirements 6.6.1, 6.6.2 and 6.6.4.

NOTE: The third order intermodulation products are centred at  $2F1 \pm F2$  and  $2F2 \pm F1$ . The fifth order intermodulation products are centred at  $3F1 \pm 2F2$ ,  $3F2 \pm 2F1$ ,  $4F1 \pm F2$ , and  $4F2 \pm F1$  where  $F1$  represents the test signal centre frequency and  $F2$  represents the interfering signal centre frequency. The widths of intermodulation products are

- $(n \cdot BW_{F1} + m \cdot 5\text{MHz})$  for the  $nF1 \pm mF2$  products
- $(n \cdot 5\text{MHz} + m \cdot BW_{F1})$  for the  $nF2 \pm mF1$  products

where  $BW_{F1}$  represents the test signal RF bandwidth, or channel bandwidth in case of single carrier.

#### 6.7.4.2.2 Additional minimum requirement (BC2) test procedure

- 1) Set the BS to transmit the test signal according to clause 5 for requirement 6.6.1 at maximum output power according to the applicable test configuration.
- 2) Generate a CW signal as the interfering signal with a centre frequency offset of 0.8 MHz, but exclude interference frequencies that are outside of the allocated downlink operating band.
- 3) Adjust ATT1 so that level of the interfering signal is as defined in Table 6.7.2-1 in TS 37.104 [2].
- 4) If the test signal is applicable according to clause 5, perform the Out-of-band emission tests as specified in subclauses 6.6.2 and 6.6.4, for all third and fifth order intermodulation products which appear in the frequency ranges defined in subclauses 6.6.2 and 6.6.4.
- 5) If the test signal is applicable according to clause 5, perform the Transmitter spurious emissions test as specified in subclause 6.6.1, for all third and fifth order intermodulation products which appear in the frequency ranges defined in subclause 6.6.1.
- 6) Verify that the emission level does not exceed the required level with the exception of interfering signal frequencies.
- 7) Repeat the test for interfering signal centre frequency offsets of 2.0 MHz, 3.2MHz and 6.2 MHz.
- 8) Repeat the test for the remaining test signals defined in clause 5 for requirements 6.6.1, 6.6.2 and 6.6.4.

NOTE: The third order intermodulation products are centred at  $2F1 \pm F2$  and  $2F2 \pm F1$ . The fifth order intermodulation products are centred at  $3F1 \pm 2F2$ ,  $3F2 \pm 2F1$ ,  $4F1 \pm F2$ , and  $4F2 \pm F1$  where  $F1$  represents the test signal centre frequency and  $F2$  represents the interfering signal centre frequency. The widths of intermodulation products are

- $(n \cdot BW_{F1})$  for the  $nF1 \pm mF2$  products
- $(m \cdot BW_{F1})$  for the  $nF2 \pm mF1$  products

where  $BW_{F1}$  represents the test signal RF bandwidth or channel bandwidth in case of single carrier.

#### 6.7.4.2.3 Additional minimum requirement (BC3) test procedure

- 1) Set the BS to transmit the test signal according to clause 5 for requirement 6.6.1 at maximum output power according to the applicable test configuration.
- 2) Generate the interfering signal according to Table 6.38A in TS 25.142 [12] at a centre frequency offset according to the conditions in Table 6.7.3-1 in TS 37.104 [2], but exclude interference frequencies that are outside of the allocated downlink operating band.
- 3) Adjust ATT1 so that level of the modulated interfering signal is as defined in Table 6.7.3-1 in TS 37.104 [2].

- 4) If the test signal is applicable according to clause 5, perform the Out-of-band emission tests as specified in subclauses 6.6.2 and 6.6.4, for all third and fifth order intermodulation products which appear in the frequency ranges defined in subclauses 6.6.2 and 6.6.4. The width of the intermodulation products shall be taken into account.
- 5) If the test signal is applicable according to clause 5, perform the Transmitter spurious emissions test as specified in subclause 6.6.1, for all third and fifth order intermodulation products which appear in the frequency ranges defined in subclause 6.6.1. The width of the intermodulation products shall be taken into account.
- 6) Verify that the emission level does not exceed the required level with the exception of interfering signal frequencies.
- 7) Repeat the test for the remaining interfering signal centre frequency offsets according to the conditions of Table 6.7.3-1 in TS 37.104 [2].
- 8) Repeat the test for the remaining test models and physical channels in Table 4.9.2-1.

NOTE: The third order intermodulation products are centred at  $2F1 \pm F2$  and  $2F2 \pm F1$ . The fifth order intermodulation products are centred at  $3F1 \pm 2F2$ ,  $3F2 \pm 2F1$ ,  $4F1 \pm F2$ , and  $4F2 \pm F1$  where  $F1$  represents the test signal centre frequency and  $F2$  represents the interfering signal centre frequency. The widths of intermodulation products are

- $(n \cdot BW_{F1} + m \cdot 1.6\text{MHz})$  for the  $nF1 \pm mF2$  products
- $(n \cdot 1.6\text{MHz} + m \cdot BW_{F1})$  for the  $nF2 \pm mF1$  products

where  $BW_{F1}$  represents the test signal RF bandwidth or channel bandwidth in case of single carrier.

## 6.7.5 Test requirements

### 6.7.5.1 General test requirement

In the frequency range relevant for this test, the transmitter intermodulation level shall not exceed the unwanted emission limits in subclause 6.6 in the presence of a wanted signal and an interfering signal according to Table 6.7.1-1 in TS 37.104 [2] for BS operation in BC1, BC2 and BC3. The measurement may be limited to frequencies on which third and fifth order intermodulation products appear, considering the width of these products.

### 6.7.5.2 Additional test requirement (BC2)

In the frequency range relevant for this test, the transmitter intermodulation level shall not exceed the unwanted emission limits in subclause 6.6 in the presence of a wanted signal and an interfering signal according to Table 6.7.2-1 in TS 37.104 [2] for BS operation in BC2. The measurement may be limited to frequencies on which third and fifth order intermodulation products appear, considering the width of these products.

### 6.7.5.3 Additional test requirement (BC3)

In the frequency range relevant for this test, the transmitter intermodulation level shall not exceed the unwanted emission limits in subclause 6.6 in the presence of a wanted signal and an interfering signal according to Table 6.7.3-1 in TS 37.104 [2] for BS operation in BC3. The measurement may be limited to frequencies on which third and fifth order intermodulation products appear, considering the width of these products.

---

## 7 Receiver characteristics

### 7.1 General

General test conditions for receiver tests are given in clause 4, including interpretation of measurement results and configurations for testing. BS configurations for the tests are defined in subclause 4.10.

Unless otherwise stated the requirements in clause 7 apply during the Base Station receive period.

## 7.2 Reference sensitivity level

### 7.2.1 Definition and applicability

The reference sensitivity power level PREFSENS is the minimum mean power received at the antenna connector at which a reference performance requirement shall be met for a specified reference measurement channel.

Additional details are in TS 36.141 [9] subclause 7.2, TS 25.141 [10] subclause 7.2, TS 25.142 [12] subclause 7.2, and TS 51.021 [11] subclauses 7.3 and 7.4.

### 7.2.2 Minimum requirement

The minimum requirement is in TS 37.104 [2] subclauses 7.2.1, 7.2.2, 7.2.3, and 7.2.4.

### 7.2.3 Test purpose

To verify that at the BS Reference sensitivity level the performance requirements shall be met for a specified reference measurement channel.

### 7.2.4 Method of test

For this requirement Tables 5.1-1 and 5.1-2 refer to single-RAT specifications; see clause 5. The following shall apply:

- For references to TS 51.021 [11], the method of test is specified in TS 51.021 [11], subclauses 7.3 and 7.4.
- For references to TS 25.141 [10], the method of test is specified in TS 25.141 [10], subclause 7.2.4.
- For references to TS 25.142 [12], the method of test is specified in TS 25.142 [12], subclause 7.2.4.
- For references to TS 36.141 [9], the method of test is specified in TS 36.141 [9], subclause 7.2.4.

### 7.2.5 Test requirements

For E-UTRA the test requirement is in TS 36.141 [9] subclause 7.2.5.

For UTRA-FDD the test requirement is in TS 25.141 [10] subclause 7.2.5.

For UTRA-TDD the test requirement is in TS 25.142 [12] subclause 7.2.5.

For GSM-EDGE the test requirement is in TS 51.021 [11] subclauses 7.3 and 7.4.

## 7.3 Dynamic range

### 7.3.1 Definition and applicability

The dynamic range is a measure of the capability of the receiver to receive a wanted signal in the presence of an interfering signal inside the received channel bandwidth or the capability of receiving high level of the wanted signal.

### 7.3.2 Minimum requirement

The minimum requirement is in TS 37.104 [2] subclauses 7.3.1, 7.3.2, 7.3.3, and 7.3.4.

### 7.3.3 Test purpose

To verify that at the BS receiver dynamic range, the receiver performance shall fulfil the specified limit.

## 7.3.4 Method of test

For this requirement Tables 5.1-1 and 5.1-2 refer to single-RAT specifications; see clause 5. The following shall apply:

- For references to TS 51.021 [11], the method of test is specified in TS 51.021 [11], subclause 7.1.
- For references to TS 25.141 [10], the method of test is specified in TS 25.141 [10], subclause 7.3.4.
- For references to TS 25.142 [12], the method of test is specified in TS 25.142 [12], subclause 7.3.4.
- For references to TS 36.141 [9], the method of test is specified in TS 36.141 [9], subclause 7.3.4.

## 7.3.5 Test requirements

For E-UTRA the test requirement is in TS 36.141 [9] subclause 7.3.5.

For UTRA-FDD the test requirement is in TS 25.141 [10] subclause 7.3.5.

For UTRA-TDD the test requirement is in TS 25.142 [12] subclause 7.3.5.

For GSM-EDGE the test requirement is in TS 51.021 [11] subclause 7.1.

## 7.4 In-band selectivity and blocking

### 7.4.1 Definition and applicability

The in-band selectivity and blocking characteristics are measures of the receiver ability to receive a wanted signal at its assigned channel in the presence of an unwanted interferer inside the operating band and are defined by a wideband and a narrowband blocking requirement.

### 7.4.2 Minimum requirement

The minimum requirement is in TS 37.104 [2] subclauses 7.4.1, 7.4.2, 7.4.3, and 7.4.4, and 7.4.5.

### 7.4.3 Test purpose

The test stresses the ability of the BS receiver to withstand high-level interference from unwanted signals at specified frequency offsets without undue degradation of its sensitivity.

### 7.4.4 Method of test

#### 7.4.4.1 Initial conditions

Test environment: Normal; see Annex B.2.

RF bandwidth position to be tested:  $M_{\text{RFBW}}$ , see subclause 4.9.1.

- 1) Set up the equipment as shown in Annex D.2.1.
- 2) Start to transmit according to applicable reference measurement channel to the BS under test as follows:
  - For E-UTRA see Annex A.1 in TS 36.141 [9].
  - For UTRA FDD see Annex A.2 in TS 25.141 [10].
  - For UTRA TDD see Annex A.2.1 in TS 25.142 [12].
  - For GSM see subclause 7.6.2 in TS 52.021 [11] and Annex P in TS 45.005 [6] for reference channels to test.

#### 7.4.4.2 Procedure for general blocking

- 1) Adjust the signal generators to the type of interfering signal, levels and the frequency offsets as specified in Table 7.4.5.1-1.
- 2) The interfering signal shall be swept with a step size of 1 MHz starting from the minimum offset to the channel edges of the wanted signals as specified in Table 7.4.5.1-1
- 3) Measure the performance of the wanted signal at the BS receiver, as defined in subclause 7.4.5, for the relevant carriers specified by the test configuration in subclause 4.8.

#### 7.4.4.3 Procedure for narrowband blocking

- 1) Adjust the signal generators to the type of interfering signal, levels and the frequency offsets as specified in Table 7.4.5.2-1
- 2) Set-up and sweep the interfering RB centre frequency offset to the channel edge of the wanted signal according to Table 7.4.5.2-1.
- 3) Measure the performance of the wanted signal at the BS receiver, as defined in subclause 7.4.5, for the relevant carriers specified by the test configuration in subclause 4.8.

#### 7.4.4.4 Procedure for additional narrowband blocking for GSM/EDGE

The GSM/EDGE in-band blocking method of test is stated in TS 51.021 [11], applicable parts of subclause 7.6.

The conditions specified in TS 45.005 [6], Annex P.2.1 apply for GSM/EDGE in-band narrowband blocking.

#### 7.4.4.5 Procedure for GSM/EDGE AM suppression

The GSM/EDGE in-band blocking method of test is stated in TS 51.021 [11], applicable parts of subclause 7.8.

The conditions specified in TS 45.005 [6], Annex P.2.3 apply for GSM/EDGE AM suppression.

#### 7.4.4.6 Procedure for additional BC3 blocking requirement

- 1) Adjust the signal generators to the type of interfering signal, levels and the frequency offsets as specified in Table 7.4.5.5-1
- 2) Measure the performance of the wanted signal at the BS receiver, as defined in subclause 7.4.5, for the relevant carriers specified by the test configuration in subclause 4.8.

### 7.4.5 Test requirements

#### 7.4.5.1 General blocking test requirement

For the general blocking requirement, the interfering signal shall be a UTRA FDD signal as specified in Annex A.1.

For the wanted and interfering signal coupled to the Base Station antenna input, using the parameters in Table 7.4.5.1-1, the following requirements shall be met:

- For any measured E-UTRA carrier, the throughput shall be  $\geq 95\%$  of the maximum throughput of the reference measurement channel defined in TS 36.104 [5], subclause 7.2.
- For any measured UTRA FDD carrier, the BER shall not exceed 0.001 for the reference measurement channel defined in TS 25.104 [3], subclause 7.2.
- For any measured UTRA TDD carrier, the BER shall not exceed 0.001 for the reference measurement channel defined in TS 25.105 [4], subclause 7.2.
- For any measured GSM/EDGE carrier, the conditions are specified in TS 45.005 [6], Annex P.2.1.

Table 7.4.5.1-1: General blocking test requirement

Operating Band Number	Centre Frequency of Interfering Signal [MHz]	Interfering Signal mean power [dBm]	Wanted Signal mean power [dBm]	Interfering signal centre frequency minimum frequency offset from the RF bandwidth edge [MHz]
1-7, 9-11, 13, 14, 18, 19, 21, 33-40	(F <sub>UL_low</sub> -20) to (F <sub>UL_high</sub> +20)	-40	P <sub>REFSENS</sub> + x dB*	±7.5
8	(F <sub>UL_low</sub> -20) to (F <sub>UL_high</sub> +10)			
12	(F <sub>UL_low</sub> -20) to (F <sub>UL_high</sub> +12)			
17	(F <sub>UL_low</sub> -20) to (F <sub>UL_high</sub> +18)			
20	(F <sub>UL_low</sub> -11) to (F <sub>UL_high</sub> +20)			
NOTE*: P <sub>REFSENS</sub> depends on the RAT and on the channel bandwidth, see subclause 7.2. NOTE**: "x" is equal to 6 in case of E-UTRA or UTRA wanted signals and equal to 3 in case of GSM/EDGE wanted signal.				

### 7.4.5.2 General narrowband blocking test requirement

For the narrowband blocking requirement, the interfering signal shall be an E-UTRA 1RB signal as specified in Annex A.3.

For the wanted and interfering signal coupled to the Base Station antenna input, using the parameters in Table 7.4.5.2-1 the following requirements shall be met:

- For any measured E-UTRA carrier, the throughput shall be  $\geq 95\%$  of the maximum throughput of the reference measurement channel defined in TS 36.104 [5], subclause 7.2.
- For any measured UTRA FDD carrier, the BER shall not exceed 0.001 for the reference measurement channel defined in TS 25.104 [3], subclause 7.2.
- For any measured UTRA TDD carrier, the BER shall not exceed 0.001 for the reference measurement channel defined in TS 25.105 [4], subclause 7.2.
- For any measured GSM/EDGE carrier, the conditions are specified in TS 45.005 [6], Annex P.2.1.

Table 7.4.5.2-1: Narrowband blocking requirement

RAT of the carrier	Wanted signal mean power [dBm]	Interfering signal mean power [dBm]	Interfering RB centre frequency offset from the RF bandwidth edge [kHz]
E-UTRA, UTRA and GSM/EDGE	P <sub>REFSENS</sub> + x dB*	-49	$\pm(240 + m \cdot 180)$ , m=0, 1, 2, 3, 4, 9, 14, 19, 24
NOTE*: P <sub>REFSENS</sub> depends on the RAT and on the channel bandwidth, see subclause 7.2. NOTE**: "x" is equal to 6 in case of E-UTRA or UTRA wanted signals and equal to 3 in case of GSM/EDGE wanted signal. NOTE***: Interfering signal (E-UTRA 3MHz) consisting of one resource block positioned at the stated offset, the channel bandwidth of the interfering signal is located adjacently to the RF bandwidth edge.			

### 7.4.5.3 Additional narrowband blocking test requirement for GSM/EDGE

The GSM/EDGE in-band blocking test requirements are stated in TS 51.021 [11], applicable parts of subclause 7.6.

The conditions specified in TS 45.005 [6], Annex P.2.1 apply for GSM/EDGE in-band narrowband blocking.



#### 7.4.5.4 GSM/EDGE test requirements for AM suppression

The GSM/EDGE in-band blocking test requirements are stated in TS 51.021 [11], applicable parts of subclause 7.8.

The conditions specified in TS 45.005 [6], Annex P.2.3 apply for GSM/EDGE AM suppression.

#### 7.4.5.5 Additional BC3 blocking test requirement

The interfering signal is a 1.28 Mcps UTRA TDD modulated signal as specified in Annex A.2.

For the wanted and interfering signal coupled to the Base Station antenna input, using the parameters in Table 7.4.5.5-1, the following requirements shall be met:

- For any measured E-UTRA TDD carrier, the throughput shall be  $\geq 95\%$  of the maximum throughput of the reference measurement channel defined in TS 36.104 [5], subclause 7.2.
- For any measured UTRA TDD carrier, the BER shall not exceed 0.001 for the reference measurement channel defined in TS 25.105 [4], subclause 7.2.

**Table 7.4.5.5-1: Additional blocking requirement for Band Category 3**

Operating Band	Centre Frequency of Interfering Signal [MHz]	Interfering Signal mean power [dBm]	Wanted Signal mean power [dBm]	Interfering signal centre frequency minimum frequency offset from the RF bandwidth edge [MHz]
33 - 40	( $F_{UL\_low} - 20$ ) to ( $F_{UL\_high} + 20$ )	-40,	$P_{REFSENS} + 6$ dB*	$\pm 2.4$
NOTE*: $P_{REFSENS}$ depends on the RAT and on the channel bandwidth, see section 7.2.				

## 7.5 Out-of-band blocking

### 7.5.1 Definition and applicability

The Out-of-band blocking characteristic is a measure of the receiver ability to receive a wanted signal at its assigned channel in the presence of an unwanted interferer outside the uplink operating band.

The blocking performance requirement applies as specified in the Table 7.5.5.1-1 and Table 7.5.5.2-1.

### 7.5.2 Minimum requirement

The general minimum requirement is in TS 37.104 [2] subclause 7.5.1. The co-location minimum requirement is in TS 37.104 [2] subclause 7.5.2.

### 7.5.3 Test purpose

The test stresses the ability of the BS receiver to withstand high-level interference from unwanted signals at specified frequency bands, without undue degradation of its sensitivity.

### 7.5.4 Method of test

#### 7.5.4.1 Initial conditions

Test environment: normal; see Annex B.2.

RF bandwidth position to be tested:  $M_{RFBW}$  see subclause 4.9.1.

- 1) Set up the equipment as shown in Annex D.2.1.

2) Start to transmit according to reference measurement channel to the BS under test as follows:

- For E-UTRA see Annex A.1 in TS 36.141 [9].
- For UTRA FDD see Annex A.2 in TS 25.141 [10].
- For UTRA TDD see Annex A.2.1 in TS 25.142 [12].
- For GSM see subclause 7.6.2 in TS 52.021 [11] and Annex P in TS 45.005 [6] for reference channels to test.

#### 7.5.4.2 Procedure

- 1) Adjust the signal generators to the type of interfering signals, levels and the frequency offsets as specified for general test requirements in Table 7.5.5.1-1 and, when applicable, for co-location test requirements in Table 7.5.5.2-1.
- 2) The CW interfering signal shall be swept with a step size of 1 MHz within the specified range.
- 3) Measure the performance of the wanted signal at the BS receiver, as defined in the subclause 7.5.5, for the relevant carriers specified by the test configuration in subclause 4.8.

### 7.5.5 Test requirements

#### 7.5.5.1 General out-of-band blocking test requirements

For a wanted and an interfering signal coupled to BS antenna input using the parameters in Table 7.5.5.1-1, the following requirements shall be met:

- For any measured E-UTRA carrier, the throughput shall be  $\geq 95\%$  of the maximum throughput of the reference measurement channel defined in TS 36.104 [5], subclause 7.2.
- For any measured UTRA FDD carrier, the BER shall not exceed 0.001 for the reference measurement channel defined in TS 25.104 [3], subclause 7.2.
- For any measured UTRA TDD carrier, the BER shall not exceed 0.001 for the reference measurement channel defined in TS 25.105 [4], subclause 7.2.
- For any measured GSM/EDGE carrier, the conditions are specified in TS 45.005 [6], Annex P.2.1.

**Table 7.5.5.1-1: Blocking performance requirement**

Operating Band Number	Centre Frequency of Interfering Signal [MHz]	Interfering Signal mean power [dBm]	Wanted Signal mean power [dBm]	Type of Interfering Signal
1-7, 9-11, 13, 14, 18, 19, 21, 33-40	1 to $(F_{UL\_low} - 20)$ $(F_{UL\_high} + 20)$ to 12750	-15	$P_{REFSENS} + x$ dB*	CW carrier
8	1 to $(F_{UL\_low} - 20)$ $(F_{UL\_high} + 10)$ to 12750	-15	$P_{REFSENS} + x$ dB*	CW carrier
12	1 to $(F_{UL\_low} - 20)$ $(F_{UL\_high} + 12)$ to 12750	-15	$P_{REFSENS} + x$ dB*	CW carrier
17	1 to $(F_{UL\_low} - 20)$ $(F_{UL\_high} + 18)$ to 12750	-15	$P_{REFSENS} + x$ dB*	CW carrier
20	1 to $(F_{UL\_low} - 11)$ $(F_{UL\_high} + 20)$ to 12750	-15	$P_{REFSENS} + x$ dB*	CW carrier
NOTE*: $P_{REFSENS}$ depends on the RAT and the channel bandwidth, see subclause 7.2. "x" is equal to 6 in case of E-UTRA or UTRA wanted signals and equal to 3 in case of GSM/EDGE wanted signal.				

### 7.5.5.2 Co-location test requirements

This additional blocking requirement may be applied for the protection of BS receivers when E-UTRA BS, UTRA, CDMA or GSM/EDGE operating in a different frequency band are co-located with a BS.

The requirements in this subclause assume a 30 dB coupling loss between the interfering transmitter and the BS receiver.

NOTE: For co-location with UTRA, the requirements are based on co-location with Wide Area UTRA FDD or TDD Base Stations.

For a wanted and an interfering signal coupled to BS antenna input using the parameters in Table 7.5.5.2-1, the following requirements shall be met:

- For any measured E-UTRA carrier, the throughput shall be  $\geq 95\%$  of the maximum throughput of the reference measurement channel defined in TS 36.104 [5], subclause 7.2.
- For any measured UTRA FDD carrier, the BER shall not exceed 0.001 for the reference measurement channel defined in TS 25.104 [3], subclause 7.2.
- For any measured UTRA TDD carrier, the BER shall not exceed 0.001 for the reference measurement channel defined in TS 25.105 [4], subclause 7.2.
- For any measured GSM/EDGE carrier, the conditions are specified in TS 45.005 [6], Annex P.2.1.

Table 7.5.2-1: Blocking requirement for when co-located with BS in other frequency bands.

Type of co-located BS	Centre Frequency of Interfering Signal (MHz)	Interfering Signal mean power (dBm)	Wanted Signal mean power (dBm)	Type of Interfering Signal
Macro GSM850 or CDMA850	869 – 894	+16	$P_{\text{REFSENS}} + x \text{ dB}^*$	CW carrier
Macro GSM900	921 – 960	+16	$P_{\text{REFSENS}} + x \text{ dB}^*$	CW carrier
Macro DCS1800	1805 – 1880 (Note 4)	+16	$P_{\text{REFSENS}} + x \text{ dB}^*$	CW carrier
Macro PCS1900	1930 – 1990	+16	$P_{\text{REFSENS}} + x \text{ dB}^*$	CW carrier
UTRA FDD Band I or E-UTRA Band 1	2110 – 2170	+16	$P_{\text{REFSENS}} + x \text{ dB}^*$	CW carrier
UTRA FDD Band II or E-UTRA Band 2	1930 – 1990	+16	$P_{\text{REFSENS}} + x \text{ dB}^*$	CW carrier
UTRA FDD Band III or E-UTRA Band 3	1805 – 1880 (Note 4)	+16	$P_{\text{REFSENS}} + x \text{ dB}^*$	CW carrier
UTRA FDD Band IV or E-UTRA Band 4	2110 – 2155	+16	$P_{\text{REFSENS}} + x \text{ dB}^*$	CW carrier
UTRA FDD Band V or E-UTRA Band 5	869 – 894	+16	$P_{\text{REFSENS}} + x \text{ dB}^*$	CW carrier
UTRA FDD Band VI or E-UTRA Band 6	875 – 885	+16	$P_{\text{REFSENS}} + x \text{ dB}^*$	CW carrier
UTRA FDD Band VII or E-UTRA Band 7	2620 – 2690	+16	$P_{\text{REFSENS}} + x \text{ dB}^*$	CW carrier
UTRA FDD Band VIII or E-UTRA Band 8	925 – 960	+16	$P_{\text{REFSENS}} + x \text{ dB}^*$	CW carrier
UTRA FDD Band IX or E-UTRA Band 9	1844.9 – 1879.9	+16	$P_{\text{REFSENS}} + x \text{ dB}^*$	CW carrier
UTRA FDD Band X or E-UTRA Band 10	2110 – 2170	+16	$P_{\text{REFSENS}} + x \text{ dB}^*$	CW carrier
UTRA FDD Band XI or E-UTRA Band 11	1475.9 - 1495.9	+16	$P_{\text{REFSENS}} + x \text{ dB}^*$	CW carrier
UTRA FDD Band XII or E-UTRA Band 12	728 - 746	+16	$P_{\text{REFSENS}} + x \text{ dB}^*$	CW carrier
UTRA FDD Band XIII or E-UTRA Band 13	746 - 756	+16	$P_{\text{REFSENS}} + x \text{ dB}^*$	CW carrier
UTRA FDD Band XIV or E-UTRA Band 14	758 - 768	+16	$P_{\text{REFSENS}} + x \text{ dB}^*$	CW carrier
E-UTRA Band 17	734 - 746	+16	$P_{\text{REFSENS}} + x \text{ dB}^*$	CW carrier
E-UTRA Band 18	860 - 875	+16	$P_{\text{REFSENS}} + x \text{ dB}^*$	CW carrier
UTRA FDD Band XIX or E-UTRA Band 19	875 - 890	+16	$P_{\text{REFSENS}} + x \text{ dB}^*$	CW carrier
UTRA FDD Band XX or E-UTRA Band 20	791 - 821	+16	$P_{\text{REFSENS}} + x \text{ dB}^*$	CW carrier
UTRA FDD Band XXI or E-UTRA Band 21	1495.9 – 1510.9	+16	$P_{\text{REFSENS}} + x \text{ dB}^*$	CW carrier
UTRA TDD in Band a)	1900-1920 2010-2025	+16	$P_{\text{REFSENS}} + x \text{ dB}^*$	CW carrier
E-UTRA TDD in Band 33	1900-1920	+16	$P_{\text{REFSENS}} + x \text{ dB}^*$	CW carrier
E-UTRA TDD in Band 34	2010-2025	+16	$P_{\text{REFSENS}} + x \text{ dB}^*$	CW carrier
UTRA TDD in Band b)	1850-1910 1930-1990	+16	$P_{\text{REFSENS}} + x \text{ dB}^*$	CW carrier
E-UTRA TDD in Band 35	1850-1910	+16	$P_{\text{REFSENS}} + x \text{ dB}^*$	CW carrier
E-UTRA TDD in Band 36	1930-1990	+16	$P_{\text{REFSENS}} + x \text{ dB}^*$	CW carrier
UTRA TDD in Band c) or E-UTRA TDD in Band 37	1910-1930	+16	$P_{\text{REFSENS}} + x \text{ dB}^*$	CW carrier
UTRA TDD in Band d) or E-UTRA in Band 38	2570-2620	+16	$P_{\text{REFSENS}} + x \text{ dB}^*$	CW carrier
E-UTRA in Band 39	1880-1920	+16	$P_{\text{REFSENS}} + x \text{ dB}^*$	CW carrier
E-UTRA in Band 40	2300-2400	+16	$P_{\text{REFSENS}} + x \text{ dB}^*$	CW carrier
NOTE 1 (*): $P_{\text{REFSENS}}$ depends on the RAT and the channel bandwidth, see subclause 7.2. "x" is equal to 3 in case of GSM/EDGE wanted signal and equal to 6 in case of UTRA or E-UTRA wanted signals.				
NOTE 2: Except for a BS operating in Band 13, these requirements do not apply when the				

interfering signal falls within the uplink operating band or in the 10 MHz immediately outside the uplink operating band.

For a BS operating in band 13 the requirements do not apply when the interfering signal falls within the frequency range 768-797 MHz.

NOTE 3: Some combinations of bands may not be possible to co-site based on the requirements above. The current state-of-the-art technology does not allow a single generic solution for co-location of UTRA TDD or E-UTRA TDD with E-UTRA FDD on adjacent frequencies for 30dB BS-BS minimum coupling loss. However, there are certain site-engineering solutions that can be used. These techniques are addressed in TR 25.942 [7].

NOTE 4: In China, the blocking requirement for co-location with DCS1800 and Band III BS is only applicable in the frequency range 1805-1850MHz.

## 7.6 Receiver spurious emissions

### 7.6.1 Definition and applicability

The receiver spurious emissions power is the power of emissions generated or amplified in a receiver that appear at the BS receiver antenna connector. The requirements apply to all BS with separate RX and TX antenna ports. In this case for FDD BS the test shall be performed when both TX and RX are on, with the TX port terminated.

For TDD BS with common RX and TX antenna port the requirement applies during the Transmitter OFF period. For FDD BS with common RX and TX antenna port the transmitter spurious emission limits as specified in subclause 6.6.1 are valid.

### 7.6.2 Minimum requirements

The minimum requirement is in TS 37.104 [2] subclause 7.6.1.

### 7.6.3 Test purpose

The test purpose is to verify the ability of the BS to limit the interference caused by receiver spurious emissions to other systems.

### 7.6.4 Method of test

#### 7.6.4.1 Initial conditions

Test environment: Normal; see Annex B.2.

RF bandwidth position to be tested:  $M_{\text{RFBW}}$ , see subclause 4.9.1.

- 1) Set up the equipment as shown in Annex D.2.1.

#### 7.6.4.2 Procedure

- 1) Set the measurement equipment parameters as specified in Table 7.6.5.1-1. For BC2, the parameters in Table 7.6.5.2-1 apply in addition.
- 2) Start BS transmission according to the applicable test configuration in 4.8 at Pmax.
- 3) Measure the spurious emissions over each frequency range described in subclause 7.6.5.

### 7.6.5 Test requirements

#### 7.6.5.1 General test requirements

The power of any spurious emission shall not exceed the levels in Table 7.6.5.1-1.

**Table 7.6.5.1-1: General spurious emission test requirement**

Frequency range	Maximum level	Measurement Bandwidth	Note
30 MHz - 1 GHz	-57 dBm	100 kHz	
1 GHz - 12.75 GHz	-47 dBm	1 MHz	
NOTE: The frequency range from $F_{\text{BW RF,DL,low}} - 10$ MHz to $F_{\text{BW RF,DL,high}} + 10$ MHz may be excluded from the requirement.			

In addition to the requirements in Table 7.6.5.1-1, the power of any spurious emission shall not exceed the additional spurious emissions requirements in subclause 6.6.1.5.5 and in case of FDD BS (for BC1 and BC2) emission shall not exceed the levels specified for protection of the BS receivers of own or different BS in subclause 6.6.1.5.4. In addition, the requirements for co-location with other Base Stations specified in subclause 6.6.1.5.6 may also be applied.

### 7.6.5.2 Additional test requirement for BC2 (Category B)

For a BS operating in Band Category 2 and where Category B spurious emissions apply, the power of any spurious emissions shall not exceed the limits in Table 7.6.5.2-1.

**Table 7.6.5.2-1: Additional BS spurious emissions limits for BC2, Category B**

Frequency range	Frequency offset from transmitter operating band edge	Maximum level	Measurement Bandwidth
30 MHz – 1 GHz	10 – 20 MHz	-57 dBm	300 kHz
	20 – 30 MHz	-57 dBm	1 MHz
	$\geq 30$ MHz	-57 dBm	3 MHz
1 GHz – 12.75 GHz	$\geq 30$ MHz	-47 dBm	3 MHz

## 7.7 Receiver intermodulation

### 7.7.1 Definition and applicability

Third and higher order mixing of the two interfering RF signals can produce an interfering signal in the band of the desired channel. Intermodulation response rejection is a measure of the capability of the receiver to receive a wanted signal on its assigned channel frequency in the presence of two interfering signals which have a specific frequency relationship to the wanted signal.

### 7.7.2 Minimum requirement

The minimum requirement is in TS 37.104 [2], subclauses 7.7.1, 7.7.2 and 7.7.3.

### 7.7.3 Test purpose

The test purpose is to verify the ability of the BS receiver to inhibit the generation of intermodulation products in its non-linear elements caused by the presence of two high-level interfering signals at frequencies with a specific relationship to the frequency of the wanted signal.

### 7.7.4 Method of test

#### 7.7.4.1 Initial conditions

Test environment: Normal; see Annex B.2.

RF bandwidth position to be tested:  $M_{\text{RFBW}}$  if TC6 is applicable;  $B_{\text{RFBW}}$  and  $T_{\text{RFBW}}$  for other TC, see subclause 4.9.1.

- 1) Set-up the measurement system as shown in Annex D.2.3.

2) Start to transmit according to reference measurement channel to the BS under test as follows:

- For E-UTRA see Annex A.1 in TS 36.141 [9].
- For UTRA FDD see Annex A.2 in TS 25.141 [10].
- For UTRA TDD see Annex A.2.1 in TS 25.142 [12].
- For GSM see subclause 7.6.2 in TS 52.021 [11] and Annex P in TS 45.005 [6] for reference channels to test.

#### 7.7.4.2 Procedure for general and narrowband intermodulation

- 1) Adjust the signal generators to the type of interfering signals, levels and the frequency offsets as specified in Table 7.7.5.1-1 and Table 7.7.5.1-2 for general intermodulation requirement, and Table 7.7.5.2-1 and Table 7.7.5.2-2 for narrowband intermodulation requirement.
- 2) Measure the performance of the wanted signal at the BS receiver, as defined in subclause 7.7.5.1 and 7.7.5.2, for the relevant carriers specified by the test configuration in subclause 4.8.

#### 7.7.4.3 Procedure for additional narrowband intermodulation for GSM/EDGE

The GSM/EDGE MC-BTS receiver intermodulation method of test is stated in TS 51.021 [11], applicable parts of subclause 7.7, shall apply for GSM/EDGE carriers.

The conditions specified in TS 45.005 [6], Annex P.2.2 apply for the GSM/EDGE intermodulation requirement.

### 7.7.5 Test requirements

#### 7.7.5.1 General intermodulation test requirement

Interfering signals shall be a CW signal and an E-UTRA or UTRA signal, as specified in Annex A.

For the wanted signal at the assigned channel frequency and two interfering signals coupled to the Base Station antenna input, using the parameters in Table 7.7.5.1-1 and 7.7.5.1-2, the following requirements shall be met:

- For any measured E-UTRA carrier, the throughput shall be  $\geq 95\%$  of the maximum throughput of the reference measurement channel defined in TS 36.104 [5], subclause 7.2.
- For any measured UTRA FDD carrier, the BER shall not exceed 0.001 for the reference measurement channel defined in TS 25.104 [3], subclause 7.2.
- For any measured UTRA TDD carrier, the BER shall not exceed 0.001 for the reference measurement channel defined in TS 25.105 [4], subclause 7.2.
- For any measured GSM/EDGE carrier, the conditions are specified in TS 45.005 [6], Annex P.2.2.

**Table 7.7.5.1-1: General intermodulation requirement**

Mean power of interfering signals [dBm]	Wanted Signal mean power [dBm]	Type of interfering signal
-48	$P_{\text{REFSENS}} + X \text{ dB}^*$	See Table 7.7.5.1-2
NOTE*: $P_{\text{REFSENS}}$ depends on the RAT and on the channel bandwidth, see subclause 7.2 in TS 37.104. For E-UTRA channel bandwidths 10, 15 and 20 MHz this requirement shall apply only for a FRC A1-3 mapped to the frequency range at the channel edge adjacent to the interfering signals. "x" is equal to 6 in case of E-UTRA or UTRA wanted signals and equal to 3 in case of GSM/EDGE wanted signal.		

**Table 7.7.5.1-2: Interfering signals for intermodulation requirement**

RAT of the carrier	Interfering signal centre frequency offset from the RF bandwidth edge [MHz]	Type of interfering signal
E-UTRA 1.4 MHz	$\pm 2.0$ (BC1 and BC3) / $\pm 2.1$ (BC2)	CW
	$\pm 4.9$	1.4MHz E-UTRA signal
E-UTRA 3 MHz	$\pm 4.4$ (BC1 and BC3) / $\pm 4.5$ (BC2)	CW
	$\pm 10.5$	3MHz E-UTRA signal
UTRA FDD and E-UTRA 5 MHz	$\pm 7.5$	CW
	$\pm 17.5$	5MHz E-UTRA signal
E-UTRA 10 MHz	$\pm 7.375$	CW
	$\pm 17.5$	5MHz E-UTRA signal
E-UTRA 15 MHz	$\pm 7.25$	CW
	$\pm 17.5$	5MHz E-UTRA signal
E-UTRA 20 MHz	$\pm 7.125$	CW
	$\pm 17.5$	5MHz E-UTRA signal
GSM/EDGE	$\pm 7.575$	CW
	$\pm 17.5$	5MHz E-UTRA signal
1.28 Mcps UTRA TDD	$\pm 2.3$ (BC3)	CW
	$\pm 5.6$ (BC3)	1.28Mcps UTRA TDD signal

### 7.7.5.2 General narrowband intermodulation test requirement

Interfering signals shall be a CW signal and an E-UTRA 1RB signal, as specified in Annex A.

For the wanted signal at the assigned channel frequency and two interfering signals coupled to the Base Station antenna input, using the parameters in Table 7.7.5.2-1 and 7.7.5.2-2, the following requirements shall be met:

- For any measured E-UTRA carrier, the throughput shall be  $\geq 95\%$  of the maximum throughput of the reference measurement channel defined in TS 36.104 [5], subclause 7.2.
- For any measured UTRA FDD carrier, the BER shall not exceed 0.001 for the reference measurement channel defined in TS 25.104 [3], subclause 7.2.
- For any measured UTRA TDD carrier, the BER shall not exceed 0.001 for the reference measurement channel defined in TS 25.105 [4], subclause 7.2.
- For any measured GSM/EDGE carrier, the conditions are specified in TS 45.005 [6], Annex P.2.2.

**Table 7.7.5.2-1: General narrowband intermodulation requirement**

Mean power of interfering signals [dBm]	Wanted Signal mean power [dBm]	Type of interfering signal
-52	$P_{\text{REFSENS}} + X \text{ dB}^*$	See Table 7.7.5.2-2
NOTE*: $P_{\text{REFSENS}}$ depends on the RAT and on the channel bandwidth, see subclause 7.2 in TS 37.104. "x" is equal to 6 in case of E-UTRA or UTRA wanted signals and equal to 3 in case of GSM/EDGE wanted signal.		



**Table 7.7.5.2-2: Interfering signals for narrowband intermodulation requirement**

RAT of the carrier	Interfering signal centre frequency offset from the RF bandwidth edge [kHz]	Type of interfering signal
E-UTRA 1.4 MHz	$\pm 260$ (BC1 and BC3) / $\pm 270$ (BC2)	CW
	$\pm 970$ (BC1 and BC3) / $\pm 790$ (BC2)	1.4 MHz E-UTRA signal, 1 RB*
E-UTRA 3 MHz	$\pm 260$ (BC1 and BC3) / $\pm 270$ (BC2)	CW
	$\pm 960$ (BC1 and BC3) / $\pm 780$ (BC2)	3.0 MHz E-UTRA signal, 1 RB*
E-UTRA 5 MHz	$\pm 360$	CW
	$\pm 1060$	5 MHz E-UTRA signal, 1 RB*
E-UTRA 10 MHz (**)	$\pm 325$	CW
	$\pm 1240$	5 MHz E-UTRA signal, 1 RB*
E-UTRA 15 MHz (**)	$\pm 380$	CW
	$\pm 1600$	5MHz E-UTRA signal, 1 RB*
E-UTRA 20 MHz (**)	$\pm 345$	CW
	$\pm 1780$	5MHz E-UTRA signal, 1 RB*
UTRA FDD	$\pm 345$ (BC1 and BC2)	CW
	$\pm 1780$ (BC1 and BC2)	5MHz E-UTRA signal, 1 RB*
GSM/EDGE	$\pm 340$	CW
	$\pm 880$	5MHz E-UTRA signal, 1 RB*
1.28Mcps UTRA TDD	$\pm 190$ (BC3)	CW
	$\pm 970$ (BC3)	1.4 MHz E-UTRA signal, 1 RB*
NOTE*: Interfering signal consisting of one resource block positioned at the stated offset, the channel bandwidth of the interfering signal is located adjacently to the RF bandwidth edge.		
NOTE**: This requirement shall apply only for an E-UTRA FRC A1-3 mapped to the frequency range at the channel edge adjacent to the interfering signals.		

### 7.7.5.3 Additional narrowband intermodulation test requirement for GSM/EDGE

The GSM/EDGE MC-BTS receiver intermodulation test requirements are stated in TS 51.021 [11], applicable parts of subclause 7.7, shall apply for GSM/EDGE carriers.

The conditions specified in TS 45.005 [6], Annex P.2.2 apply for the GSM/EDGE intermodulation requirement.

## 7.8 In-channel selectivity

### 7.8.1 Definition and applicability

In-channel selectivity (ICS) is a measure of the receiver ability to receive a wanted signal at its assigned resource block locations in the presence of an interfering signal received at a larger power spectral density. In this condition a throughput requirement shall be met for a specified reference measurement channel. This requirement is applicable for E-UTRA carriers only.

### 7.8.2 Minimum requirement

The minimum requirement is in TS 37.104 [2] subclause 7.8.1.

### 7.8.3 Test purpose

The purpose of this test is to verify the BS receiver ability to suppress the IQ leakage.

## 7.8.4 Method of testing

For this requirement Tables 5.1-1 and 5.1-2 refer to single-RAT specifications; see clause 5. The following shall apply:

- For references to TS 36.141 [9], the method of test is specified in TS 36.141 [9], subclause 7.4.4.

## 7.8.5 Test requirements

The test requirements are in TS 36.141 [9], subclause 7.4.5.

---

# 8 Performance requirements

Void

## Annex A (normative): Characteristics of interfering signals

### A.1 UTRA FDD interfering signal

The UTRA FDD interfering signal shall be a DPCH containing the DPCCH and one DPDCH. The data content for each channelization code shall be uncorrelated with each other and to the wanted signal and spread and modulated according to clause 4 of TS 25.213. Further characteristics of DPDCH and DPCCH are specified in Table A.1-1.

**Table A.1-1: Characteristics of UTRA FDD interfering signal**

Channel	Bit Rate	Spreading Factor	Channelization Code	Relative Power
DPDCH	240 kbps	16	4	0 dB
DPCCH	15 kbps	256	0	-5.46 dB
NOTE: The DPDCH and DPCCH settings are chosen to simulate a signal with realistic Peak to Average Ratio.				

### A.2 UTRA TDD interfering signal

The UTRA TDD interfering signal shall be 1.28 Mcps UTRA TDD signal with one code. The data content shall be uncorrelated to the wanted signal. They are specified in Table A.2-1.

**Table A.2-1: Characteristics of UTRA TDD interfering signal**

UTRA TDD option	Type of Interfering Signal
1.28 Mcps UTRA TDD	1,28 Mcps UTRA TDD signal with one code*
* NOTE: The channelisation code ID and Midamble shift shall be different with the wanted signal's.	

### A.3 E-UTRA interfering signal

The E-UTRA interfering signal shall be a PUSCH containing data and reference symbols. Normal CP is used. The data content shall be uncorrelated to the wanted signal and modulated according to clause 5 of TS 36.211. Mapping of PUSCH modulation to receiver requirement are specified in Table A.3-1.

**Table A.3-1: Modulation of the E-UTRA interfering signal**

Receiver requirement	Modulation
Narrowband blocking	QPSK
Receiver intermodulation	QPSK

---

## Annex B (normative): Environmental requirements for the BS equipment

### B.1 General

For each test in the present document, the environmental conditions under which the BS is to be tested are defined. The environmental conditions and class shall be from the relevant IEC specifications or the corresponding ETSI specifications.

---

### B.2 Normal test environment

When a normal test environment is specified for a test, the test should be performed within the minimum and maximum limits of the conditions stated in Table B.1.

**Table B.1: Limits of conditions for Normal Test Environment**

Condition	Minimum	Maximum
Barometric pressure	86 kPa	106 kPa
Temperature	15°C	30°C
Relative Humidity	20 %	85 %
Power supply	Nominal, as declared by the manufacturer	
Vibration	Negligible	

The ranges of barometric pressure, temperature and humidity represent the maximum variation expected in the uncontrolled environment of a test laboratory. If it is not possible to maintain these parameters within the specified limits, the actual values shall be recorded in the test report.

---

### B.3 Extreme test environment

The manufacturer shall declare one of the following:

- 1) The equipment class for the equipment under test, as defined in the IEC 60721-3-3 [17] or ETSI EN 300 019-1-3 [19] ("Stationary use at weather protected locations");
- 2) The equipment class for the equipment under test, as defined in the IEC 60721-3-4 [18] or ETSI EN 300 019-1-4 [20] ("Stationary use at non weather protected locations");
- 3) The equipment that does not comply to the mentioned classes, the relevant classes from IEC 60721 [16] documentation for Temperature, Humidity and Vibration shall be declared.

NOTE: Reduced functionality for conditions that fall out side of the standard operational conditions are not tested in the present document. These may be stated and tested separately.

#### B.3.1 Extreme temperature

When an extreme temperature test environment is specified for a test, the test shall be performed at the standard minimum and maximum operating temperatures defined by the manufacturer's declaration for the equipment under test.

##### **Minimum temperature:**

The test shall be performed with the environment test equipment and methods including the required environmental phenomena into the equipment, conforming to the test procedure of IEC 60068-2-1 [21].

##### **Maximum temperature:**

The test shall be performed with the environmental test equipment and methods including the required environmental phenomena into the equipment, conforming to the test procedure of IEC 60068-2-2 [22].

NOTE: It is recommended that the equipment is made fully operational prior to the equipment being taken to its lower operating temperature.

---

## B.4 Vibration

When vibration conditions are specified for a test, the test shall be performed while the equipment is subjected to a vibration sequence as defined by the manufacturer's declaration for the equipment under test. This shall use the environmental test equipment and methods of inducing the required environmental phenomena in to the equipment, conforming to the test procedure of IEC 60068-2-6 [23]. Other environmental conditions shall be within the ranges specified in clause B.2.

NOTE: The higher levels of vibration may induce undue physical stress in to equipment after a prolonged series of tests. The testing body should only vibrate the equipment during the RF measurement process.

---

## B.5 Power supply

When extreme power supply conditions are specified for a test, the test shall be performed at the standard upper and lower limits of operating voltage defined by manufacturer's declaration for the equipment under test.

### Upper voltage limit:

The equipment shall be supplied with a voltage equal to the upper limit declared by the manufacturer (as measured at the input terminals to the equipment). The tests shall be carried out at the steady state minimum and maximum temperature limits declared by the manufacturer for the equipment, to the methods described in IEC 60068-2-1 [21] Test Ab/Ad and IEC 60068-2-2 [22] Test Bb/Bd: Dry Heat.

### Lower voltage limit:

The equipment shall be supplied with a voltage equal to the lower limit declared by the manufacturer (as measured at the input terminals to the equipment). The tests shall be carried out at the steady state minimum and maximum temperature limits declared by the manufacturer for the equipment, to the methods described in IEC 60068-2-1 [21] Test Ab/Ad and IEC 60068-2-2 [22] Test Bb/Bd: Dry Heat.

---

## B.6 Measurement of test environments

The measurement accuracy of the BS test environments shall be.

Pressure:	±5 kPa.
Temperature:	±2 degrees.
Relative Humidity:	±5 %.
DC Voltage:	±1,0 %.
AC Voltage:	±1,5 %.
Vibration:	10 %.
Vibration frequency:	0,1 Hz.

The above values shall apply unless the test environment is otherwise controlled and the specification for the control of the test environment specifies the uncertainty for the parameter.

---

## Annex C (informative): Test Tolerances and Derivation of test requirements

The test requirements explicitly defined in this specification have been calculated by relaxing the minimum requirements of the core specification using the Test Tolerances defined here. When the Test Tolerance is zero, the test requirement will be the same as the minimum requirement. When the Test Tolerance is non-zero, the test requirements will differ from the minimum requirements, and the formula used for this relaxation is given in the following tables.

Test requirements which are included by reference to TS 25.141 [10], TS 25.142[12], TS 36.141[9] or TS 51.021[11] have been calculated within the referred test specification using the Test Tolerances defined therein.

The Test Tolerances are derived from Test System uncertainties, regulatory requirements and criticality to system performance. As a result, the Test Tolerances may sometimes be set to zero.

The test tolerances should not be modified for any reason e.g. to take account of commonly known test system errors (such as mismatch, cable loss, etc.).

Note that a formula for applying Test Tolerances is provided for all tests, even those with a test tolerance of zero. This is necessary in the case where the Test System uncertainty is greater than that allowed in subclause 4.1.2. In this event, the excess error shall be subtracted from the defined test tolerance in order to generate the correct tightened test requirements as defined in this Annex.

## C.1 Measurement of transmitter

**Table C.1-1: Derivation of test requirements (Transmitter tests)**

Test	Minimum requirement in TS 37.104	Test Tolerance (TT)	Test requirement
6.2.1 Base Station maximum output power	UTRA and E-UTRA In normal conditions: within $\pm 2$ dB of manufacturer's rated output power	0.7 dB	Formula: Upper limit + TT, Lower limit - TT In normal conditions: within +2.7 dB and -2.7 dB of the manufacturer's rated output power
	In extreme conditions: within $\pm 2.5$ dB of manufacturer's rated output power	0.7 dB	In extreme conditions: within +3.2 dB and -3.2 dB of the manufacturer's rated output power
	GSM/EDGE In normal conditions: within $\pm 2$ dB of manufacturer's rated output power	1.0 dB	In normal conditions: within +3.0 dB and -3.0 dB of the manufacturer's rated output power
	In extreme conditions: within $\pm 2.5$ dB of manufacturer's rated output power	1.0 dB	In extreme conditions: within +3.5 dB and -3.5 dB of the manufacturer's rated output power
6.6.1.5.1 Transmitter spurious emissions, Mandatory Requirements	Maximum level defined in Table 6.6.1.1.1-1 of TS 37.104 [2].	0 dB	Formula: Minimum Requirement + TT
6.6.1.5.2 Transmitter spurious emissions, Mandatory Requirements	Maximum level defined in Table 6.6.1.1.2-1 of TS 37.104 [2].	0 dB	Formula: Minimum Requirement + TT
6.6.1.5.3 Transmitter spurious emissions, Additional BC2 Requirement	Maximum level defined in Table 6.6.1.1.3-1 of TS 37.104 [2].	0 dB	Formula: Minimum Requirement + TT
6.6.1.5.4 Transmitter spurious emissions, Protection of BS receiver	Maximum level defined in Table 6.6.1.2.1-1 of TS 37.104 [2].	0 dB	Formula: Minimum Requirement + TT
6.6.1.5.5 Transmitter spurious emissions, Additional spurious emission requirements	Maximum level defined in Tables 6.6.1.3.1-1 and 6.6.1.3.1-2 of TS 37.104 [2].	0 dB	Formula: Minimum Requirement + TT
6.6.1.5.6 Transmitter spurious emissions, Co-location	Maximum level defined in Table 6.6.1.4.1-1 of TS 37.104 [2].	0 dB	Formula: Minimum Requirement + TT

6.6.2 Operating band unwanted emissions	<p><u>For BC1 and BC2:</u></p> <p>Offset &lt; 1 MHz -14dBm/30kHz to -26dBm/30kHz</p> <p>1 MHz ≤ Offset &lt;10 MHz -13 dBm/1 MHz</p> <p>10 MHz ≤ Offsets -15 dBm/1 MHz</p> <p><u>For BC2 with adjacent GSM/EDGE or E-UTRA 1.4 and 3 MHz carriers:</u></p> <p>Offset &lt; 0.05 MHz 2 dBm/30kHz to 5 dBm/30 kHz</p> <p>0.05 MHz ≤ Offset -14 dBm/30kHz to 2 dBm/30 kHz</p>	<p>1.5 dB</p> <p>1.5 dB</p> <p>0 dB</p> <p>1.5 dB</p> <p>1.5 dB</p>	<p>Formula: Minimum requirement + TT</p> <p>-12.5 dBm/30kHz to -24.5 dBm/30kHz</p> <p>-11.5 dBm/1 MHz</p> <p>-15 dBm/1 MHz</p> <p>3.5 dBm/30kHz to 6.5 dBm/30 kHz</p> <p>-12.5 dBm/30kHz to 3.5 dBm/30 kHz</p>
6.6.3 Occupied bandwidth	<p><math>BW_{\text{Channel}}</math> for E-UTRA 5 MHz for UTRA FDD 1.6 MHz for UTRA TDD</p>	0 kHz	Formula: Minimum Requirement + TT
6.7 Transmitter intermodulation (interferer requirements) This tolerance applies to the stimulus and not the measurements defined in 6.6.1, 6.6.2 and 6.6.4.	Wanted signal level - interferer level = 30 dB	0 dB	<p>Formula: Ratio + TT</p> <p>Wanted signal level - interferer level = 30 + 0 dB</p>



## C.2 Measurement of receiver

Table C.2-1: Derivation of test requirements (Receiver tests)

Test	Minimum Requirement in TS 37.104	Test Tolerance (TT)	Test Requirement
7.4.5.1 In-band selectivity and blocking, General blocking requirement	Wanted Signal mean power = $P_{\text{REFSENS}} + x$ dB, where x is equal to 6 in case of E-UTRA or UTRA and equal to 3 in case of GSM/EDGE.  Interferer signal mean power: -40 dBm.	0 dB	Formula: Wanted signal power + TT.  Interferer signal power unchanged.
7.4.5.2 In-band selectivity and blocking, General narrowband blocking requirement	Wanted Signal mean power = $P_{\text{REFSENS}} + x$ dB, where x is equal to 6 in case of E-UTRA or UTRA and equal to 3 in case of GSM/EDGE.  Interferer signal mean power: -49 dBm.	0 dB	Formula: Wanted signal power + TT.  Interferer signal power unchanged.
7.4.5.5 In-band selectivity and blocking, Additional BC3 requirement	Wanted Signal mean power = $P_{\text{REFSENS}} + x$ dB, where x is equal to 6 in case of E-UTRA or UTRA.  Interferer signal mean power: -40 dBm.	0 dB	Formula: Wanted signal power + TT.  Interferer signal power unchanged.
7.5.5.1 Out-of-band blocking, General requirement	Wanted Signal mean power = $P_{\text{REFSENS}} + x$ dB, where x is equal to 6 in case of E-UTRA or UTRA and equal to 3 in case of GSM/EDGE.  Interferer signal mean power: -15 dBm.	0 dB	Formula: Wanted signal power + TT.  Interferer signal power unchanged.
7.5.5.2 Out-of-band blocking, Co-location	Wanted Signal mean power = $P_{\text{REFSENS}} + x$ dB, where x is equal to 6 in case of E-UTRA or UTRA and equal to 3 in case of GSM/EDGE.  Interferer signal mean power: +16 dBm.	0 dB	Formula: Wanted signal power + TT.  Interferer signal power unchanged.
7.6.5 Receiver spurious emissions	Maximum level defined in Tables 7.6.5.1-1 and 7.6.5.2-1 of TS 37.104 [2].	0 dB	Formula: Maximum level + TT
7.7.5.1 Receiver intermodulation, General requirement	Wanted Signal mean power = $P_{\text{REFSENS}} + x$ dB, where x is equal to 6 in case of E-UTRA or UTRA and equal to 3 in case of GSM/EDGE.  Interferer signal mean power: -48 dBm.	0 dB	Formula: Wanted signal mean power + TT.  CW interferer signal power unchanged.  Modulated interferer signal power unchanged.
7.7.5.2 Receiver intermodulation, General narrowband requirement	Wanted Signal mean power = $P_{\text{REFSENS}} + x$ dB, where x is equal to 6 in case of E-UTRA or UTRA and equal to 3 in case of GSM/EDGE.  Interferer signal mean power: -52 dBm.	0 dB	Formula: Wanted signal mean power + TT.  CW interferer signal power unchanged.  Modulated interferer signal power unchanged.

## Annex D (informative): Measurement system set-up

Example of measurement system set-ups are attached below as an informative annex.

### D.1 Transmitter

#### D.1.1 Base station output power, transmitter ON/OFF power, modulation quality, transmitter spurious emissions and operating band unwanted emissions

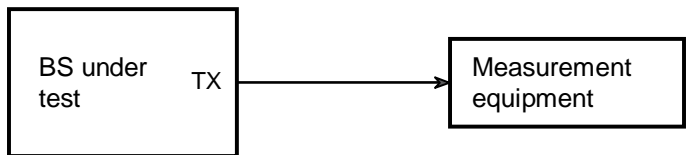

**Figure D.1-1: Measuring system set-up for base station output power, transmitter ON/OFF power, modulation quality, transmitter spurious emissions and operating band unwanted emissions**

#### D.1.2 Transmitter intermodulation

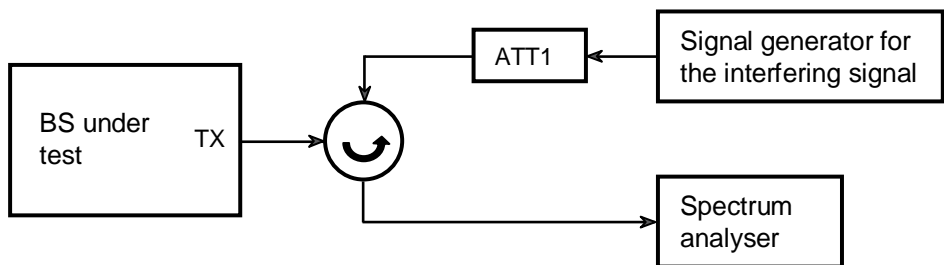

**Figure D.1-2: Measuring system set-up for transmitter intermodulation**

## D.2 Receiver

### D.2.1 Blocking characteristics

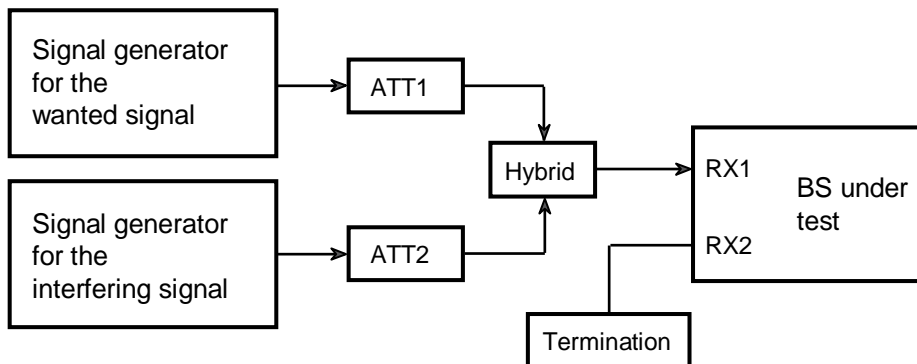

Figure D.2-1: Measuring system set-up for blocking characteristics

### D.2.2 Receiver spurious emissions

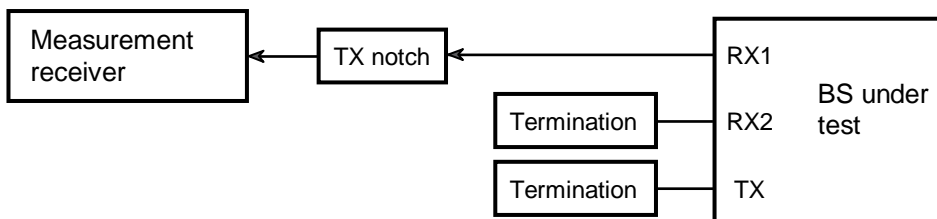

Figure D.2-2: Measuring system set-up for receiver spurious emissions

### D.2.3 Receiver intermodulation

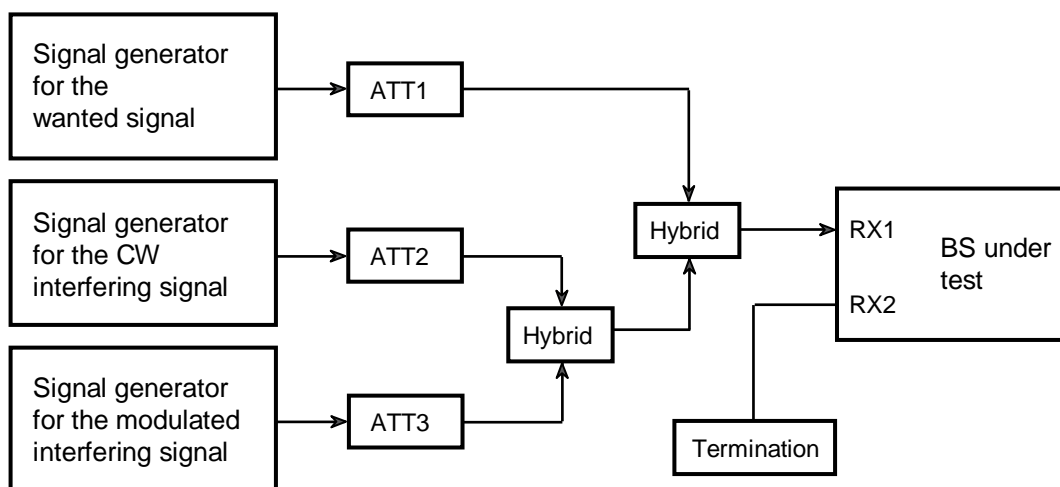

Figure D.2-3: Measuring system set-up for receiver intermodulation

## Annex E (informative): Change history

Change history							
Date	TSG #	TSG Doc.	CR	Rev	Subject/Comment	Old	New
2009-10	R4#52bis	R4-093772			Specification skeleton created from 3GPP TS template		0.0.1
2009-11	R4#53	R4-094778			Agreed Text Proposals in RAN4#53: <b>R4-094507</b> , "TP for TS 37.141 clause 2 and 3." <b>R4-094805</b> , "TP for TS 37.141 clause 4.11; BS Configurations." <b>R4-094871</b> , "TP for TS 37.141 clause 4.1, 4.2, 4.3, 4.4 and 4.5." <b>R4-094872</b> , "TP for TS 37.141 Annex C; Test Tolerances and derivation of test requirements."	0.0.1	0.1.0
2010-02	R4#54	R4-100579			Agreed Text Proposals in RAN4 AH#1: <b>R4-100026</b> , "TP for TS37.141: Format and interpretation of tests" <b>R4-100028</b> , "TP for TS37.141: Selection of configurations for testing" <b>R4-100241</b> , "TP for TS 37.141 clause 2, 3 and 4."	0.1.0	0.2.0
2010-02	R4#54	R4-100975			Agreed Text Proposals in RAN4#54: <b>R4-100405</b> , "TP for TS37.141: Manufacturers declarations of regional and optional requirements" <b>R4-100863</b> , "TP Manufacturers declaration of supported RF configurations for section 4.7" <b>R4-100986</b> , "TP for TS 37.141 clause 6.6.1; Transmitter spurious emissions" <b>R4-101036</b> , "TP MSR test configurations for section 4.8"	0.2.0	0.3.0
2010-04	R4#55	R4-101576			Agreed Text Proposals in RAN4 AH#2 and E-mail approved Text Proposals after RAN4 AH#2: <b>R4-101186</b> , "TP for TS 37.141 clause 6.6.4; Adjacent Channel Leakage power Ratio (ACLR)" <b>R4-101207</b> , "TP for manufacturers declaration, subclause 4.7.2" <b>R4-101208</b> , "TP TDD test configurations, subclause 4.8" <b>R4-101510</b> , "TP for requirements and test configuration applicability, subclause 5.1" <b>R4-101511</b> , "TP for requirements and test configuration applicability, subclause 5.2" <b>R4-101512</b> , "TP for capability set, subclause 4.7.1" <b>R4-101514</b> , "TP for update of Transmitter spurious emissions test in TS 37.141" <b>R4-101515</b> , "TP for TS 37.141 clause 6.7; Transmitter intermodulation" <b>R4-101520</b> , "Text proposal for 37.141 on B, M and T channels definition" <b>R4-101521</b> , "TP for TS 37.141, clause 7.2 MSR Receiver reference sensitivity level" <b>R4-101522</b> , "TP for TS 37.141 clause 7.3; Dynamic range" <b>R4-101523</b> , "TP for TS 37.141 clause 6.6.2; Operating band unwanted emissions" <b>R4-101524</b> , "TP for TS 37.141, clause 7.4 MSR Receiver in-band selectivity and blocking" <b>R4-101525</b> , "TP for TS 37.141, clause 7.5 MSR Receiver out-of-band-blocking" <b>R4-101526</b> , "TP for TS 37.141, clause 7.6 MSR Receiver spurious emissions" <b>R4-101527</b> , "TP for TS 37.141, clause 7.7 MSR Receiver intermodulation" <b>R4-101528</b> , "TP for TS 37.141, clause 7.8 MSR Receiver in-channel selectivity" <b>R4-101542</b> , "TP for TS 37.141 clause 6.6.3: Occupied bandwidth"	0.3.0	0.4.0
2010-05	R4#55	R4-102216			Agreed Text Proposals in RAN4#54: <b>R4-101882</b> , "TP for TS 37.141; Transmitter Test"	0.4.0	0.5.0

					<p>uncertainties"  <b>R4-101884</b>, "TP for TS 37.141; clause 4.4 Operating band update"  <b>R4-101885</b>, "TP for TS 37.141; Adding missing text in subclause 4.11.5 and 4.11.7"  <b>R4-102058</b>, "Corrections for subclause 4.1"  <b>R4-102059</b>, "Corrections for Annex C"  <b>R4-102060</b>, "Corrections for subclauses 4.9, 4.10"  <b>R4-102061</b>, "Corrections for subclauses 4.11, 4.12"  <b>R4-102062</b>, "Corrections for subclause 5"  <b>R4-102086</b>, "Corrections to clause 7.1"  <b>R4-102087</b>, "Corrections to clause 7.2"  <b>R4-102088</b>, "Corrections to clause 7.3"  <b>R4-102093</b>, "Corrections to clause 7.8"  <b>R4-102096</b>, "TS 37.141: TP for Co-existence with services in adjacent frequency bands"  <b>R4-102129</b>, "Spurious emissions limits and blocking requirements for coexistence with CDMA850"  <b>R4-102173</b>, "TP for TS 37.141; clause 4.3 Regional Requirements"  <b>R4-102245</b>, "TP for TS 37.141 clause 6.5.3; Time alignment between transmitter branches"  <b>R4-102249</b>, "Corrections to clause 7.4"  <b>R4-102250</b>, "Corrections to clause 7.5"  <b>R4-102251</b>, "Corrections to clause 7.6"  <b>R4-102252</b>, "Corrections to clause 7.7"  <b>R4-102273</b>, "TP for TS 37.141; Clause 6.2 BS output power"  <b>R4-102274</b>, "TP for Clause 4.9.2"  <b>R4-102275</b>, "Corrections for subclause 6.6.1"  <b>R4-102276</b>, "Corrections for subclause 6.6.2"  <b>R4-102277</b>, "Corrections for subclause 6.6.3"  <b>R4-102278</b>, "Corrections for subclause 6.6.4"  <b>R4-102282</b>, "Corrections for subclause 4.8"  <b>R4-102279</b>, "TP for TS 37.141; Clause 6.7 Tx IM clarification"</p>		
2010-06	RP#48	RP-100580			Presentation to TSG RAN plenary.	0.5.0	1.0.0
2010-06	RP#48	RP-100580			Approved by TSG RAN plenary.	1.0.0	9.0.0
2010-09	RP-49	RP-100923	002	1	Clarifications on Base Station transmit and receive configurations	9.0.0	9.1.0
2010-09	RP-49	RP-100923	003	2	Annex B: Environmental conditions	9.0.0	9.1.0
2010-09	RP-49	RP-100923	006		Adding transmitter test tolerances	9.0.0	9.1.0
2010-09	RP-49	RP-100923	008		Adding test System Uncertainty for transmitter spurious emission tests	9.0.0	9.1.0
2010-09	RP-49	RP-100923	009	1	Correction of the Ancillary RF Amplifiers references and references to Annex A, B and D	9.0.0	9.1.0
2010-09	RP-49	RP-100923	010		Update of the Transmitter characteristics General subclause	9.0.0	9.1.0
2010-09	RP-49	RP-100923	013	1	Adding Modulation quality and Frequency error test cases	9.0.0	9.1.0
2010-09	RP-49	RP-100923	014		Correction of the NOTEs in the transmitter intermodulation procedure	9.0.0	9.1.0
2010-09	RP-49	RP-100923	015		Characteristics of interfering signals	9.0.0	9.1.0
2010-09	RP-49	RP-100923	021	1	Test configuration and power allocation completion	9.0.0	9.1.0
2010-09	RP-49	RP-100923	023		TS 37.141 Clause 6.3; Output power dynamics	9.0.0	9.1.0
2010-09	RP-49	RP-100923	024		General corrections for the MSR test specification	9.0.0	9.1.0
2010-09	RP-49	RP-100923	025		Maximum Test system Uncertainty for Occupied bandwidth and Transmitter intermodulation	9.0.0	9.1.0
2010-09	RP-49	RP-100923	026	1	Adding test tolerances and test system uncertainty for receiver spurious emissions tests	9.0.0	9.1.0
2010-09	RP-49	RP-100923	027	1	Measurement set-ups for transmitter and receiver tests	9.0.0	9.1.0
2010-09	RP-49	RP-100923	028		Modification on testing of time mask of BC3 base station	9.0.0	9.1.0

---

# History

<b>Document history</b>		
V9.0.0	July 2010	Publication
V9.1.0	October 2010	Publication