

# ETSI TS 143 129 V6.1.0 (2005-01)

---

*Technical Specification*

**Digital cellular telecommunications system (Phase 2+);  
Packed-switched handover for GERAN A/Gb mode;  
Stage 2  
(3GPP TS 43.129 version 6.1.0 Release 6)**



---

**Reference**DTS/TSGG-0243129v610

---

**Keywords**GSM

---

**ETSI**

650 Route des Lucioles  
F-06921 Sophia Antipolis Cedex - FRANCE

---

Tel.: +33 4 92 94 42 00 Fax: +33 4 93 65 47 16

Siret N° 348 623 562 00017 - NAF 742 C  
Association à but non lucratif enregistrée à la  
Sous-Préfecture de Grasse (06) N° 7803/88

---

**Important notice**

---

Individual copies of the present document can be downloaded from:

<http://www.etsi.org>

The present document may be made available in more than one electronic version or in print. In any case of existing or perceived difference in contents between such versions, the reference version is the Portable Document Format (PDF). In case of dispute, the reference shall be the printing on ETSI printers of the PDF version kept on a specific network drive within ETSI Secretariat.

Users of the present document should be aware that the document may be subject to revision or change of status. Information on the current status of this and other ETSI documents is available at

<http://portal.etsi.org/tb/status/status.asp>

If you find errors in the present document, please send your comment to one of the following services:

[http://portal.etsi.org/chaicor/ETSI\\_support.asp](http://portal.etsi.org/chaicor/ETSI_support.asp)

---

**Copyright Notification**

---

No part may be reproduced except as authorized by written permission.  
The copyright and the foregoing restriction extend to reproduction in all media.

© European Telecommunications Standards Institute 2005.  
All rights reserved.

**DECT™**, **PLUGTESTS™** and **UMTS™** are Trade Marks of ETSI registered for the benefit of its Members.  
**TIPHON™** and the **TIPHON logo** are Trade Marks currently being registered by ETSI for the benefit of its Members.  
**3GPP™** is a Trade Mark of ETSI registered for the benefit of its Members and of the 3GPP Organizational Partners.

---

## Intellectual Property Rights

IPRs essential or potentially essential to the present document may have been declared to ETSI. The information pertaining to these essential IPRs, if any, is publicly available for **ETSI members and non-members**, and can be found in ETSI SR 000 314: *"Intellectual Property Rights (IPRs); Essential, or potentially Essential, IPRs notified to ETSI in respect of ETSI standards"*, which is available from the ETSI Secretariat. Latest updates are available on the ETSI Web server (<http://webapp.etsi.org/IPR/home.asp>).

Pursuant to the ETSI IPR Policy, no investigation, including IPR searches, has been carried out by ETSI. No guarantee can be given as to the existence of other IPRs not referenced in ETSI SR 000 314 (or the updates on the ETSI Web server) which are, or may be, or may become, essential to the present document.

---

## Foreword

This Technical Specification (TS) has been produced by ETSI 3rd Generation Partnership Project (3GPP).

The present document may refer to technical specifications or reports using their 3GPP identities, UMTS identities or GSM identities. These should be interpreted as being references to the corresponding ETSI deliverables.

The cross reference between GSM, UMTS, 3GPP and ETSI identities can be found under <http://webapp.etsi.org/key/queryform.asp>.

# Contents

Intellectual Property Rights .....	2
Foreword.....	2
Foreword.....	6
Introduction .....	6
1 Scope .....	7
2 References .....	7
3 Definitions and abbreviations.....	8
3.1 Definitions .....	8
3.2 Void.....	8
3.3 Abbreviations .....	8
4 Architecture and principles .....	10
4.1 Reference architecture .....	10
4.2 Handover principles .....	10
4.2.1 General.....	10
4.2.2 PS Handover preparation phase .....	11
4.2.3 PS Handover execution phase.....	11
4.2.4 PS Handover Network Node Responsibilities .....	12
4.3 Protocol architecture.....	12
4.3.1 User plane overview .....	12
4.3.2 Control plane overview.....	12
4.3.3 Physical Layer .....	13
4.3.3.1 Shared Channels.....	13
4.3.3.1.1 General .....	13
4.3.4 RLC/MAC .....	13
4.3.5 Radio Resource (RR).....	13
4.3.6 BSSGP .....	13
4.3.7 Overview of PS Handover Signalling Messages .....	14
4.3.7.1 PS handover signalling messages on the Um interface .....	14
4.3.7.2 PS handover signalling messages on the Gb interface .....	14
4.3.7.3 PS handover signalling messages on the Gn interface .....	15
4.4 Identifiers .....	15
4.4.1 NSAPI, PFI, RAB ID relation during inter-RAT, inter-mode PS handover .....	16
5 Signalling procedures.....	17
5.1 GERAN (A/Gb) → GERAN (A/Gb) handover.....	17
5.1.1 Intra Cell.....	17
5.1.2 Intra BSS.....	17
5.1.2.1 General .....	17
5.1.2.2 Intra BSS HO; Preparation phase.....	17
5.1.2.3 Intra BSS HO; Execution phase .....	18
5.1.2.4 Intra BSS Handover - Optimised .....	19
5.1.3 Intra SGSN.....	21
5.1.3.1 Intra SGSN/Inter BSS HO, Preparation phase .....	21
5.1.3.2 Intra SGSN/Inter BSS HO, Execution phase .....	22
5.1.4 Inter SGSN.....	24
5.1.4.1 Inter SGSN HO, Preparation phase .....	24
5.1.4.2 Inter SGSN HO, Execution phase .....	26
5.2 Inter-RAT/mode handover (GERAN A/Gb → UTRAN, GERAN Iu).....	30
5.2.1 Intra SGSN.....	30
5.2.1.1 Intra-SGSN GERAN A/Gb to UTRAN/GERAN Iu HO; Preparation phase .....	30
5.2.1.2 Intra-SGSN GERAN A/Gb to UTRAN/GERAN Iu HO; Execution phase .....	31
5.2.2 Inter SGSN.....	34
5.2.2.1 Inter-SGSN GERAN A/Gb to UTRAN/GERAN Iu HO; Preparation phase .....	34

5.2.2.2	Inter-SGSN GERAN A/Gb to UTRAN/GERAN Iu HO; Execution phase .....	36
5.3	Inter-RAT/mode Handover (UTRAN/GERAN Iu → GERAN A/Gb).....	40
5.3.1	Intra SGSN.....	40
5.3.1.1	Inter RAT/mode UTRAN/GERAN Iu to GERAN A/Gb PS HO; Preparation phase .....	40
5.3.1.2	Inter RAT/mode UTRAN/GERAN Iu to GERAN A/Gb PS HO; Execution phase.....	42
5.3.2	Inter SGSN.....	44
5.3.2.1	Inter RAT/mode UTRAN/GERAN Iu to GERAN A/Gb PS HO; Preparation phase .....	44
5.3.2.2	Inter RAT UTRAN/GERAN Iu to GERAN A/Gb PS HO; Execution phase .....	47
5.4	Handover reject .....	50
5.4.1	General.....	50
5.4.2	Inter-SGSN HO Reject; Signalling procedure .....	50
5.5	Handover cancel.....	50
5.5.1	General.....	50
5.5.2	Inter-RAT Cancellation; Signalling procedure .....	51
5.6	Container handling .....	51
5.6.1	Contents of the containers.....	52
5.6.1.1	Contents of the GERAN A/Gb mode → GERAN A/Gb Transparent Containers .....	52
5.6.1.1.1	Source BSS to Target BSS Transparent Container.....	52
5.6.1.1.2	Target BSS to Source BSS Transparent Container.....	53
5.6.1.2	Contents of the GERAN A/Gb mode → UTRAN Transparent Containers .....	53
5.6.1.2.1	Source RNC to Target RNC Transparent Container .....	53
5.6.1.2.2	Target RNC to Source RNC Transparent Container .....	53
5.6.1.3	Contents of the UTRAN → GERAN A/Gb Mode Transparent Containers.....	53
5.6.1.3.1	Source BSS to Target BSS Transparent Container.....	53
5.6.1.3.2	Target BSS to Source BSS Transparent Container.....	54
5.6.1.4	Contents of the GERAN A/Gb mode → GERAN Iu mode Transparent Containers .....	54
5.6.1.4.1	Source RNC to Target RNC Transparent Container .....	54
5.6.1.4.2	Target RNC to Source RNC Transparent Container .....	54
5.6.1.5	Content of GERAN Iu mode → GERAN A/Gb mode Transparent Containers .....	54
5.6.1.5.1	Source BSS to Target BSS Transparent Container.....	54
5.6.1.5.2	Target BSS to Source BSS Transparent Container.....	55
5.7	PS Handover Failure .....	55
5.7.1	Preparations Phase Failure Scenarios .....	55
5.7.1.1	PS Handover preparation phase failure scenarios on the Um interface.....	55
5.7.1.2	PS Handover preparation phase failure scenarios on the Gb interface.....	55
5.7.1.3	PS Handover preparation phase failure scenarios on the Gn interface.....	56
5.7.2	Execution Phase Failure Scenarios .....	56
5.7.2.1	Execution phase failures on the Um interface.....	56
5.7.2.2	Execution phase failures on the Gb interface.....	57
5.7.2.3	Execution phase failures on the Gn interface.....	57
6	Radio interface Signalling .....	57
6.1	PS Handover Signalling (Um).....	57
6.1.1	General.....	57
6.1.2	Overview of PS Handover messages .....	57
6.1.2.1	GERAN A/Gb mode to GERAN A/Gb mode PS Handover.....	57
6.1.2.2	UTRAN/GERAN Iu mode to GERAN A/Gb mode PS Handover.....	58
6.1.2.3	GERAN A/Gb mode to GERAN Iu mode PS Handover .....	59
6.1.2.4	GERAN A/Gb mode to UTRAN mode PS Handover.....	59
6.1.3	RLC/MAC segmentation .....	59
6.1.4	Inter RAT/mode PS Handover to GERAN A/Gb .....	59
6.1.5	Inter RAT/mode PS Handover from GERAN A/Gb.....	59
6.2	Mechanisms for Initial Access in the Target Cell .....	60
6.2.1	General.....	60
6.2.2	Synchronisation of cells.....	60
6.2.3	Option 1 - Downlink Data sent after performing access in the target cell .....	60
6.2.3.1	Unsynchronised Networks Call Flow.....	60
6.2.3.2	Synchronised Networks Call Flow.....	61
6.2.4	Option 2 - Downlink Data sent before performing access in the target cell (Blind Transmission) .....	62
6.2.4.1	Unsynchronised Networks Call Flow.....	62
6.2.4.2	Synchronised Network Call Flow .....	63
6.3	Methods for triggering PS Handover.....	63

**Annex A (normative):**      **Agreed handover principles** .....64  
A.1    Agreed handover principles.....64  
**Annex B (informative):**      **Change history** .....66  
History .....67

---

## Foreword

This Technical Specification has been produced by the 3<sup>rd</sup> Generation Partnership Project (3GPP).

The contents of the present document are subject to continuing work within the TSG and may change following formal TSG approval. Should the TSG modify the contents of the present document, it will be re-released by the TSG with an identifying change of release date and an increase in version number as follows:

Version x.y.z

where:

- x the first digit:
  - 1 presented to TSG for information;
  - 2 presented to TSG for approval;
  - 3 or greater indicates TSG approved document under change control.
- y the second digit is incremented for all changes of substance, i.e. technical enhancements, corrections, updates, etc.
- z the third digit is incremented when editorial only changes have been incorporated in the document.

---

## Introduction

In order to support packet based services with low latency requirements belonging for example to the Conversational QoS class in GERAN A/Gb mode packet switched handover is introduced. Packet switched handover reduces the service interruption of the user plane information at cell change compared to the cell-reselection. In addition PS handover enable methods to improve buffer handling of user plane data in order to reduce packet loss at cell-change.

---

# 1 Scope

The present document defines the stage-2 service description for packet switched handover in GERAN *A/Gb mode*. ITU-T Recommendation I.130 [8] describes a three-stage method for characterisation of telecommunication services, and ITU-T Recommendation Q.65 [9] defines stage 2 of the method. The present document refers to packet switched handover in GERAN *A/Gb mode*, and therefore focuses on the corresponding radio protocol enhancements to the packet switched domain only i.e. when services are provided through the Gb interface.

---

# 2 References

The following documents contain provisions which, through reference in this text, constitute provisions of the present document.

- References are either specific (identified by date of publication, edition number, version number, etc.) or non-specific.
- For a specific reference, subsequent revisions do not apply.
- For a non-specific reference, the latest version applies. In the case of a reference to a 3GPP document (including a GSM document), a non-specific reference implicitly refers to the latest version of that document *in the same Release as the present document*.

- [1] 3GPP TR 21.905: "Vocabulary for 3GPP Specifications".
- [2] 3GPP TS 22.105: "Services and service capabilities".
- [3] 3GPP TS 22.060: "General Packet Radio Service (GPRS); Service description; Stage 1".
- [4] 3GPP TS 43.064: "Overall description of the GPRS radio interface; Stage 2".
- [5] 3GPP TS 25.922: "Radio Resource Management strategies".
- [6] 3GPP TS 23.107: "Quality of Service (QoS) concept and architecture".
- [7] 3GPP TS 44.060: "General Packet Radio Service (GPRS); Mobile Station (MS) - Base Station System (BSS) interface; Radio Link Control/Medium Access Control (RLC/MAC) protocol".
- [8] ITU-T Recommendations I.130: "Method for the characterization of telecommunication services supported by an ISDN and network capabilities of an ISDN".
- [9] ITU-T Recommendation Q.65: "The unified functional methodology for the characterization of services and network capabilities".
- [10] 3GPP TS 48.018: "General Packet Radio Service (GPRS); Base Station System (BSS) - Serving GPRS Support Node (SGSN); BSS GPRS Protocol".
- [11] 3GPP TS 29.060: "General Packet Radio Service (GPRS); GPRS Tunnelling Protocol (GTP) across the Gn and Gp interface".
- [12] 3GPP TS 23.003: "Numbering, addressing and identification".
- [13] 3GPP TS 25.401: "UTRAN overall description".
- [14] 3GPP TS 43.051: "GSM/EDGE Radio Access Network (GERAN) overall description; Stage 2".
- [15] 3GPP TS 24.008: "Mobile radio interface Layer 3 specification; Core network protocols; Stage 3".
- [16] 3GPP TS 44.118: "Mobile radio interface layer 3 specification, Radio Resource Control (RRC) protocol; Iu mode".
- [17] 3GPP TS 25.331: "Radio Resource Control (RRC) protocol specification".



- [18] 3GPP TS 24.007: "Mobile radio interface signalling layer 3; General Aspects".
- [19] 3GPP TS 23.060: "General Packet Radio Service (GPRS); Service description; Stage 2".
- [20] 3GPP TS 23.108: "Mobile radio interface layer 3 specification core network protocols; Stage 2 (structured procedures)".
- [21] 3GPP TS 44.064: "Mobile Station - Serving GPRS Support Node (MS-SGSN) Logical Link Control (LLC) Layer Specification".
- [22] 3GPP TS 23.236: "Intra-domain connection of Radio Access Network (RAN) nodes to multiple Core Network (CN) nodes".
- [23] 3GPP TS 25.413: "UTRAN Iu interface Radio Access Network Application Part (RANAP) signalling".
- [24] 3GPP TS 43.129: "Packed-switched handover for GERAN A/Gb mode; Stage 2".
- [25] 3GPP TS 44.018: "Mobile radio interface layer 3 specification; Radio Resource Control (RRC) protocol".
- [26] 3GPP TS 45.010: "Radio subsystem synchronization".

---

## 3 Definitions and abbreviations

### 3.1 Definitions

For the purposes of the present document, the terms and definitions given in 3GPP TR 21.905 [1] and the following apply:

**A/Gb mode:** mode of operation of the MS when connected to the Core Network via GERAN and the A and/or Gb interfaces

**PFC subject to handover:** refers to a PFC that is supported using packet switched handover, e.g. a PFC with conversational QoS class

Whether a PFC needs handover or not is decided by the BSS. This decision criteria is not be standardized.

### 3.2 Void

### 3.3 Abbreviations

For the purposes of the present document, the following abbreviations apply:

ATM	Asynchronous Transfer Mode
BSC	Base Station Controller
BSS	Base Station Sub-system
BSSGP	Base Station Subsystem GPRS Protocol
BTS	Base Transceiver Station
CN part	Core Network part
CN	Core Network
CS	Circuit Switched
DTM	Dual Transfer Mode
EDGE	Enhanced Data rates for GSM Evolution
FLO	Flexible Layer One
GboIP	Gb over IP
GERAN	GSM/EDGE Radio Access Network
GPRS	General Packet Radio Service
GSM	Global System for Mobile communications
GTP	GPRS Tunnelling Protocol

IMS	IP Multimedia Subsystem
IP	Internet Protocol
LLC	Logical Link Control
MAC	Medium Access Control
MS	Mobile Station
MSC	Mobile Switching Centre
MTU	Maximum Transfer Unit
PDP	Packet Data Protocol
PDTCH	Packet Data Traffic CHannel
PFC	Packet Flow Context
PFM	Packet Flow Management
PS	Packet Switched
PTCCH	Packet Timing advance Control CHannel
QoS	Quality of Service
RAB	Radio Access Bearer
RAN	Radio Access Network
RAT	Radio Access Technology
RAU	Routeing Area Update
RLC	Radio Link Control
RN part	Radio Network part
RNC	Radio Network Controller
ROHC	RObust Header Compression
RRM	Radio Resource Management
RTP	Real Time Protocol
SABM	Set Asynchronous Balanced Mode
SACCH	Standalone Associated Control CHannel
SAPI	Service Access Point Identifier
SGSN	Serving GPRS Support Node
SIP	Session Initiated Protocol
SNDCP	Sub-Network Dependent Convergence Protocol
TBF	Temporary Block Flow
TF	Transport Format
TFC	Transport Format Combination
TFCI	Transport Format Combination Indicator
TR	Technical Report
TS	Technical Specification
UA	Unnumbered Acknowledgement
UDP	User Datagram Protocol
UE	User Equipment
UMTS	Universal Mobile Telephony System
UTRAN	UMTS Terrestrial Radio Access Network
VoIP	Voice over IP
XID	eXchange IDentification

## 4 Architecture and principles

### 4.1 Reference architecture

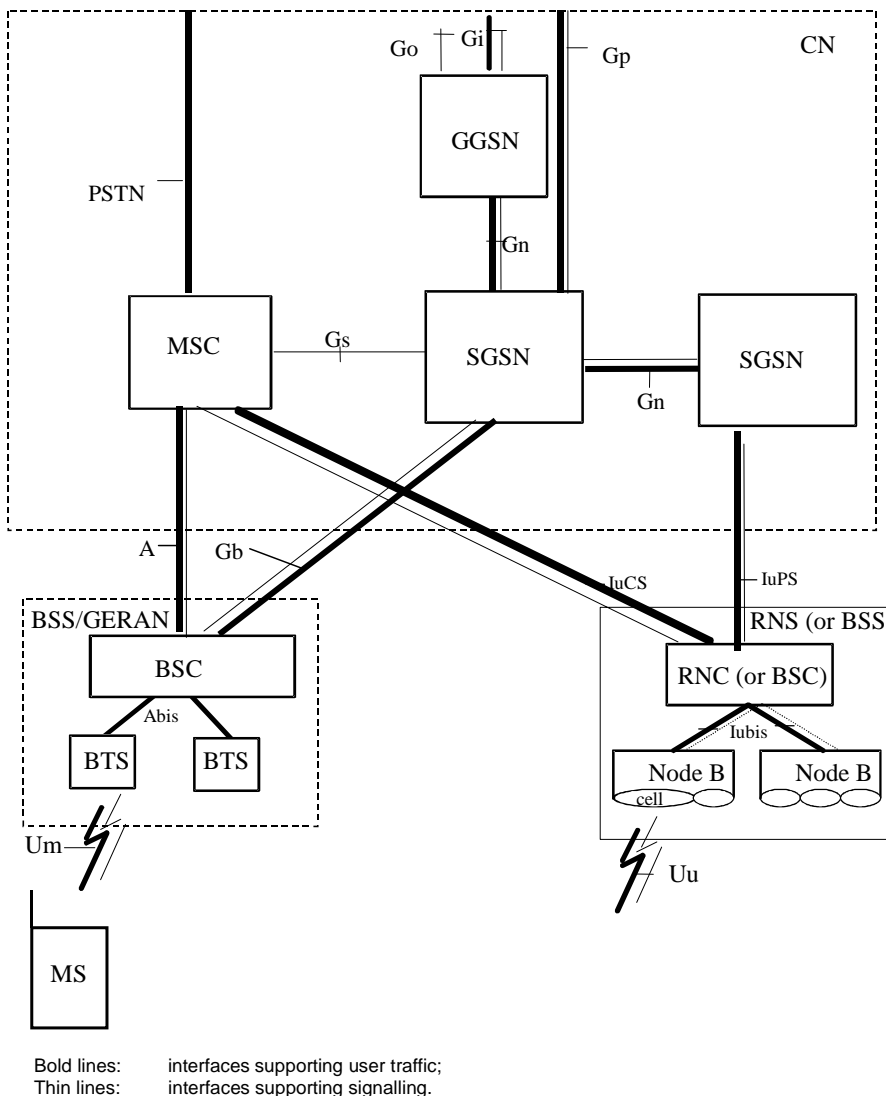

NOTE: The Iu interface is also supported by a GERAN BSS supporting Iu mode.

**Figure 1: Reference Architecture for PS handover in GERAN A/Gb mode**

## 4.2 Handover principles

### 4.2.1 General

The PS Handover procedure is used to handover an MS with one or more packet flows from a source cell to a target cell. The source and target cells can be located within either the same BSS (Intra BSS HO), different BSSs within the same SGSN (Intra SGSN HO) or belonging to different SGSNs (Inter SGSN HO), or systems with different radio access types (Inter RAT HO, Inter mode HO).

While the MS is still in the source cell:

- Radio resources in the target cell are allocated and signalled to the MS.
- System information of the target cell is signalled to the MS.

For each scenario (Intra BSS HO, Intra SGSN HO, Inter SGSN HO and Inter RAT/mode HO) the PS handover procedure is divided into:

- a preparation phase; and
- an execution phase.

By using the Gs interface (together with NMO1) the interruption time for the PS Handover procedure would be shortened since using a combined LAU/RAU procedure would be possible.

## 4.2.2 PS Handover preparation phase

The PS handover preparation phase consists of the following consecutive steps:

- the decision by the source BSS to request a PS handover for an MS with one or more PFCs subject to handover:
  - the request from the source BSS to the old SGSN for the PS handover;
  - if the target BSS is not connected to the same SGSN the request from the old SGSN to the new SGSN to reserve resources;
- the reservation of resources in the target network nodes prior to ordering the MS to move to the target cell. This involves:
  - in case of Inter SGSN handover, the new SGSN reserving SNDCP/LLC resources and Packet Flow Contexts;
  - in case of RA change the SGSN (which belongs to the RA) allocates a new P-TMSI and derives a new Local TLLI from this P-TMSI;
  - the target BSS reserving/allocating radio resources and Packet Flow Contexts in the target cell.

When handover has to be performed for an MS with multiple active PFCs, the SGSN requests the BSS to create one or more PFCs. If not all PFCs can be created successfully the target BSS indicates this to the new SGSN, which may then abort the handover. If no PFC can be created successfully the handover shall be aborted.

The target BSS may or may not establish radio resources for the created PFCs. PFCs with no radio resources reserved will be re-established upon arrival in the target cell. If no radio resources at all are established the handover shall be aborted.

## 4.2.3 PS Handover execution phase

The PS Handover execution phase consists of the following consecutive steps:

- packet forwarding by the old SGSN of the received DL packets both to the source BSS, new SGSN (if Inter SGSN HO) and the target BSS as soon as radio resources are reserved in the target BSS;
- the optional "blind" transmission by the target BSS of the DL RLC/MAC blocks over the reserved radio resources in the target cell is only valid for lossy type of services where unacknowledged LLC and RLC protocol modes are used;
- the command generated by the target BSS/RNS sent via the source BSS to order the MS to handover to the target cell;
- the notification by the MS of its presence in the target cell on the allocated radio resources;
- the redirection by the SGSN of the DL packets to the target BSS alone;
- the release of the resources on the source side including PFCs and radio resources.

### 4.2.4 PS Handover Network Node Responsibilities

This clause would reflect the Agreed Handover principles from the clause A.1 by listing the specific node responsibilities during PS handover.

## 4.3 Protocol architecture

This clause will contain information on the services and functions provided and required by each layer.

### 4.3.1 User plane overview

The user plane protocol architecture for GERAN A/Gb are depicted in figure 2.

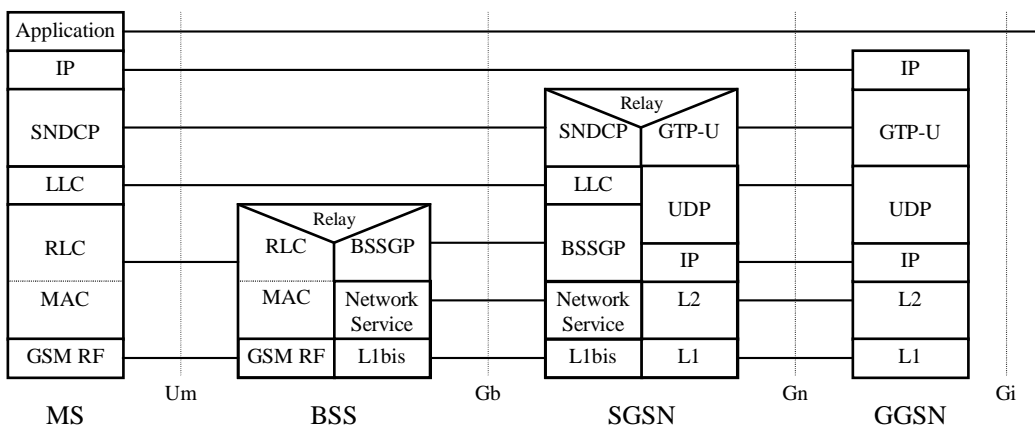

Figure 2: User Plane protocol architecture in A/Gb mode

### 4.3.2 Control plane overview

Figure 3 shows the protocol architecture for the control plane required to support PS Handover in A/Gb mode. Protocol entities on the network side under BSSGP are not shown, as the architecture remains the same as for the legacy A/Gb mode.

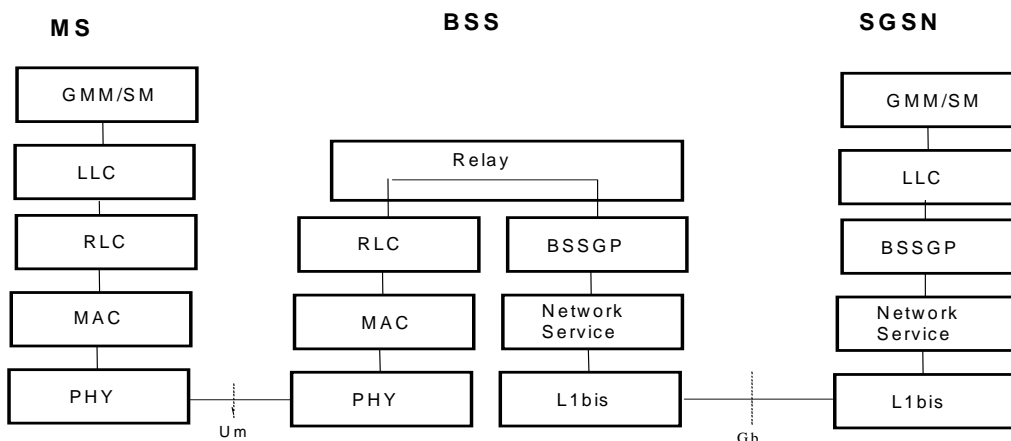

Figure 3: Control Plane Architecture in A/Gb mode

### 4.3.3 Physical Layer

#### 4.3.3.1 Shared Channels

##### 4.3.3.1.1 General

Radio resources on one or more shared channels may be assigned to an MS (according to its multislot capabilities) for exchange of user plane payload for any PFC between the BSS and the MS. The key characteristics of a service realized using a shared channel are as follows:

- RLC/MAC control messages are used to allocate the required uplink and downlink TBFs where both TBFs are associated with the same PFC and therefore are identified using the same PFI.
- Handover initiation decisions are made by the BSS and may be based on measurement reports or cell change notification information sent by the mobile station on PACCH.
- If the mobile station is allocated one or more shared channels in support of a PFC that is subject to handover, then the BSS may prohibit this MS from making autonomous cell re-selection decisions while that PFC is active.
- After the MS has moved to the target cell, initial uplink access in this cell is controlled by USF scheduling.

### 4.3.4 RLC/MAC

The services required from the RLC/MAC layer are:

- Data transfer in acknowledged mode.
- Data transfer in unacknowledged mode.
- Segmentation and reassembly.
- In-Sequence delivery of LLC PDUs (for a given PFC).
- Assignment, reconfiguration and release of TBFs and RLC instances (RLC/MAC control functions).
- Control of timing advance.
- Notification of unrecoverable errors to LLC.
- Handling of RLC/MAC control messages.

RLC/MAC services are required by radio resource management functions in order to send and receive messages to/from the MS and BSS relating to radio resource management.

RLC/MAC supports the following radio resource management features that are required for PS handover:

- Establishment of a TBF on one or more physical channel(s) in a given direction, for a given PFC.
- Reconfiguration of the radio resources assigned to one or more TBFs in downlink and/or uplink within a cell.
- Release of TBFs and associated radio resources following the corresponding service deactivation.
- Release of all TBFs and associated radio resources in the source cell, as a result of handover to a target cell.

### 4.3.5 Radio Resource (RR)

This clause will contain information on any impacts on the RR protocol related to support of PS Handover.

### 4.3.6 BSSGP

BSSGP is expected to provide the signalling channel for PS Handover related signalling between the CN and the BSS.

The services required from the BSSGP layer can therefore be summarised as:

- Transmission and reception of PS Handover related messages (i.e. PFM messages) over the Gb interface.
- Routing of PS Handover related messages to the PFM entity.
- Handling of PS Handover related messages with the appropriate priority.

### 4.3.7 Overview of PS Handover Signalling Messages

The signalling messages used during PS handover are divided into three groups depending on the utilized interface:

- PS handover signalling messages on the *Um* interface are RLC/MAC signalling blocks.
- PS handover signalling messages on the *Gb* interface are BSSGP signalling messages sent by the PFM entity.
- PS handover signalling messages on the *Gn* interface are GTP signalling messages.

#### 4.3.7.1 PS handover signalling messages on the Um interface

The signalling messages used on the *Um* interface are:

- PS Handover Command (BSS -> MS).

NOTE 1: The existing Packet Cell Change Order (PCCO) message enhanced with the PS Handover related IE is a suitable message to be used as PS handover Command.

- Packet Control Acknowledgement (MS -> BSS).
- Packet Control Acknowledgement - Access Bursts (MS -> BSS).
- Packet Uplink Assignment (BSS -> MS).
- Packet (P)SI Status (MS -> BSS).

NOTE 2: The signalling messages listed above are existing RLC/MAC signalling messages specified in 3GPP TS 44.060 [7].

#### 4.3.7.2 PS handover signalling messages on the Gb interface

The Gb interface signalling messages are new signalling messages carried by the BSSGP. These signalling messages are to be defined in 3GPP TS 48.018 [10].

The signalling messages used on the *Gb* interface are:

- PS Handover Required (BSS->CN):
  - This message is sent from the BSS to the SGSN to indicate that for a given MS which already has radio resource(s) assigned, a PS handover is required.
- PS Handover Request (CN->BSS):
  - This message is sent from the SGSN to the target BSS to request the target BSS to reserve resources for the MS subject to PS Handover.
- PS Handover Request Acknowledge (BSS->CN):
  - This message is sent from the target BSS to the SGSN to report the outcome of the resource allocation for the requested BSS PFCs.
- PS Handover Reject (BSS -> CN):
  - This message is sent from the target BSS to the SGSN to report the failure of the resource allocation for the requested BSS PFCs.

- PS Handover Complete (BSS->CN):
  - This message is sent from the target BSS to the SGSN to notify the MS of a successful access on the target cell.
- PS Handover Command (CN->BSS):
  - This message is sent from the SGSN to the source BSS to indicate that the MS can switch to the target cell.
- PS Handover Cancel (BSS->CN):
  - This message is sent from the BSS to the SGSN to inform the SGSN to abort an ongoing handover.
- PS Handover Required Reject (CN->BSS):
  - This message is sent from the SGSN to the BSS to inform unsuccessful resource allocation in the target cell.

### 4.3.7.3 PS handover signalling messages on the Gn interface

The Gn interface signalling messages are existing messages that will be used as described in 3GPP TS 29.060 [11].

The signalling messages used on the on the Gn interface between source SGSN and target SGSN are:

- Forward Relocation Request:
  - The old SGSN shall send a Forward Relocation Request message to the new SGSN to convey necessary information to perform the PS handover procedure between new SGSN and Target BSS.
- Forward Relocation Response:
  - The new SGSN shall send a Forward Relocation Response message to the old SGSN as a response to a previous Forward Relocation Request message.
- Forward Relocation Complete:
  - The new SGSN shall send a Forward Relocation Complete message to the old SGSN to indicate that the PS Handover procedure has been successfully finished.
- Forward Relocation Complete Acknowledge:
  - The old SGSN sends a Forward Relocation Complete Acknowledge message to the new SGSN as a response to Forward Relocation Complete message.
- Relocation Cancel Request:
  - The Relocation Cancel Request message is sent from the old SGSN to the new SGSN when the old SGSN is requested to cancel the PS Handover procedure by the source BSS by means of BSSGP message.
- Relocation Cancel Response:
  - The Relocation Cancel Response message is sent from the new SGSN to the old SGSN when the PS handover procedure has been cancelled in the old SGSN. This message is used as the response to the Relocation Cancel Request message.

GTP messages need to be enhanced with additional IE to support PS Handover.

## 4.4 Identifiers

The identifiers used in PS handover for GERAN A/Gb mode are the identities used by MS to connect via GERAN through the Gb interface as well as through the Iu interface to the Core Network.

A large number of these identities for GERAN A/Gb mode will be utilized in the PS handover procedure in GERAN A/Gb mode in the same manner as specified currently. However in order to support PS handover procedure new identifiers will be defined as well.



In order to enable data transmission and to address the resources allocated by the target system during the PS Handover procedure (i.e. for the case where the target cell belongs to another RA), before the MS moves to the target cell a new P-TMSI will be allocated by the SGSN associated with the RA the target cell belongs to. The new P-TMSI is a temporary and unique identifier in the new RA and is used to assign a local TLLI for the target cell.

NOTE: Further in this TS the term "local TLLI" refers to the Local TLLI derived from new P-TMSI assigned by the new SGSN and utilized in the target cell, whereas the term "old TLLI" refers to the Local TLLI utilized in the source cell that is derived from the P-TMSI assigned by the old SGSN.

In case of inter RAT PS Handover to/from UTRAN and inter-mode handover to/from GERAN Iu mode, existing UTRAN and GERAN Iu mode identifiers will be used.

The existing as well as new identifiers utilized in PS handover procedure for GERAN A/Gb mode are listed in table 1.

**Table 1: Identifiers utilized in PS handover in GERAN /AGb**

Identifier	Specification reference
CI (Cell Identity)	3GPP TS 23.003 [12], 3GPP TS 25.401 [13], 3GPP TS 43.051 [14]
RAI (Routing Area Identity)	3GPP TS 23.003 [12]
LAI (Location Area Identity)	3GPP TS 24.008 [15]
IMSI (International Mobile Subscriber Identity)	3GPP TS 23.003 [12]
P-TMSI (Packet Temporary Mobile Subscriber Identity)	3GPP TS 23.003 [12]
TLLI (Temporary Logical Link Identity)	3GPP TS 23.003 [12]
RNTI(Radio Network Temporary Identity)	3GPP TS 44.118 [16], 3GPP TS 25.401 [13]
GRNTI (GERAN Radio Network Temporary Identity)	3GPP TS 25.401 [13]
U-RNTI (UTRAN-RNTI)	3GPP TS 25.401 [13]
TEID (Tunnel Endpoint Identifier)	3GPP TS 29.060 [11]
NSAPI (Network Service Access Point Identifier)	3GPP TS 29.060 [11]
TI (Transaction Identifier)	3GPP TS 24.007 [18]
SAPI (Service Access Point Identifier)	3GPP TS 29.060 [11]
PFI (Packet Flow Identifier)	3GPP TS 48.018 [10]
BVCI (BSSGP Virtual Connection Identifier)	3GPP TS 48.018 [10]
RAB Id (Radio Access Bearer Identifier)	3GPP TS 25.331 [17]
RB Id (Radio Bearer Identifier)	3GPP TS 25.331 [17]
TFI (Temporary Flow Identity)	3GPP TS 44.060 [7]
USF (Uplink State Flag)	3GPP TS 44.060 [7]
PS handover Reference	Existing 3GPP TS 44.018 [10]/ To be Specified

The description of the new identifier is given below:

- PS Handover Reference.

PS Handover Reference is equivalent to handover reference in GSM, which is needed during PS Handover in GERAN A/Gb mode for reliability in order to prevent BSS overhearing other MSs access bursts, so as to identify the MS accessing the assigned resources. Handover Reference in GSM can be used as PS handover Reference (3GPP TS 44.018 [10]) during PS handover procedure or optionally PS handover reference can be defined specifically for PS handover procedure.

#### 4.4.1 NSAPI, PFI, RAB ID relation during inter-RAT, inter-mode PS handover

During the inter-RAT and inter-mode PS handover to/from UTRAN/GERAN Iu there is a need to associate the MSs active PDP context with the BSS PFC and RABs in the respective SGSN(s).

As depicted in 3GPP TS 23.060 [19] NSAPI is a common identifier of the PDP context in all systems and as such it can be used by the MS to associate the active PDP contexts to the BSS PFC identified by the PFI and the RAB identified by the RAB Id during the inter-mode and inter-RAT PS handover. The MS has to associate the BSS PFC identified by the PFI utilized in GERAN A/Gb mode cell with a RAB identified by RAB Id utilized in the UTRAN /GERAN Iu mode cell. This is done through the relation with the NSAPI, which is the common identifier in both systems. MS performs this association based on the identifiers received by the network.

The information received by the MS/UE depends on the RAT of the target cell. In case of the GERAN Iu mode target cell and GERAN A/Gb mode source cell, the MS shall receive the RAB Id and associate this with its existing PFIs based on the relation with NSAPI. In case of the GERAN A/Gb mode target cell, GERAN Iu mode source cell, the UE shall receive the PFI for each of the accepted NSAPIs and may receive the NSAPI / SAPI / PFI association for the case when the old SGSN did not have these values available and the new SGSN has assigned new values. The MS shall associate its RAB Ids to the respective SAPI and PFI based on the relation with NSAPI.

## 5 Signalling procedures

The signalling procedures will be updated once the Um signalling messages has been agreed.

### 5.1 GERAN (A/Gb) → GERAN (A/Gb) handover

#### 5.1.1 Intra Cell

Intra Cell PS Handover will be needed in cases when a new channel is selected in the same cell to be used by the MS. This is handled by the BSS internally and if there are no changes in the new channel there is no need for BSS to notify the SGSN about the change of channel.

BSS/SGSN signalling will be needed in case the new channel has limited resources and cannot support the same QoS, for the BSS PFC as the old channel.

For these purpose existing modification procedures on the Um and Gb interface are used, e.g. PACKET TIMESLOT RECONFIGURE (3GPP TS 44.060 [7]) on the air interface and MODIFY BSS PFC (3GPP TS 48.018 [10]) procedure on the Gb interface.

If the modification procedures fail BSS may cancel the intra cell PS handover procedure.

#### 5.1.2 Intra BSS

##### 5.1.2.1 General

This clause is further split into two clauses. The first describes an intra-BSS handover procedure based largely on the inter-BSS handover procedure. The second section describes an optional optimised intra-BSS handover procedure. When the source and target cells are within the same BSS the handover can be either executed by the BSS itself (optimised handover) or by involving the SGSN. In the latter case although handover is performed within one BSS the roles of source BSS and target BSS are the same as in Inter BSS Handover.

##### 5.1.2.2 Intra BSS HO; Preparation phase

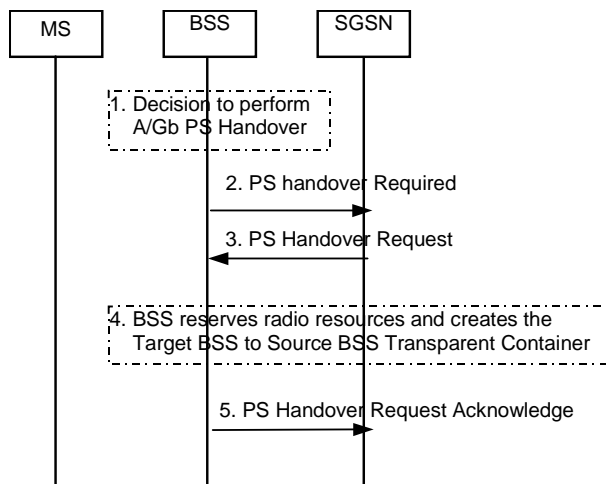

Figure 4: PS Handover Preparation Phase; Intra-BSS case (GERAN A/Gb → GERAN A/Gb)

1. The BSS decides to initiate a PS handover. At this point both uplink and downlink user data is transmitted via the following: TBFs between the MS and BSS, BSSGP PFCs tunnel(s) between the BSS and SGSN, GTP tunnel(s) between the SGSN and GGSN.
2. The BSS sends a **PS Handover Required** (TLLI, Cause, Source Cell Identifier, Target Cell Identifier, Source BSS to Target BSS Transparent Container [RN part]) message to the SGSN.
3. The SGSN determines from the Target ID the type of handover, i.e. intra-SGSN, inter-SGSN or inter-RAT/mode handover. In case of Intra-SGSN PS handover, the SGSN sends a **PS Handover Request** (TLLI, Cause, IMSI, Source Cell Identifier, Target Cell Identifier, PFCs To Be Set Up List, Source BSS to Target BSS Transparent Container [RN part]) message to the BSS. The SGSN shall not request resources for PFCs associated with PDP contexts with a maximum bit rate for uplink and downlink of 0 kbit/s.

NOTE: The BSS PFCs required to be set up are downloaded to the target BSS from the SGSN, i.e. all information required for PFC creation.

4. Based upon the ABQP for each PFC the BSS makes a decision about which PFCs to assign radio resources. The algorithm by which the BSS decides which PFCs that need resources is implementation specific. Due to resource limitations not all downloaded PFCs will necessarily receive resource allocation. The BSS allocates TBFs for each PFC that can be accommodated.

After allocating radio resources the target BSS shall prepare the Target BSS to Source BSS Transparent Container for the set up BSS PFCs.

5. The BSS shall send the **PS Handover Request Acknowledge** (TLLI, Cause, PFCs Set Up/Failed to Set Up, Target BSS to Source BSS Transparent Container [RN part, CN part]) message to the SGSN for the accepted PFCs. Upon sending the **PS Handover Request Acknowledge** message the BSS shall be prepared to receive downlink LLC PDUs directed to the new cell and associated with the accepted PFCs.

When the SGSN receives the **PS Handover Request Acknowledge** message and it decides to proceed with the handover, the preparation phase is finished and the execution phase will follow.

### 5.1.2.3 Intra BSS HO; Execution phase

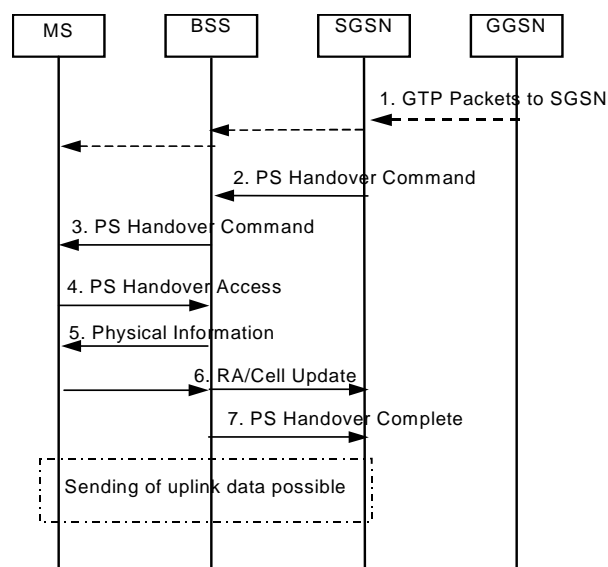

Figure 5: PS Handover Execution Phase; Intra-BSS case (GERAN A/Gb → GERAN A/Gb)

1. The SGSN continues to receive GTP packets from the GGSN (via GTP) and forwards the associated PDU payload to the MS via the BSS.

When receiving the **PS Handover Request Acknowledge** message the SGSN may, based on QoS, start duplication of LLC PDUs and forward those to the new cell in the BSS. If the SGSN forwards downlink packets to the new cell in the BSS, the BSS may start blind transmission of downlink user data towards the MS over the allocated radio channels.

2. The SGSN continues the PS Handover by sending a **PS Handover Command** (TLLI, Cause, PFCs To Be Set Up List, Target BSS to Source BSS Transparent Container [RN part, CN part]) message to the source BSS.

Before sending the **PS Handover Command** message, the SGSN based on QoS, suspends downlink data transfer for PDP contexts, which are sensitive to packet loss.

Before sending the **PS Handover Command** message to the MS the BSS, based on QoS, tries to empty the downlink BSS buffer for BSS PFCs, which are sensitive to packet loss.

The BSS receiving the **PS Handover Command** message stops the uplink traffic, based on QoS, for flows, which require delivery order to be preserved.

NOTE 1: Only PFI(s) for PFCs accepted by the target cell are included in the message.

3. The BSS sends the **PS Handover Command** (Handover Reference, Target BSS to Source BSS Transparent Container [RN part, CN part]) message to the MS by interrupting the transmission of LLC PDUs on any of the downlink TBFs. Following the transmission of this signalling message the BSS immediately resumes LLC PDU transmission until it either has no more LLC PDUs to send or the PFC is released. MS management of uplink N-PDUs following the reception of the **PS Handover Command** message is as follows:
  - All uplink packets associated with a PFC receiving handover treatment that have not yet been fully transmitted might be buffered depending on the QoS class.
  - Subsequent uplink packets that become available for transmission following the reception of the **PS Handover Command** message might also be buffered depending on the QoS class.
  - The MS may discard uplink packets during the link interruption to preserve the real-time properties.
4. The MS tunes to the radio channel and the timeslot allocated in the target cell by the BSS and sends the **PS Handover Access** (Handover Reference) message in the form of four handover access bursts to the BSS on the allocated channel. The **PS Handover Command** message may indicate that the **PS Handover Access** message is optional to send by the MS.
5. The BSS sends a **Physical information** message (see 3GPP TS 23.108 [20]) to the MS for the MS to synchronize.

NOTE 2: In the synchronised networks case the MS receives the timing advance information to use in uplink in the target cell in the **PS Handover Command** message. In this case the sending of the **Physical information** message in the target cell is omitted.

6. In case the target cell is within the same routing area as the source cell, the MS sends an arbitrary LLC frame to the SGSN, which in the SGSN is interpreted as an implicit cell update. In case the target cell is within another routing area, the MS sends a **Routing Area Update Request** message to the SGSN. To make the handover interruption short the MS sends this message immediately after receiving the **Physical Information** message or, in the synchronised network case, immediately after the sending of the **PS Handover Access** message.
7. Upon reception of the first correct RLC/MAC block (sent in normal burst format) from the MS the BSS sends a **PS Handover Complete** (TLLI, Handover Complete Status) message to inform the PFM entity in the SGSN that the MS has arrived in the target cell. The source BSS initiates the release of the radio resources in the source cell. After the reception of the **PS Handover Complete** message the SGSN shall be prepared to receive data from the new cell.

#### 5.1.2.4 Intra BSS Handover - Optimised

This clause describes the optimised intra-BSS PS handover procedures applicable for the case where the source and target cells are associated with the same Network Service Entity (NSE) and the same Routing Area (RA). The optimisation involves the BSS providing the data forwarding function and does not require any explicit signalling with the SGSN. Support for this procedure is optional for the BSS.

Supporting this procedure requires that the BSS be able to determine whether or not it manages PS resources for the target cell, whether or not the target cell is associated with the same NSE, that it can internally forward LLC PDUs from the source to the target cell and whether or not both cells are part of the same RA (i.e. the SGSN is not required to make this determination and relay this information). If the BSS cannot make these determinations it shall use the non-optimised intra-BSS PS handover procedures described in clauses 5.1.2.2 and 5.1.2.3.

NOTE: Since the transfer of LLC PDUs at PS handover are performed within the same BSS, the Source BSS to Target BSS Transparent Container and the Target BSS to Source BSS Transparent Container are not created in this scenario.

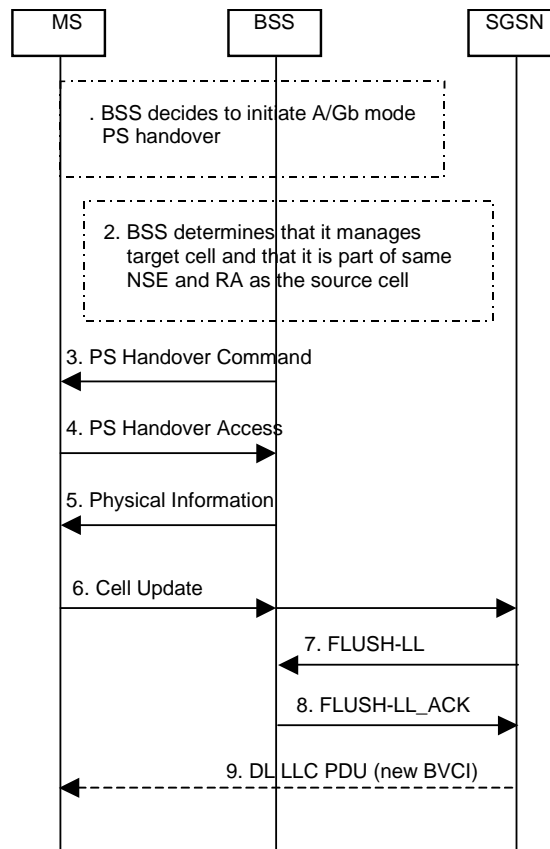

**Figure 6: Optimised Intra-BSS PS Handover (same NSE and same RA)**

1. The BSS decides that a handover is required based on received measurement reports.
2. The BSS determines that it manages resources for both cells and that they are associated with the same (NSE) and the same RA. The BSS applies data forwarding (from the old cell to the new cell) for PFCs that it determines are to receive PS handover treatment.

NOTE 1: The MS does not know if optimised or non-optimised intra-BSS PS handover procedures are used.

3. The BSS sends the **PS Handover Command** (Handover Reference, Target BSS to Source BSS Transparent Container [RN part, CN part]) message to the MS by interrupting the transmission of LLC PDUs on any of the downlink TBFs. Following the transmission of this signalling message the BSS immediately resumes LLC PDU transmission until it either has no more LLC PDUs to send or the PFC is released. MS management of uplink N-PDUs following the reception of the **PS Handover Command** message is as follows:
  - All uplink packets associated with a PFC receiving handover treatment that have not yet been fully transmitted might be buffered depending on the QoS class.
  - Subsequent uplink packets that become available for transmission following the reception of the **PS Handover Command** message might also be buffered depending on the QoS class.
  - The MS may discard uplink packets during the link interruption to preserve the real-time properties.
4. The MS tunes to the radio channel and the timeslot allocated in the target cell by the BSS and sends the **PS Handover Access** (Handover Reference) message in the form of four handover access bursts) to the BSS on the allocated channel. The **PS Handover Command** message may indicate that the **PS Handover Access** message is optional to send by the MS.

5. The BSS sends a **Physical information** message (see 3GPP TS 23.108 [20]) to the MS to synchronise.

NOTE 2: In the synchronised networks case the MS receives the timing advance information to use in uplink in the target cell in the **PS Handover Command** message. In this case the sending of the **Physical information** message in the target cell is omitted.

6. The MS sends an arbitrary LLC frame to the SGSN, which in the SGSN is interpreted as an implicit cell update. To make the handover interruption short the MS sends this message immediately after receiving the **Physical Information** message or, in the synchronised network case, immediately after the sending of the **PS Handover Access** message. Upon reception of the first correct RLC/MAC block (sent in normal burst format) from the MS the BSS releases the radio resources in the source cell. The reception of the Cell Update message at the SGSN triggers the sending of downlink data to the new cell using a new BVCI if it is addressed by a different BVCI.

7. The SGSN responds to the Cell Update with a FLUSH-LL message.

8. The BSS returns the FLUSH-LL\_ACK message indicating if unsent LLC PDUs have been deleted or transferred to the new cell. If the BSS supports forwarding of LLC PDUs to the new cell it may indicate (within the FLUSH-LL\_ACK message) that unsent LLC PDUs have been transferred. This is however implementation specific for the BSS.

9. The first DL PDU received by the BSS with the new-BVCI allows the BSS to clear the relationship to the old BVCI.

NOTE 3: It is assumed here that downlink flow control is carried out on a per PFC basis and that the PFC specific flow control parameters remain the same upon MS arrival in the target cell.

## 5.1.3 Intra SGSN

### 5.1.3.1 Intra SGSN/Inter BSS HO, Preparation phase

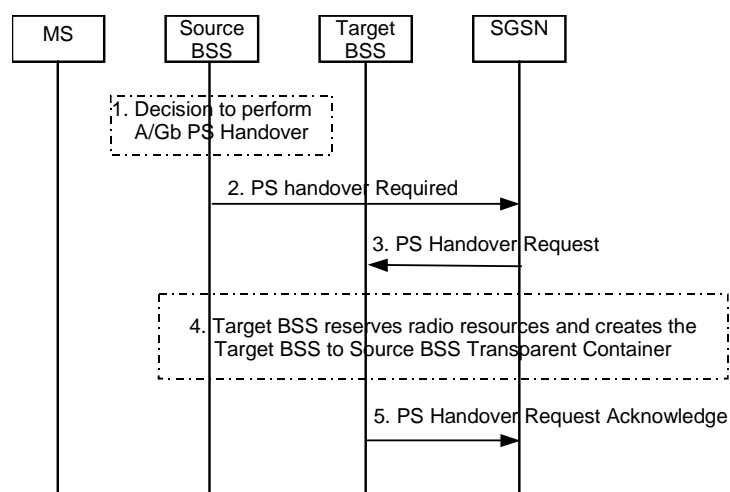

**Figure 7: PS Handover Preparation Phase; Intra-SGSN/Inter-BSS case (GERAN A/Gb → GERAN A/Gb)**

1. The source BSS decides to initiate a PS handover. At this point both uplink and downlink user data is transmitted via the following: TBFs between MS and source BSS, BSSGP PFCs tunnel(s) between the source BSS and SGSN, GTP tunnel(s) between the SGSN and GGSN.
2. The source BSS sends a **PS Handover Required** (TLLI, Cause, Source Cell Identifier, Target Cell Identifier, Source BSS to Target BSS Transparent Container [RN part]) message to the SGSN.
3. The SGSN determines from the Target ID the type of handover, i.e. intra-SGSN, inter-SGSN or inter-RAT/mode handover. In case of Intra-SGSN PS handover, the SGSN sends a **PS Handover Request** (TLLI, Cause, IMSI, Source Cell Identifier, Target Cell Identifier, PFCs To Be Set Up List, Source BSS to Target BSS Transparent Container [RN part]) message to the target BSS. The SGSN shall not request resources for PFCs associated with PDP contexts with a maximum bit rate for uplink and downlink of 0 kbit/s.

NOTE 1: The BSS PFCs required to be set up are downloaded to the target BSS from the SGSN, i.e.all information required for PFC creation.

NOTE 2: The XID Command message is not included in the **PS Handover Request** message in case of Intra-SGSN PS Handover, and thus the **PS Handover BSS PFC Status Report** message shall never be sent in this case.

- Based upon the ABQP for each PFC the target BSS makes a decision about which PFCs to assign radio resources. The algorithm by which the BSS decides which PFCs that need resources is implementation specific. Due to resource limitations not all downloaded PFCs will necessarily receive resource allocation. The target BSS allocates TBFs for each PFC that can be accommodated by the target BSS.

After allocating radio resources the target BSS shall prepare the Target BSS to Source BSS Transparent Container for the set up BSS PFCs.

- The target BSS sends the **PS Handover Request Acknowledge** (TLLI, Cause, PFCs Set Up/Failed to Set Up, Target BSS to Source BSS Transparent Container [RN part, CN part]) message to the SGSN for the accepted PFCs. Upon sending the **PS Handover Request Acknowledge** message the target BSS shall be prepared to receive downlink LLC PDUs from the SGSN for the accepted PFCs.

When the SGSN receives the **PS Handover Request Acknowledge** message and it decides to proceed with the handover, the preparation phase is finished and the execution phase will follow.

### 5.1.3.2 Intra SGSN/Inter BSS HO, Execution phase

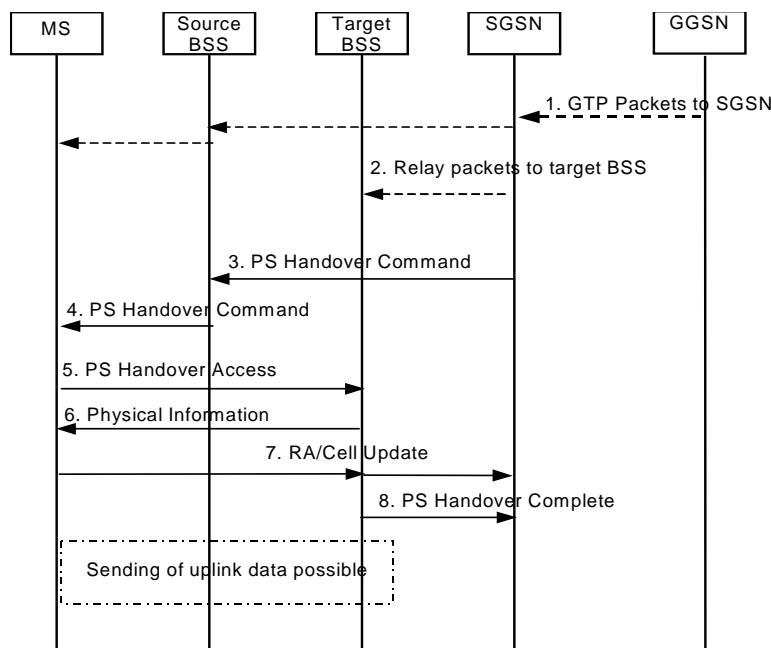

Figure 8: PS Handover Execution Phase; Intra-SGSN/Inter-BSS case (GERAN A/Gb → GERAN A/Gb)

- The SGSN continues to receive GTP packets from the GGSN (via GTP) and forwards the associated PDU payload to the MS via the source BSS.
- When receiving the **PS Handover Request Acknowledge** message the SGSN may, based on QoS, start duplication of LLC PDUs and forward those to the target BSS. If the SGSN forwards downlink packets to the target BSS, the target BSS may start blind transmission of downlink user data towards the MS over the allocated radio channels.
- The SGSN continues the PS Handover by sending a **PS Handover Command** (TLLI, Cause, PFCs To Be Set Up List ,Target BSS to Source BSS Transparent Container [RN part, CN part,]) message to the source BSS.

Before sending the **PS Handover Command** message, the SGSN based on QoS, suspends downlink data transfer for PDP contexts, which are sensitive to packet loss.

Before sending the **PS Handover Command** message to the MS the source BSS, based on QoS, tries to empty the downlink BSS buffer for BSS PFCs, which are sensitive to packet loss.

The source BSS receiving the **PS Handover Command** message stops the uplink traffic, based on QoS, for flows, which require delivery order to be preserved.

NOTE 1: Only PFI(s) for PFCs accepted by the target cell are included in the message.

4. The source BSS sends the **PS Handover Command** (Handover Reference, Target BSS to Source BSS Transparent Container [RN part, CN part]) message to the MS by interrupting the transmission of LLC PDUs on any of the downlink TBFs. Following the transmission of this signalling message the source BSS immediately resumes LLC PDU transmission until it either has no more LLC PDUs to send or the PFC is released. MS management of uplink N-PDUs following the reception of the **PS Handover Command** message is as follows:
  - All uplink packets associated with a PFC receiving handover treatment that have not yet been fully transmitted might be buffered depending on the QoS class.
  - Subsequent uplink packets that become available for transmission following the reception of the **PS Handover Command** message might also be buffered depending on the QoS class.
  - The MS may discard uplink packets during the link interruption to preserve the real-time properties.
5. The MS tunes to the radio channel and the timeslot allocated in the target cell by the BSS and sends the **PS Handover Access** (Handover Reference) message in the form of four handover access bursts to the BSS on the allocated channel. The **PS Handover Command** message may indicate that the **PS Handover Access** message is optional to send by the MS.
6. The target BSS sends a **Physical information** message (see 3GPP TS 23.108 [20]) to the MS for the MS to synchronise.

NOTE 2: In the synchronised networks case the MS receives the timing advance information to use in uplink in the target cell in the **PS Handover Command** message. In this case the sending of the **Physical information** message in the target cell is omitted.

7. In case the target cell is within the same routing area as the source cell, the MS sends an arbitrary LLC frame to the SGSN, which is interpreted as a cell update to the SGSN. In case the target cell is within another routing area, the MS sends a **Routing Area Update Request** message to the SGSN. To make the handover interruption short the MS sends this message immediately after receiving the **Physical Information** message or, in the synchronised network case, immediately after the sending of the **PS Handover Access** message.
8. Upon reception of the first correct RLC/MAC block (sent in normal burst format) from the MS the target BSS sends a **PS Handover Complete** (TLLI, Handover Complete Status) message to inform the PFM entity in the SGSN that the MS has arrived in the target cell. The source BSS initiates the release of the radio resources in the source cell. After the reception of the **PS Handover Complete** message the SGSN shall be prepared to receive data from the new cell.



## 5.1.4 Inter SGSN

### 5.1.4.1 Inter SGSN HO, Preparation phase

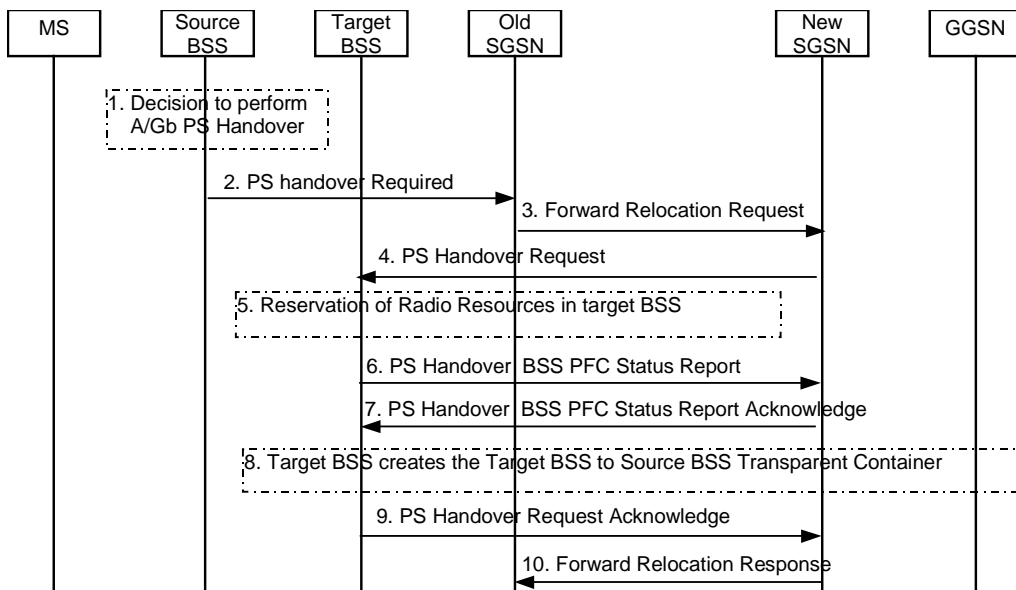

**Figure 9: PS Handover Preparation Phase; Inter-SGSN case (GERAN A/Gb → GERAN A/Gb)**

1. The source BSS decides to initiate a PS handover. At this point both uplink and downlink user data is transmitted via the following: TBFs between MS and source BSS, BSSGP PFCs tunnel(s) between source BSS and old SGSN, GTP tunnel(s) between old SGSN and GGSN.
2. The source BSS sends a **PS Handover Required** (Old TLLI, Cause, Source Cell Identifier, Target Cell Identifier, Source BSS to Target BSS Transparent Container [RN part]) message to the old SGSN.
3. The old SGSN determines from the Target ID the type of handover, i.e. intra-SGSN, inter-SGSN or inter-RAT/mode handover. In case of inter-SGSN PS Handover, the old SGSN initiates the PS Handover resource allocation procedure by sending a **Forward Relocation Request** (IMSI, Cause, Source Cell Identifier, Target Cell Identifier, MM Context, PDP Contexts, Packet Flow ID, SNDCP XID parameters, LLC XID parameters, Tunnel Endpoint Identifier Control Plane, SGSN Address, Source BSS to Target BSS Transparent Container [RN part], PDP Context Prioritisation) message to the new SGSN. The old SGSN sends all active PDP contexts to the new SGSN indicating the PFIs and the XID parameters related to those PDP contexts.

As part of the MM context the following security related information is included:

- Kc                                      Cipherng key for GPRS.
- CKSN                                    Cipherng Key Sequence Number of Kc.
- Used Cipher                            Selected cipherng algorithm for GPRS (GEA).
- MS Network Capability              Includes cipherng algorithms supported by the MS.

The Cipherng key used by the old SGSN is reused by the new SGSN until a new authentication procedure is performed (see clause 5.1.4.2, bullet 13).

If the new SGSN does not support the indicated cipherng algorithm, the new SGSN has to select a new cipherng algorithm. This new algorithm will be sent transparently from the new SGSN to the MS. The IOV-UI parameter generated in the new SGSN and used as input to the cipherng procedure will also be transferred transparently from the new SGSN to the MS.

When the new SGSN receives the **Forward Relocation Request** message it extracts from the PDP Contexts the associated NSAPIs, SAPIs and PFIs to be used in the new SGSN. In case when the new SGSN does not support the same SAPI and PFI for a certain NSAPI as the old SGSN, the new SGSN shall continue the PS handover procedure only for those NSAPIs for which it can support the same PFI and SAPI as the old SGSN and for which it can allocate resources. All PDP contexts for which no resources are allocated by the new SGSN or for which it cannot support the same SAPI and PFI (i.e. the corresponding NSAPIs are not addressed in the Forward Location Response message of the target SGSN), are maintained in the new SGSN and the related SAPIs and PFIs are kept. When this occurs the packet data transfer corresponding to PDP Contexts for which new SAPI and PFI values are needed are suspended. These PDP contexts may be modified or deactivated by the new SGSN via explicit SM procedures upon the completion of the routing area update (RAU) procedure. When the required PDP, MM, SNDCP and LLC contexts are established and the mapping between N-SAPI, SAPI and PFI for each of these PDP Contexts is established, the corresponding packet data transfer can continue.

NOTE 1: XID parameters shall be sent from the old SGSN to the new SGSN and indicate the current XID parameter settings (i.e. those used at the old SGSN).

- If the new SGSN can accept all XID parameters in use for a given N-SAPI it may send a corresponding XID Command that indicates the same XID parameters and new IOVs to the target BSS.
- If the new SGSN can't accept any of the XID parameters in use for a given N-SAPI it may send a corresponding XID Command that indicates new XID parameters and new IOVs to the target BSS.
- If the new SGSN can't accept some of the XID parameters in use for a given N-SAPI it may send a corresponding XID Command that indicates the same XID parameters for those that could be accepted and new ones for those that could not be accepted, and new IOVs to the target BSS.

If the new SGSN does not execute any of the above three alternatives it shall instead send an XID Command indicating Reset and new IOVs to the target BSS.

NOTE 2: The handling of XID negotiation is as specified in 3GPP TS 44.064 [21].

4. In case of Inter-SGSN PS handover, the new SGSN sends a **PS Handover Request** (Local TLLI, Cause, IMSI, Source Cell Identifier, Target Cell Identifier, Source BSS to Target BSS Transparent Container [RN part], PFCs To Be Set Up List, XID Command) message to the target BSS. The new SGSN shall not request resources for PFCs associated with PDP contexts with a maximum bit rate for uplink and downlink of 0 kbit/s.

NOTE 3: The BSS PFCs required to be set up are downloaded to the target BSS from the new SGSN, i.e.all information required for PFC creation.

NOTE 4: For each N-SAPI associated to a PFC in the PFCs To Be Set Up List, the new SGSN shall provide an XID Command.

5. Based upon the ABQP for each PFC the target BSS makes a decision about which PFCs to assign radio resources. The algorithm by which the BSS decides which PFCs that need resources is implementation specific. Due to resource limitations not all downloaded PFCs will necessarily receive resource allocation. The target BSS allocates TBFs for each PFC that can be accommodated by the target BSS.
6. If the target BSS is not able to allocate resources for one or more BSS PFCs it shall send a **PS Handover Status Report** (Setup PFC, Failed to Setup PFCs) message to the new SGSN.
7. Upon receiving the **PS Handover BSS PFC Status Report** message the new SGSN sends the XID Command for each of the set up PFCs to the target BSS in the **PS Handover BSS PFC Status Report Acknowledge** (XID Command for the set up BSS PFC) message.
8. After receiving all the necessary information for the accepted PFCs the target BSS shall prepare the Target BSS to Source BSS Transparent Container including the XID Commands only for the set up BSS PFCs.
9. The target BSS shall send the **PS Handover Request Acknowledge** (Local TLLI, Cause, PFCs Setup/Failed to Setup, Target BSS to Source BSS Transparent Container [RN part, CN part,]) message to the new SGSN for the accepted PFCs. Upon sending the **PS Handover Request Acknowledge** message the target BSS shall be prepared to receive downlink LLC PDUs from the new SGSN for the accepted PFCs.

10. When the new SGSN receives the **PS Handover Request Acknowledge** message the **Forward Relocation Response** (IMSI, Cause, NSAPI(s), Target BSS to Source BSS Transparent Container [RN part, CN part], UTRAN Transparent Container, Tunnel Endpoint Identifier Control Plane, SGSN Address, Tunnel Endpoint Identifier Data II) message is sent from the new SGSN to the old SGSN. This message indicates that the new SGSN is ready to receive packets forwarded from the old SGSN. If the target BSS or the new SGSN failed to allocate resources this shall be indicated in the message. The Tunnel Endpoint Identifier Data II, one information for each PDP context, contains the tunnel endpoint of the new SGSN and the IP address of the new SGSN for data forwarding from the old to the new SGSN.

The new SGSN activates the allocated LLC/SNDCP engines using initial sequence numbers of zero.

When the old SGSN receives the **Forward Relocation Response** message and it decides to proceed with the handover, the preparation phase is finished and the execution phase will follow.

### 5.1.4.2 Inter SGSN HO, Execution phase

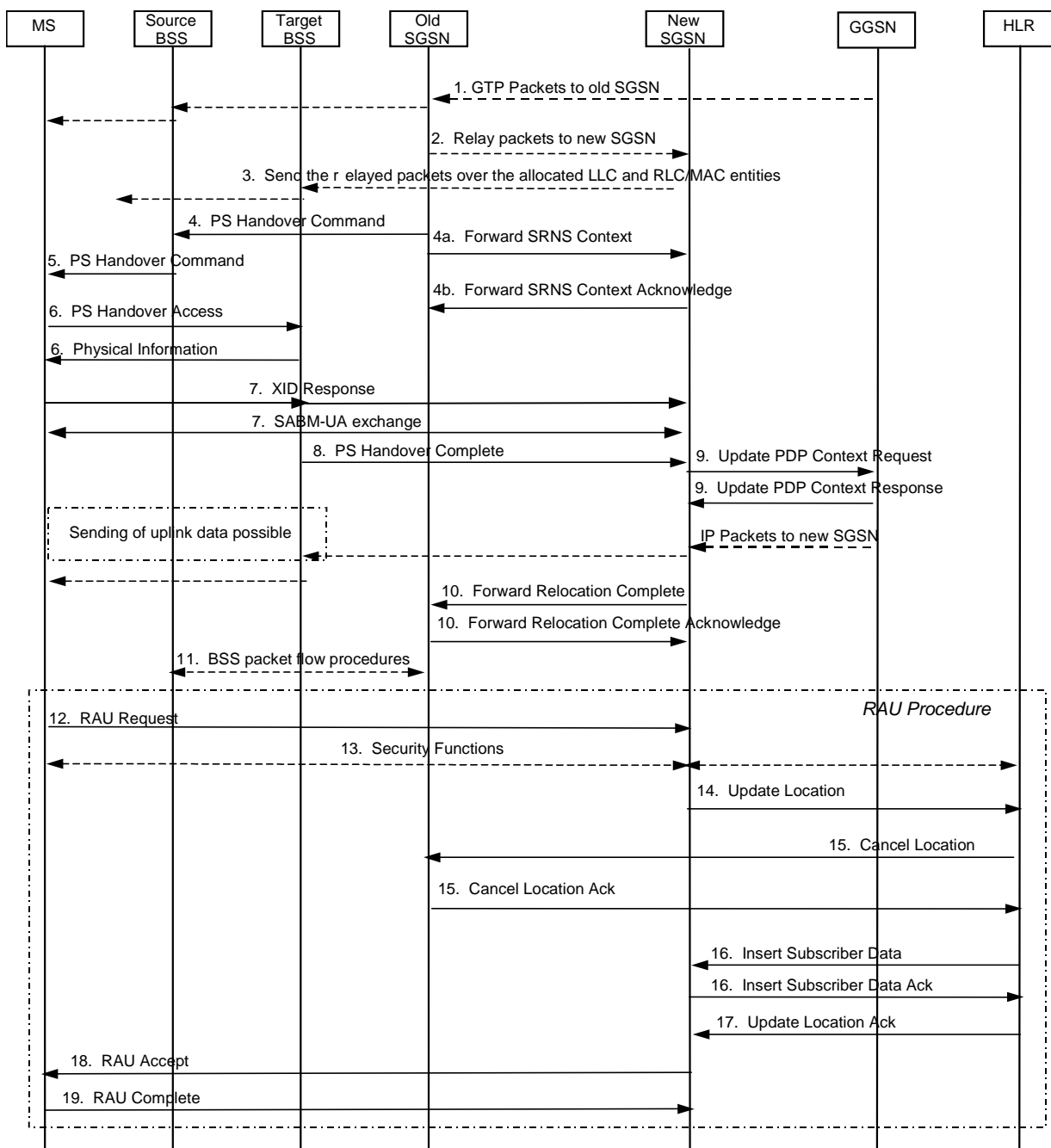

Figure 10: PS Handover Execution Phase; Inter-SGSN case (GERAN A/Gb → GERAN A/Gb)

1. The old SGSN continues to receive GTP packets from the GGSN (via GTP) and forwards the associated PDU payload to the MS via the source BSS.
2. If a Tunnel Endpoint is available the old SGSN may, based on QoS, start N-PDU relay and duplication to the new SGSN.
  - For each PDP context which uses LLC ABM in the old SGSN, all new downlink N-PDUs received after completion of the PS handover preparation phase are relayed to the new SGSN and the transmitted but not yet acknowledged downlink N-PDUs are duplicated and routed to the new SGSN. All such N-PDUs are encapsulated in a GTP-PDU when transmitted to the new SGSN together with their related N-PDU number.
  - For PDP context which uses LLC ADM in the old SGSN all new downlink N-PDUs received after completion of the PS handover preparation phase are relayed to the new SGSN. All such N-PDUs are encapsulated in a GTP-PDU when transmitted to the new SGSN.

NOTE 1: The order of steps, starting from step 2 onwards, does not necessarily reflect the order of events. For instance the old SGSN may start data forwarding (step 2), send the **PS Handover Command** message (step 4) and send the **Forward SRNS Context** message (step 4a) almost simultaneously.

3. The new SGSN may, based on QoS, proceed with the packet handling as follows:
  - For PDP context(s) which uses LLC ABM the new SGSN stores the N-PDUs associated with their number into the SNDCP queue. Data transfer prior the exchange of N-PDU SNs is not possible.
  - For PDP context(s) which uses LLC ADM the new SGSN either
    - a. forwards the received downlink N-PDUs to the target BSS;
    - b. stores the received data into the SNDCP queue for e.g. the PDU lifetime;
    - c. discards the received data until e.g. reception of the **PS Handover Complete** message.

If the new SGSN forwards downlink packets to the target BSS, the target BSS may start a blind transmission of downlink user data towards the MS over the allocated radio channels.

4. The old SGSN continues the PS Handover by sending a **PS Handover Command** (Old TLLI, Cause, PFCs To Be Set Up List, Target BSS to Source BSS Transparent Container [RN part, CN part]) message to the source BSS.

Before sending the **PS Handover Command** message, the old SGSN based on QoS, suspends downlink data transfer:

- for PDP contexts, which require delivery order to be preserved; and
- for PDP contexts, which are sensitive to packet loss.

Before sending the **PS Handover Command** message to the MS the source BSS, based on QoS, tries to empty the downlink BSS buffer:

- for BSS PFCs, which require delivery order to be preserved; and
- for BSS PFCs, which are sensitive to packet loss.

The source BSS receiving the **PS Handover Command** message stops the UL traffic, based on QoS, for flows, which require delivery order to be preserved.

NOTE 2: Only PFI(s) for PFCs accepted by the target cell are included in the message.

- 4a. The old SGSN shall send the **Forward SRNS Context** (Send N-PDU number, Receive N-PDU number, DL GTP-U number, UL GTP-U number) message to the new SGSN if there is at least one PDP context which either requires "delivery order" to be preserved or which uses LLC ABM. The **Forward SRNS Context** message is then acknowledged by the **Forward SRNS Context Acknowledge** message. The **Forward SRNS Context** message contains the sequence numbers of the GTP-PDU next to transmitted in the uplink and downlink direction and the next N-PDU number that would have been used to send and receive data from the MS.

The N-PDU sequence numbers are only sent by the old SGSN for PDP contexts, which uses LLC ABM. The GTP-U sequence numbers are only sent by the old SGSN for PDP context(s) requiring delivery order (QoS profile) to be preserved. If delivery order is to be preserved (QoS profile), consecutive GTP-PDU sequence numbering shall be maintained through the lifetime of the PDP context(s).

Therefore, during the entire PS Handover procedure for the PDP context(s) using delivery order required (QoS profile), the responsible GTP-U entities (SGSNs and GGSN) shall assign consecutive GTP-PDU sequence numbers to user packets belonging to the same PDP context uplink and downlink, respectively.

From now on the new SGSN uses:

- the initial N-PDU sequence number of zero for each activated SMDCP engine for LLC ADM;
  - the N-PDU sequence number provided by the old SGSN in the Forward SRNS context procedure for each activated SMDCP engine for LLC ABM.
5. The source BSS sends the **PS Handover Command** (Handover Reference, Target BSS to Source BSS Transparent Container [RN part, CN part]) message to the MS by interrupting the transmission of LLC PDUs on any of the downlink TBFs. Following the transmission of this signalling message the source BSS immediately resumes LLC PDU transmission until it either has no more LLC PDUs to send or the PFC is released. Upon reception of the **PS Handover Command** the MS shall suspend the uplink transmission of user plane data. The MS management of uplink N-PDUs following the reception of the **PS Handover Command** message is as follows:
- All uplink packets associated with a PFC receiving handover treatment that have not yet been fully transmitted might be buffered depending on the QoS class.
  - Subsequent uplink packets that become available for transmission following the reception of the **PS Handover Command** message might also be buffered depending on the QoS class.
  - The MS may discarded uplink packets during the link interruption to preserve the real-time properties.
6. The MS tunes to the radio channel and the timeslot allocated in the target cell by the target BSS and sends the **PS Handover Access** (Handover Reference) message in the form of four handover access bursts to the target BSS on the allocated channel. The **PS Handover Command** message may indicate that the **PS Handover Access** message is optional to send by the MS. The target BSS sends a **Physical information** message (see 3GPP TS 23.108 [20]) to the MS for the MS to synchronise.

NOTE 3: In the synchronised networks case the MS receives the timing advance information to use in uplink in the target cell in the **PS Handover Command** message. In this case the sending of the **Physical Information** message in the target cell is omitted.

7. The MS sends one **XID Response** message to the new SGSN for each **XID Command** message received in the source cell, thereby informing the SGSN about the negotiated security parameters. For LLC ABM, the **XID Response** message is followed by a SABM-UA exchange procedure as defined in TS 44.064. To make the handover interruption short the MS sends this message immediately after receiving the **Physical Information** message or, in the synchronised network case, immediately after the sending of the **PS Handover Access** message.

After successful XID negotiation the MS shall resume the user data transfer only for those NSAPIs for which there are radio resources allocated in the target cell. All other NSAPIs shall be handled following the legacy procedures during routing area change, thus the MS shall not resume the uplink user data transfer until the routing area update procedure is completed.

8. Upon reception of the first correct RLC/MAC block (sent in normal burst format) from the MS the target BSS sends a **PS Handover Complete** (Local TLLI, Handover Complete Status) message to inform the PFM entity in the SGSN that the MS has arrived in the target cell. The source BSS initiates the release of the radio resources in the source cell. After the reception of the **PS Handover Complete** message the new SGSN shall be prepared to receive data from the target BSS.
9. The new SGSN sends an **Update PDP Context Request** (New SGSN Address, TEID, QoS Negotiated) message to the GGSN concerned. The GGSN updates the PDP context fields and returns an **Update PDP Context Response** (TEID) message. From now on the GGSN sends new incoming downlink IP packets only to the new SGSN. Each uplink N-PDU received by the new SGSN prior to updating the PDP Context for the associated PFC by the **Update PDP Context Request** message is discarded. Once the new SGSN has updated the PDP Context for any given PFC, it starts sending all associated uplink N-PDUs it receives directly to the GGSN.
10. The new SGSN sends a **Forward Relocation Complete** (IMSI, Handover Complete Status) message to the old SGSN. The old SGSN responds with a **Forward Relocation Complete Acknowledge** message. Upon the reception of the **Forward Relocation Complete** message the old SGSN starts a packet forwarding timer. The old SGSN stops forwarding of data to the new SGSN after the packet forwarding timer expires.
11. The old SGSN deletes to BSS packet flow context towards the old cell.
12. The MS sends a **Routing Area Update Request** (Old RAI, Old P-TMSI signature) message to the new SGSN informing it that the source cell belongs to a new routing area. The MS shall send this message immediately after message 6. The new SGSN knows that a handover has been performed for this MS and can therefore exclude the SGSN context procedures that normally are used within the RA Update procedure.
13. At this point the new SGSN may optionally invoke MS authentication (security function). The security function can be deferred and performed at any later time as well.
14. The new SGSN informs the HLR of the change of SGSN by sending **Update Location** (SGSN Number, SGSN Address, IMSI) message to the HLR.
15. The HLR sends **Cancel Location** (IMSI, Cancellation Type) message to the old SGSN with Cancellation Type set to Update Procedure. The old SGSN acknowledges with a **Cancel Location Acknowledge** (IMSI) message. This message allows the old SGSN to know when to release the inter-SGSN tunnel.
16. The HLR sends **Insert Subscriber Data** (IMSI, GPRS subscription data) to the new SGSN. The new SGSN validates the MS presence in the (new) RA. If all checks are successful then the new SGSN constructs an MM context for the MS and returns an **Insert Subscriber Data Acknowledge** (IMSI) message to the HLR. This message allows the new SGSN to know when to release the inter-SGSN tunnel.
17. The HLR acknowledges the Update Location by sending an **Update Location Acknowledge** (IMSI) message to the new SGSN.
18. The new SGSN validates the MS presence in the new RA. If the MS is allowed to be attached in this RA, the SGSN updates the MM context for and sends a **Routing Area Update Accept** (P-TMSI, TMSI, P-TMSI signature, Receive N-PDU number) message to the MS. The Receive N-PDU Number contains the acknowledgements for each acknowledged-mode NSAPI used by the SGSN, thereby confirming all mobile-originated N-PDUs successfully transferred before the start of the PS handover procedure.
19. The MS confirms the re-allocation of the new P-TMSI by responding the SGSN with a **Routing Area Update Complete** (Receive N-PDU number) message. The MS derives a new local TLLI from the new P-TMSI using current MM procedures. The Receive N-PDU Number contains the acknowledgements for each acknowledged-mode NSAPI used by the MS, thereby confirming all mobile-terminated N-PDUs successfully transferred before the start of the handover procedure. If Receive N-PDU Number confirms reception of N-PDUs that were forwarded from the old SGSN, these N-PDUs shall be discarded by the new SGSN.

## 5.2 Inter-RAT/mode handover (GERAN A/Gb → UTRAN, GERAN Iu)

### 5.2.1 Intra SGSN

#### 5.2.1.1 Intra-SGSN GERAN A/Gb to UTRAN/GERAN Iu HO; Preparation phase

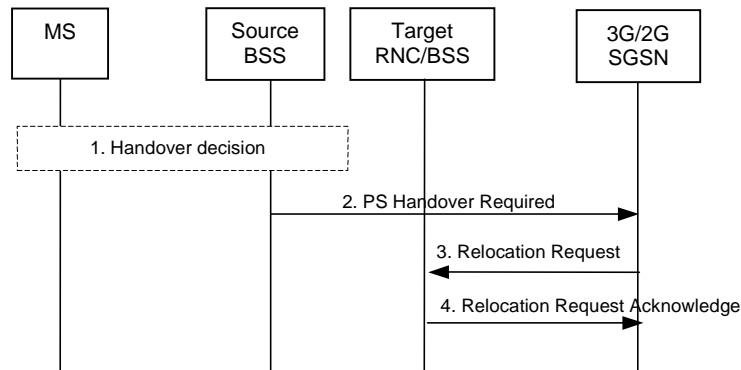

**Figure 11: PS Handover Preparation Phase; Inter-RAT/mode, Intra-SGSN case (GERAN A/Gb → UTRAN, GERAN Iu)**

1. The source BSS decides to initiate a PS handover. At this point both uplink and downlink user data is transmitted via the following: TBFs between MS and source BSS, BSSGP PFCs tunnel(s) between the source BSS and 3G/2G SGSN, GTP tunnel(s) between the 3G/2G SGSN and GGSN.
2. The source BSS sends a **PS Handover Required** (TLLI, Source Cell Identifier, Target ID, Source RNC to Target RNC Transparent Container) message to the SGSN.
3. The 3G/2G SGSN determines from the Target ID the type of handover, i.e. intra-SGSN, inter-SGSN or inter-RAT/mode handover. In case of Inter-RAT/Intra-SGSN PS handover, the 3G/2G SGSN constructs a **Relocation Request** (Permanent NAS Identity, Cause, CN Domain Indicator, Integrity protection information (i.e. IK and allowed Integrity Protection algorithms, Encryption information (i.e. CK and allowed Ciphering algorithms), RABs To Be Set Up List, Source RNC to Target RNC Transparent Container, Iu Signalling connection identifier, Global CN-ID, SNA Access Information, UESBI-Iu) message to the target RNC/BSS.

For each RAB requested to be established, the RABs To Be Set Up List shall contain information such as RAB ID, RAB parameters, Transport Layer Address, and Iu Transport Association. The 3G/2G SGSN shall not request resources for PFCs associated with PDP contexts with a maximum bit rate for uplink and downlink of 0 kbit/s. The RAB ID information element contains the NSAPI value, and the RAB parameters information element gives the QoS profile. The Transport Layer Address is the SGSN Address for user data, and the Iu Transport Association corresponds to the uplink Tunnel Endpoint Identifier Data.

Ciphering and integrity protection keys are sent to the target RNC/BSS to allow data transfer to continue in the new RAT/mode target cell without requiring a new AKA (Authentication and Key Agreement) procedure. Information that is required to be sent to the MS (either in the **PS Handover Command** message or after the handover completion message) from RRC in the target RNC/BSS shall be included in the RRC message sent from the target RNC/BSS to the MS via the transparent container.

In the target RNC/BSS radio and Iu user plane resources are reserved for the accepted RABs.

4. The target RNC/BSS sends the **Relocation Request Acknowledge** (Target RNC to Source RNC Transparent Container, RABs setup list, RABs failed to setup list) message to the 3G/2G SGSN for the accepted PFCs. Upon sending the **Relocation Request Acknowledge** message the target RNC/BSS shall be prepared to receive downlink LLC PDUs from the 3G/2G SGSN for the accepted PFCs.

Each RAB to be setup is defined by a Transport Layer Address, which is the target RNC/BSS Address for user data, and the Iu Transport Association, which corresponds to the downlink Tunnel Endpoint Identifier for user data.

NOTE: The information to be included in the containers differs for UTRAN and GERAN Iu mode. For UTRAN, the information included in the container is related to RAB setup and other IE similar to those in the **Handover to UTRAN** message defined in 3GPP TS 25.331 [17]. For GERAN Iu mode the **Radio Bearer Reconfiguration** message defined in 3GPP TS 44.118 [16] is the RRC message to be included.

When the 3G/2G SGSN receives the **Relocation Request Acknowledge** message and it decides to proceed with the handover, the preparation phase is finished and the execution phase will follow.

### 5.2.1.2 Intra-SGSN GERAN A/Gb to UTRAN/GERAN Iu HO; Execution phase

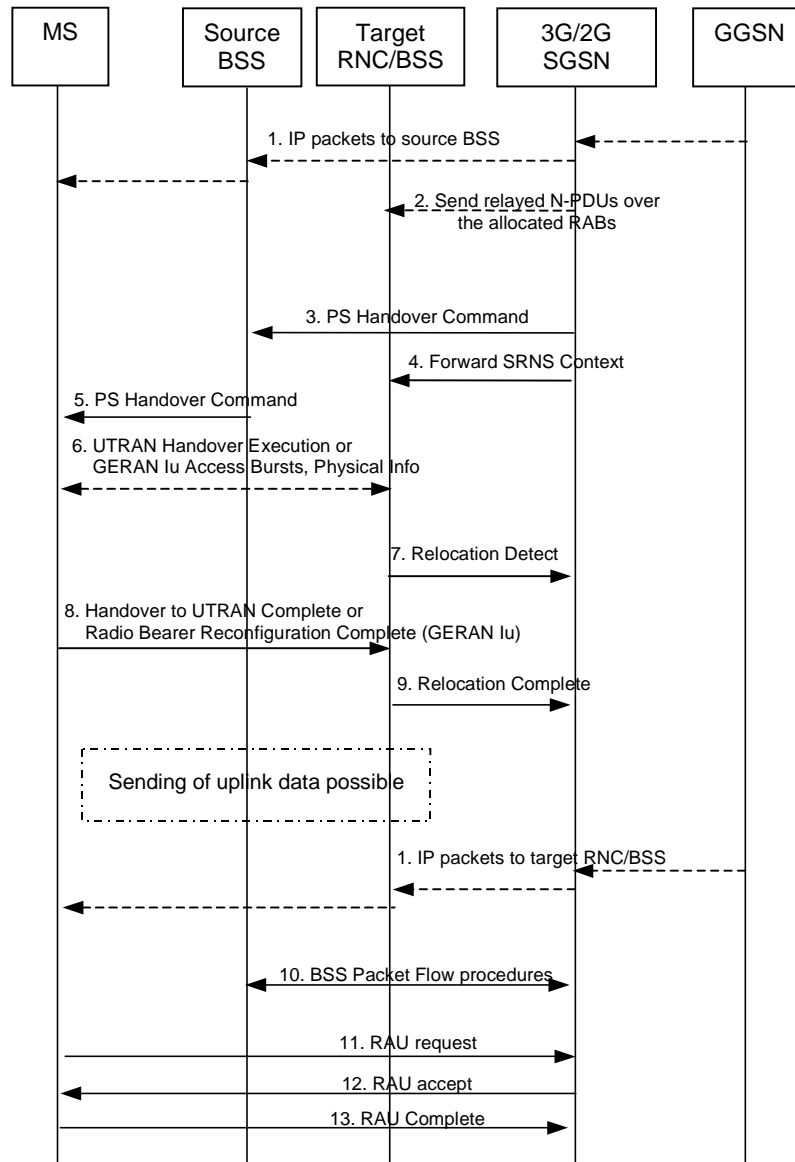

**Figure 12: PS Handover Execution Phase; Inter-RAT/mode, Intra-SGSN case (GERAN A/Gb → UTRAN, GERAN Iu)**

1. The 3G/2G SGSN continues to receive IP packets from the GGSN (via GTP) and forwards the associated PDU payload to the MS via the source BSS.
2. When receiving the **Relocation Request Acknowledge** message the 3G/2G SGSN may, based on QoS, start downlink N-PDU relay and duplication to the target RNC/BSS if a Tunnel Endpoint is available as follows:
  - For each PDP context which uses LLC ABM, all new downlink N-PDUs received after completion of the PS handover preparation phase are duplicated and relayed to the target RNC/BSS and the transmitted but not yet acknowledged downlink N-PDUs are duplicated and routed together with their N-PDU number to the target RNC/BSS. All such N-PDUs are encapsulated in a GTP-PDU when transmitted to the target RNC/BSS.



- For PDP context, which uses LLC ADM, all new downlink N-PDUs received after completion of the PS handover preparation phase are relayed to the target RNC. All such N-PDUs are encapsulated in a GTP-PDU when transmitted to the target RNC/BSS.
  - If the 3G/2G SGSN forwards downlink packets to the target RNC/BSS, the target RNC/BSS may start blind transmission of downlink user data towards the MS over the allocated radio channels.
  - In the network, N-PDUs are forwarded from the SGSN to the target RNC/BSS and the PDCP sequence number is derived from the N-PDU sequence number (sent as part of the PDP context) with the 8 most significant bit 1's added. It is FFS where this sequence number translation will be done.
3. The 3G/2G SGSN continues the PS Handover by sending a **PS Handover Command** (TLLI, Target RNC ID, PFCs To Be Set Up List, Target RNC to Source RNC Transparent Container) message to the source BSS.

Before sending the **PS Handover Command** message, the 3G/2G SGSN, based on QoS, suspends downlink data transfer:

- for PDP contexts, which require delivery order to be preserved; and
- for PDP contexts, which are sensitive to packet loss.

Before sending the **PS Handover Command** message to the MS the source BSS, based on QoS, tries to empty the downlink BSS buffer:

- for BSS PFCs, which require delivery order to be preserved; and
- for BSS PFCs, which are sensitive to packet loss.

The source BSS receiving the **PS Handover Command** message stops the uplink traffic, based on QoS, for flows, which require delivery order to be preserved.

4. The 3G/2G SGSN shall send the **Forward SRNS Context** (Send N-PDU number, Receive N-PDU number, DL GTP-U number, UL GTP-U number) message to the target RNC/BSS if there is at least one PDP context which either requires "delivery order" to be preserved or which uses LLC ABM. The forward SRNS message contains the sequence numbers of the GTP-PDU next to transmitted in the uplink and downlink direction and the next N-PDU number that would have been used to send and receive data from the MS.

The N-PDU numbers are only sent by the 3G/2G SGSN for PDP contexts, which uses LLC ABM. The GTP-U numbers are only sent by the 3G/2G SGSN for PDP context(s) requiring delivery order (QoS profile) to be preserved. If delivery order is to be preserved (QoS profile), consecutive GTP-PDU sequence numbering shall be maintained through the lifetime of the PDP context(s).

Therefore, during the entire PS Handover procedure for the PDP context(s) using delivery order required (QoS profile), the responsible GTP-U entities (3G/2G SGSN, target RNC/BSS and GGSN) shall assign consecutive GTP-PDU sequence numbers to user packets belonging to the same PDP context uplink and downlink, respectively.

The target RNC/BSS proceed as follows:

- For RABs which require lossless PDCP in the target RNC/BSS, the target RNC/BSS stores the N-PDUs in the PDCP queue and converts the Send N-PDU number (if present) into a PDCP sequence number by adding eight most significant bits "1".
- For RABs not requiring lossless PDCP the target RNC/BSS may, according the QoS profile of the PDP context, store the received data until it receives confirmation of MS presence in the target cell.

The further target RNC/BSS behaviour is as specified in 3GPP TS 23.060 [19] (Combined Hard Handover and SRNS Relocation).

5. The source BSS sends the **PS Handover Command** message containing the **Handover to UTRAN Command** message (as it is specified in 3GPP TS 25.331 [17]) or **Radio Bearer Reconfiguration** message (as it is specified in 3GPP TS 44.118 [16]) to the MS by interrupting the transmission of LLC PDUs on any of the downlink TBFs. Following the transmission of this signalling message the source BSS immediately resumes LLC PDU transmission until it either has no more LLC PDUs to send or the PFC is released. MS management of uplink N-PDUs following the reception of the **PS Handover Command** message is as follows:
  - All N-PDUs associated with a PFC receiving handover treatment that have not yet been fully transmitted might be buffered depending on the QoS class.
  - Subsequent uplink N-PDUs that become available for transmission following the reception of the **PS Handover Command** message might also be buffered depending on the QoS class.
  - For real time services uplink N-PDUs may be discarded by the MS during the link interruption.

NOTE: Any buffering should be performed before the data is passed to SNDCP in order to avoid header compression on N-PDUs such that data delivery in the target cell may begin from the correct point in the sequence.

6. MS is in the target cell and performs access to UTRAN as defined in 3GPP TS 25.331 [17] and to GERAN Iu mode as defined in 3GPP TS 44.118 [16].
7. The target RNC/BSS sends a **Relocation Detect** message to the 3G/2G SGSN to indicate that the MS is in the target cell. The message shall be sent when the relocation execution trigger is received. For SRNS relocation type "UE Involved", the relocation execution trigger may be received from the Uu interface; i.e. when the target RNC detects the MS on the lower layers. When the **Relocation Detect** message is sent, the target RNC shall start source RNC operation.
8. In UTRAN, the MS sends **Handover to UTRAN Complete** {Message Type, UE Information elements (Start List, CN Domain Identity, Start), RB Information Elements (Count-C Activation Time)} message to the target RNC (see 3GPP TS 25.331 [17]).

In GERAN Iu, the MS sends **Radio Bearer Reconfiguration Complete** {RRC Transaction Identifier, Integrity Check Info, Uplink Integrity Protection Activation Info, COUNT-C Activation Time, Radio Bearer Uplink Ciphering Activation Time Info, Mobile Observed Time Difference, Uplink Counter Synchronisation Info struct, START List, CN Domain Identity, START, RB with PDCP Information List, RB with PDCP Information} message to target BSS.

9. When the new source RNC-ID + S-RNTI are successfully exchanged with the MS, the target RNC/BSS shall send the **Relocation Complete** message to the new SGSN. The purpose of the Relocation Complete procedure is to indicate by the target RNC/BSS the completion of the relocation of the source BSS to the CN. After the reception of the **Relocation Complete** message the 3G/2G SGSN shall be prepared to receive data from the target RNC/BSS.
10. The 3G/2G SGSN shall initiate PFC Management procedures towards the source cell in order to trigger the release of resources in the source cell.
11. The MS sends a **Routing Area Update Request** (Old RAI, Old P-TMSI signature, Update Type) message to the 3G/2G SGSN informing it that the source cell belongs to a new routing area. The MS shall send this message immediately after message 8. The 3G/2G SGSN knows that a handover has been performed for this MS and can therefore exclude the SGSN context procedures which normally are used within the RA Update procedure.
12. The 3G/2G SGSN validates the MS presence in the new RA. If the MS is allowed to be attached in this RA, the 3G/2G SGSN updates the MM context for and sends a **Routing Area Update Accept** message to the MS.
13. The MS may respond to the SGSN with a **Routing Area Update Complete** message.

## 5.2.2 Inter SGSN

### 5.2.2.1 Inter-SGSN GERAN A/Gb to UTRAN/GERAN Iu HO; Preparation phase

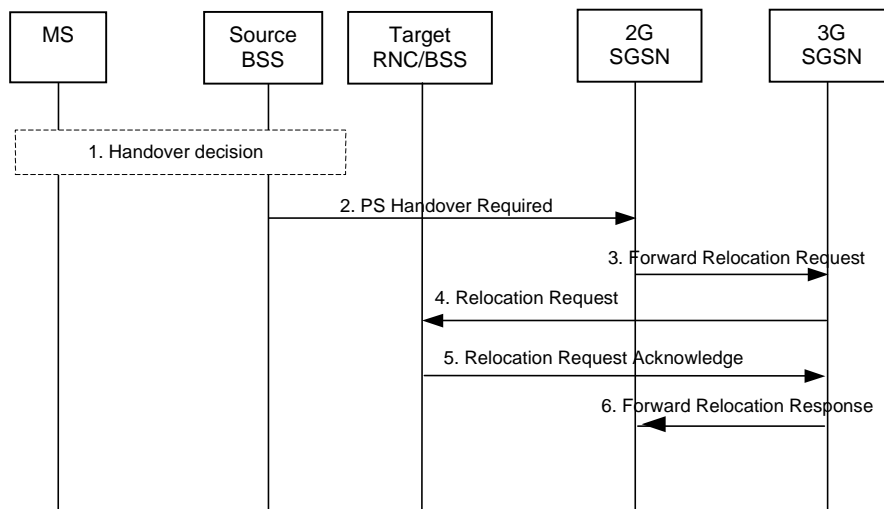

**Figure 13: PS Handover Preparation Phase; Inter-RAT/mode, Inter-SGSN case (GERAN A/Gb → UTRAN, GERAN Iu)**

1. The source BSS decides to initiate a PS handover. At this point both uplink and downlink user data is transmitted via the following: TBFs between MS and source BSS, BSSGP PFCs tunnel(s) between source BSS and old SGSN, GTP tunnel(s) between old SGSN and GGSN.
2. The source BSS sends a **PS Handover Required** (TLLI, Source Cell Identifier, Target ID, Source RNC to Target RNC Transparent Container) message to the old SGSN.
3. The old SGSN determines from the Target ID the type of handover, i.e. intra-SGSN, inter-SGSN or inter-RAT/mode handover. In case of inter-SGSN inter-RAT/mode PS handover the old SGSN initiates the relocation resource allocation procedure by sending a **Forward Relocation Request** (IMSI, Target Identification, MM Context, PDP Context, PDP Context Prioritisation, Tunnel Endpoint Identifier Control Plane, SGSN Address for Control plane, Source RNC to Target RNC Transparent Container, UTRAN Transparent Container, RANAP Cause) message to the new SGSN.

The old SGSN sends all active PDP Contexts to the new SGSN indicating the PFIs and the XID parameters related to those PDP Contexts.

As part of the MM context the following security related information is included:

- Kc Cipherring key for GPRS.
- CKSN Cipherring Key Sequence Number of Kc.
- Used Cipher Selected cipherring algorithm for GPRS (GEA).
- MS Network Capability Includes cipherring algorithms supported by the MS.

The values for CK (UMTS Cipherring Key) and IK (UMTS Integrity protection Key) are calculated from the Kc and the KSI (Key Set Identifier) takes the same value as CKSN.

NOTE 1: For relocation to an area where Intra Domain Connection of RAN Nodes to Multiple CN Nodes is used, the old SGSN may - if it provides Intra Domain Connection of RAN Nodes to Multiple CN Nodes - have multiple new SGSNs for each handover target in a pool area, in which case the old SGSN will select one of them to become the new SGSN, as specified in 3GPP TS 23.236 [22].

Upon receipt of the message, the new SGSN establishes all MM and PDP contexts and initiates the RAB setup procedures for all PDP contexts received.

1. In case of Inter-RAT/Inter-SGSN PS handover, the new SGSN constructs a **Relocation Request** (Permanent NAS Identity, Cause, CN Domain Indicator, Integrity protection information (i.e. IK and allowed Integrity Protection algorithms, Encryption information (i.e. CK and allowed Ciphering algorithms), RABs to be setup list, Source RNC to Target RNC Transparent Container, Iu Signalling connection identifier, Global CN-ID, SNA Access Information, UESBI-Iu) message to the target RNC/BSS.

For each RAB requested to be established, RABs To Be Setup shall contain information such as RAB ID, RAB parameters, Transport Layer Address, and Iu Transport Association. The new SGSN shall not request resources for PFCs associated with PDP contexts with a maximum bit rate for uplink and downlink of 0 kbit/s. The RAB ID information element contains the NSAPI value, and the RAB parameters information element gives the QoS profile. The Transport Layer Address is the SGSN Address for user data, and the Iu Transport Association corresponds to the uplink Tunnel Endpoint Identifier Data.

Ciphering and integrity protection keys are sent to the target RNC/BSS to allow data transfer to continue in the new RAT/mode target cell without requiring a new AKA (Authentication and Key Agreement) procedure. Information that is required to be sent to the MS (either in the **PS Handover Command** message or after the handover completion message) from RRC in the target RNC/BSS shall be included in the RRC message sent from the target RNC/BSS to the MS via the transparent container.

In the target RNC/BSS radio and Iu user plane resources are reserved for the accepted RABs.

2. The target RNC/BSS sends the **Relocation Request Acknowledge** (Target RNC to Source RNC Transparent Container, RABs setup list, RABs failed to setup list) message to the new SGSN. Upon sending the **Relocation Request Acknowledge** message the target RNC/BSS shall be prepared to receive downlink LLC PDUs from the new SGSN for the accepted PFCs.

Each RAB to be setup is defined by a Transport Layer Address, which is the target RNC/BSS Address for user data, and the Iu Transport Association, which corresponds to the downlink Tunnel Endpoint Identifier for user data.

NOTE 2: The information to be included in the containers differs for UTRAN and GERAN Iu mode. For UTRAN, the information included in the container is related to RAB setup and other IE similar to those in the **Handover to UTRAN** message defined in 3GPP TS 25.331 [17]. For GERAN *Iu mode* the **Radio Bearer Reconfiguration** message defined in 3GPP TS 44.118 [16] is the RRC message to be included.

3. When resources for the transmission of user data between target RNC/BSS and new SGSN have been allocated and the new SGSN is ready for the PS handover, the **Forward Relocation Response** (Cause, Tunnel Endpoint Identifier Control Plane, RANAP cause, SGSN Address for control plane, Target RNC to Source RNC Transparent Container in the UTRAN Transparent Container, RAB setup information, Additional RAB setup information) message is sent from the new SGSN to the old SGSN. RAN Transparent Container and RANAP Cause contain information from the target RNC/BSS to be forwarded to the source BSS.

The RAB Setup Information Element, one information for each PDP context, contains the RNC tunnel endpoint and the RNC IP address for data forwarding from the old SGSN to the target RNC.

When the old SGSN receives the **Forward Relocation Response** message and it decides to proceed with the handover, the preparation phase is finished and the execution phase will follow.

5.2.2.2 Inter-SGSN GERAN A/Gb to UTRAN/GERAN Iu HO; Execution phase

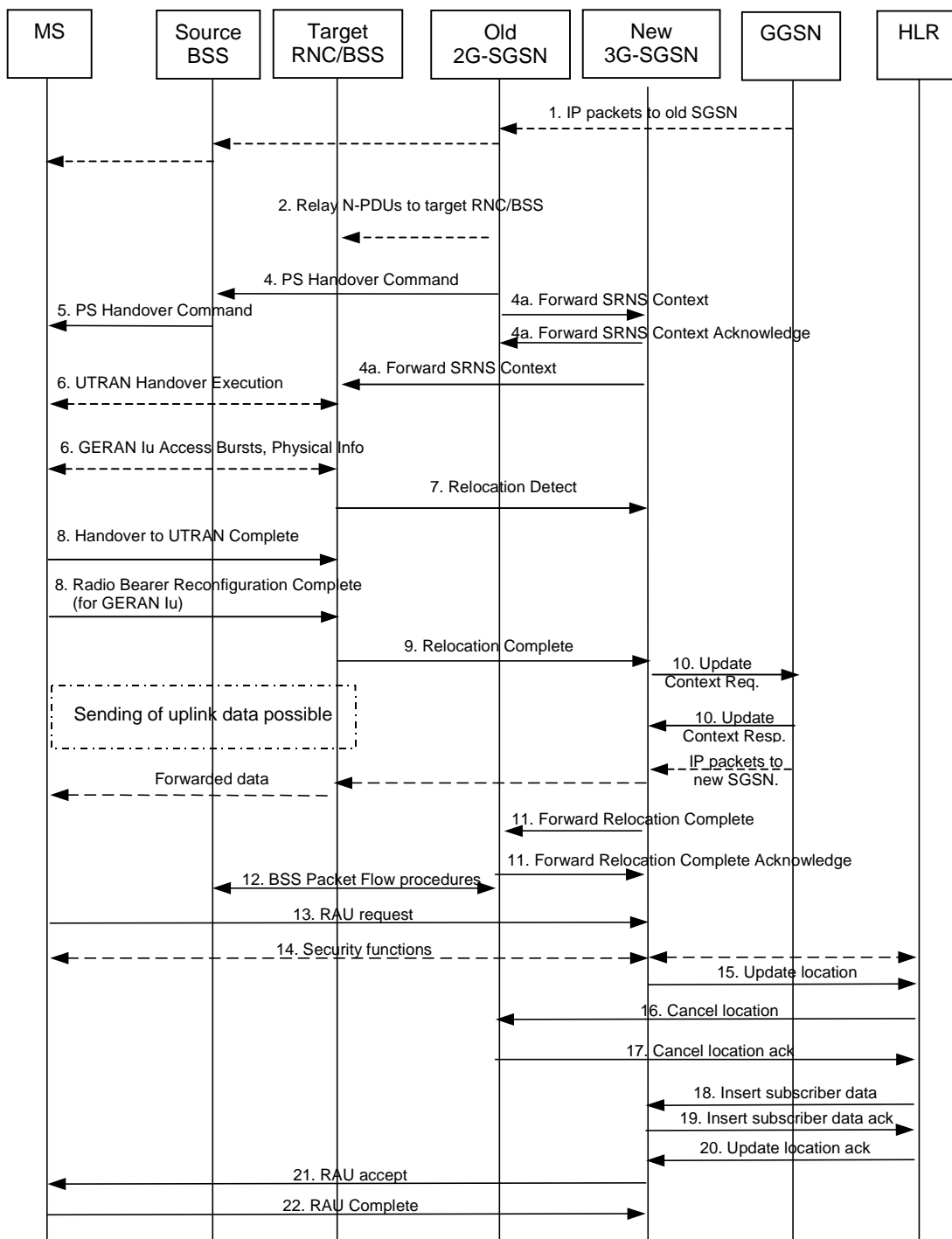

Figure 14: PS Handover Execution Phase; Inter-RAT/mode, Inter-SGSN case (GERAN A/Gb → UTRAN/GERAN Iu)

1. The old SGSN continues to receive IP packets from the GGSN (via GTP) and forwards the associated PDU payload to the MS via the source BSS.

2. When receiving the **Relocation Request Acknowledge** message the old SGSN may, based on QoS, start downlink N-PDU relay and duplication to the target RNC/BSS if a Tunnel Endpoint is available as follows:
  - For each PDP context which uses LLC ABM in the old SGSN, all new downlink N-PDUs received after completion of the PS handover preparation phase are duplicated and relayed to the target RNC/BSS and the transmitted but not yet acknowledged downlink N-PDUs are duplicated and routed together with their N-PDU number to the target RNC/BSS. All such N-PDUs are encapsulated in a GTP-PDU when transmitted to the target RNC/BSS.
  - For PDP context, which uses LLC ADM in the old SGSN all new downlink N-PDUs received after completion of the PS handover preparation phase are relayed to the target RNC/BSS. All such N-PDUs are encapsulated in a GTP-PDU when transmitted to the target RNC/BSS.

If the old SGSN forwards downlink packets to the target RNC/BSS, the target RNC/BSS may start blind transmission of downlink user data towards the MS over the allocated radio channels.

In the network, N-PDUs are forwarded from the old SGSN to the target RNC/BSS and the PDCP sequence number is derived from the N-PDU sequence number (sent as part of the PDP context) with 8 most significant bit 1's added. It is FFS where this sequence number translation will be done.

NOTE 1: The order of steps, starting from step 2 onwards, does not necessarily reflect the order of events. For instance the old SGSN may start data forwarding (step 2), send the PS Handover Command message (step 4) and send the Forward SRNS context message (step 4a) almost simultaneously.

3. Void
4. The old SGSN continues the PS Handover by sending a **PS Handover Command** (Old TLLI, Target RNC ID, PFCs To Be Set Up List, Target RNC to Source RNC Transparent Container) message to the source BSS.

Before sending the **PS Handover Command** message, the old SGSN based on QoS, suspends downlink data transfer:

- for PDP contexts, which require delivery order to be preserved; and
- for PDP contexts, which are sensitive to packet loss.

Before sending the **PS Handover Command** message to the MS the source BSS based on QoS, tries to empty the downlink BSS buffer:

- for BSS PFCs, which require delivery order to be preserved; and
- for BSS PFCs, which are sensitive to packet loss.

The source BSS receiving the **PS Handover Command** message stops the uplink traffic, based on QoS, for flows, which require delivery order to be preserved.

- 4a. The old SGSN shall send the **Forward SRNS Context** message (Send N-PDU number, Receive N-PDU number, DL GTP-U number, UL GTP-U number) to the new SGSN if there is at least one PDP context which either requires "delivery order" to be preserved or which uses LLC ABM. The **Forward SRNS Context** message is then acknowledged by the **Forward SRNS Context Acknowledge** message. The forward SRNS message contains the sequence numbers of the GTP-PDU next to transmitted in the uplink and downlink direction and the next N-PDU number that would have been used to send and receive data from the MS.

The N-PDU numbers are only sent by the old SGSN for PDP contexts, which uses LLC ABM. The GTP-U numbers are only sent by the old SGSN for PDP context(s) requiring delivery order (QoS profile) to be preserved. If delivery order is to be preserved (QoS profile), consecutive GTP-PDU sequence numbering shall be maintained through the lifetime of the PDP context(s).

Therefore, during the entire PS Handover procedure for the PDP context(s) using delivery order required (QoS profile), the responsible GTP-U entities (old SGSN, target RNC and GGSN) shall assign consecutive GTP-PDU sequence numbers to user packets belonging to the same PDP context uplink and downlink, respectively.

The target RNC proceed as follows:

- For RABs which require lossless PDCP in the target RNC, the target RNC stores the N-PDUs in the PDCP queue and converts the Send N-PDU number (if present) into a PDCP sequence number by adding eight most significant bits "1".
- For RABs not requiring lossless PDCP the target RNC may, according the QoS profile of the PDP context, store the received data until it receives confirmation of MS presence in the target cell.

The further target RNC/BSS behaviour is as specified in 3GPP TS 23.060 [19] (Combined Hard Handover and SRNS Relocation).

5. The source BSS sends the **PS Handover Command** message containing the **Handover to UTRAN Command** message (as specified in 3GPP TS 25.331 [17]) or **Radio Bearer Reconfiguration** message (as specified in 3GPP TS 44.118 [16]) to the MS by interrupting the transmission of LLC PDUs on any of the downlink TBFs. Following the transmission of this signalling message the source BSS immediately resumes LLC PDU transmission until it either has no more LLC PDUs to send or the PFC is released. MS management of uplink N-PDUs following the reception of the **PS Handover Command** message is as follows:
  - All N-PDUs associated with a PFC receiving handover treatment that have not yet been fully transmitted might be buffered depending on the QoS class.
  - Subsequent uplink N-PDUs that become available for transmission following the reception of the **PS Handover Command** message might also be buffered depending on the QoS class.
  - For real time services uplink N-PDUs may be discarded by the MS during the link interruption.

NOTE 2: Any buffering should be performed before the data is passed to SNDCP in order to avoid header compression on N-PDUs such that data delivery in the target cell may begin from the correct point in the sequence.

6. MS is in the target cell and performs access to UTRAN as defined in 3GPP TS 25.331 [17] and to GERAN Iu mode as defined in 3GPP TS 44.118 [16].
7. Target RNC/BSS sends a **Relocation Detect** message to the new SGSN to indicate that the MS is in the target cell. The message shall be sent when the relocation execution trigger is received. For SRNS relocation type "UE Involved", the relocation execution trigger may be received from the Uu interface; i.e. when the target RNC detects the MS on the lower layers. When the **Relocation Detect** message is sent, the target RNC shall start source RNC operation.
8. In UTRAN, MS sends **Handover to UTRAN Complete** {Message Type, UE Information elements (Start List, CN Domain Identity, Start), RB Information Elements (Count-C Activation Time)} message to the target RNC (see 3GPP TS 25.331 [17]).

In GERAN Iu, MS sends **Radio Bearer Reconfiguration Complete** {RRC Transaction Identifier, Integrity Check Info, Uplink Integrity Protection Activation Info, COUNT-C Activation Time, Radio Bearer Uplink Ciphering Activation Time Info, Mobile Observed Time Difference, Uplink Counter Synchronisation Info struct, START List, CN Domain Identity, START, RB with PDCP Information List, RB with PDCP Information} message to target BSS.

9. When the new source RNC-ID + S-RNTI are successfully exchanged with the MS, the target RNC/BSS shall send the **Relocation Complete** message to the new SGSN. The purpose of the Relocation Complete procedure is to indicate by the target RNC/BSS the completion of the relocation of the source BSS to the CN. After the reception of the **Relocation Complete** message the 3G/2G SGSN shall be prepared to receive data from the target RNC/BSS.
10. The reception of the **Relocation Complete** message in the new SGSN triggers the sending of an **Update PDP Context Request** (new SGSN Address, TEID, QoS Negotiated) message to the GGSN concerned. The GGSN updates the PDP context fields and returns an **Update PDP Context Response** (TEID) message. From now on the GGSN sends new incoming downlink IP packets only to the new SGSN. Each uplink N-PDU received by the new SGSN prior to updating the PDP Context for the associated RAB by the **Update PDP Context Request** message is discarded. Once the new SGSN has updated the PDP Context for any given RAB, it starts sending all associated uplink N-PDUs it receives directly to the GGSN.

11. For inter-SGSN PS handover, the new SGSN sends a **Forward Relocation Complete** message to the old SGSN to indicate the success of the handover procedure. The old SGSN acknowledges this with a **Forward Relocation Complete Acknowledge** message. Upon the reception of the Forward Relocation Complete message the old SGSN starts a packet forwarding timer. The old SGSN stops forwarding of data to the new SGSN after the packet forwarding timer expires.
12. The old SGSN shall initiate PFC Management procedures towards the source cell in order to trigger the release of resources in the source cell.
13. The MS sends a **Routing Area Update Request** (Old RAI, Old P-TMSI signature, Update Type) message to the new SGSN informing it that the source cell belongs to a new routing area. The MS shall send this message immediately after message 7. The new SGSN knows that a handover has been performed for this MS and can therefore exclude the SGSN context procedures which normally are used within the RA Update procedure.
14. At this point the new SGSN may optionally invoke MS authentication (security function). The security function can be deferred and performed at any later time as well.
15. The new SGSN informs the HLR of the change of SGSN by sending **Update Location** (SGSN Number, SGSN Address, IMSI) message to the HLR.
16. The HLR sends **Cancel Location** (IMSI, Cancellation Type) message to the old SGSN with Cancellation Type set to Update Procedure.
17. The old SGSN acknowledges with a **Cancel Location Acknowledge** (IMSI) message. This message allows the old SGSN to know when to release the inter-SGSN tunnel.
18. The HLR sends **Insert Subscriber Data** (IMSI, GPRS subscription data) message to the new SGSN. The new SGSN validates the MS presence in the (new) RA.
19. If all checks are successful then the new SGSN constructs an MM context for the MS and returns an **Insert Subscriber Data Acknowledge** (IMSI) message to the HLR. This message allows the new SGSN to know when to release the inter-SGSN tunnel.
20. The HLR acknowledges the Update Location by sending an **Update Location Acknowledge** (IMSI) message to the new SGSN.
21. The new SGSN validates the MS presence in the new RA. If the MS is allowed to be attached in this RA, the SGSN updates the MM context for and sends a **Routing Area Update Accept** message to the MS.
22. The MS may respond to the SGSN with a **Routing Area Update Complete** message.



## 5.3 Inter-RAT/mode Handover (UTRAN/GERAN Iu → GERAN A/Gb)

### 5.3.1 Intra SGSN

#### 5.3.1.1 Inter RAT/mode UTRAN/GERAN Iu to GERAN A/Gb PS HO; Preparation phase

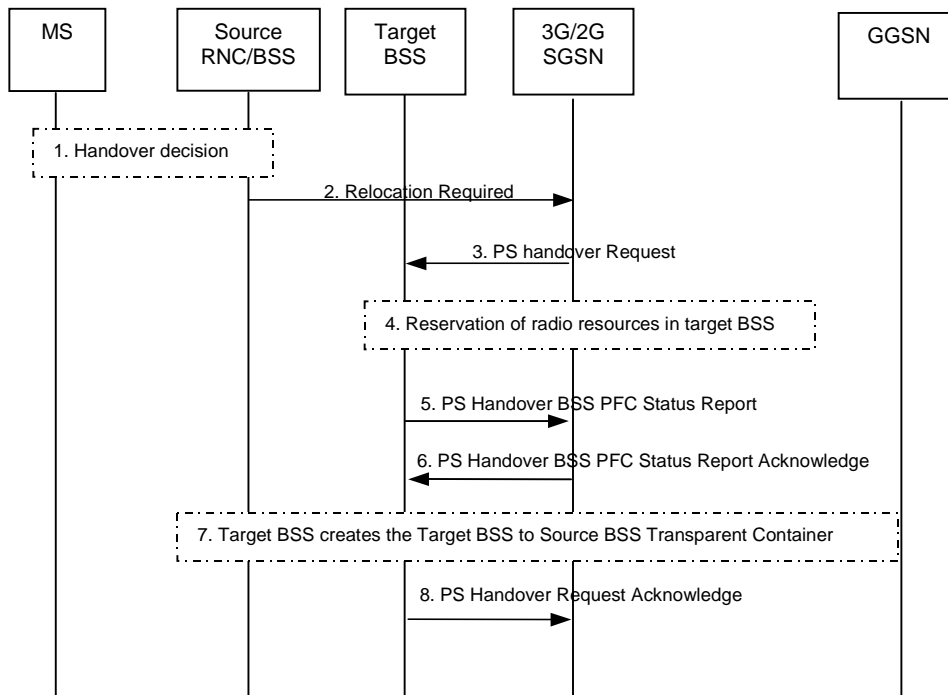

**Figure 15: PS Handover Preparation Phase; Inter-RAT/mode, Intra-SGSN case (UTRAN/GERAN Iu → GERAN A/Gb)**

1. Based on measurement results and knowledge of the RAN topology, the source RNC/BSS decides to initiate an inter RAT/mode PS handover towards the GERAN A/Gb. At this point both uplink and downlink user data flows via the tunnel(s): Radio Bearer between the MS and the source RNC/BSS; GTP-U tunnel(s) between the source RNC/BSS and the 3G/2G SGSN; GTP-U tunnel(s) between the 3G/2G SGSN and the GGSN.

NOTE 1: The process leading to the handover decision is outside of the scope of this paper.

2. The source RNC/BSS sends a **Relocation Required** (Relocation Type, Cause, Source ID, Target ID, MS Classmark 2, MS Classmark 3, Source BSS To Target BSS Transparent Container [RN part]) message to the 3G/2G SGSN. The source RNC/BSS shall set Relocation Type to "UE Involved in relocation of SRNS".

Target ID contains the ID of the target cell BSS.

NOTE 2: The Target ID contains the CGI if GERAN is the target cell. Considering that CGI contains only LAI and CI, it will be problematic for the SGSN to determine the target cell in PS domain without the RAI. The same is valid in case of UTRAN-GERAN PS handover.

3. The 3G/2G SGSN determines from the Target ID the type of handover, i.e. intra-SGSN, inter-SGSN or inter-RAT/mode handover. In case of Inter-RAT/Intra-SGSN PS handover, the 3G/2G SGSN sends a **PS Handover Request** (TLLI, IMSI, Target Cell Identifier, Source BSS to Target BSS Transparent Container [RN part], PFC(s) To Be Set Up List, XiD Command) message to the target BSS. The 3G/2G SGSN shall not request resources for PFCs associated with PDP contexts with a maximum bit rate for uplink and downlink of 0 kbit/s.

4. Based upon the ABQP for each PFC the target BSS makes a decision about which PFCs to assign radio resources. The algorithm by which the BSS decides which PFCs that need resources is implementation specific. Due to resource limitations not all downloaded PFCs will necessarily receive resource allocation. The target BSS allocates TBFs for each PFC that can be accommodated by the target BSS.

NOTE 3: For each N-SAPI associated to a PFC in the PFCs To Be Set Up List, the 3G/2G SGSN shall provide an XID Command.

After allocating radio resources the target BSS shall prepare the Target BSS to Source BSS Transparent Container for the set up BSS PFCs.

5. If the target BSS is not able to allocate resources for one or more BSS PFCs it shall send **PS Handover BSS PFC Status Report** (Set Up PFCs, Failed to Set Up PFCs) message to the 3G/2G SGSN.
6. Upon receiving the **PS Handover BSS PFC Status Report** message the 3G/2G SGSN sends the XID Command for each of the set up PFCs to the target BSS in the **PS Handover BSS PFC Status Report Acknowledge** (XID Command for the set up BSS PFC) message.
7. After receiving all the necessary information for the accepted PFCs the target BSS shall prepare the Target BSS to Source BSS Transparent Container including the XID Commands only for the set up BSS PFCs.
8. The target BSS shall send the **PS Handover Request Acknowledge** message (TLLI, Cause, PFCs Setup, failed PFCs, Target BSS to Source BSS Transparent Container [RN part, CN part]) message to the 3G/2G SGSN for the accepted PFCs. Upon sending the **PS Handover Request Acknowledge** message the target BSS shall be prepared to receive downlink LLC PDUs from the 3G/2G SGSN for the accepted PFCs.

Any PDP contexts for which a PFC was not established will be released.

When the 3G/2G SGSN receives the **PS Handover Request Acknowledge** message and it decides to proceed with the handover, the preparation phase is finished and the execution phase will follow.

5.3.1.2 Inter RAT/mode UTRAN/GERAN Iu to GERAN A/Gb PS HO; Execution phase

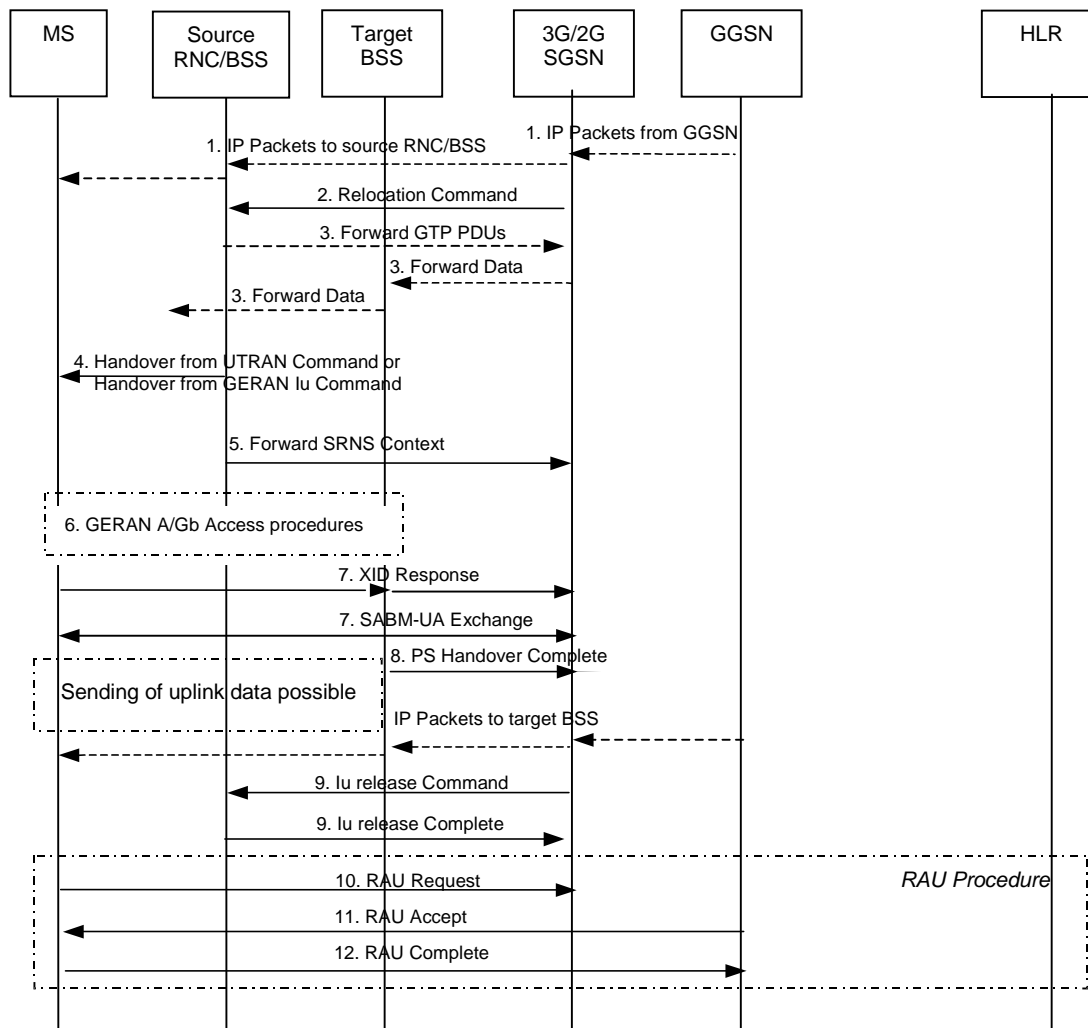

**Figure 16: PS Handover Execution Phase; Inter-RAT/mode, Intra-SGSN case (UTRAN/GERAN Iu → GERAN A/Gb)**

1. The 3G/2G SGSN continues to receive IP packets from the GGSN (via GTP) and forwards the associated PDU payload to the MS via the source RNC/BSS.
2. The 3G/2G SGSN continues the PS handover by sending a **Relocation Command** (Target RNC to Source RNC Transparent Container [RN part, CN part], RABs to be Released List, RABs Subject to Data Forwarding List) message to the source RNC/BSS. "RABs to be released list" will be the list of all NSAPIs (RAB Ids) for which a PFC was not established "RABs Subject to Data forwarding list" will be the list of all NSAPIs (RAB Ids) for which a PFC was established.
3. When receiving the **Relocation Command** message the source RNC may, based on QoS, begin the forwarding of data for the RABs subject to data forwarding to the 3G/2G SGSN according to the definition in 3GPP TS 23.060 [19].

The 3G/2G SGSN may, based on QoS, proceed with the packet handling as follows:

- For PDP contexts, which use LLC ABM the 3G/2G SGSN converts the PDCP sequence number into a Send N-PDU number (this is done by stripping off the 8 most significant bits of the PDCP sequence number) and stores the N-PDU associated with each Send N-PDU number into the SNDSCP queue. Data transfer prior the exchange of N-PDU SNs between MS and 3G/2G SGSN is not possible.
- For PDP contexts which use LLC ADM the 3G/2G SGSN either:

- a. forwards the received downlink N-PDUs to the target BSS;
- b. stores the received data into the SNDCP queue for e.g. the PDU lifetime;
- c. discards the received data until e.g. reception of the **PS Handover Complete** message.

If the 3G/2G SGSN forwards packets to the target BSS, the target BSS may start a blind transmission of downlink user data towards the MS over the allocated radio channels.

4. The RNC/BSS sends the **Handover from UTRAN Command** message (UTRAN) or the **Handover from GERAN Iu Command** message to the MS. Before sending the message the uplink and downlink data transfer shall be suspended in the source RNC for the RABs that require delivery order.
5. The source RNC/BSS continues the handover by sending a **Forward SRNS Context** (RAB contexts) message to the 3G/2G SGSN.  
  
The source RNC/BSS behavior is as specified in 3GPP TS TS 23.060 [19] (Combined Hard Handover and SRNS Relocation).
6. The MS executes the handover according to the parameters provided in the message delivered in step 5. The procedure is the same as in step 6 in clause 5.1.4.2.
7. After accessing the cell using access bursts and receiving timing advance information from the BSS in step 6, the MS immediately sends one **XID Response** (e.g. IOV) message to the 3G/2G SGSN for each **XID Command** message received in the source cell, thereby informing the SGSN about the negotiated security parameters. For LLC ABM, the **XID Response** message is followed by a SABM-UA exchange procedure as defined in TS 44.064. To make the handover interruption short the MS sends this message immediately after receiving the **Physical Information** message or, in the synchronised network case, immediately after the sending of the **PS Handover Access** message.
8. Upon reception of the first correct RLC/MAC block (sent in normal burst format) the target BSS sends a **PS Handover Complete** (TLLI, Handover Complete Status) message to inform the PFM entity in the 3G/2G SGSN that the MS has arrived in the target cell. The source RNC/BSS initiates the release of the radio resources in the source cell. After the reception of the **PS Handover Complete** message the 3G/2G SGSN shall be prepared to receive data from the target BSS.
9. The 3G/2G SGSN sends an **Iu Release Command** message to the source RNC/BSS commanding the source RNC/BSS to release all resources related to the Iu connection. When the RNC/BSS data forwarding timer has expired the source RNC/BSS responds with an **Iu Release Complete** (RAB Data Volume report list, RABs released list) message.
10. The MS sends a **Routing Area Update Request** (Old P-TMSI, Old RAI, Old P-TMSI signature, Update Type) message to the 3G/2G SGSN informing it that the source cell belongs to a new routing area. The MS shall send this message immediately after message 7, see 3GPP TS 23.060 [19].

The 3G/2G SGSN knows that a handover has been performed for this MS and can therefore exclude the SGSN context procedures which normally are used within the RA Update procedure.

11. The 3G/2G SGSN validates the MS presence in the new RA. If the MS is allowed to be attached in this RA, the 3G/2G SGSN updates the MM context for and sends a **Routing Area Update Accept** (P-TMSI, TMSI, P-TMSI signature, Receive N-PDU number) message to the MS. The Receive N-PDU Number contains the acknowledgements for each acknowledged-mode NSAPI used by the 3G/2G SGSN, thereby confirming all mobile originated N-PDUs successfully transferred before the start of the PS handover procedure.

12. The MS confirms the re-allocation of the new P-TMSI by responding the 3G/2G SGSN with a **Routing Area Update Complete** (Receive N-PDU number). The MS derives the TLLI from the new P-TMSI using the current MM procedures. The Receive N-PDU Number contains the acknowledgements for each acknowledged mode NSAPI used by the MS, thereby confirming all mobile terminated N-PDUs successfully transferred before the start of the handover procedure. If Receive N-PDU Number confirms reception of N-PDUs that were forwarded from the 3G/2G SGSN, these N-PDUs shall be discarded by the 3G/2G SGSN.

## 5.3.2 Inter SGSN

### 5.3.2.1 Inter RAT/mode UTRAN/GERAN Iu to GERAN A/Gb PS HO; Preparation phase

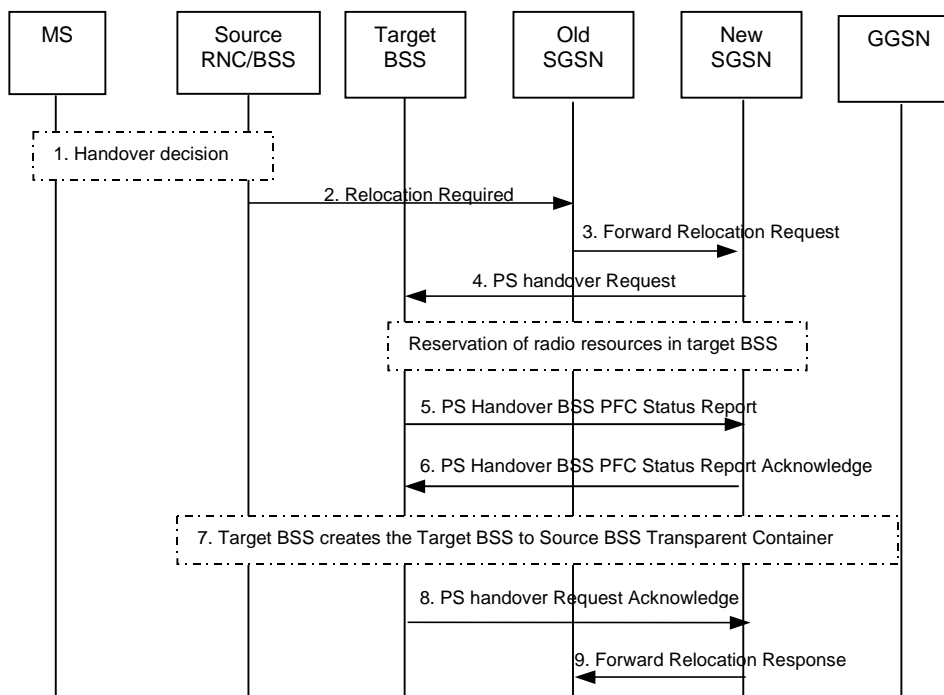

**Figure 17: PS Handover Preparation Phase; Inter-RAT/mode, Inter-SGSN case (UTRAN/GERAN Iu → GERAN A/Gb)**

- Based on measurement results and knowledge of the RAN topology, the source RNC/BSS decides to initiate an inter RAT/mode PS handover towards the GERAN A/Gb. At this point both uplink and downlink user data flows via the tunnel(s): Radio Bearer between the MS and the source RNC/BSS; GTP-U tunnel(s) between the source RNC/BSS and the old SGSN; GTP-U tunnel(s) between the old SGSN and the GGSN.

NOTE 1: The process leading to the handover decision is outside of the scope of this paper.

- The source RNC/BSS sends a **Relocation Required** (Relocation Type, Cause, Source ID, Target ID, MS Classmark 2, MS Classmark 3, Source BSS To Target BSS Transparent Container [RN part]) message to the old SGSN. The source RNC/BSS shall set Relocation Type to "UE Involved in relocation of SRNS".

Target ID contains the ID of the target cell BSS.

NOTE 2: The Target ID contains the CGI if GERAN is the target cell. Considering that CGI contains only LAI and CI, it will be problematic for the SGSN to determine the target cell in PS domain without the RAI. The same is valid in case of UTRAN-GERAN PS handover.

- The old SGSN determines from the Target ID the type of handover, i.e. intra-SGSN, inter-SGSN or inter-RAT/mode handover. In case of Inter-RAT/Inter-SGSN PS handover, the old SGSN initiates the PS Handover resource allocation procedure by sending a **Forward Relocation Request** (IMSI, TEI Control Plane, RANAP Cause, MM Context, PDP Contexts, PDP Context Prioritisation, Source BSS To Target BSS Transparent Container [RN part], Target Identification, SGSN Address for control plane) message to the new SGSN.

As part of the MM context the following security related information is included:

- CK UMTS Ciphering Key.
- IK UMTS Integrity protection Key.
- KSI Key Set Identifier.
- MS Network Capability Includes ciphering algorithms supported by the MS.

The value for Kc (Ciphering key for GPRS) is calculated from the CK and IK and the CKSN (Ciphering Key Sequence Number of Kc) takes the same value as KSI.

The new SGSN selects the ciphering algorithm to use. This algorithm will be sent transparently from the new SGSN to the MS. The IOV-UI parameter generated in the new SGSN and used, as input to the ciphering procedure will also be transferred transparently from the new SGSN to the MS.

When the new SGSN receives the **Forward Relocation Request** message the required PDP, MM, SNDCP and LLC contexts are established and a new P-TMSI is allocated for the MS. The mapping between N-SAPI, SAPI and PFI for each PDP Context which is established and provided to the target BSS. When this message is received by the new SGSN it begins the process of establishing PFCs for all PDP contexts.

When the new SGSN receives the Forward Relocation Request message it extracts from the PDP Contexts the NSAPIs and possibly the SAPIs to be used in the new SGSN. If no SAPI was available at the old SGSN for a certain NSAPI, the new SGNS shall assign a SAPI and the PFI for this NSAPI. In this case the mapping between N-SAPI, SAPI and PFI for each PDP Context which is established and provided to the target BSS.

In case when an SAPI and PFI was available at the old SGSN but the new SGSN does not support the same SAPI and PFI for a certain NSAPI as the old SGSN, the new SGSN shall continue the PS handover procedure only for those NSAPIs for which it can support the same PFI and SAPI as the old SGSN. All PDP contexts for which no resources are allocated by the new SGSN or for which it cannot support the same SAPI and PFI (i.e. the corresponding NSAPIs are not addressed in the response message of the target SGSN), are maintained and the related SAPIs and PFIs are kept. These PDP contexts may be modified or deactivated by the new SGSN via explicit SM procedures upon RAU procedure.

When the new SGSN receives the Forward Relocation Request message the required PDP, MM, SNDCP and LLC contexts are established.

NOTE 3: In this case XID parameters are not sent from the old SGSN to the new SGSN.

The new SGSN shall for a given N-SAPI:

- send an XID Command indicating the new XID parameters and new IOVs to the target BSS; or
- send an XID Command indicating Reset and new IOVs to the target BSS.

NOTE 4: The handling of XID negotiation is as specified in 3GPP TS 44.064 [21].

4. The new SGSN sends a **PS Handover Request** (Local TLLI, IMSI, Target Cell Identifier, Source BSS to Target BSS Transparent Container [RN part], PFC(s) To Be Set Up List, XiD Command) message to the target BSS. The new SGSN shall not request resources for PFCs associated with PDP contexts with maximum bit rate for uplink and downlink of 0 kbit/s.

NOTE 5: For each N-SAPI associated to a PFC in the PFCs To Be Set Up List, the new SGSN shall provide an XID Command.

Based upon the ABQP for each PFC the target BSS makes a decision about which PFCs to assign radio resources. The algorithm by which the BSS decides which PFCs that need resources is implementation specific.

5. If the target BSS is not able to allocate resources for one or more BSS PFCs it shall send **PS Handover BSS PFC Status Report** (Setup PFC, Failed to Set Up PFCs) message to the new SGSN.
6. Upon receiving the **PS Handover BSS PFC Status Report** message the new SGSN sends the XID Command for each of the set up PFCs to the target BSS in the **PS Handover BSS PFC Status Report Acknowledge** (XID Command for the set up BSS PFC) message.

7. After receiving all the necessary information for the accepted PFCs the target BSS shall prepare the Target BSS to Source BSS Transparent Container including the XID Commands only for the set up BSS PFCs.
8. Target BSS shall send the **PS Handover Request Acknowledge** message (Local TLLI, Cause, PFCs Setup, failed PFCs, Target BSS to Source BSS Transparent Container [RN part, CN part]) message to the new SGSN for the accepted PFCs. Upon sending the **PS Handover Request Acknowledge** message the target BSS shall be prepared to receive downlink LLC PDUs from the new SGSN for the accepted PFCs.

Any PDP contexts for which a PFC was not established will be released.

9. The new SGSN passes the assigned list of TEIDs for each PDP context for which a PFC was assigned in the RAB setup information IE in the **Forward Relocation Response** (Cause, Target BSS to Source BSS Transparent Container [RN part, CN part]), Tunnel Endpoint Identifier Data II) message to the old SGSN. The Tunnel Endpoint Identifier Data II, one information for each PDP context, contains the tunnel endpoint of the new SGSN and the IP address of the new SGSN for data forwarding from the SRNC to the new SGSN.

When the old SGSN receives the **Forward Relocation Response** message and it decides to proceed with the handover, the preparation phase is finished and the execution phase will follow.

5.3.2.2 Inter RAT UTRAN/GERAN Iu to GERAN A/Gb PS HO; Execution phase

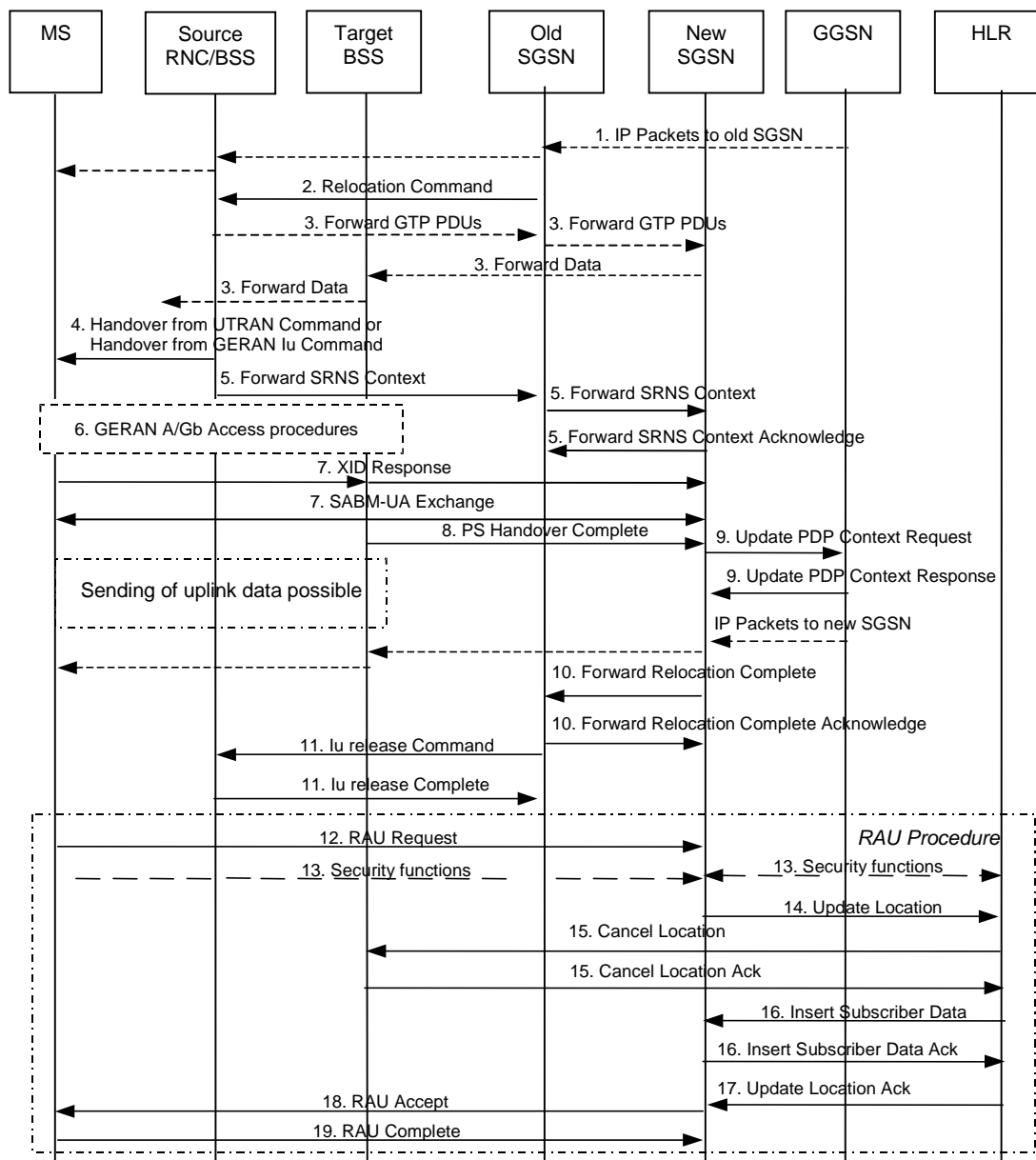

**Figure 18: PS Handover Execution Phase; Inter-RAT/mode, Inter-SGSN case (UTRAN/GERAN Iu → GERAN A/Gb)**

1. The old SGSN continues to receive IP packets from the GGSN (via GTP) and forwards the associated PDU payload to the MS via the source RNC/BSS.
2. The old SGSN continues the PS handover by sending a **Relocation Command** (Target RNC to Source RNC Transparent Container [RN part, CN part], RABS to be Released List, RABS Subject to Data Forwarding List) message to the source RNC/BSS. "RABS to be released list" will be the list of all NSAPIs (RAB Ids) for which a PFC was not established "RABS Subject to Data forwarding list" will be the list of all NSAPIs (RAB Ids) for which a PFC was established.
3. When receiving the **Relocation Command** message the source RNC/BSS may, based on QoS, begin the forwarding of data for the RABS subject to data forwarding to the new SGSN according to the definition in 3GPP TS 23.060 [19].



The new SGSN may, based on QoS, proceed with the packet handling as follows:

- For PDP contexts, which use LLC ABM the new SGSN converts the PDCP sequence number into a Send N-PDU number (this is done by stripping off the 8 most significant bits of the PDCP sequence number) and stores the N-PDU associated with each Send N-PDU number into the SNDCP queue. Data transfer prior the exchange of N-PDU SNs between MS and new SGSN is not possible.
- For PDP contexts which use LLC ADM the new SGSN either:
  - a. forwards the received downlink N-PDUs to the target BSS;
  - b. stores the received data into the SNDCP queue for e.g. the PDU lifetime;
  - c. discards the received data until e.g. reception of the **PS Handover Complete** message.

If the new SGSN forwards packets to the target BSS, the target BSS may start a blind transmission of downlink user data towards the MS over the allocated radio channels.

NOTE: The order of steps, starting from step 3 onwards, does not necessarily reflect the order of events. For instance the source RNC may start data forwarding (step 3), send the RRC message (step 5) and send the **Forward SRNS Context** message (step 5a) almost simultaneously.

4. The source RNC/BSS sends the **Handover from UTRAN Command** message (UTRAN) or the **Handover from GERAN Iu Command** message to the MS. Before sending the message the uplink and downlink data transfer shall be suspended in the source RNC for the RABs that require delivery order.

The PS handover structure encapsulated in this message shall contain for each of the NSAPI for which resources are allocated the allocated PFI if the SAPI was available at the old SGSN and the allocated SAPI and PFI, if no SAPI and PFI was available at the old SGSN. The MS utilizes the newly assigned SAPI and PFI values for a certain NSAPI in the target cell. Upon reception of the **Handover from UTRAN Command** message (UTRAN) or the **Handover from GERAN Iu Command** the MS shall suspend the uplink transmission of user plane data.

5. The source RNC continues the handover by sending a **Forward SRNS Context** (RAB contexts) message to the new SGSN, via the old SGSN. The **Forward SRNS Context** message is acknowledged by the new SGSN with the **Forward SRNS Context Acknowledge** message to the old SGSN.

The source RNC/BSS behavior is as specified in 3GPP TS 23.060 [19] (Combined Hard Handover and SRNS Relocation).

6. The MS executes the handover according to the parameters provided in the message delivered in step 5. The procedure is the same as in step 6 in clause 5.1.4.2 with the additional function of association of the received SAPI and PFI and existing RAB Id to the particular NSAPI as described in clause 4.4.1.
7. After accessing the cell using access bursts and receiving timing advance information from the BSS in step 6, the MS immediately sends one **XID Response** (e.g. IOV) message to the new SGSN for each XID Command message received in the source cell, thereby informing the SGSN about the negotiated security parameters. For LLC ABM, the **XID Response** message is followed by a SABM-UA exchange procedure as defined in TS 44.064. To make the handover interruption short the MS sends this message immediately after receiving the **Physical Information** message or, in the synchronised network case, immediately after the sending of the **PS Handover Access** message.

Upon successful XID negotiation the MS shall resume the user data transfer only for those NSAPIs for which there are radio resources allocated in the target cell. All other NSAPIs shall be handled following the legacy procedures during routing area change, thus the MS shall not resume the uplink user data transfer until the routing area update procedure is completed.

8. Upon reception of the first correct RLC/MAC block (sent in normal burst format) the target BSS sends a **PS Handover Complete** (Local TLLI, Handover Complete Status) message to inform the PFM entity in the new SGSN that the MS has arrived in the target cell. The source RNC/BSS initiates the release of the radio resources in the source cell. After the reception of the **PS Handover Complete** message the new SGSN shall be prepared to receive data from the target BSS.

9. The new SGSN sends an **Update PDP Context Request** (new SGSN Address, TEID, QoS Negotiated) message to the GGSN concerned. The GGSN updates the PDP context fields and returns an **Update PDP Context Response** (TEID) message. From now on the GGSN sends new incoming downlink IP packets only to the new SGSN. Each uplink N-PDU received by the new SGSN prior to updating the PDP Context for the associated PFC by the **Update PDP Context Request** message is discarded. Once the new SGSN has updated the PDP Context for any given PFC, it starts sending all associated uplink N-PDUs it receives directly to the GGSN.
10. The new SGSN send a **Forward Relocation Complete** message to the old SGSN to indicate completion of the PS handover procedures. The old SGSN responds with a **Forward Relocation Complete Acknowledge** message.
11. The old SGSN sends an **Iu Release Command** message to the source RNC/BSS commanding the source RNC/BSS to release all resources related to the Iu connection. When the RNC/BSS data forwarding timer has expired the source RNC/BSS responds with an **Iu Release Complete** (RAB Data Volume report list, RABs released list) message.
12. The MS sends a **Routing Area Update Request** (Old P-TMSI, Old RAI, Old P-TMSI signature, Update Type) message to the new SGSN informing it that the source cell belongs to a new routing area. The MS shall send this message immediately after message 7, see 3GPP TS 23.060 [19].

The new SGSN knows that a handover has been performed for this MS and can therefore exclude the SGSN context procedures which normally are used within the RA Update procedure.

13. At this point the new SGSN may optionally invoke MS authentication (security function). The security function can be deferred and performed at any later time as well.
14. The new SGSN informs the HLR of the change of SGSN by sending **Update Location** (SGSN Number, SGSN Address, IMSI) message to the HLR.
15. The HLR sends a **Cancel Location** (IMSI, Cancellation Type) message to the old SGSN with Cancellation Type set to Update Procedure. The old SGSN acknowledges with a **Cancel Location Acknowledge** (IMSI) message. This message allows the old SGSN to know when to release the inter-SGSN tunnel.
16. The HLR sends **Insert Subscriber Data** (IMSI, GPRS subscription data) message to the new SGSN. The new SGSN validates the MS presence in the (new) RA. If all checks are successful then the new SGSN constructs an MM context for the MS and returns an **Insert Subscriber Data Acknowledge** (IMSI) message to the HLR. This message allows the new SGSN to know when to release the inter-SGSN tunnel.
17. The HLR acknowledges the Update Location by sending an **Update Location Acknowledge** (IMSI) message to the new SGSN.
18. The new SGSN validates the MS presence in the new RA. If the MS is allowed to be attached in this RA, the SGSN updates the MM context for and sends a **Routing Area Update Accept** (P-TMSI, TMSI, P-TMSI signature, Receive N-PDU number) message to the MS. The Receive N-PDU Number contains the acknowledgements for each acknowledged-mode NSAPI used by the SGSN, thereby confirming all mobile originated N-PDUs successfully transferred before the start of the PS handover procedure.
19. The MS confirms the re-allocation of the new P-TMSI by responding the SGSN with a **Routing Area Update Complete** (Receive N-PDU number). The MS derives the Local TLLI from the new P-TMSI using the current MM procedures. The Receive N-PDU Number contains the acknowledgements for each acknowledged mode NSAPI used by the MS, thereby confirming all mobile terminated N-PDUs successfully transferred before the start of the handover procedure. If Receive N-PDU Number confirms reception of N-PDUs that were forwarded from the old SGSN, these N-PDUs shall be discarded by the new SGSN.

## 5.4 Handover reject

### 5.4.1 General

The target BSS may reject the use of the PS Handover procedure in case it cannot allocate resources for any of the PFCs requested in the **PS Handover Request** message. In this case no MS context will be established in the target BSS and no resources will be allocated. The target BSS will send a **PS Handover Reject** message to the new SGSN causing the new SGSN to release any allocated resources (e.g. P-TMSI, MS associated contexts) related to the specific MS. The signalling procedure for the Inter-SGSN HO Reject is shown in clause 5.3.4.5.2. Similar procedures are used in the other handover cases.

### 5.4.2 Inter-SGSN HO Reject; Signalling procedure

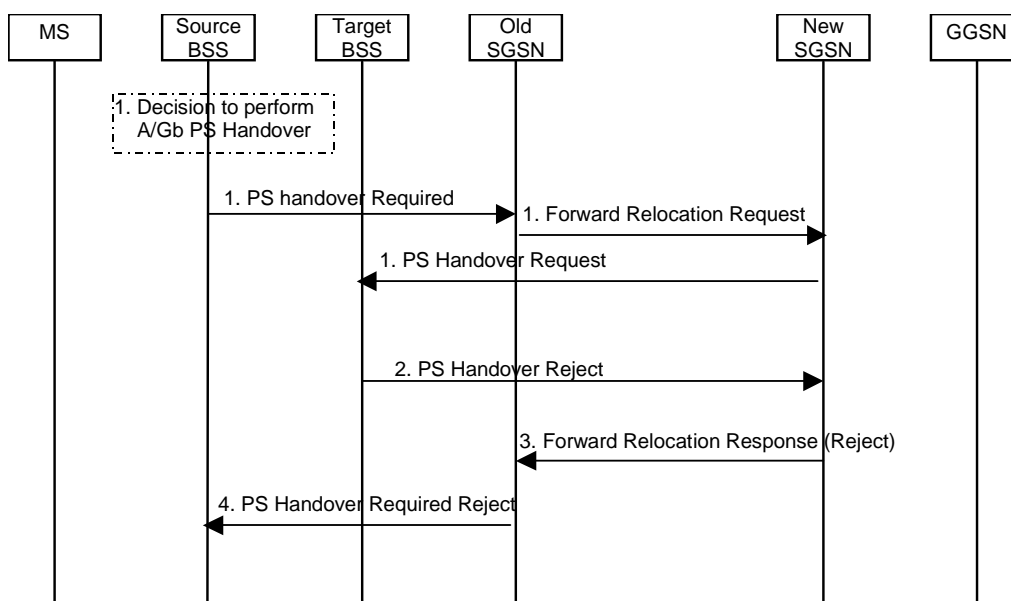

Figure 19: PS Handover Reject; Inter-SGSN case (GERAN A/Gb → GERAN A/Gb)

1. The first four steps in the flow are identical to the ones in clause 5.1.4.1.
2. In case the target BSS fails to allocate any resources for any of the requested PFCs it sends a **PS Handover Reject** (Cause, Source Cell Identifier, Target Cell Identifier) message to the new SGSN.
3. When the new SGSN receives the **PS Handover Request Reject** message it clears any reserved resources (e.g. PDP context, P-TMSI) for this mobile and sends the **Forward Relocation Response** (IMSI, Cause, Source Cell Identifier, Target Cell Identifier, SGSN Address) message to the old SGSN.
4. When the old SGSN receives the **Forward Relocation Response** message it sends a **PS Handover Required Reject** (Old TLLI, Cause, Source Cell Identifier, Target Cell Identifier) message to the source BSS.

## 5.5 Handover cancel

### 5.5.1 General

Instead of performing the handover, the source BSS may at any time during the handover procedure up to the time when the PS Handover Command is sent to the mobile station cancel the handover. The reason for canceling can be e.g. due to a timer expiration or due to other events within the source BSS and is initiated by sending a **PS Handover Cancel** message to the SGSN.

A **PS Handover Cancel** message shall also be sent by the source BSS after the **PS Handover Command** message is sent to the mobile station for the case where the PS Handover fails and the MS returns to the old cell. This is done in order to release the resources reserved for the PS Handover in the target system.

The signalling procedure for the Inter-RAT Handover Cancellation is shown in clause 5.3.4.5.2. Similar procedures are used in the other handover cases.

## 5.5.2 Inter-RAT Cancellation; Signalling procedure

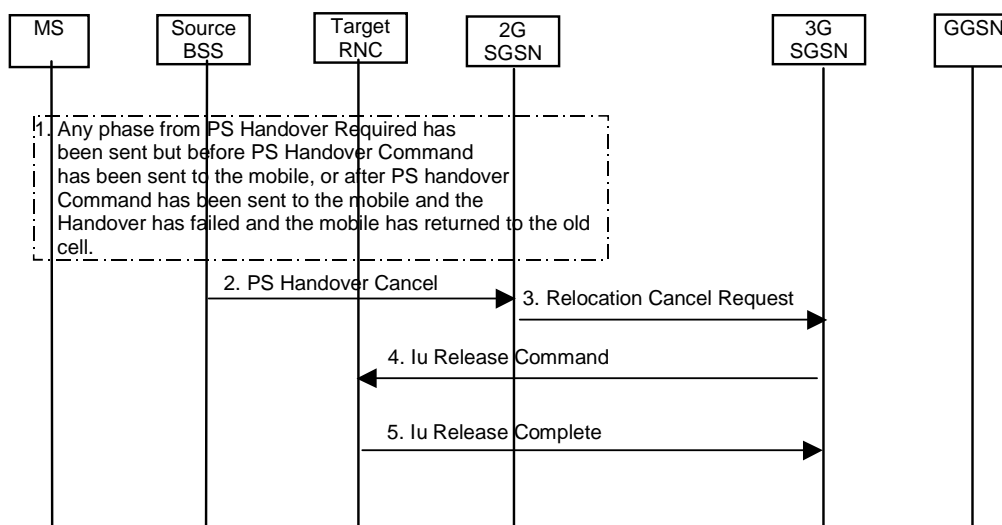

**Figure 20: PS Handover Cancel; Inter-RAT case (GERAN → UTRAN)**

1. The source BSS decides to cancel the previously requested PS handover. This may be due to failed coordination with the CS domain, not enough accepted PFCs, dropped mobile, that the source has requested several target cells simultaneously or any other reason.
2. The source BSS sends a **PS Handover Cancel** (TLLI, Source Cell Identifier, Target ID) message to the old SGSN.
3. The old SGSN terminates the PS Handover to the target cell by sending a **Relocation Cancel Request** (IMSI) message to the new SGSN.

NOTE 1: If one new SGSN was chosen among a pool, then the **Abort** message is sent to the same SGSN.

4. The new SGSN clears the reserved resources in the target cell by sending an **Iu Release Command** (Cause) message to the target RNC.

NOTE 2: In case of GERAN A/Gb to GERAN A/Gb handover it is assumed that existing BSS Packet Flow procedures could be used to clear all reserved resources and MS context in the target BSS.

5. After all resources are cleared, the target RNC shall send the **Iu Release Complete** (RAB Data Volumes, RABs released) message to the new SGSN.

## 5.6 Container handling

There are two transparent containers defined for the PS handover in GERAN A/Gb mode:

- Source BSS to Target BSS Transparent Container.
- Target BSS to Source BSS Transparent Container.

The Source BSS to Target BSS Transparent Container will carry the information to be transported transparently between the source BSS and the target BSS related to PS handover.

The Target BSS to Source BSS Transparent Container will carry the information to be transported transparently between the target BSS and the source BSS related to PS handover.

In case of the inter-RAT/mode PS handover the transparent containers defined for UTRAN/GERAN Iu mode (Source RNC to Target RNC Transparent Container and Target RNC to Source RNC Transparent Container) will be utilized and enhanced with new information elements to support PS handover.

The generic handling of the source cell (GERAN A/Gb mode or UTRAN/GERAN Iu mode) to target cell (GERAN A/Gb mode or UTRAN/GERAN Iu mode) radio-related container is as follows:

- Created by the source BSS or RNC.
- Processed by the target BSS or RNC.
- Forwarded transparently by the SGSNs.

The generic handling of the target cell (GERAN A/Gb mode or UTRAN/GERAN Iu mode) to source cell (GERAN A/Gb mode or UTRAN/GERAN Iu mode) radio-related container is as follows:

- Created by the target BSS or RNC.
- Processed by the source BSS or RNC.
- Forwarded transparently by the SGSNs.

## 5.6.1 Contents of the containers

The transparent container will consist of two parts:

- The **Radio Network part** (RN part) carrying radio interface related parameters relevant for the MS and the radio network (BSS/RNC) and sent transparently through the core network; This content is:
  - Created by the source BSS/RNC or target BSS/RNC.
  - Processed by the target BSS/RNC, source BSS/RNC and MS (reverse container only).
- The **Core Network part** (CN part) carrying parameters relevant for the MS and the core network. This part is only needed from the new SGSN to the MS, thus in the Target BSS to Source BSS Transparent Container. This content is:
  - Created by the new SGSN.
  - Included in the Target BSS to Source BSS Transparent Container by the target BSS.

NOTE 1: The target BSS does not process the Core Network part.

- Forwarded transparently by the old SGSN and source BSS/RNC.
- Processed by the MS.

The contents of the Radio Network part will depend on:

- Type of channels that are subject to PS handover, i.e. shared or dedicated.

NOTE 2: Currently dedicated channels are not considered in the PS handover in GERAN A/Gb mode.

- PS handover scenario, i.e. intra-mode or inter-RAT/mode.

The contents of the Core Network part will depend on the PS handover scenario, i.e. intra-mode or inter-RAT/mode.

### 5.6.1.1 Contents of the GERAN A/Gb mode → GERAN A/Gb Transparent Containers

#### 5.6.1.1.1 Source BSS to Target BSS Transparent Container

In GERAN A/Gb mode → GERAN A/Gb mode the Source BSS to Target BSS Transparent Container is sent in the PS **Handover Required**, **Forward Relocation Request** message and the **PS Handover Request** message.

The Radio Network part consists of the following:

- MS RAC.
- START\_PS and UE RAC (for dual mode mobile stations).

NOTE 1: The START\_PS and UE RAC are needed to support PS Handover to UTRAN/GERAN Iu mode.

NOTE 2: The procedure to get the START\_PS and UE RAC values from the MS to the BSS needs to be defined.

#### 5.6.1.1.2 Target BSS to Source BSS Transparent Container

In GERAN A/Gb mode -> GERAN A/Gb mode the Target BSS to Source BSS Transparent Container is sent in the **PS Handover Request Acknowledge** message, **Forward Relocation Response** message and the **PS Handover Command** message.

The Radio Network part consists of the required information for access in the target cell and the information on allocated radio resources, uplink and downlink TBF parameters, PS Handover reference and generic parameters for access in the target cell (i.e. GPRS cell options, target cell "Cell Selection struct", global power control parameters, reference frequency lists, cell allocation, GPRS mobile allocation).

The Core Network part consists of the XID Commands for the BSS PFCs set up in the target BSS.

#### 5.6.1.2 Contents of the GERAN A/Gb mode → UTRAN Transparent Containers

##### 5.6.1.2.1 Source RNC to Target RNC Transparent Container

In GERAN A/Gb mode -> UTRAN the Source RNC to Target RNC Transparent Container is sent from the source BSS to the target RNC in the **PS Handover Required** message and the **Relocation Request** message.

The Radio Network part consists of the following:

- RRC Container as defined in 3GPP TS 25.331 [17] will contain Inter RAT Handover Info (UTRAN specific information including START\_PS/UE RAC) and Inter RAT UE radio access capability including MS RAC from BSS to RNC.

NOTE: START\_PS and MS RAC are currently not included in this RRC container. This thus needs to be added in 3GPP TS 25.331 [17].

- Target Cell Id.

##### 5.6.1.2.2 Target RNC to Source RNC Transparent Container

In GERAN A/Gb mode -> UTRAN the Target RNC to Source RNC Transparent Container is sent from the target RNC to the source BSS in the **Relocation Request Acknowledge** message, **Forward Relocation Response** message and the **PS Handover Command** message.

The Radio Network part consists of the RRC message, i.e. the **Handover to UTRAN Command** message (as defined in 3GPP TS 25.331 [17]) used to perform handover from GERAN A/Gb mode to UTRAN. This message will be sent to the MS/UE within the **PS Handover Command** message.

#### 5.6.1.3 Contents of the UTRAN → GERAN A/Gb Mode Transparent Containers

##### 5.6.1.3.1 Source BSS to Target BSS Transparent Container

In UTRAN -> GERAN A/Gb mode the Source BSS to Target BSS Transparent Container is sent from the source RNC to the target BSS in the **Relocation Required**, **Forward Relocation Request** message and the **PS Handover Request** message in order to support inter-RAT PS handover from UTRAN (CELL\_DCH state or CELL\_FACH state, only PS RABs established) to GERAN A/Gb mode.

The Radio Network part consists of the following information:

- MS RAC.
- INTER RAT HANDOVER INFO (defined in 3GPP TS 25.331) containing the START\_PS and UE RAC values.

#### 5.6.1.3.2 Target BSS to Source BSS Transparent Container

In UTRAN -> GERAN A/Gb mode the Target BSS to Source BSS Transparent Container is sent from the target BSS to the source RNC in the **PS Handover Request Acknowledge** message, **Forward Relocation Request** message and the **Relocation Command** message in order to support inter-RAT PS handover from UTRAN (CELL\_DCH state or CELL\_FACH state, only PS RABs established) to GERAN A/Gb mode.

The Radio Network part consist of the required information for access in the target cell and the information on allocated radio resources: uplink and downlink TBF parameters, PS Handover reference and generic parameters for access in the target cell (i.e. GPRS cell options, target cell "Cell Selection struct", global power control parameters, reference frequency lists, cell allocation, GPRS mobile allocation). Over the air interface this radio network container is sent within the **Handover from UTRAN Command** message.

The Core Network part consist of the following:

- XID Command for the PDP Contexts for which the BSS PFCs are set up in the target BSS.
- The associated SAPI and PFI for each NSAPI.

#### 5.6.1.4 Contents of the GERAN A/Gb mode → GERAN Iu mode Transparent Containers

##### 5.6.1.4.1 Source RNC to Target RNC Transparent Container

In GERAN A/Gb mode -> GERAN Iu mode the Source RNC to Target RNC Transparent Container is sent from the source BSS to the target BSS (Iu) in the **PS Handover Required** message, **Forward Relocation Request** message and the **Relocation Request** message.

The Radio Network part consists of:

- RRC Container as defined in 3GPP TS 44.118 [16] shall contain START\_PS /MS GERAN IU capabilities.
- Target Cell Id.

##### 5.6.1.4.2 Target RNC to Source RNC Transparent Container

In GERAN A/Gb mode -> GERAN Iu mode the Target RNC to Source RNC Transparent Container is sent from the target BSS (Iu) to source BSS in the **Relocation Request Acknowledge** message, **Forward Relocation Response** message and the **PS Handover Command** message.

The Radio Network Part consist of the RRC message used in GERAN Iu mode to perform handover, i.e. **Radio Bearer Reconfiguration** message as defined in 3GPP TS 44.118 [16]. This message will be sent to the MS in the **PS Handover Command** message.

#### 5.6.1.5 Content of GERAN Iu mode → GERAN A/Gb mode Transparent Containers

##### 5.6.1.5.1 Source BSS to Target BSS Transparent Container

In GERAN Iu mode -> GERAN A/Gb mode the Source BSS to Target BSS Transparent Container is sent from the source BSS (Iu) to the target BSS in the **Relocation Required** message, **Forward Relocation Request** message and the **PS Handover Request** message.

The Radio Network part consists of the following:

- MS RAC.
- INTER RAT OR MODE HANDOVER INFO with MS capabilities as defined in 3GPP TS 44.118 [16].

NOTE: START\_PS and UE RAC shall be added to this IE.

#### 5.6.1.5.2 Target BSS to Source BSS Transparent Container

In GERAN Iu mode -> GERAN A/Gb mode the Target BSS to Source BSS Transparent Container is sent from the target BSS to the source BSS (Iu) in the **PS Handover Response** message, **Forward Relocation Request** message and the **Relocation Command** message in order to support PS handover to GERAN A/Gb mode from GERAN Iu mode (RRC Cell\_Dedicated state or RRC CELL\_Shared state, only PS RABs established).

The Radio Network part consists of the required information for access in the target cell and the information on allocated radio resources: Uplink and downlink TBF parameters, PS Handover reference and generic parameters for access in the target cell (i.e. GPRS cell options, target cell "Cell Selection struct", global power control parameters, reference frequency lists, cell allocation, GPRS mobile allocation). Over the air interface this information is sent in the **Handover from GERAN Iu mode Command** message.

The Core Network part consists of the following:

- XID Command for the PDP Contexts for which the BSS PFCs are set up in the target BSS.
- the associated SAPI and PFI for each NSAPI.

## 5.7 PS Handover Failure

During the PS handover procedure several types of failures can be identified. The PS handover failures may be typical network and signalling failure occurrences such as failures related to the loss of signalling messages, incorrect information element in the signalling messages or failures due to network nodes failures or specific to abnormal cases occurring during PS handover procedures.

In general the PS handover failures can be divided into:

- Preparation Phase Failure Scenarios on the Um, Gb and Gn interface.
- Execution Phase Failure Scenarios on the Um, Gb and Gn interface.

NOTE: RAU procedure failures will be handled as specified in 3GPP TS 24.008 [15].

A list of appropriate cause values should be chosen/defined to indicate to the source cell and target cell nodes the cause of the **PS Handover Reject** and the **PS handover Cancel** messages.

### 5.7.1 Preparations Phase Failure Scenarios

#### 5.7.1.1 PS Handover preparation phase failure scenarios on the Um interface

- No Resource Reservation / Allocation:
  - No radio resources available in the target cell (see clause 5 in 3GPP TS 43.129 [24]).
- Generic Causes:
  - Generic causes, described and handled as defined in 3GPP TS 44.060 [7], for example failure in sending the **Packet Cell Change Failure** message from the MS to the source BSS.

#### 5.7.1.2 PS Handover preparation phase failure scenarios on the Gb interface

- No Resource Reservation / Allocation on the target system:
  - No radio resources available in the target cell (see clause 5.4). Appropriate cause values are needed in the **PS Handover Reject** message.
- Insufficient resource allocation by the target system:



- In case of insufficient resource allocation by the target side the source BSS may cancel the PS handover procedure (see clause 5.5).
- Feature "PS Handover" not supported:
  - A new cause value is needed for the Gb interface if the target BSS does not support the PS Handover procedure.
- Generic Causes:
  - Generic causes for the Gb interface failures are defined in 3GPP TS 48.018 [10]. The same cause values are applicable to the PS handover procedure on the Gb interface.

### 5.7.1.3 PS Handover preparation phase failure scenarios on the Gn interface

- Context Transfer Failure:
  - Context transfer failure may occur due to various causes defined in 3GPP TS 29.060 [11]. These cause values will be utilized during PS handover procedure. These values are to be utilized during PS handover procedure to indicate to the old SGSN the cause of the PS handover reject. Consequently an appropriate cause value should be chosen to allow the old SGSN to indicate to the source BSS the cause of failure.
- No Resource Reservation/ No Resource Allocation:
  - Resource Reservation/Allocation failure occurs when no radio resources are available in the target cell. Consequently an appropriate cause value should be chosen to allow the old SGSN to indicate to the source BSS the cause of failure.
- Procedure "PS Handover" not supported:
  - This occurs when the new SGSN does not support the PS Handover feature.
- Generic Causes:
  - In 3GPP TS 29.060 [11] a set of cause values are defined. The same cause values are applicable to the PS handover procedure on the Gn interface.

## 5.7.2 Execution Phase Failure Scenarios

### 5.7.2.1 Execution phase failures on the Um interface

- Initial Access Failure in the Target Cell during PS handover:
  - In case of initial access failure in the target cell, the MS is allowed to revert to the old cell. As is defined currently in 3GPP TS 44.060 [7], the MS shall return to the old cell and send a **Packet Cell Change Failure** message with the appropriate cause. If the MS was involved in simultaneous uplink and downlink packet transfer mode (or MAC-shared state) before the attempted handover it will, when going back to the old cell, send a **Packet Cell Change Failure** message and continue its uplink transfer. The source BSS will inform the old SGSN about this failure and consequently the old SGSN will inform the new SGSN about this failure, upon which the new SGSN will release the allocated resources and clear out any information and buffers related to this MS.
- Synchronization Failure in the Target Cell:
  - This failure may occur during the ongoing PS Handover procedure due to MS failure to acquire time alignment information (for the unsynchronised network case). In this case the MS goes back to the old cell as described above.
  - The signalling flow for this procedure is depicted in figure 21.

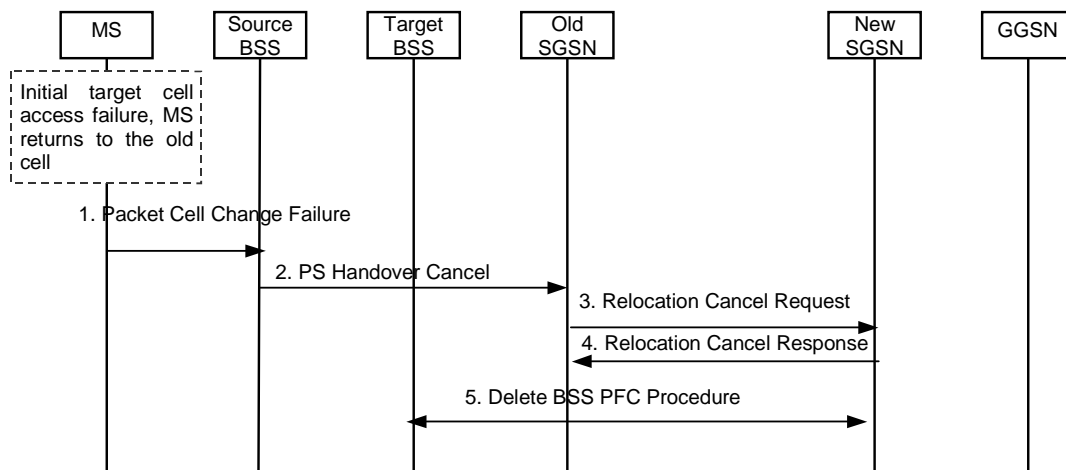

Figure 21: Initial target cell access failure; Inter-SGSN case

### 5.7.2.2 Execution phase failures on the Gb interface

- Generic Causes:
  - Generic causes for the Gb interface failures are defined in 3GPP TS 48.018 [10]. The same cause values are applicable to the PS handover procedure.

### 5.7.2.3 Execution phase failures on the Gn interface

- Update PDP Context failure:
  - As specified in 3GPP TS 29.060 [11] if the new SGSN receives an **Update PDP Context Response** message from the GGSN with a cause value other than 'Request accepted', it shall abort the update of the PDP context. In this case the new SGSN shall inform the old SGSN that the PS handover has been aborted with an appropriate cause value upon which the old SGSN will initiate the deletion of the resources. The new SGSN will initiate the deletion of the resources in the target BSS.

---

## 6 Radio interface Signalling

### 6.1 PS Handover Signalling (Um)

#### 6.1.1 General

PS Handover signalling includes the set of all air interface messages (Um signalling for A/Gb mode and Uu signalling for Iu mode) sent to or from the MS in the source and target cells during the PS handover procedure.

#### 6.1.2 Overview of PS Handover messages

##### 6.1.2.1 GERAN A/Gb mode to GERAN A/Gb mode PS Handover

When performing an inter-SGSN PS Handover from GERAN A/Gb mode to GERAN A/Gb mode the following information is sent over the Um interface.

- **PS Handover Command** message - sent to the MS in the source cell and includes the following:
  - System broadcast information applicable to the target cell. This information may be provided by the target BSS in the Target BSS to Source BSS Transparent Container.

- Indication of the XID parameters (e.g. as specified within an **XID Command** message as defined in 3GPP TS 44.064 [21]) to be used for each unique SAPI associated with all PDP Contexts forwarded to the new SGSN. If layer 3 parameters are included in the XID parameters (e.g. data compression algorithm) and multiple N-SAPIs map to a common SAPI then the layer 3 parameters must indicate the specific N-SAPI associated with a given set of layer 3 parameters.
- Indication of the radio resources for uplink and downlink TBFs to be used in the target cell for each PFC receiving PS handover treatment (i.e. the reverse path container created by target BSS/RNC).
- Indication of a PS handover reference number to be used when the MS arrives in the target cell.
- **PS Handover Access** message - the MS sends 4 handover access bursts in the target cell using an uplink TBF provided by the PS Handover Command. If multiple uplink TBFs are provided by the **PS Handover Command** message the MS sends access bursts using just one of these TBFs (i.e. at minimum one uplink TBF must be provided in the **PS Handover Command** message). The handover reference number is included within each access burst. This message is always sent for the case of unsynchronised cells and may still be sent for the case of synchronised cells (determined by the target BSS during the PS handover preparation phase) to allow the target BSS to verify the accessing MS.
- **Physical Layer Information** message - sent by the target BSS to the MS in the target cell in response to the **PS Handover Access** message for the case of unsynchronised cells. Whether or not this message is sent in case of synchronised cells is indicated by the **PS Handover command** message (see 3GPP TS 44.018 [25]). It is sent using the downlink PACCH associated with the uplink TBF used to send the access bursts and provides the MS with physical layer information (i.e. time alignment information - see 3GPP TS 23.108 [20]). The time alignment information received in this message applies to all uplink TBFs allocated to the MS in the **PS Handover Command** message. The target BSS only sends this information if it receives the expected handover reference number in the access bursts (the same value must be present in each of the 4 access bursts).
- Uplink RLC Data Blocks - sent on uplink TBFs allocated by the **PS Handover Command** message after the MS receives **Physical Layer Information** message as follows:
  - For inter-SGSN PS handover the MS, prior to sending any uplink user plane payload for any PFC, shall send an XID Response for those PFCs that it has received an **XID Command** message.
- Downlink RLC Data Blocks - sent on downlink TBFs allocated by the **PS Handover Command** message as follows:
  - For inter-SGSN PS handover for a given PFC the new SGSN may begin downlink N-PDU transmissions for that PFC prior to receiving a **PS Handover Complete** message, a **Routing Area Update Request** message from the MS or an **XID Response** message for that PFC (i.e. blind transmission may be used) or it may wait for a **PS Handover Complete** message before beginning downlink N-PDU transmissions for that PFC.

### 6.1.2.2 UTRAN/GERAN Iu mode to GERAN A/Gb mode PS Handover

When performing a PS Handover from UTRAN/GERAN Iu mode to GERAN A/Gb mode the following information is sent over the Uu and Um interfaces:

- RRC Message - sent to the MS in the source cell and includes the same information described for the PS Handover Command in clause 6.1.2.1.
- For PS handover from UTRAN the Handover from UTRAN Command (3GPP TS 25.331 [17]) message is used in CELL\_DCH and CELL\_FACH state when only PS RABs are established.
- For PS handover from GERAN Iu mode the HANDOVER FROM GERAN IU COMMAND message is used in RRC-Cell\_Dedicated (MAC Dedicated or MAC DTM state) or RRC-Cell\_Shared state when only PS RABs are established.
- **PS Handover Access** message - sent as described in clause 6.1.2.1.
- **Physical Layer Information** message - sent as described in clause 6.1.2.1.
- Uplink RLC Data Blocks - sent as described in clause 6.1.2.1.
- Downlink RLC Data Blocks - sent as described in clause 6.1.2.1.

### 6.1.2.3 GERAN A/Gb mode to GERAN Iu mode PS Handover

When performing a PS Handover from GERAN A/Gb mode to GERAN Iu mode the following information is sent over the Uu and Um interfaces:

- **PS Handover Command** message - sent to the MS in the source cell and includes the following:
  - System broadcast information applicable to the target cell.
  - Indication of the radio resources for uplink and downlink TBFs to be used in the target cell for each RAB receiving PS handover treatment (i.e. the reverse path container created by target BSS). Note that the MS will map the N-SAPI associated with each of its active PDP Contexts directly to a RABid (i.e. N-SAPI = RABid).
  - Indication of a PS handover reference number to be used when the MS arrives in the target cell.
- **PS Handover Access** message - sent as described in clause 6.1.2.1.
- **Physical Layer Information** message - sent as described in clause 6.1.2.1.
- RRC message (e.g. Physical Channel Reconfiguration Complete) - content is GERAN Iu mode specific.
- Uplink RLC Data Blocks - sent on uplink TBFs allocated by the PS Handover Command after the MS receives Physical Layer Information (content is GERAN Iu mode specific).
- Downlink RLC Data Blocks - sent on downlink TBFs allocated by the PS Handover Command (content is GERAN Iu mode specific).

### 6.1.2.4 GERAN A/Gb mode to UTRAN mode PS Handover

When performing a PS Handover from GERAN A/Gb mode to UTRAN mode the following information is sent over the Uu and Um interfaces:

- **INTER SYSTEM TO UTRAN PS HANDOVER COMMAND** - an RLC/MAC control message sent to the MS in the source cell. It includes the reverse path container created by the target RNC that consists of the RRC message (i.e. the Handover to UTRAN Command) required to perform PS handover to UTRAN.
- MS Detected by Target RNC - exact procedure and information transfer is UTRAN specific.
- RRC message (e.g. Physical Channel Reconfiguration Complete) - information content is UTRAN specific.

## 6.1.3 RLC/MAC segmentation

RLC/MAC segmentation is a feature that provides an additional mechanism for sending control plane messages from the BSS to the MS. This feature can only be used after contention resolution is completed in the BSS and the BSS has to send an RLC/MAC control message that is from 3 to 9 radio blocks long.

### 6.1.4 Inter RAT/mode PS Handover to GERAN A/Gb

Void.

### 6.1.5 Inter RAT/mode PS Handover from GERAN A/Gb

Void.

## 6.2 Mechanisms for Initial Access in the Target Cell

### 6.2.1 General

This clause describes two possible approaches to the MS making access in the target cell. Both basic approaches assume that a handover procedure similar to that for the CS domain (Handover Access followed by Physical Information messages) takes place.

The effect of synchronised networks is examined for both approaches where the exchange of Handover Access and Physical Information is not required as the TA can be derived in advance.

The main assumptions applicable to the call flows are:

- USFs are required to schedule uplink data blocks.
- All identifiers and resources are known by the MS and target BSS before the MS makes the initial access in the target cell.

### 6.2.2 Synchronisation of cells

The same synchronisation mechanisms as used for handover in GSM are used for PS handover. The four cases in GSM are:

- Non-synchronised cells.
- Finely Synchronised cells.
- Pseudo Synchronised cells.
- Pre-Synchronised cells.

The non-synchronised cases are shown in figures 22 and 24 and are characterised by the requirement for the MS to obtain a valid uplink timing advance before it can transmit normal bursts. The MS shall notify its presence in the target cell through the transmission of access bursts to the BSS, and the BSS shall respond with a valid timing advance which in turn enables the MS to send normal bursts in uplink.

The synchronised cases (finely synchronised, pseudo synchronised and pre-synchronised) are shown in figures 23 and 25 and all have different mechanisms for the provision of the timing advance that are described in detail in 3GPP TS 44.018 [25] and 3GPP TS 45.010 [26]. The PS Handover feature will reuse the same solutions.

### 6.2.3 Option 1 - Downlink Data sent after performing access in the target cell

In this approach, downlink data is not transmitted until the BSS has been made aware of the presence of the MS via the reception of a **PS Handover Access** message.

#### 6.2.3.1 Unsynchronised Networks Call Flow

The message flow for this option is shown in figure 22. The MS starts by sending **PS Handover Access** messages as four access bursts to the network. As there is no contention, the network should receive at least one of the access bursts. A Handover Reference parameter is allocated by the target BSS in the **PS Handover Command** message and included in the **PS Handover Access** message to verify that the correct MS is accessing the resources. This is similar to the Handover Reference in the CS handover case.

The BSS receives the **PS Handover Access** message and detects that the correct MS has now made access in the target cell. It sends a message to indicate that the MS has been detected. The main purpose of this message is to give the Timing Advance information to the MS. In this case a message similar to the **Physical Information** message defined for CS handover can be used. It is called the **Packet Physical Information** message.

Once the MS has received the **Packet Physical Information** message it sends an **XID Response** message to the new SGSN for each PFC subject to PS handover. When correctly receiving the first RLC data block from the MS the target BSS verifies the mobile station generates a **PS Handover Complete** message and sends it to the new SGSN.

As soon as the **XID Response** message is sent the MS can start sending uplink RLC/MAC data blocks on the pre-allocated resources when scheduled with its USF. When the **XID Response** message has arrived in the new SGSN the SGSN can start sending downlink data blocks.

Note: It is in case assumed that downlink RLC data blocks are sent for a PFC receiving PS handover treatment after the target BSS has confirmed that the correct MS is present and after the **PS Handover Complete** message has been received by the new SGSN for that PFC.

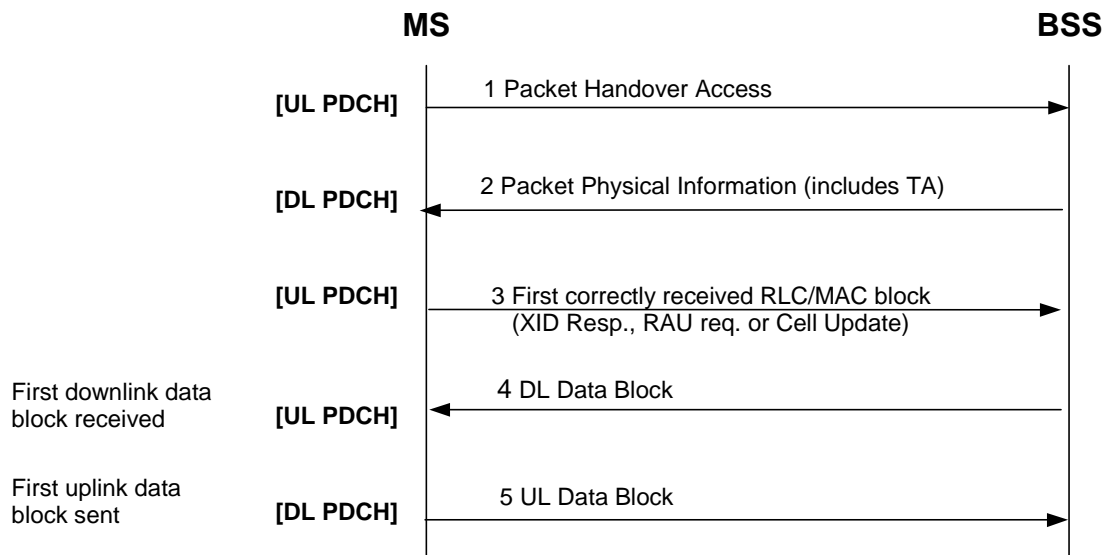

Figure 22: Option 1 - Downlink Data after MS contacts network

### 6.2.3.2 Synchronised Networks Call Flow

In the case of synchronous networks it is possible for the MS to calculate the TA of the target cell before it moves from the source cell.

Figure 23 shows the call flow in the case of synchronous networks. In this case it is possible for the MS to start transmitting and receiving messages as soon as it switches to the target cell.

As described in 3GPP TS 44.018 [25], handover access bursts may optionally be sent if indicated in the handover command message. If no access bursts are sent the first message sent in the uplink may be one of the **XID Response**, **RAU Request** or **Cell Update** messages. This message is only sent to verify the MS's presence in the new cell but does not trigger the sending of any **Physical Information** message. As blind transmission in the downlink is not being used in this scenario, the BSS must wait until a message is received before transmitting data in the downlink. This means that the MS cannot send the first uplink data block until it receives the USF in the first downlink data block.

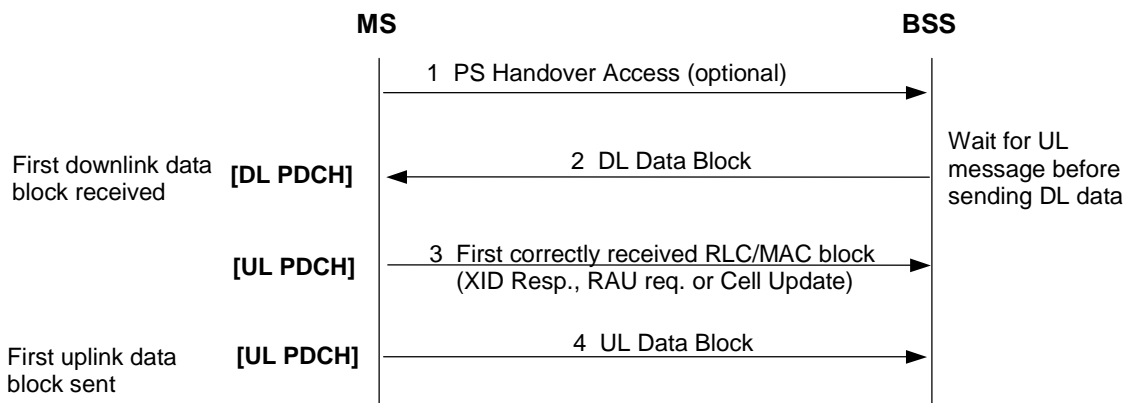

Figure 23: Option 1 - Downlink Data after MS contacts network, Synchronous Networks

### 6.2.4 Option 2 - Downlink Data sent before performing access in the target cell (Blind Transmission)

Blind transmission aims at minimising the interruption time on the downlink following handover. The target BSS starts transmitting downlink data on the newly reserved resources in the target cell before the MS has synchronised with this cell (i.e. prior to receiving timing advance in the **Packet Physical Information** message). The message flow for this scheme is shown in figure 24.

#### 6.2.4.1 Unsynchronised Networks Call Flow

As the BSS must send the Packet Physical Information as an immediate response to the **Packet Handover Access** message, it is unable to send any downlink data at the same time. Therefore the BSS interrupts delivery of downlink data in order to send the Packet Physical Information to the MS.

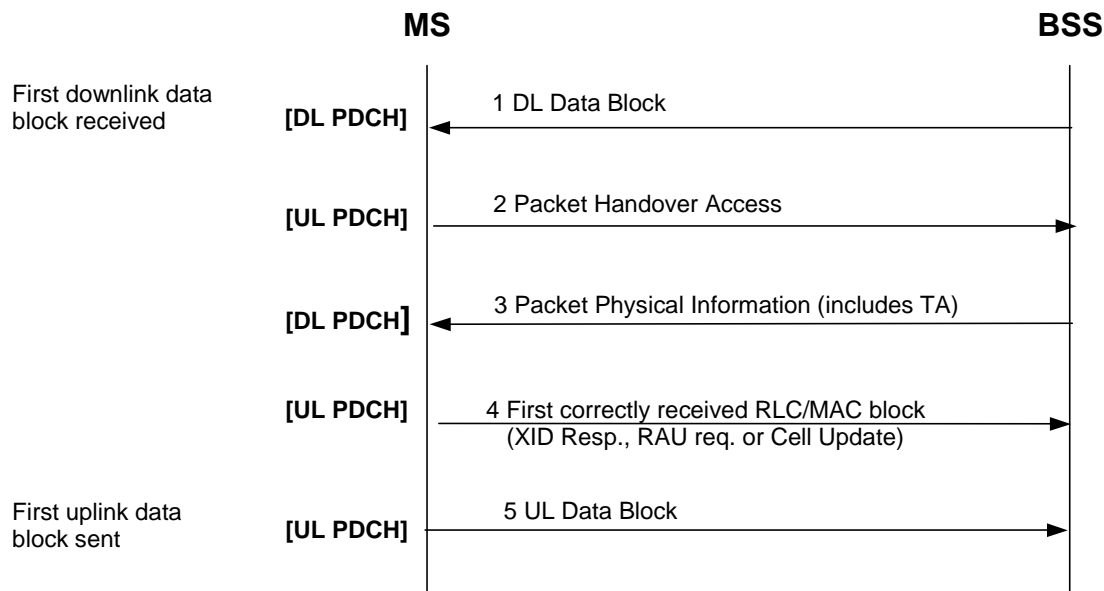

NOTE 1: DL data is shown as being sent before the Packet Handover Access, but it may be sent by the target BSS at any time in the sequence. The **PS Handover Access** message is sent when being scheduled with the USF.

NOTE 2: Blind transmission assumes that the downlink data flow for a PFC receiving PS handover treatment may begin before the new SGSN receives the associated **PS Handover Complete** message from the target BSS and before the RAU procedure has started.

Figure 24: Option 2 - Blind Transmission in target cell

### 6.2.4.2 Synchronised Network Call Flow

In the case of blind transmission with synchronous networks, downlink data can be sent at the earliest opportunity. This is similar to the case for blind transmission without synchronous networks. However, uplink data transfer is also sped-up as shown in the call flow of figure 25.

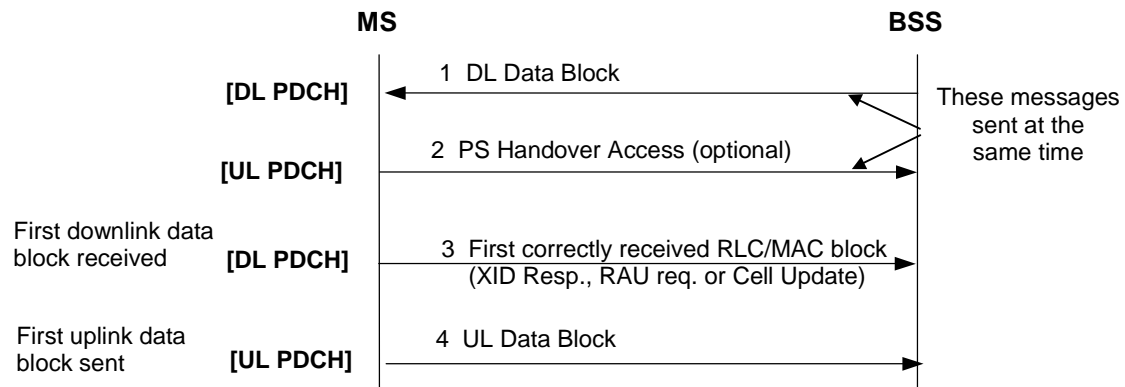

**Figure 25: Option 2 - Blind Transmission in target cell, Synchronous Networks**

The first uplink data sent will consist of either the **PS Handover Access** message (optional) or one or more RLC data blocks that may contain the **XID Response** message, **RAU Request** message or the **Cell Update** message. This case is therefore the best in terms of reduced service interruption time.

As described in 3GPP TS 44.018 [25], handover access bursts may optionally be sent if indicated in the handover command message.

**NOTE:** Blind transmission assumes that the flow of downlink data for a PFC receiving PS handover treatment may begin before the new SGSN receives the associated **PS Handover Complete** message from the target BSS and before the RAU procedure has started.

## 6.3 Methods for triggering PS Handover

A PS Handover is triggered by the BSS based on the received measurement reports or initiated by the reception of the **Packet Cell Change Notification** message from the mobile station. The BSS controls which of the two methods to use for initiating the PS Handover.

When PS Handover is triggered by the BSS based on the measurement reports, the mobile station is in NC2 mode. The mobile station sends measurement reports to the network (BSS). When the network has found a new cell meeting the cell reselection criteria, and prepared for the PS Handover in that target cell, it sends the **PS Handover Command** message to the mobile station.

If not in NC2 mode, the mobile station may, by transmitting a **Packet Cell Change Notification** message according to the Cell Change Notification procedure, make the BSS aware it has found a new cell meeting the cell reselection criteria. The network then prepares for the PS Handover in the indicated target cell and sends the **PS Handover Command** message to the mobile station. In order to avoid that the mobile station performs autonomous cell reselection due to timeout of T3208, the network can order the mobile station to enter NC2 mode by transmitting the **Packet Measurement Order** message in response to the PCCN message. This will keep the mobile station in the cell until the **PS Handover Command** message is sent by the network, thus making it possible for the network to perform all necessary PS handover signalling and set up the radio resources in the target cell.



---

# Annex A (normative): Agreed handover principles

## A.1 Agreed handover principles

1. It is the mobile station that is handed over to a target cell when one or more of its PFCs are subject to handover.
2. The source BSS makes the decision to initiate the handover preparation phase when required for PFC(s) subject to handover.
3. Information pertaining to all PDP contexts and PFCs relating to the MS should be sent from the old SGSN to the target SGSN in the handover signalling regardless of their QoS.
4. The target BSS should make the final decision on which PFCs are subject to handover and to assign resources over the Um interface in the target cell. This decision is based on the target BSS being able to fulfil the QoS for these PFCs.
5. The old SGSN decides whether and when to forward data to the TEIDs provided by the new SGSN.
6. It is not required to have resources allocated in advance for bearers which themselves are not determined to be subject to handover by the target BSS.
7. How the target BSS decides which PFCs to accept and which to reject should be implementation specific.
8. For the PS Handover, forwarding of data is performed from the old SGSN either to the target BSS (intra BSS, intra SGSN-inter BSS) or to the new SGSN (inter SGSN); an optional optimisation for intra BSS handover will allow the BSS to decide how to handle the user data flow.
9. An explicit Routing Area Update procedure is performed (if required) when the handover procedure is terminated.
10. The explicit RAU may not contain the following message sequences that are performed already during the handover procedure:
  - Transfer of contexts between SGSNs (inter SGSN case).
  - Exchange of SMDCP sequence numbers (inter SGSN case).
  - Allocation of P-TMSI.
11. Uplink and downlink data transfer continues during the Routing Area Update procedure. This is possible because certain RAU centric functions are performed during the handover execution phase.
12. The PS Handover service shall support intra BSS, intra SGSN-inter BSS, inter SGSN and inter RAT scenarios.
13. Based on the quality of service parameters the MS or the network may throw away packets available for transmission in the uplink or downlink during the ongoing handover procedure.
14. The source BSS shall only request PS handover for one cell in each **PS Handover Required** message.
15. The PS handover procedure is only performed when the target BSS pre-allocates resource for at least one PFC. In case the target BSS cannot allocate resources for at least one PFC the target BSS shall reject the PS Handover request using the **PS Handover Reject** message.
16. In case the mobile fails to synchronize to the target cell within a timeout period after having received a PS Handover Command, shall revert to the source cell and the old "channels".
17. Optionally, in the case of Intra RAT/Mode PS handover, information pertaining to the radio resource realization of the PFCs subject to Handover can be transferred from the source BSS to the target BSS.

18. During the PS Handover preparation phase the new SGSN (assuming RA change) assigns a unique identifier (P-TMSI, Local TLLI) for data transmission in the target cell. This Local TLLI is used for data transfer between the target BSS and the new SGSN. This Local TLLI is not sent to the MS. After PS Handover Completion the MS triggers the RAU procedure. After P-TMSI reallocation, which is performed during Routing area update, a new Local TLLI will be derived from the P-TMSI using current MM procedures.

---

## Annex B (informative): Change history

Change history							
Date	TSG #	TSG Doc.	CR	Rev	Subject/Comment	Old	New
2004-11	22	GP-042904	-	-	Version for Release 6	-	6.0.0
2005-01	23	GP-050450	001	1	Correction of data forwarding in case of inter-RAT PS Handover	6.0.0	6.1.0
2005-01	23	GP-050323	002		"Layer 3 information" not used for PS Handover	6.0.0	6.1.0
2005-01	23	GP-050603	004	2	Clarification of PDP Context Suspension During Inter-SGSN GERAN A/Gb to GERAN A/Gb PS Handover	6.0.0	6.1.0
2005-01	23	GP-050326	005		PS Handover Cancel after failed PS Handover	6.0.0	6.1.0
2005-01	23	GP-050327	006		Addition of the SABM-UA exchange procedure	6.0.0	6.1.0

---

# History

<b>Document history</b>		
V6.1.0	January 2005	Publication