



**SPECIFICATION
FOR
LCD Module
KD020C-1 V2**

MODULE:	KD020C-1 V2
CUSTOMER:	

REV	DESCRIPTION	DATE
1.0	FIRST ISSUE	2013.05.10

STARTEK	INITIAL	DATE
PREPARED BY		
CHECKED BY		
APPROVED BY		

CUSTOMER	INITIAL	DATE
APPROVED BY		

Part. No	KD020C-1 V2	REV	V1.0	Page 1 of 25
----------	-------------	-----	------	--------------

常备库存
Standing Stock

长期供货
Long Availability

支持小量
NO MOQ

品种齐全
In Full Range



Contents

General Description	-----4
1.Block Diagram	-----5
2. Outline dimension	-----6
3. Input Terminal Pin Assignment	-----7
4. LCD Optical Characteristics	-----9
5. Electrical Characteristics	-----11
6. AC Characteristic	-----13
7. LCD Module Out-Going Quality Level	-----14
8 Reliability Test Result	-----27
9.Cautions and Handling Precautions	-----28
10.Packing	-----29

Part. No	KD020C-1 V2	REV	V1.0	Page 3 of 25
	常备库存 Standing Stock	长期供货 Long Availability	支持少量 NO MOQ	品种齐全 In Full Range



General Description

* Description

This is a color active matrix TFT (Thin Film Transistor) LCD (liquid crystal display) that uses amorphous silicon TFT

as a switching device. This model is composed of a Transmissive type TFT-LCD Panel, driver circuit, back-light unit. The resolution of a 2.0" TFT-LCD contains 176x220 pixels, and can display up to 65K colors.

* Features

-Low Input Voltage: 3.3V(TYP)

-Display Colors of TFT LCD: 65Kcolors

- Interface: 8Bit MCU

General Information Items	Specification	Unit	Note
	Main Panel		
Display area(AA)	31.68(H)*39.6(V) (2.0inch)	mm	-
Driver element	TFT active matrix	-	-
Display colors	65K	colors	-
Number of pixels	176(RGB)*220	dots	-
Pixel arrangement	RGB vertical stripe	-	-
Pixel pitch	0.180(H)*0.180 (V)	mm	-
Viewing angle	12:00	o'clock	-
Controller IC	ST7775R	-	-
Display mode	Transmissive/ Normally White	-	-
Operating temperature	-20~+70	°C	-
Storage temperature	-30~+80	°C	-

* Mechanical Information

Item		Min.	Typ.	Max.	Unit	Note
Module size	Horizontal(H)		38.4		mm	-
	Vertical(V)		51.4		mm	-
	Depth(D)		2.35		mm	-
Weight			TBD		g	-



1. Block Diagram

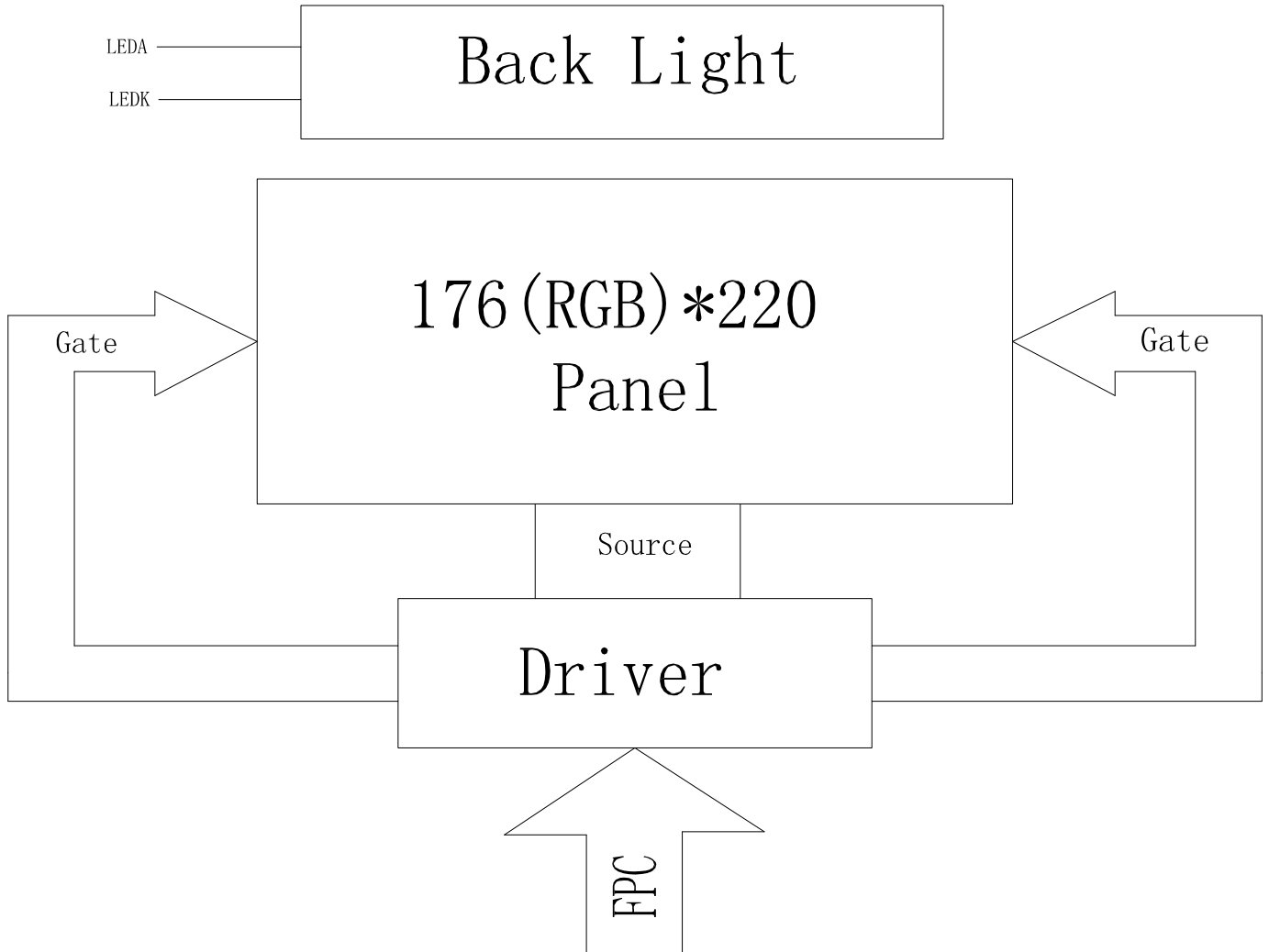

Part. No	KD020C-1 V2	REV	V1.0	Page 5 of 25
	常备库存 Standing Stock	长期供货 Long Availability	支持少量 NO MOQ	品种齐全 In Full Range



2. Outline dimension

Part. No	KD020C-1 V2	REV	V1.0	Page 6 of 25
	常备库存 Standing Stock	长期供货 Long Availability	支持少量 NO MOQ	品种齐全 In Full Range



Pin	Name
1	GND
2	NC
3	RESET
4	NC
5	NC
6	NC
7	NC
8	NC
9	NC
10	NC
11	NC
12	DB0
13	DB1
14	DB2
15	DB3
16	DB4
17	DB5
18	DB6
19	DB7
20	RD
21	WR
22	RS
23	CS
24	VCC
25	GND
26	VCCIO
27	NC
28	XR
29	YD
30	XL
31	YU
32	GND
33	LED1+
34	LED2+
35	LED3+
36	NC
37	LED-

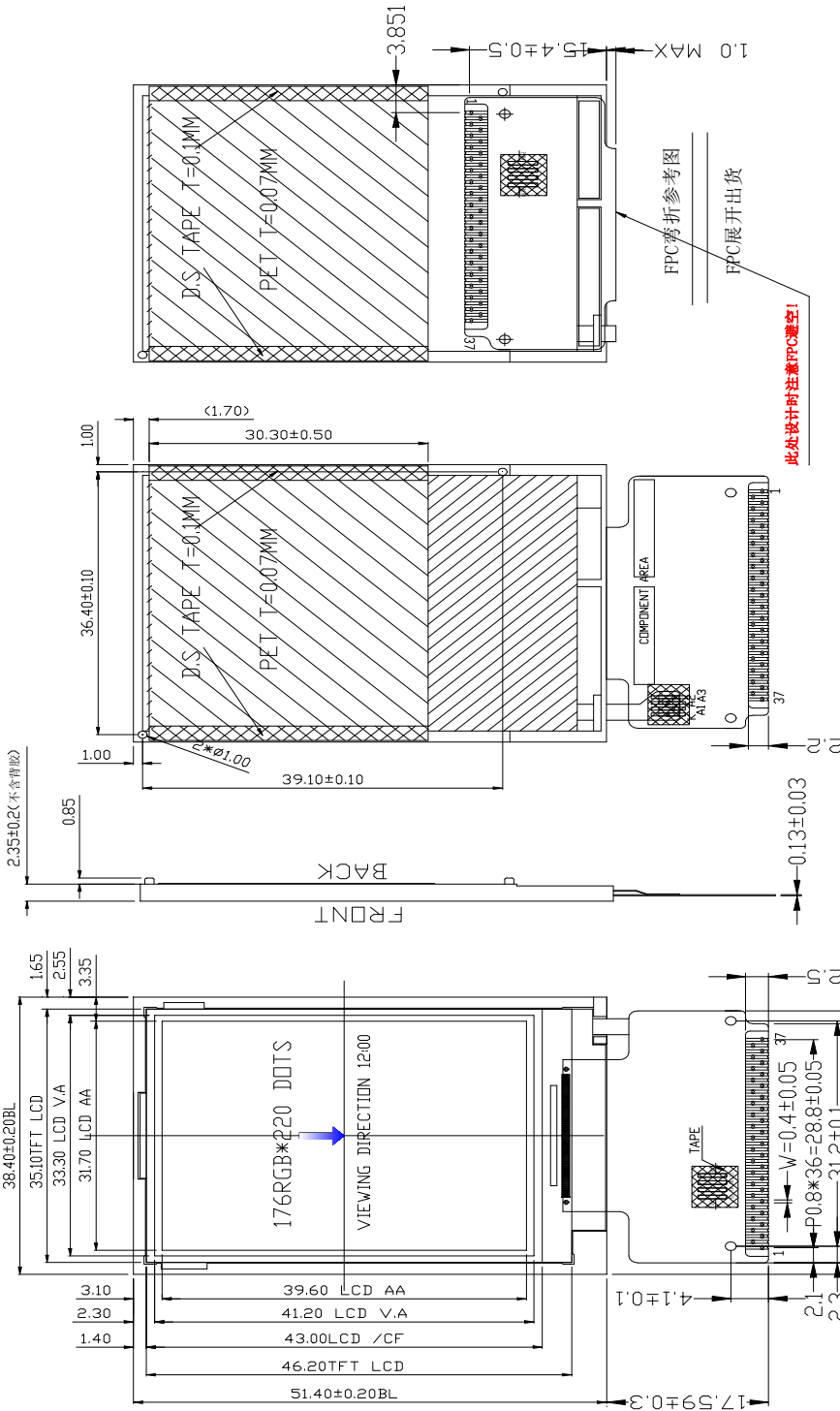

B/L CIRCUIT DIAGRAM

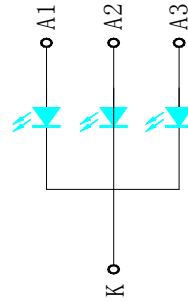

NOTES:

1. DISPLAY TYPE: 2.0", TFT-LCD, 65K COLORS
2. DISPLAY MODE: T/M NORMALLY WHITE
3. VIEWING DIRECTION: 12:00
4. DRIVER IC: ST7775R (COG)
5. VCI: 3.3V(TYP)
6. OPERATING TEMP: -20° C TO 70° C
STORAGE TEMP: -30° C TO 80° C
7. BACK LIGHT: LED WHITE, 3 LED, 45mA, 3.2±0.3V
8. RoHS COMPLIANT.

深圳市柯达科电子科技有限公司
Shenzhen Startek Electronic Technology Co.,Ltd

Revision content description		Date
A	FIRST	2012/12/17

TOLERANCE(公差)	±0.2	DRAWING NAME	KD020C-1-V2-LCM
TOLERANCE UNLESS OTHERWISE SPECIFIED	X.X±0.3	Drawn	Unit
	X.XX±0.2	Checked	mm
Scale	1:1	Approve	Page 1/1

Part. No	KD020C-1 V2	REV	V1.0	Page 7 of 25
常备库存 Standing Stock	长期供货 Long Availability	支持小量 NO MOQ	品种齐全 In Full Range	



3. Input terminal Pin Assignment

NO.	SYMBOL	DISCRIPTION	I/O
1	GND	Ground.	P
2	NC		
3	RESET	This signal will reset the device and must be applied to properly initialize the chip.	I
4-11	NC		
12-19	DB0-DB7	Data bus.	I/O
20	RD	Read enable. if not used, please connect this pin to VDD	I
21	WR	Write enable in parallel interface.	I
22	RS	Display data / Command selection pin.	I
23	CS	Chip select input pin ("Low" enable). This pin can be permanently fixed "Low" in MCU interface mode only.	I
24	VCC	Supply voltage (3.3V).	P
25	GND	Ground.	P
26	VCCIO	Supply voltage for IO(1.8V-3.3V).	P
27	NC		
28	XR(NC)		
29	YD(NC)		
30	XL(NC)		
31	YU(NC)		
32	GND	Ground.	P
33	LEDA1	Anode pin of backlight.	P
34	LEDA2	Anode pin of backlight.	P
35	LEDA3	Anode pin of backlight.	P
36	NC		
37	LEDK	Cathode pin OF backlight.	P



4. LCD Optical Characteristics

4.1 Optical specification

Item	Symbol	Condition	Min.	Typ.	Max.	Unit	Note	
Transmittance (without Polarizer)	T(%)	—	—	16.0	—	—		
Contrast Ratio	CR	$\Theta=0$	400	500	—	—	(1)(2)	
Response time	Rising	T_R	Normal viewing angle	—	2	4	msec	(1)(3)
	Falling	T_F		—	6	12		
Color gamut	S(%)			60		%		
Color chromaticity (CIE1931)	White	W_x		0.283	0.303	0.323	(1)(4) CF glass	
		W_y		0.305	0.325	0.345		
	Red	R_x		0.606	0.626	0.646		
		R_y		0.314	0.334	0.354		
	Green	G_x		0.257	0.277	0.397		
		G_y		0.529	0.549	0.569		
	Blue	B_x		0.122	0.142	0.162		
		B_y		0.102	0.122	0.142		
Viewing angle	Hor.	Θ_L	CR>10	35	45	—		
		Θ_R		35	45	—		
	Ver.	Θ_U		35	45	—		
		Θ_D		10	20	—		
Optima View Direction	12 O'clock						(5)	

4.2 Measuring Condition

■ Measuring surrounding : dark room

■ Ambient temperature : $25 \pm 2 \text{ }^\circ\text{C}$

Part. No	KD020C-1 V2	REV	V1.0	Page 9 of 25
----------	-------------	-----	------	--------------

常备库存
Standing Stock

长期供货
Long Availability

支持少量
NO MOQ

品种齐全
In Full Range



■ 15min. warm-up time.

4.3 Measuring Equipment

- FPM520 of Westar Display technologies, INC., which utilized SR-3 for Chromaticity and BM-5A for other optical characteristics.

Note (1) Definition of Viewing Angle :

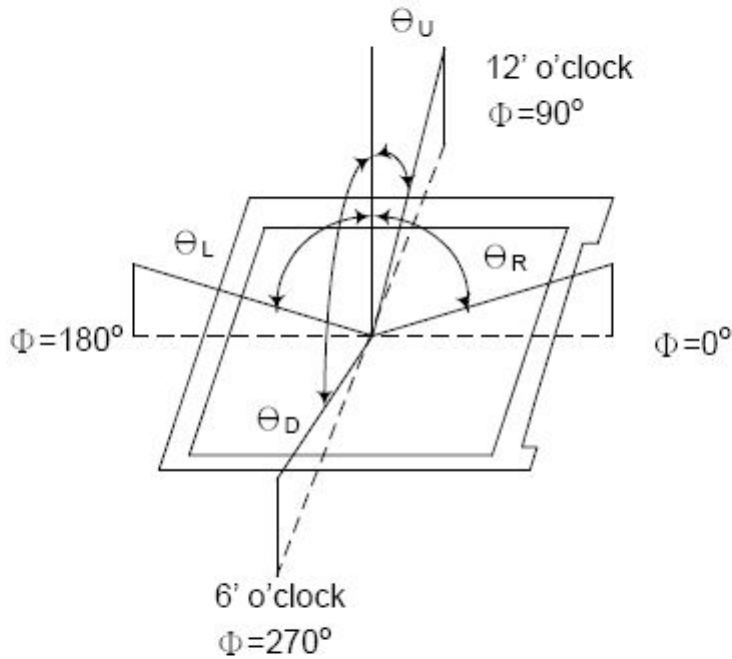

Note (2) Definition of Contrast Ratio(CR) :
measured at the center point of panel

$$CR = \frac{\text{Luminance with all pixels white}}{\text{Luminance with all pixels black}}$$



5. Electrical Characteristics

5.1 Absolute Maximum Rating (Ta=25 VSS=0V)

Characteristics	Symbol	Min.	Max.	Unit
Digital Supply Voltage	VDD	-0.3	4.6	V
Digital interface supply Voltage	VDDIO	-0.3	4.6	V
Operating temperature	T _{OP}	-20	+70	°C
Storage temperature	T _{ST}	-30	+80	°C

5.2 DC Electrical Characteristics

Characteristics	Symbol	Min.	Typ.	Max.	Unit	Note
Digital Supply Voltage	VDD	2.5	3..3	4.2	V	
Digital interface supply Voltage	VDDIO	1.65	3.3	4.2	V	
Normal mode Current consumption	IDD	--	2.5	--	mA	
Level input voltage	V _{IH}	0.8V _{DDIO}		V _{DDIO}	V	
	V _{IL}	GND		0.3V _{DDIO}	V	
Level output voltage	V _{OH}	0.8V _{DDIO}		V _{DDIO}	V	
	V _{OL}	GND		0.2V _{DDIO}	V	

5.3 LED Backlight Characteristics

The back-light system is edge-lighting type with 3 chips White LED

Item	Symbol	Min.	Typ.	Max.	Unit	Note
Forward Current	I _F	45	60	--	mA	
Forward Voltage	V _F	--	3.2	--	V	
LCM Luminance	L _V	350	--	--	cd/m ²	
Uniformity	AV _g	80	--	--	%	

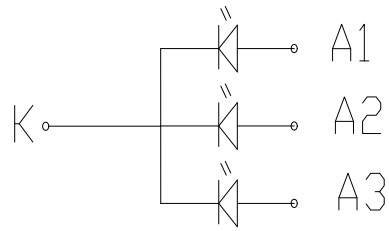

LED CIRCUIT DIAGRAM

Part. No	KD020C-1 V2	REV	V1.0	Page 12 of 25
----------	-------------	-----	------	---------------

常备库存
Standing Stock

长期供货
Long Availability

支持小量
NO MOQ

品种齐全
In Full Range



6. AC Characteristic

6.1. Display Parallel 18/16/9/8-bit Interface Timing Characteristics (8080- system)

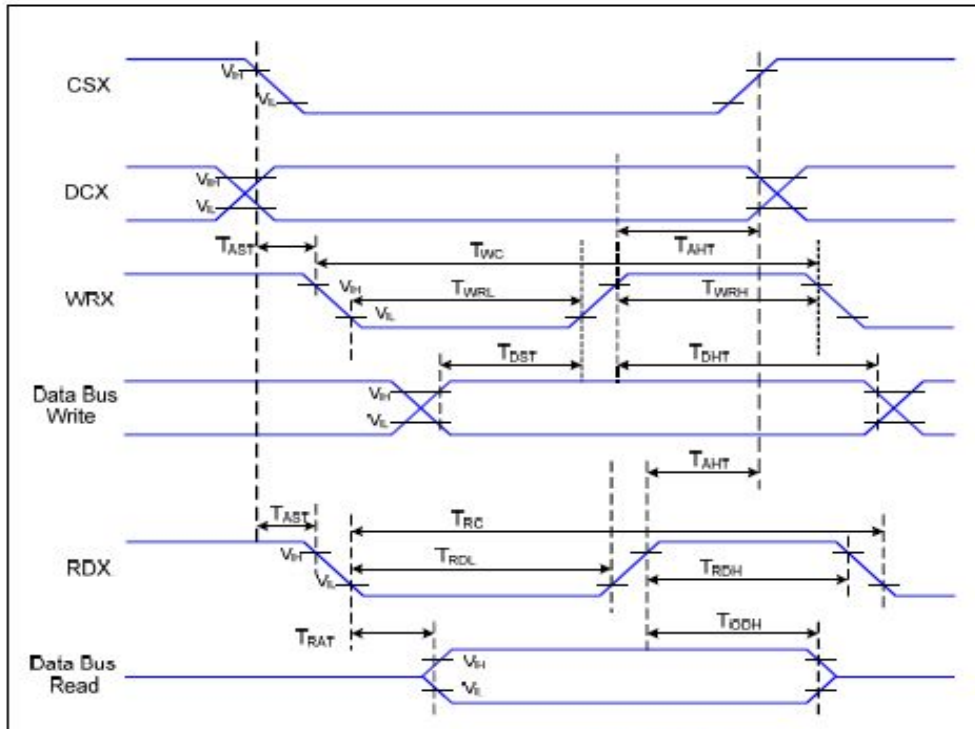

Figure 1 Parallel Interface Timing Characteristics (8080-Series MCU Interface)

VDDI=1.65 to 3.3V, VDD=2.5 to 3.3V, AGND=DGND=0V, Ta=25 °C

Signal	Symbol	Parameter	Min	Max	Unit	Description
DCX	TAST	Address Setup Time	10	-	ns	
	TAHT	Address Hold Time (Write/Read)	5	-	ns	
WRX	TWC	Write Cycle	70	-	ns	
	TWRH	Control Pulse "H" Duration	35	-	ns	
	TWRL	Control Pulse "L" Duration	35	-	ns	
RDX	TRC	Read Cycle (ID)	300	-	ns	When Read ID Data
	TRDH	Control Pulse "H" Duration (ID)	150	-	ns	
	TRDL	Control Pulse "L" Duration (ID)	150	-	ns	
DB[17:0]	TDST	Data Setup Time	10	-	ns	TRAT, TRATFM: 3K ohm Pull up or Down and 30pF Parallel Cap. To GND. TODH: 3K ohm Pull up or Down.
	TDHT	Data Hold Time	15	-	ns	
	TRAT	Read Access Time (ID)	-	100	ns	
	TODH	Output Disable Time	50	-	ns	

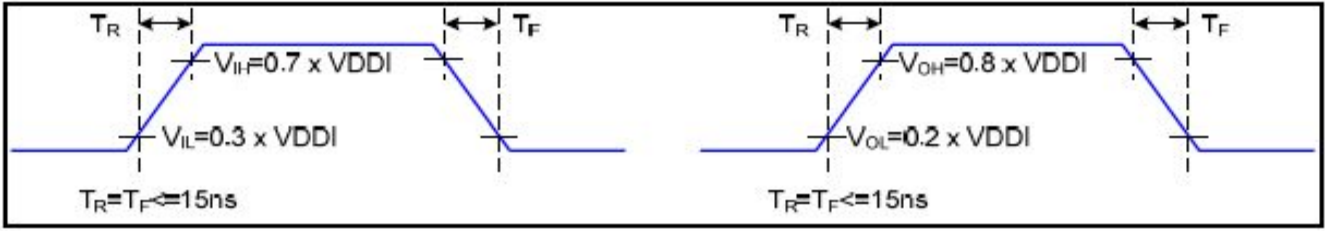

Figure 2 Rising and Falling Timing for I/O Signal

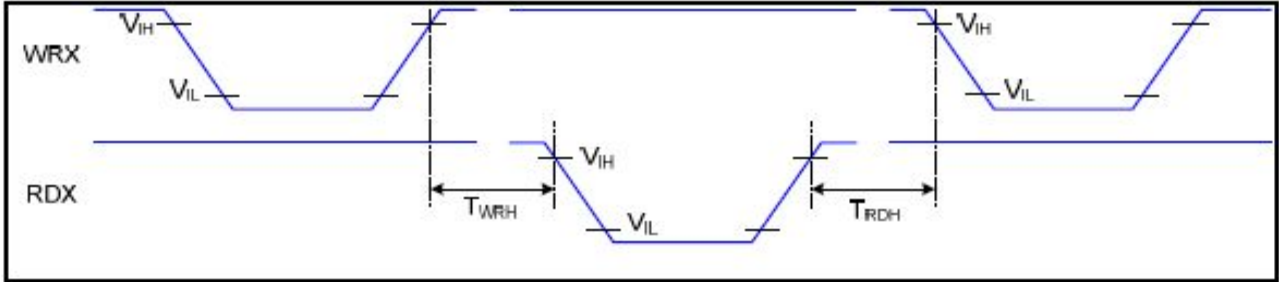

Figure 3 Write-to-Read and Read-to-Write Timing

Note: The rising time and falling time (T_r , T_f) of input signal and fall time are specified at 15 ns or less. Logic high and low levels are specified as 30% and 70% of VDDI for Input signals.

Part. No	KD020C-1 V2	REV	V1.0	Page 14 of 25
	常备库存 Standing Stock	长期供货 Long Availability	支持小量 NO MOQ	品种齐全 In Full Range



7. LCD Module Out-Going Quality Level

7.1 VISUAL & FUNCTION INSPECTION STANDARD

7.1.1 Inspection conditions

Inspection performed under the following conditions is recommended.

Temperature : $25 \pm 5^{\circ}\text{C}$

Humidity : $65\% \pm 10\% \text{RH}$

Viewing Angle : Normal viewing Angle.

Illumination: Single fluorescent lamp (300 to 700Lux)

Viewing distance:30-50cm

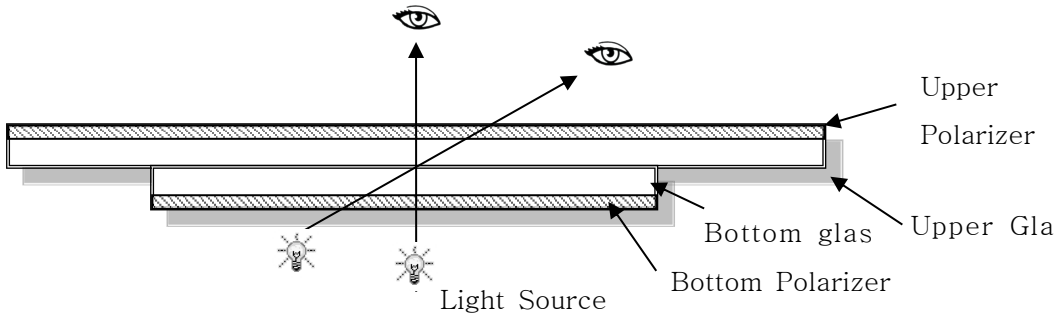

7.1.2 Definition

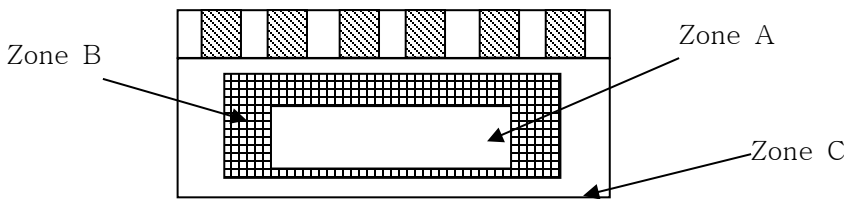

Zone A : Effective Viewing Area(Character or Digit can be seen)

Zone B : Viewing Area except Zone A

Zone C : Outside (Zone A+Zone B) which can not be seen after assembly by customer .)

Note:

As a general rule ,visual defects in Zone C can be ignored when it doesn't effect product function or appearance after assembly by customer.

Part. No	KD020C-1 V2	REV	V1.0	Page 15 of 25
	常备库存 Standing Stock	长期供货 Long Availability	支持少量 NO MOQ	品种齐全 In Full Range



7.1.3 Sampling Plan

According to GB/T 2828-2003 ; , normal inspection, Class II

AQL:

Major defect	Minor defect
0.65	1.5

LCD: Liquid Crystal Display , TP: Touch Panel , LCM: Liquid Crystal Module

N o	Items to be inspected	Criteria	Classification of defects
1	Functional defects	1) No display, Open or miss line 2) Display abnormally, Short 3) Backlight no lighting, abnormal lighting. 4) TP no function	Major
2	Missing	Missing component	
3	Outline dimension	Overall outline dimension beyond the drawing is not allowed	
4	Color tone	Color unevenness, refer to limited sample	Minor
5	Soldering appearance	Good soldering , Peeling off is not allowed.	
6	LCD/Polarizer/TP	Black/White spot/line, scratch, crack, etc.	

7

7.1.4 Criteria (Visual)

Number	Items	Criteria(mm)
--------	-------	--------------

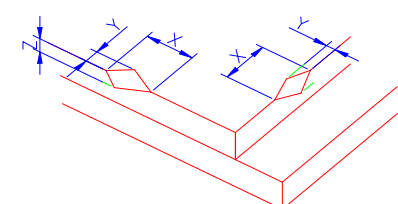
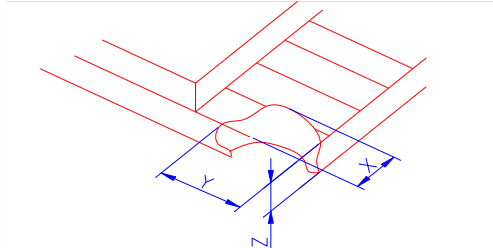
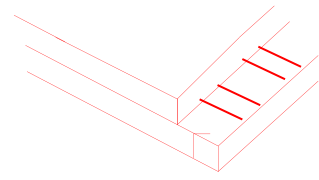

<p>1.0 LCD Crack/Broken</p>	<p>(1) The edge of LCD broken</p>	 <table border="1" data-bbox="861 492 1388 649"> <tr> <td>X</td> <td>Y</td> <td>Z</td> </tr> <tr> <td>≤3.0mm</td> <td><Inner border line of the seal</td> <td>≤T</td> </tr> </table>	X	Y	Z	≤3.0mm	<Inner border line of the seal	≤T
X	Y	Z						
≤3.0mm	<Inner border line of the seal	≤T						
<p>NOTE: X: Length Y: Width Z: Height L: Length of ITO, T: Height of LCD</p>	<p>(2) LCD corner broken</p>	 <table border="1" data-bbox="917 985 1332 1086"> <tr> <td>X</td> <td>Y</td> <td>Z</td> </tr> <tr> <td>≤3.0mm</td> <td>≤L</td> <td>≤T</td> </tr> </table>	X	Y	Z	≤3.0mm	≤L	≤T
X	Y	Z						
≤3.0mm	≤L	≤T						
	<p>(3) LCD crack</p>	 <p>Crack Not allowed</p>						



Number	Items	Criteria (mm)
--------	-------	---------------

Part. No	KD020C-1 V2	REV	V1.0	Page 18 of 25
	常备库存 Standing Stock	长期供货 Long Availability	支持少量 NO MOQ	品种齐全 In Full Range



2.0

Spot defect

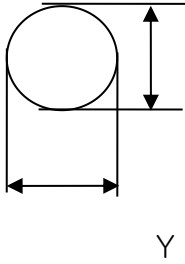

① light dot (LCD/TP/Polarizer black/white spot, light dot, pinhole, dent, stain)

Zone Size (mm)	Acceptable Qty		
	A	B	C
$\Phi \leq 0.10$	Ignore		
$0.10 < \Phi \leq 0.15$	3(distance $\geq 10\text{mm}$)		
$0.15 < \Phi \leq 0.2$	1		
$0.2 < \Phi$	0		

X

$\Phi = (X+Y)/2$

② Dim spot (LCD/TP/Polarizer dim dot, light leakage, dark spot)

Zone Size (mm)	Acceptable Qty		
	A	B	C
$\Phi \leq 0.1$	Ignore		
$0.1 < \Phi \leq 0.2$	2(distance $\geq 10\text{mm}$)		
$0.2 < \Phi \leq 0.3$	1		
$\Phi > 0.3$	0		

③ Polarizer accidented spot

Zone Size (mm)	Acceptable Qty		
	A	B	C
$\Phi \leq 0.2$	Ignore		
$0.2 < \Phi \leq 0.5$	2(distance $\geq 10\text{mm}$)		
$\Phi > 0.5$	0		

Line defect (LCD/TP /Polarizer black/white line, scratch, stain)

Width(mm)	Length(mm)	Acceptable Qty		
		A	B	C
$\Phi \leq 0.03$	Ignore	Ignore		Ignore
$0.03 < W \leq 0.05$	$L \leq 3.0$	$N \leq 2$		
$0.05 < W \leq 0.08$	$L \leq 2.0$	$N \leq 2$		
$0.08 < W$	Define as spot defect			

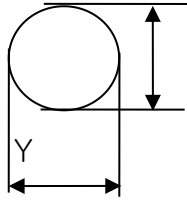

Items	Criteria (mm)																																																																	
Spot defect  $\Phi = (X+Y)/2$	<p>① light dot (LCD/TP/Polarizer black/white spot , light dot, pinhole, dent, stain)</p> <table border="1" data-bbox="414 739 1340 1086"> <thead> <tr> <th rowspan="2">Zone Size (mm)</th> <th colspan="3">Acceptable Qty</th> </tr> <tr> <th>A</th> <th>B</th> <th>C</th> </tr> </thead> <tbody> <tr> <td>$\Phi \leq 0.10$</td> <td colspan="3">Ignore</td> </tr> <tr> <td>$0.10 < \Phi \leq 0.15$</td> <td colspan="3">3(distance $\geq 10\text{mm}$)</td> </tr> <tr> <td>$0.15 < \Phi \leq 0.2$</td> <td colspan="3">1</td> </tr> <tr> <td>$0.2 < \Phi$</td> <td colspan="3">0</td> </tr> </tbody> </table> <p>② Dim spot (LCD/TP/Polarizer dim dot, light leakage, dark spot)</p> <table border="1" data-bbox="414 1187 1364 1534"> <thead> <tr> <th rowspan="2">Zone Size (mm)</th> <th colspan="3">Acceptable Qty</th> </tr> <tr> <th>A</th> <th>B</th> <th>C</th> </tr> </thead> <tbody> <tr> <td>$\Phi \leq 0.1$</td> <td colspan="3">Ignore</td> </tr> <tr> <td>$0.1 < \Phi \leq 0.2$</td> <td colspan="3">2(distance $\geq 10\text{mm}$)</td> </tr> <tr> <td>$0.2 < \Phi \leq 0.3$</td> <td colspan="3">1</td> </tr> <tr> <td>$\Phi > 0.3$</td> <td colspan="3">0</td> </tr> </tbody> </table> <p>③ Polarizer accidented spot</p> <table border="1" data-bbox="414 1635 1228 1926"> <thead> <tr> <th rowspan="2">Zone Size (mm)</th> <th colspan="3">Acceptable Qty</th> </tr> <tr> <th>A</th> <th>B</th> <th>C</th> </tr> </thead> <tbody> <tr> <td>$\Phi \leq 0.2$</td> <td colspan="3">Ignore</td> </tr> <tr> <td>$0.2 < \Phi \leq 0.5$</td> <td colspan="3">2(distance $\geq 10\text{mm}$)</td> </tr> <tr> <td>$\Phi > 0.5$</td> <td colspan="3">0</td> </tr> </tbody> </table>	Zone Size (mm)	Acceptable Qty			A	B	C	$\Phi \leq 0.10$	Ignore			$0.10 < \Phi \leq 0.15$	3(distance $\geq 10\text{mm}$)			$0.15 < \Phi \leq 0.2$	1			$0.2 < \Phi$	0			Zone Size (mm)	Acceptable Qty			A	B	C	$\Phi \leq 0.1$	Ignore			$0.1 < \Phi \leq 0.2$	2(distance $\geq 10\text{mm}$)			$0.2 < \Phi \leq 0.3$	1			$\Phi > 0.3$	0			Zone Size (mm)	Acceptable Qty			A	B	C	$\Phi \leq 0.2$	Ignore			$0.2 < \Phi \leq 0.5$	2(distance $\geq 10\text{mm}$)			$\Phi > 0.5$	0		
Zone Size (mm)	Acceptable Qty																																																																	
	A	B	C																																																															
$\Phi \leq 0.10$	Ignore																																																																	
$0.10 < \Phi \leq 0.15$	3(distance $\geq 10\text{mm}$)																																																																	
$0.15 < \Phi \leq 0.2$	1																																																																	
$0.2 < \Phi$	0																																																																	
Zone Size (mm)	Acceptable Qty																																																																	
	A	B	C																																																															
$\Phi \leq 0.1$	Ignore																																																																	
$0.1 < \Phi \leq 0.2$	2(distance $\geq 10\text{mm}$)																																																																	
$0.2 < \Phi \leq 0.3$	1																																																																	
$\Phi > 0.3$	0																																																																	
Zone Size (mm)	Acceptable Qty																																																																	
	A	B	C																																																															
$\Phi \leq 0.2$	Ignore																																																																	
$0.2 < \Phi \leq 0.5$	2(distance $\geq 10\text{mm}$)																																																																	
$\Phi > 0.5$	0																																																																	





Line defect (LCD/TP /Polarizer black/white line, scratch, stain)	Width(mm)	Length(mm)	Acceptable Qty		
			A	B	C
	$\Phi \leq 0.03$	Ignore	Ignore		Ignore
	$0.03 < W \leq 0.05$	$L \leq 3.0$	$N \leq 2$		
	$0.05 < W \leq 0.08$	$L \leq 2.0$	$N \leq 2$		
$0.08 < W$	Define as spot defect				

Polarizer Bubble	Zone	Acceptable Qty		
	Size (mm)	A	B	C
	$\Phi \leq 0.2$	Ignore		Ignore
	$0.2 < \Phi \leq 0.4$	2 (distance $\geq 10\text{mm}$)		
	$0.4 < \Phi \leq 0.6$	1		
$0.6 < \Phi$	0			

SMT	According to IPC-A-610C class II standard . Function defect and missing part are major defect ,the others are minor defect.
-----	---

TP bubble/ accidental spot	Size Φ (mm)	Acceptable Qty		
		A	B	C
	$\Phi \leq 0.1$	Ignore		Ignore
	$0.1 < \Phi \leq 0.2$	2 (distance $\geq 10\text{m}$)		
	$0.2 < \Phi \leq 0.3$	1		
$0.3 < \Phi$	0			
Assembly deflection	beyond the edge of backlight $\leq 0.15\text{mm}$			

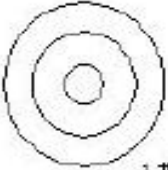
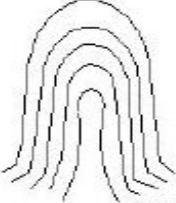

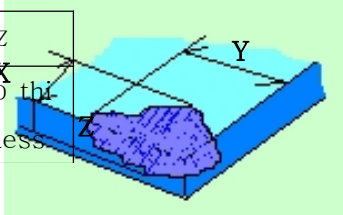
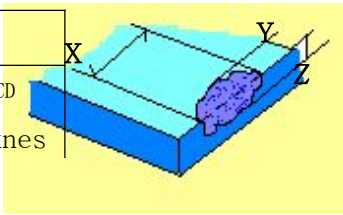
5.0	TP Related	Newton Ring	<p>Newton Ring area > 1/3 TP area NG</p> <p>Newton Ring area ≤ 1/3 TP area OK</p>	 <p>1 规律性</p>  <p>2 非规律性</p>  <p>似牛顿环</p>				
	TP corner broken	<p>X : length</p> <p>Y : width</p> <p>Z : height</p>	<table border="1" data-bbox="593 1093 887 1245"> <tr> <td>X</td> <td>Y</td> </tr> <tr> <td>X ≤ 3.0mm</td> <td>Y ≤ 3.0mm</td> </tr> </table> <p>* Circuitry broken is not allowed.</p>	X	Y	X ≤ 3.0mm	Y ≤ 3.0mm	
X	Y							
X ≤ 3.0mm	Y ≤ 3.0mm							
	TP edge broken	<p>X : length</p> <p>Y : width</p> <p>Z : height</p>	<table border="1" data-bbox="593 1429 887 1581"> <tr> <td>X</td> <td>Y</td> </tr> <tr> <td>X ≤ 6.0mm</td> <td>Y ≤ 2.0mm</td> </tr> </table> <p>* Circuitry broken is not allowed.</p>	X	Y	X ≤ 6.0mm	Y ≤ 2.0mm	
X	Y							
X ≤ 6.0mm	Y ≤ 2.0mm							



Criteria (functional items)

Number	Items	Criteria (mm)
1	No display	Not allowed
2	Missing segment	Not allowed
3	Short	Not allowed
4	Backlight no lighting	Not allowed
5	TP no function	Not allowed

8. Reliability Test Result

8.1 Condition

Item	Condition	Sample Size	Test Result	Note
Low Temperature Operating Life test	-20℃, 96HR	3ea	pass	-
Thermal Humidity Operating Life test	60℃, 90%RH, 96HR	3ea	pass	-
Temperature Cycle ON/OFF test	-20℃ ↔ 70℃, ON/OFF, 20CYC	3ea	pass	(1)
High Temperature Storage test	80℃, 96HR	3ea	pass	-
Low Temperature Storage test	- 30℃, 96HR	3ea	pass	-

Part. No	KD020C-1 V2	REV	V1.0	Page 23 of 25
----------	-------------	-----	------	---------------

常备库存
Standing Stock

长期供货
Long Availability

支持少量
NO MOQ

品种齐全
In Full Range



Thermal Shock Resistance	The sample should be allowed to stand the following 5 cycles of operation: TSTL for 30 minutes -> normal temperature for 5 minutes -> TSTH for 30 minutes -> normal temperature for 5 minutes, as one cycle, then taking it out and drying it at normal temperature, and allowing it stand for 24 hours	3ea	pass	
Box Drop Test	1 Corner 3 Edges 6 faces, 66cm(MEDIUM BOX)	1box	pass	-

Note (1) ON Time over 10 seconds, OFF Time under 10 seconds

9. Cautions and Handling Precautions

9.1 Handling and Operating the Module

(1) When the module is assembled, it should be attached to the system firmly.

Do not warp or twist the module during assembly work.

(2) Protect the module from physical shock or any force. In addition to damage, this may cause improper operation or damage to the module and back-light unit.

(3) Note that polarizer is very fragile and could be easily damaged. Do not press or scratch the surface.

(4) Do not allow drops of water or chemicals to remain on the display surface.

If you have the droplets for a long time, staining and discoloration may occur.

(5) If the surface of the polarizer is dirty, clean it using some absorbent cotton or soft cloth.

(6) The desirable cleaners are water, IPA (Isopropyl Alcohol) or Hexane.

Do not use ketene type materials (ex. Acetone), Ethyl alcohol, Toluene, Ethyl acid or Methyl chloride. It might permanent damage to the polarizer due to chemical reaction.

(7) If the liquid crystal material leaks from the panel, it should be kept away from the eyes or mouth. In case of contact

Part. No	KD020C-1 V2	REV	V1.0	Page 24 of 25
----------	-------------	-----	------	---------------

常备库存
Standing Stock

长期供货
Long Availability

支持少量
NO MOQ

品种齐全
In Full Range



with hands, legs, or clothes, it must be washed away thoroughly with soap.

- (8) Protect the module from static; it may cause damage to the CMOS ICs.
- (9) Use finger-stalls with soft gloves in order to keep display clean during the incoming inspection and assembly process.
- (10) Do not disassemble the module.
- (11) Protection film for polarizer on the module shall be slowly peeled off just before use so that the electrostatic charge can be minimized.
- (12) Pins of I/F connector shall not be touched directly with bare hands.
- (13) Do not connect, disconnect the module in the "Power ON" condition.
- (14) Power supply should always be turned on/off by the item 6.1 Power On Sequence & 6.2 Power Off Sequence

9.2 Storage and Transportation.

- (1) Do not leave the panel in high temperature, and high humidity for a long time.
It is highly recommended to store the module with temperature from 0 to 35 °C and relative humidity of less than 70%
- (2) Do not store the TFT-LCD module in direct sunlight.
- (3) The module shall be stored in a dark place. When storing the modules for a long time, be sure to adopt effective measures for protecting the modules from strong ultraviolet radiation, sunlight, or fluorescent light.
- (4) It is recommended that the modules should be stored under a condition where no condensation is allowed. Formation of dewdrops may cause an abnormal operation or a failure of the module.
In particular, the greatest possible care should be taken to prevent any module from being operated where condensation has occurred inside.
- (5) This panel has its circuitry FPC on the bottom side and should be handled carefully in order not to be stressed.

10.Packing

-----TBD-----

Part. No	KD020C-1 V2	REV	V1.0	Page 25 of 25
	常备库存 Standing Stock	长期供货 Long Availability	支持小量 NO MOQ	品种齐全 In Full Range