



**SPECIFICATION
FOR
LCD Module
KD020C-2A-xxx**

MODULE:	KD020C-2A-xxx
CUSTOMER:	

REV	DESCRIPTION	DATE
1.0	FIRST ISSUE	2018.03.23

STARTEK	INITIAL	DATE
PREPARED BY		
CHECKED BY		
APPROVED BY		

CUSTOMER	INITIAL	DATE
APPROVED BY		

Part. No	KD020C-2A-xxx	REV	V1.0	Page 1 of 23
-----------------	----------------------	------------	-------------	---------------------

常备库存
Standing Stock

长期供货
Long Time supply

支持小量
NO MOQ

品种齐全
In Full Range



Contents

General Description	4
1. Block Diagram	5
2. Outline dimension	6
3. Input Terminal Pin Assignment	7
4. LCD Optical Characteristics	9
5. Electrical Characteristics	11
6. AC Characteristic	12
7. LCD Module Out-Going Quality Level	15
8. Reliability Test Result	21
9. Cautions and Handling Precautions	22
10. Packing	23

Part. No	KD020C-2A-xxx	REV	V1.0	Page 3 of 23
	常备库存 Standing Stock	长期供货 Long Time supply	支持少量 NO MOQ	品种齐全 In Full Range



General Description

* Description

This is a color active matrix TFT (Thin Film Transistor) LCD (liquid crystal display) that uses amorphous silicon TFT as a switching device. This model is composed of a Transmissive type TFT-LCD Panel, driver circuit, back-light unit. The resolution of a 2.0" TFT-LCD contains 176x220 pixels, and can display up to 65/262K colors.

* Features

- Low Input Voltage: 3.3V(TYP)
- Display Colors of TFT LCD: 65/262K Colors
- Interface: MCU 8/9/16/18Bit;3/4SPI

General Information Items	Specification	Unit	Note
	Main Panel		
Display area(AA)	31.68(H)*39.6(V)(2.0inch)	mm	-
Driver element	TFT active matrix	-	-
Display colors	65K/262K	colors	-
Number of pixels	176(RGB)*220	dots	-
Pixel arrangement	RGB vertical stripe	-	-
Pixel pitch	0.180(H)*0.180 (V)	mm	-
Viewing angle	Free viewing angle		-
Controller IC	ST7775R	-	-
Display mode	Transmissive/ Normally black	-	-
Operating temperature	-20~+70	°C	-
Storage temperature	-30~+80	°C	-

* Mechanical Information

Item		Min.	Typ.	Max.	Unit	Note
Module size	Horizontal(H)		38.4		mm	-
	Vertical(V)		51.4		mm	-
	Depth(D)		2.35		mm	-
Weight			TBD		g	-

Part. No	KD020C-2A-xxx	REV	V1.0	Page 4 of 23
----------	---------------	-----	------	--------------

常备库存
Standing Stock

长期供货
Long Time supply

支持小量
NO MOQ

品种齐全
In Full Range



1. Block Diagram

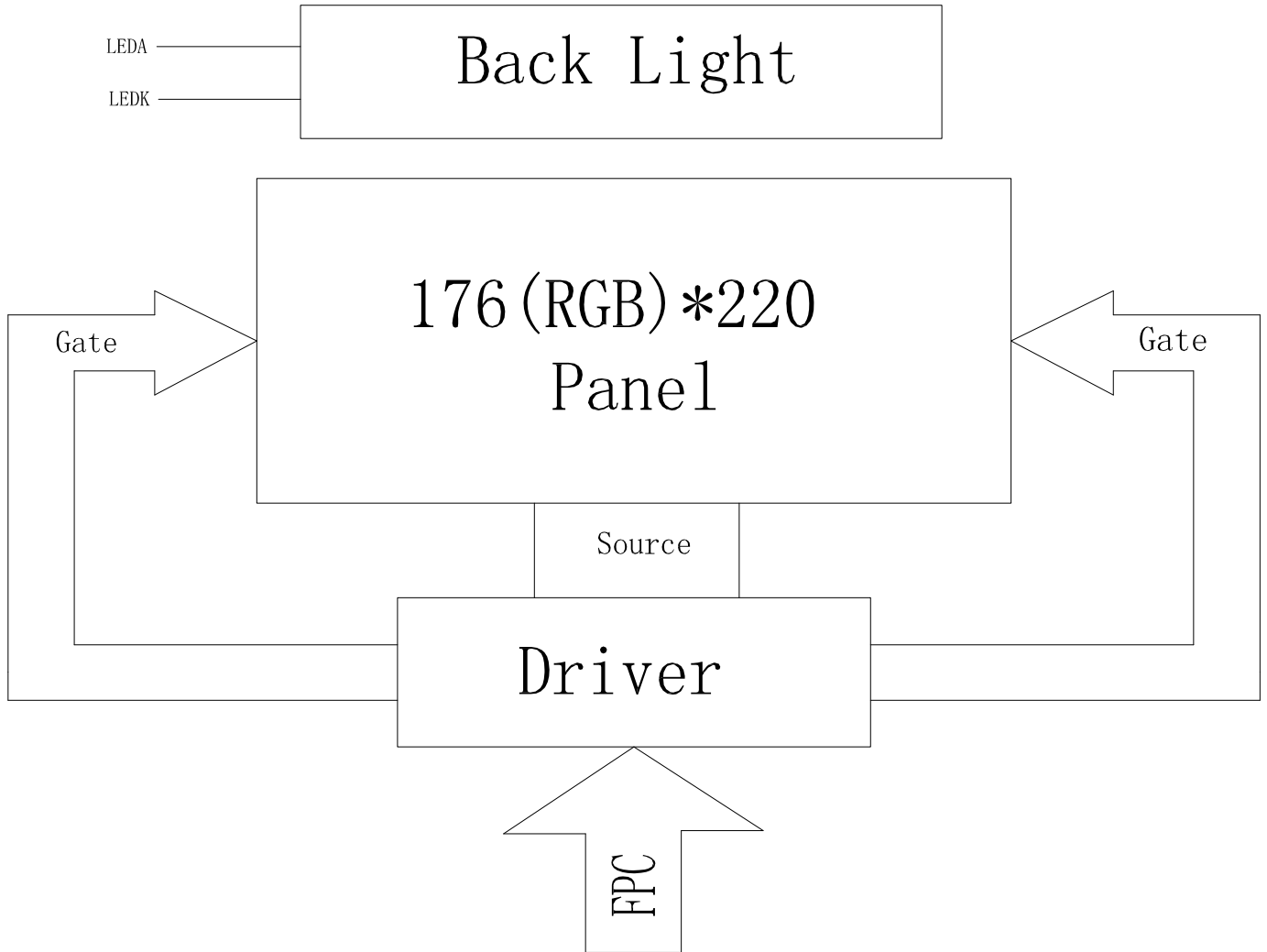

2. Outline dimension

Part. No	KD020C-2A-xxx	REV	V1.0	Page 5 of 23
	常备库存 Standing Stock	长期供货 Long Time supply	支持小量 NO MOQ	品种齐全 In Full Range

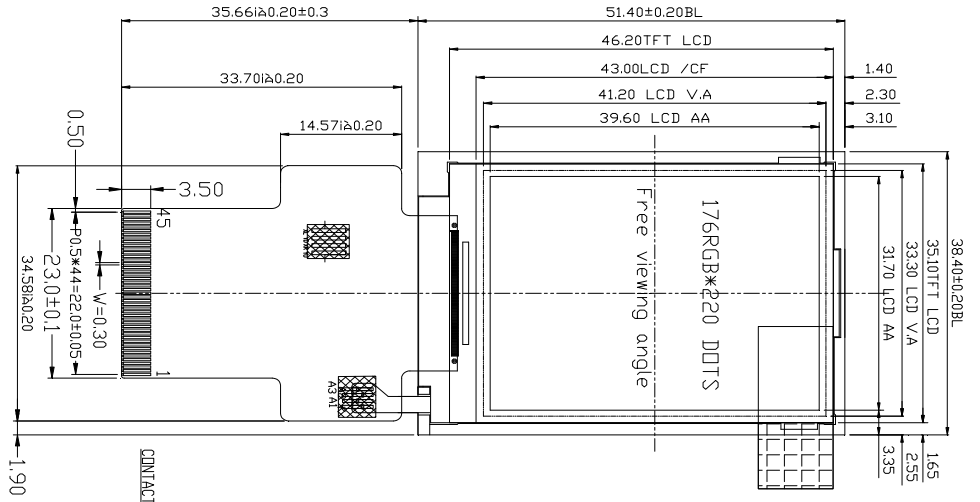

此款产品使用簿偏光片

- NOTES:
1. DISPLAY TYPE: 2.0", TFT-LCD, 65K/262K COLORS
 2. DISPLAY MODE: NORMALLY black
 3. VIEWING DIRECTION: Free viewing angle
 4. DRIVER IC: ST7775R (COG)
 5. VCI/VCCIO: 3.3V(TYP)
 6. OPERATING TEMP: -20°C TO 70°C
 7. STORAGE TEMP: -30°C TO 80°C
 8. BACK LIGHT: LED WHITE, 3 LED, 45mA, 3.2±0.3V
 9. RoHS COMPLIANT.

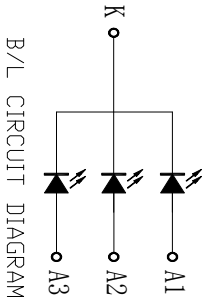

注：上机壳开窗须小于LCD/CF 0.3mm以上，
LCD V.A为镜片建议开窗尺寸！

NOTE:
1. If not use PIN fix to the GND, 10WCC or 'NC' interface
2. If 'use RGB mode must select serial interface

1#3	1#2	1#0	Interface type	DB Pin in use
0	0	1	DB1 7Pin, 8-bit interface	DB17-DB10
0	0	0	DB1 7Pin, 8-bit interface	DB17-DB10
0	0	0	DB1 7Pin, 16-bit interface DBS-DB1	DB17-DB10
1	0	1	DB1 7Pin, 9-bit interface	DB17-DB9
1	0	0	DB1 7Pin, 18-bit interface	DB17-DB0
0	1	0	3-Wire 9 BIT data serial interface	SDI SCL CS
0	1	1	4-Wire 8 BIT data serial interface	SDI SCL CS RS

此点设计时注意PC开窗！
FPC弯折参考图
PFC展开出货

Pin Name	1	2	3	4	5	6	7	8	9	10	11	12	13	14	15	16	17	18	19	20	21	22	23	24	25	26	27	28	29	30	31	32	33	34	35	36	37	38	39	40	41	42	43	44	45
GND	VCC	VCCIO	RS	CS	VSYNC	HSYNC	DOTCLK	DEN	RESET	SOT	RD	WR	DB17	DB16	DB15	DB14	DB13	DB12	DB11	DB10	DB9	DB8	DB7	DB6	DB5	DB4	DB3	DB2	DB1	DB0	IM3	IM2	IM0	SDD	SDD	LEDB	LED1A	LED2A	LED3A	Y(UNC)	Y(UNC)	X(UNC)	X(UNC)	GND	

Rev	Revision content description	Date
A	FIRST	2018/03/23

深圳市柯达科电子科技有限公司
SHENZHEN STARTEK ELECTRONICS CO., LTD

TOLERANCE(公差)

DRAWING NAME	PARTS NO.	UNIT
KD020C-2A-XXX		mm

TOLERANCE UNLESS OTHERWISE SPECIFIED X.XX±0.3 X.XX±0.2

Scale 1:1

Checked
Drawn
Approve



3. Input terminal Pin Assignment

NO.	SYMBOL	DISCRIPTION	I/O
1	GND	Ground.	P
2	VCC	Supply voltage (3.3V).	P
3	VCCIO	Supply voltage for IO(1.8V/3.3V).	P
4	RS	Display data / Command selection pin.	I
5	CS	Chip select input pin ("Low" enable). This pin can be permanently fixed "Low" in MCU interface mode only.	I
6	VSYNC	Frame synchronizing signal for RGB interface operation. fix this pin at GND when not in use.	I
7	HSYNC	Line synchronizing signal for RGB interface operation. fix this pin at GND when not in use.	I
8	DOTCLK	Dot clock signal for RGB interface operation. Fix this pin at GND when not in use.	I
9	DEN	Data enable signal for RGB interface operation fix this pin at GND when not in use.	I
10	RESET	This signal will reset the device and must be applied to properly initialize the chip.	I
11	SDI	Data lane serial interface. fix this pin at GND when not in use.	I
12	RD	Serves as a read signal and MCU read data at the rising edge. fix this pin at VCI or GND when not in use.	I
13	WR	Write enable in parallel interface.	II
14-31	DB17-DB0	Data bus.	I/O
32	IM3	MPU Parallel interface bus and serial interface select If use RGB Int erface must select serial interface. Fix this pin at VCI and GND.	I
33	IM2		I
34	IM0		I
35	SDO	SPI interface output pin. -The data is output on the falling edge of the SCL signal.	O

Part. No	KD020C-2A-xxx	REV	V1.0	Page 7 of 23
----------	---------------	-----	------	--------------

常备库存
Standing Stock

长期供货
Long Time supply

支持小量
NO MOQ

品种齐全
In Full Range



		-If not used, let this pin open.	
36	GND	Ground.	
37	LEDK	Cathode pin OF backlight.	P
38	LEDA1	Anode pin of backlight.	P
39	LEDA2	Anode pin of backlight.	P
40	LEDA3	Anode pin of backlight.	P
41	YU(NC)	Touch panel Top Film Terminal	A/D
42	XR(NC)	Touch panel Right Glass Terminal	A/D
43	YD(NC)	Touch panel Bottom Film Terminal	A/D
44	XL(NC)	Touch panel LIFT Glass Terminal	A/D
45	GND	Ground.	P



4. LCD Optical Characteristics

4.1 Optical specification

Item	Symbol	Condition	Min.	Typ.	Max.	Unit	Note
Transmittance (without Polarizer)	T(%)	—	—	16.0	—	—	
Contrast Ratio	CR	$\Theta=0$	400	500	—	—	(1)(2)
Response time	Rising	T_R	—	2	4	msec	(1)(3)
	Falling	T_F	—	6	12		
Color gamut	S(%)			60		%	
Color chromaticity (CIE1931)	White	W_x		0.283	0.303	0.323	(1)(4) CF glass
		W_y		0.305	0.325	0.345	
	Red	R_x		0.606	0.626	0.646	
		R_y		0.314	0.334	0.354	
	Green	G_x		0.257	0.277	0.397	
		G_y		0.529	0.549	0.569	
	Blue	B_x		0.122	0.142	0.162	
		B_y		0.102	0.122	0.142	
Viewing angle	Hor.	Θ_L	CR>10	35	45	—	
		Θ_R		35	45	—	
	Ver.	Θ_U		35	45	—	
		Θ_D		10	20	—	
Optima View Direction	12 O'clock						(5)

4.2 Measuring Condition

- Measuring surrounding : dark room
- Ambient temperature : $25\pm 2^{\circ}\text{C}$
- 15min. warm-up time.

Part. No	KD020C-2A-xxx	REV	V1.0	Page 9 of 23
	常备库存 Standing Stock	长期供货 Long Time supply	支持小量 NO MOQ	品种齐全 In Full Range



4.3 Measuring Equipment

- FPM520 of Westar Display technologies, INC., which utilized SR-3 for Chromaticity and BM-5A for other optical characteristics.

Note (1) Definition of Viewing Angle :

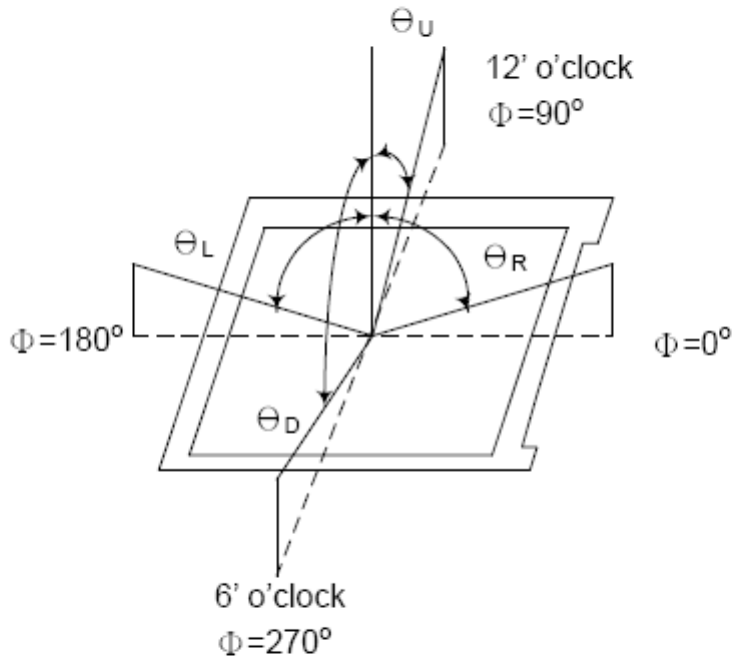

Note (2) Definition of Contrast Ratio(CR) :
measured at the center point of panel

$$CR = \frac{\text{Luminance with all pixels white}}{\text{Luminance with all pixels black}}$$

Part. No	KD020C-2A-xxx	REV	V1.0	Page 10 of 23
	常备库存 Standing Stock	长期供货 Long Time supply	支持小量 NO MOQ	品种齐全 In Full Range



5. Electrical Characteristics

5.1 Absolute Maximum Rating (Ta=25 VSS=0V)

Characteristics	Symbol	Min.	Max.	Unit
Digital Supply Voltage	VDD	-0.3	4.6	V
Digital interface supply Voltage	VDDIO	-0.3	4.6	V
Operating temperature	T _{OP}	-20	+70	°C
Storage temperature	T _{ST}	-30	+80	°C

5.2 DC Electrical Characteristics

Characteristics	Symbol	Min.	Typ.	Max.	Unit	Note
Digital Supply Voltage	VDD	2.5	3.3	4.2	V	
Digital interface supply Voltage	VDDIO	1.65	3.3	4.2	V	
Normal mode Current consumption	IDD	--	2.5	--	mA	
Level input voltage	V _{IH}	0.8V _{DDIO}		V _{DDIO}	V	
	V _{IL}	GND		0.3V _{DDIO}	V	
Level output voltage	V _{OH}	0.8V _{DDIO}		V _{DDIO}	V	
	V _{OL}	GND		0.2V _{DDIO}	V	

5.3 LED Backlight Characteristics

The back-light system is edge-lighting type with 3 chips White LED

Item	Symbol	Min.	Typ.	Max.	Unit	Note
Forward Current	I _F	45	60	--	mA	
Forward Voltage	V _F	--	3.2	--	V	
LCM Luminance	L _v	200	--	--	cd/m ²	I _F =60mA
Uniformity	AV _g	80	--	--	%	

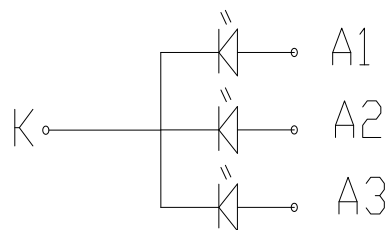

LED CIRCUIT DIAGRAM

Part. No	KD020C-2A-xxx	REV	V1.0	Page 11 of 23
----------	---------------	-----	------	---------------

常备库存
Standing Stock

长期供货
Long Time supply

支持小量
NO MOQ

品种齐全
In Full Range



6. AC Characteristic

6.1. Display Parallel 18/16/9/8-bit Interface Timing Characteristics (8080- system)

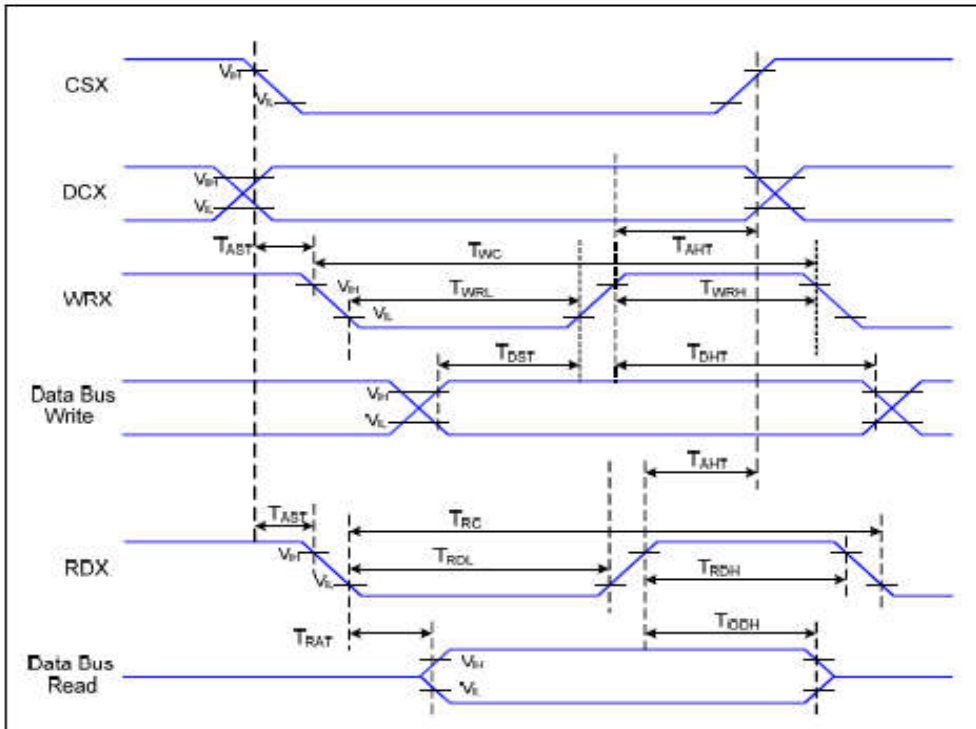

Figure 1 Parallel Interface Timing Characteristics (8080-Series MCU Interface)

$V_{DD1}=1.65$ to $3.3V$, $V_{DD}=2.5$ to $3.3V$, $AGND=DGND=0V$, $T_a=25$ °C

Signal	Symbol	Parameter	Min	Max	Unit	Description
DCX	TAST	Address Setup Time	10	-	ns	
	TAHT	Address Hold Time (Write/Read)	5	-	ns	
WRX	TWC	Write Cycle	70	-	ns	
	TWRH	Control Pulse "H" Duration	35	-	ns	
	TWRL	Control Pulse "L" Duration	35	-	ns	
RDX	TRC	Read Cycle (ID)	300	-	ns	When Read ID Data
	TRDH	Control Pulse "H" Duration (ID)	150	-	ns	
	TRDL	Control Pulse "L" Duration (ID)	150	-	ns	
DB[17:0]	TDST	Data Setup Time	10	-	ns	TRAT, TRATFM: 3K ohm Pull up or Down and 30pF Parallel Cap. To GND. TODH: 3K ohm Pull up or Down.
	TDHT	Data Hold Time	15	-	ns	
	TRAT	Read Access Time (ID)	-	100	ns	
	TODH	Output Disable Time	50	-	ns	

Part. No	KD020C-2A-xxx	REV	V1.0	Page 12 of 23
----------	---------------	-----	------	---------------

常备库存
Standing Stock

长期供货
Long Time supply

支持小量
NO MOQ

品种齐全
In Full Range

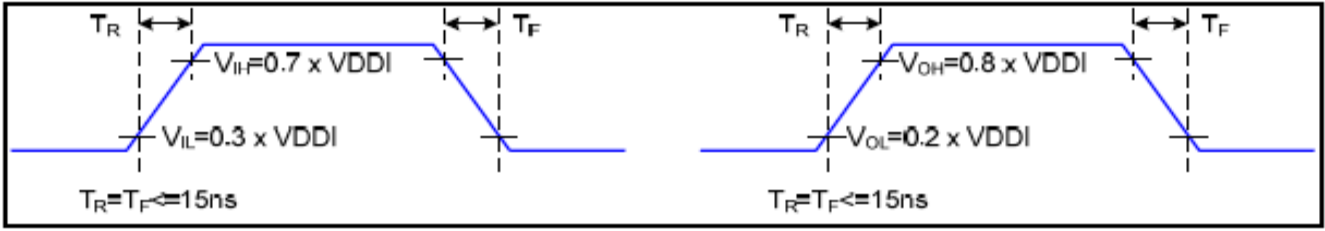

Figure 2 Rising and Falling Timing for I/O Signal

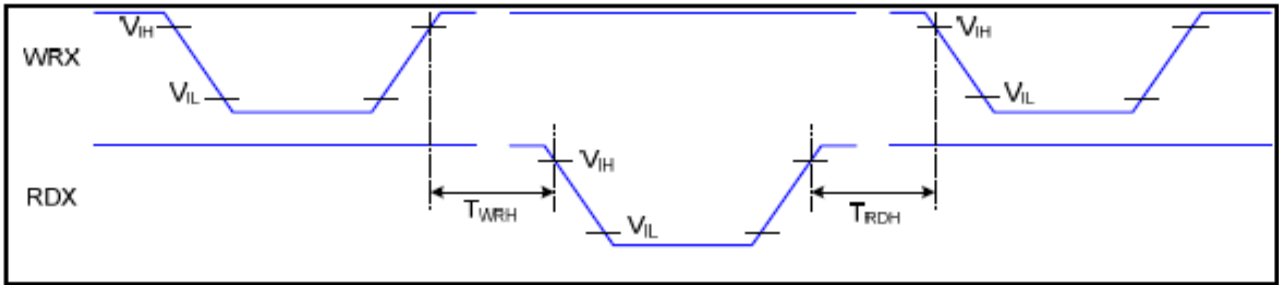
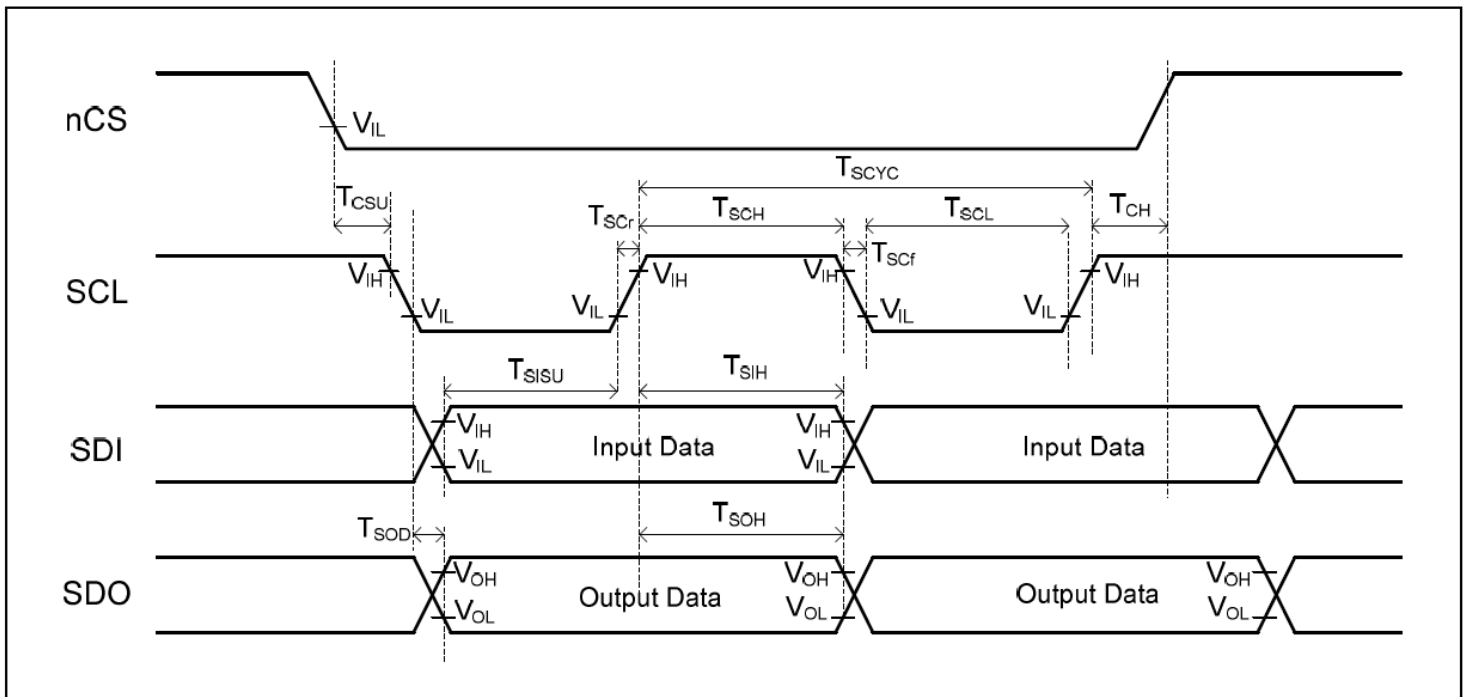

Figure 3 Write-to-Read and Read-to-Write Timing

Note: The rising time and falling time (T_r , T_f) of input signal and fall time are specified at 15 ns or less. Logic high and low levels are specified as 30% and 70% of VDDI for Input signals.

6.2 Display Serial Interface Timing Characteristics (3-line SPI system)



Part. No	KD020C-2A-xxx	REV	V1.0	Page 13 of 23
	常备库存 Standing Stock	长期供货 Long Time supply	支持小量 NO MOQ	品种齐全 In Full Range



Signal	Symbol	Parameter	Min	Max	Unit	Description
CSX	TCSU	Chip Select Setup Time	10		ns	
	TCH	Chip Select Hold Time	50		ns	
SCL	TSCr ,TSCf	Serial clock rise/fall time		5	ns	
	TSCH	SCL "H" pulse width (Write)	40		ns	
	TSCH	SCL "H" pulse width (Read)	100		ns	
	TSCYC	Serial clock cycle (Write)	80		ns	
	TSCYC	Serial clock cycle (Read)	200		ns	
	TSCL	SCL "L" pulse width (Write)	40		ns	
	TSCL	SCL "L" pulse width (Read)	100		ns	
SDI	TSISU	Serial Input Data Setup Time	20		ns	
	TSIH	Serial Input Data Hold Time	20		ns	
SDO	TSOD	Serial Output Data Setup Time		100	ns	
	TSOH	Serial Output Data Hold Time	5		ns	



7. LCD Module Out-Going Quality Level

7.1 VISUAL & FUNCTION INSPECTION STANDARD

7.1.1 Inspection conditions

Inspection performed under the following conditions is recommended.

Temperature : 25±5℃

Humidity : 65%±10%RH

Viewing Angle : Normal viewing Angle.

Illumination: Single fluorescent lamp (300 to 700Lux)

Viewing distance:30-50cm

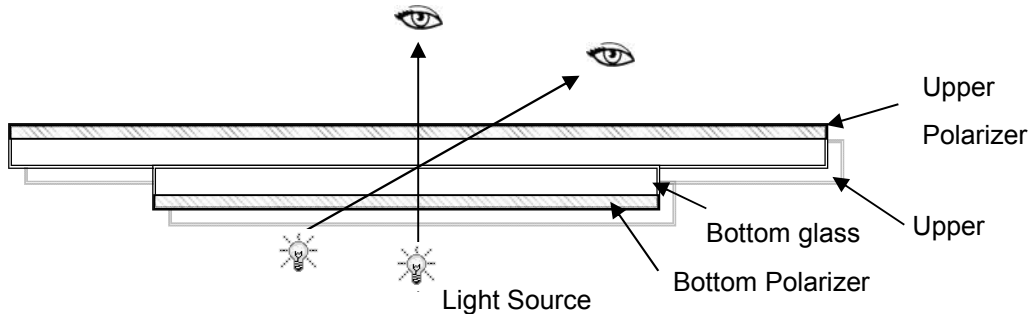

7.1.2 Definition

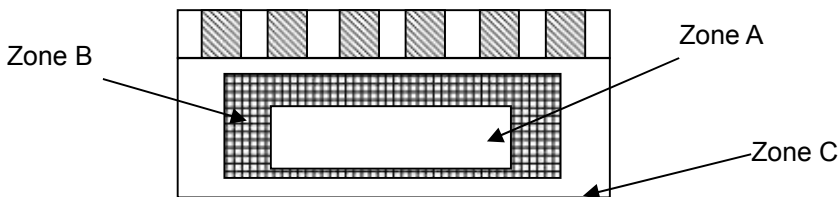

Zone A : Effective Viewing Area(Character or Digit can be seen)

Zone B : Viewing Area except Zone A

Zone C : Outside (Zone A+Zone B) which can not be seen after assembly by customer .)

Note:

As a general rule ,visual defects in Zone C can be ignored when it doesn't effect product function or appearance after assembly by customer.

7.1.3 Sampling Plan

Part. No	KD020C-2A-xxx	REV	V1.0	Page 15 of 23
	常备库存 Standing Stock	长期供货 Long Time supply	支持小量 NO MOQ	品种齐全 In Full Range



According to GB/T 2828-2003 ; , normal inspection, Class II

AQL:

Major defect	Minor defect
0.65	1.5

LCD: Liquid Crystal Display , TP: Touch Panel , LCM: Liquid Crystal Module

No	Items to be inspected	Criteria	Classification of defects
1	Functional defects	1) No display, Open or miss line 2) Display abnormally, Short 3) Backlight no lighting, abnormal lighting. 4) TP no function	Major
2	Missing	Missing component	
3	Outline dimension	Overall outline dimension beyond the drawing is not allowed	
4	Color tone	Color unevenness, refer to limited sample	Minor
5	Soldering appearance	Good soldering , Peeling off is not allowed.	
6	LCD/Polarizer/TP	Black/White spot/line, scratch, crack, etc.	



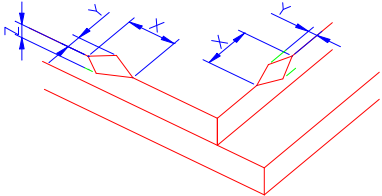
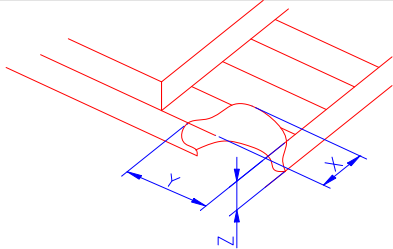
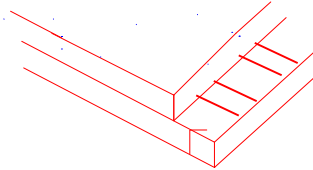

7.1.4 Criteria (Visual)

Number	Items	Criteria(mm)						
1.0 LCD Crack/Broken NOTE: X: Length Y: Width Z: Height L: Length of ITO, T: Height of LCD	(1) The edge of LCD broken	 <table border="1" data-bbox="868 640 1441 792"> <tr> <td>X</td> <td>Y</td> <td>Z</td> </tr> <tr> <td>≤3.0mm</td> <td><Inner border line of the seal</td> <td>≤T</td> </tr> </table>	X	Y	Z	≤3.0mm	<Inner border line of the seal	≤T
	X	Y	Z					
	≤3.0mm	<Inner border line of the seal	≤T					
(2)LCD corner broken	 <table border="1" data-bbox="932 1128 1377 1229"> <tr> <td>X</td> <td>Y</td> <td>Z</td> </tr> <tr> <td>≤3.0mm</td> <td>≤L</td> <td>≤T</td> </tr> </table>	X	Y	Z	≤3.0mm	≤L	≤T	
X	Y	Z						
≤3.0mm	≤L	≤T						
(3) LCD crack	 <p style="text-align: center;">Crack Not allowed</p>							

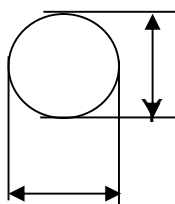

2.0	Spot defect	① light dot (LCD/TP/Polarizer black/white spot , light dot, pinhole, dent, stain)																												
	 <p>X Φ=(X+Y)/2</p>	<table border="1"> <thead> <tr> <th rowspan="2">Zone Size (mm)</th> <th colspan="3">Acceptable Qty</th> </tr> <tr> <th>A</th> <th>B</th> <th>C</th> </tr> </thead> <tbody> <tr> <td>Φ≤0.10</td> <td colspan="3">Ignore</td> </tr> <tr> <td>0.10<Φ≤0.20</td> <td colspan="3">3(distance ≥ 10mm)</td> </tr> <tr> <td>0.20<Φ≤0.25</td> <td colspan="3">2</td> </tr> <tr> <td>Φ > 0.25</td> <td colspan="3">0</td> </tr> </tbody> </table>	Zone Size (mm)	Acceptable Qty			A	B	C	Φ≤0.10	Ignore			0.10<Φ≤0.20	3(distance ≥ 10mm)			0.20<Φ≤0.25	2			Φ > 0.25	0							
Zone Size (mm)	Acceptable Qty																													
	A	B	C																											
Φ≤0.10	Ignore																													
0.10<Φ≤0.20	3(distance ≥ 10mm)																													
0.20<Φ≤0.25	2																													
Φ > 0.25	0																													
		②Dim spot (LCD/TP/Polarizer dim dot, light leakage, dark spot)																												
		<table border="1"> <thead> <tr> <th rowspan="2">Zone Size (mm)</th> <th colspan="3">Acceptable Qty</th> </tr> <tr> <th>A</th> <th>B</th> <th>C</th> </tr> </thead> <tbody> <tr> <td>Φ≤0.1</td> <td colspan="3">Ignore</td> </tr> <tr> <td>0.10<Φ≤0.20</td> <td colspan="3">3(distance ≥ 10mm)</td> </tr> <tr> <td>0.20<Φ≤0.30</td> <td colspan="3">2</td> </tr> <tr> <td>Φ > 0.30</td> <td colspan="3">0</td> </tr> </tbody> </table>	Zone Size (mm)	Acceptable Qty			A	B	C	Φ≤0.1	Ignore			0.10<Φ≤0.20	3(distance ≥ 10mm)			0.20<Φ≤0.30	2			Φ > 0.30	0							
Zone Size (mm)	Acceptable Qty																													
	A	B	C																											
Φ≤0.1	Ignore																													
0.10<Φ≤0.20	3(distance ≥ 10mm)																													
0.20<Φ≤0.30	2																													
Φ > 0.30	0																													
		③ Polarizer accidented spot																												
		<table border="1"> <thead> <tr> <th rowspan="2">Zone Size (mm)</th> <th colspan="3">Acceptable Qty</th> </tr> <tr> <th>A</th> <th>B</th> <th>C</th> </tr> </thead> <tbody> <tr> <td>Φ≤0.2</td> <td colspan="3">Ignore</td> </tr> <tr> <td>0.3<Φ≤0.5</td> <td colspan="3">2(distance ≥ 10mm)</td> </tr> <tr> <td>Φ>0.5</td> <td colspan="3">0</td> </tr> </tbody> </table>	Zone Size (mm)	Acceptable Qty			A	B	C	Φ≤0.2	Ignore			0.3<Φ≤0.5	2(distance ≥ 10mm)			Φ>0.5	0											
Zone Size (mm)	Acceptable Qty																													
	A	B	C																											
Φ≤0.2	Ignore																													
0.3<Φ≤0.5	2(distance ≥ 10mm)																													
Φ>0.5	0																													
	Line defect (LCD/TP /Polarizer black/white line, scratch, stain)	<table border="1"> <thead> <tr> <th rowspan="2">Width(mm)</th> <th rowspan="2">Length(mm)</th> <th colspan="3">Acceptable Qty</th> </tr> <tr> <th>A</th> <th>B</th> <th>C</th> </tr> </thead> <tbody> <tr> <td>Φ≤0.03</td> <td>Ignore</td> <td colspan="3">Ignore</td> </tr> <tr> <td>0.03<W≤0.05</td> <td>L≤3.0</td> <td colspan="3">N≤2</td> </tr> <tr> <td>0.05<W≤0.08</td> <td>L≤2.0</td> <td colspan="3">N≤2</td> </tr> <tr> <td>0.08<W</td> <td colspan="4">Define as spot defect</td> </tr> </tbody> </table>	Width(mm)	Length(mm)	Acceptable Qty			A	B	C	Φ≤0.03	Ignore	Ignore			0.03<W≤0.05	L≤3.0	N≤2			0.05<W≤0.08	L≤2.0	N≤2			0.08<W	Define as spot defect			
Width(mm)	Length(mm)	Acceptable Qty																												
		A	B	C																										
Φ≤0.03	Ignore	Ignore																												
0.03<W≤0.05	L≤3.0	N≤2																												
0.05<W≤0.08	L≤2.0	N≤2																												
0.08<W	Define as spot defect																													

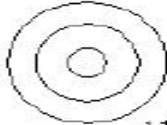

3.0	Polarizer Bubble	<table border="1"> <tr> <th rowspan="2">Zone Size (mm)</th> <th colspan="3">Acceptable Qty</th> </tr> <tr> <th>A</th> <th>B</th> <th>C</th> </tr> <tr> <td>$\Phi \leq 0.2$</td> <td colspan="3">Ignore</td> </tr> <tr> <td>$0.2 < \Phi \leq 0.4$</td> <td colspan="3">3 (distance ≥ 10 m)</td> </tr> <tr> <td>$0.4 < \Phi \leq 0.6$</td> <td colspan="3">2</td> </tr> <tr> <td>$0.6 < \Phi$</td> <td colspan="3">0</td> </tr> </table>			Zone Size (mm)	Acceptable Qty			A	B	C	$\Phi \leq 0.2$	Ignore			$0.2 < \Phi \leq 0.4$	3 (distance ≥ 10 m)			$0.4 < \Phi \leq 0.6$	2			$0.6 < \Phi$	0			
		Zone Size (mm)	Acceptable Qty																									
			A	B	C																							
		$\Phi \leq 0.2$	Ignore																									
		$0.2 < \Phi \leq 0.4$	3 (distance ≥ 10 m)																									
$0.4 < \Phi \leq 0.6$	2																											
$0.6 < \Phi$	0																											
4.0	SMT	According to IPC-A-610C class II standard . Function defect and missing part are major defect ,the others are minor defect.																										
5.0	TP Related	TP bubble/ accidented spot	<table border="1"> <tr> <th rowspan="2">Size Φ(mm)</th> <th colspan="3">Acceptable Qty</th> </tr> <tr> <th>A</th> <th>B</th> <th>C</th> </tr> <tr> <td>$\Phi \leq 0.1$</td> <td colspan="3">Ignore</td> </tr> <tr> <td>$0.1 < \Phi \leq 0.25$</td> <td colspan="3">3 (distance \geq</td> </tr> <tr> <td>$0.25 < \Phi \leq 0.3$</td> <td colspan="3">2</td> </tr> <tr> <td>$0.3 < \Phi$</td> <td colspan="3">0</td> </tr> </table>			Size Φ (mm)	Acceptable Qty			A	B	C	$\Phi \leq 0.1$	Ignore			$0.1 < \Phi \leq 0.25$	3 (distance \geq			$0.25 < \Phi \leq 0.3$	2			$0.3 < \Phi$	0		
			Size Φ (mm)	Acceptable Qty																								
				A	B	C																						
			$\Phi \leq 0.1$	Ignore																								
$0.1 < \Phi \leq 0.25$	3 (distance \geq																											
$0.25 < \Phi \leq 0.3$	2																											
$0.3 < \Phi$	0																											
Assembly deflection	beyond the edge of backlight ≤ 0.15 mm																											
Newton Ring	<p>Newton Ring area $> 1/3$ TP area NG</p> <p>Newton Ring area $\leq 1/3$ TP area OK</p>	 1 规律性  2 非规律性  似牛顿环																										

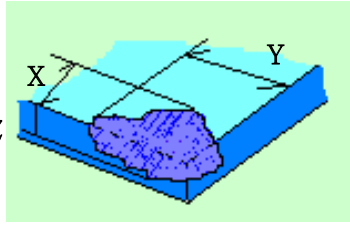
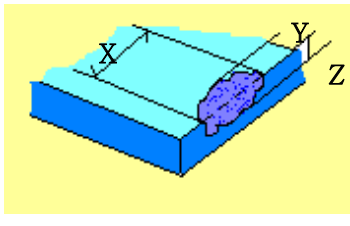

		TP corner broken	<table border="1"> <tr> <td>X</td> <td>Y</td> <td>Z</td> </tr> <tr> <td>$X \leq 3.0\text{mm}$</td> <td>$Y \leq 3.0\text{mm}$</td> <td>$Z < \text{LCD thickness}$</td> </tr> </table>	X	Y	Z	$X \leq 3.0\text{mm}$	$Y \leq 3.0\text{mm}$	$Z < \text{LCD thickness}$	
		X	Y	Z						
$X \leq 3.0\text{mm}$	$Y \leq 3.0\text{mm}$	$Z < \text{LCD thickness}$								
X : length Y : width Z : height	* Circuitry broken is not allowed.									
		TP edge broken	<table border="1"> <tr> <td>X</td> <td>Y</td> <td>Z</td> </tr> <tr> <td>$X \leq 6.0\text{mm}$</td> <td>$Y \leq 2.0\text{mm}$</td> <td>$Z < \text{LCD thickness}$</td> </tr> </table>	X	Y	Z	$X \leq 6.0\text{mm}$	$Y \leq 2.0\text{mm}$	$Z < \text{LCD thickness}$	
		X	Y	Z						
$X \leq 6.0\text{mm}$	$Y \leq 2.0\text{mm}$	$Z < \text{LCD thickness}$								
X : length Y : width Z : height	* Circuitry broken is not allowed.									

Criteria (functional items)

Number	Items	Criteria (mm)
1	No display	Not allowed
2	Missing segment	Not allowed
3	Short	Not allowed
4	Backlight no lighting	Not allowed
5	TP no function	Not allowed



8. Reliability Test Result

8.1 Condition

Item	Condition	Sample Size	Test Result	Note
Low Temperature Operating Life test	-20°C, 96HR	3ea	pass	-
Thermal Humidity Operating Life test	60°C, 90%RH, 96HR	3ea	pass	-
Temperature Cycle ON/OFF test	-20°C ↔ 70°C, ON/OFF, 20CYC	3ea	pass	(1)
High Temperature Storage test	80°C, 96HR	3ea	pass	-
Low Temperature Storage test	- 30°C, 96HR	3ea	pass	-
Thermal Shock Resistance	The sample should be allowed to stand the following 5 cycles of operation: TSTL for 30 minutes -> normal temperature for 5 minutes -> TSTH for 30 minutes -> normal temperature for 5 minutes, as one cycle, then taking it out and drying it at normal temperature, and allowing it stand for 24 hours	3ea	pass	
Box Drop Test	1 Corner 3 Edges 6 faces, 66cm(MEDIUM BOX)	1box	pass	-

Note (1) ON Time over 10 seconds, OFF Time under 10 seconds

Part. No	KD020C-2A-xxx	REV	V1.0	Page 21 of 23
	常备库存 Standing Stock	长期供货 Long Time supply	支持小量 NO MOQ	品种齐全 In Full Range



9. Cautions and Handling Precautions

9.1 Handling and Operating the Module

(1) When the module is assembled, it should be attached to the system firmly.

Do not warp or twist the module during assembly work.

(2) Protect the module from physical shock or any force. In addition to damage, this may cause improper operation or damage to the module and back-light unit.

(3) Note that polarizer is very fragile and could be easily damaged. Do not press or scratch the surface.

(4) Do not allow drops of water or chemicals to remain on the display surface.

If you have the droplets for a long time, staining and discoloration may occur.

(5) If the surface of the polarizer is dirty, clean it using some absorbent cotton or soft cloth.

(6) The desirable cleaners are water, IPA (Isopropyl Alcohol) or Hexane.

Do not use ketene type materials (ex. Acetone), Ethyl alcohol, Toluene, Ethyl acid or Methyl chloride. It might permanent damage to the polarizer due to chemical reaction.

(7) If the liquid crystal material leaks from the panel, it should be kept away from the eyes or mouth. In case of contact with hands, legs, or clothes, it must be washed away thoroughly with soap.

(8) Protect the module from static; it may cause damage to the CMOS ICs.

(9) Use finger-stalls with soft gloves in order to keep display clean during the incoming inspection and assembly process.

(10) Do not disassemble the module.

(11) Protection film for polarizer on the module shall be slowly peeled off just before use so that the electrostatic charge can be minimized.

(12) Pins of I/F connector shall not be touched directly with bare hands.

(13) Do not connect, disconnect the module in the "Power ON" condition.

(14) Power supply should always be turned on/off by the item 6.1 Power On Sequence & 6.2 Power Off Sequence

9.2 Storage and Transportation.

(1) Do not leave the panel in high temperature, and high humidity for a long time.

It is highly recommended to store the module with temperature from 0 to 35 °C and relative humidity of less than 70%

(2) Do not store the TFT-LCD module in direct sunlight.

(3) The module shall be stored in a dark place. When storing the modules for a long time, be sure to adopt effective measures for protecting the modules from strong ultraviolet radiation, sunlight, or fluorescent light.

(4) It is recommended that the modules should be stored under a condition where no condensation is allowed. Formation of dewdrops may cause an abnormal operation or a failure of the module.

In particular, the greatest possible care should be taken to prevent any module from being operated where condensation has occurred inside.

(5) This panel has its circuitry FPC on the bottom side and should be handled carefully in order not to be stressed.

Part. No	KD020C-2A-xxx	REV	V1.0	Page 22 of 23
	常备库存 Standing Stock	长期供货 Long Time supply	支持小量 NO MOQ	品种齐全 In Full Range



10.Packing
-----TBD-----

Part. No	KD020C-2A-xxx	REV	V1.0	Page 23 of 23
	常备库存 Standing Stock	长期供货 Long Time supply	支持少量 NO MOQ	品种齐全 In Full Range