

SK70704/SK70706

784 kbps HDSL Data Pump Chip Set

General Description

The HDSL Data Pump is a chip set consisting of the following two devices:

- SK70704 Analog Core Chip (ACC)
- SK70706 HDSL Digital Transceiver (HDX)

The HDSL Data Pump is a 2-wire transceiver which provides echo-cancelling and 2B1Q line coding. It incorporates transmit pulse shaping, filtering, line drivers, receive equalization, timing and data recovery to provide 784 kbps, clear-channel, "data pipe" transmission. The Data Pump provides Near-End Cross-Talk (NEXT) performance in excess of that required over all ANSI and ETSI test loops. Typical transmission range on 26 AWG (0.4 mm) cable exceeds 13 kft (4 km) in a noise-free environment or 9.5 kft (2.9 km) with ANSI-specified noise levels.

The Data Pump meets the requirements of Bellcore TA-NWT-001210, ANSI T1 Technical Report No. 28-1994 and ETSI ETR-152. It provides one end of a single-channel HDSL transmission system from the twisted pair interface back to the Data Pump/HDSL data interface. The Data Pump can be used at either the HTU-R or the HTU-C end of the interface.

Applications

- T1 (2-pair) and fractional T1 transport
- N-channel digital pair-gain
- Wireless base station to switch interface
- Campus and private networking
- High-Speed digital modems

Features

- Fully integrated, 2-chip set for interfacing to 2-wire HDSL lines at 784 kbps
- Single +5 V supply
- Integrated line drivers, filters and hybrid circuits result in greatly reduced external logic and simplified support circuitry requirements
- Simple line interface circuitry, via transformer coupling, to twisted pair line
- Internal ACC voltage reference
- Converts serial binary data to scrambled 2B1Q encoded data
- Self-contained activation/start-up state machine for simplified single loop designs
- Programmable for either central office (HTU-C) or remote site (HTU-R) applications
- Compliant with:
 - Bellcore TA-NWT-001210
 - ANSI HDSL Technical Report No. 28-1994
 - ETSI ETR-152 (1995)
- Design allows for operation in either Software Control or stand alone Hardware Control mode
- Typical power consumption less than 1.0 W allowing remote power feeding for repeater and HTU-R equipment
- Input or Output Reference Clock of 12.544 MHz
- Digital representation of receive signal level and noise margin values available for SNR controlled activation.

HDSL Data Pump Block Diagram

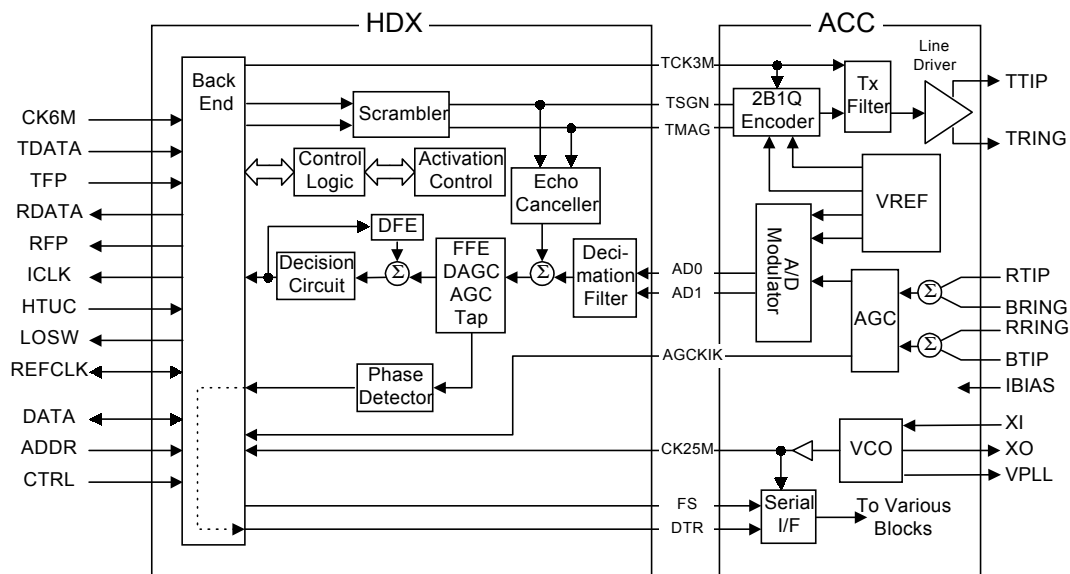

PIN ASSIGNMENTS AND SIGNAL DESCRIPTIONS

The ACC is packaged in a 28-pin PLCC. Figure 1 shows the ACC pin locations. Table 1 lists signal descriptions for each pin, except pins 18 and 19, which are not connected.

The HDX is packaged in a 44-pin PLCC. Figure 2 shows the HDX pin locations. Table 2 lists signal descriptions for each pin, including pin 29, which is not connected.

Figure 1: SK70704 ACC Pin Locations

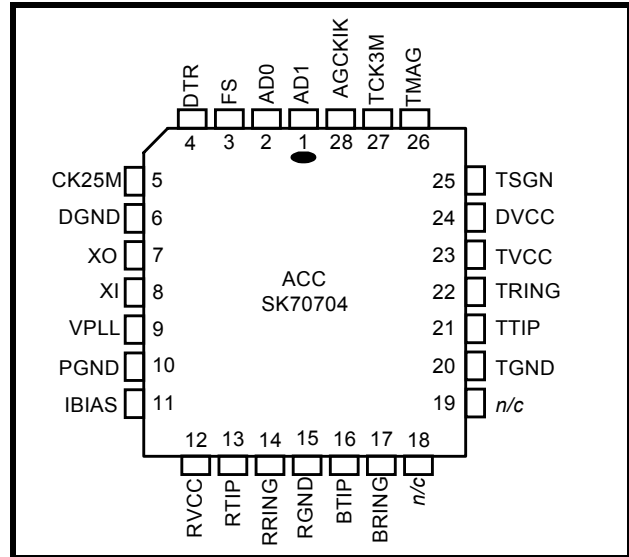

Table 1: SK70704 ACC Pin Assignments/Signal Descriptions

Group	Pin #	Symbol	I/O ¹	Description
Line	13	RTIP	AI	Receive Tip and Ring inputs. Connect these pins to the line transformer per network requirements.
	14	RRING	AI	
	16	BTIP	AI	Bias Tip and Ring. Inputs provide a bias setting for the receiver. Provide balanced network inputs.
	17	BRING	AI	
	21	TTIP	AO	Transmit Tip and Ring. Line driver outputs.
	22	TRING	AO	
PLL	7	XO	AO	Crystal Oscillator. Connect a 25.088 MHz crystal across these two pins.
	8	XI	AI	
	9	VPLL	AO	PLL Voltage Control. Supplies control voltage to the VCXO.
Power	10	PGND	S	PLL Ground. 0 V.
	12	RVCC	S	Receive Power supply. +5 V (± 5%).
	23	TVCC	S	Transmit Power supply. +5 V (± 5%).
	24	DVCC	S	Digital Power Supply. +5 V (± 5%).
	6	DGND	S	DVCC Ground. 0 V.
	15	RGND	S	RVCC Ground. 0 V.
	20	TGND	S	TVCC Ground. 0 V.

¹ I/O column entries: DI = Digital Input; DO = Digital Output; DI/O = Digital Input/Output; AI = Analog Input; AO = Analog Output; AI/O = Analog Input/Output; S = Supply.

Table 1: SK70704 ACC Pin Assignments/Signal Descriptions – continued

Group	Pin #	Symbol	I/O ¹	Description
Clock and Control	3	FS	DI	392 kHz Clock Input. From HDX FS.
	4	DTR	DI	Serial Control Data. Input from HDX at 12.544 Mbps.
	5	CK25M	DO	25.088 MHz HDSL Reference Clock. Used as the receive timing reference for the HDX. Tie to HDX CK25M.
	27	TCK3M	DI	3.136 MHz Clock. Input from HDX TCK3M.
Data Input and Output	28	AGCKIK	DO	AGC Adjust Signal. Output to HDX AGCKIK.
	1	AD1	DO	A-to-D Converter Data Line 1. Connect to HDX AD1.
	2	AD0	DO	A-to-D Converter Data Line 0. Connect to HDX AD0.
	25	TSGN	DI	Transmit Quat Sign. Input from HDX.
	26	TMAG	DI	Transmit Quat Magnitude. Input from HDX.
Analog Input	11	IBIAS	AI	Input Bias. Provides input bias current.

1 I/O column entries: DI = Digital Input; DO = Digital Output; DI/O = Digital Input/Output; AI = Analog Input; AO = Analog Output; AI/O = Analog Input/Output; S = Supply.

Figure 2: SK70706 HDX Pin Assignments

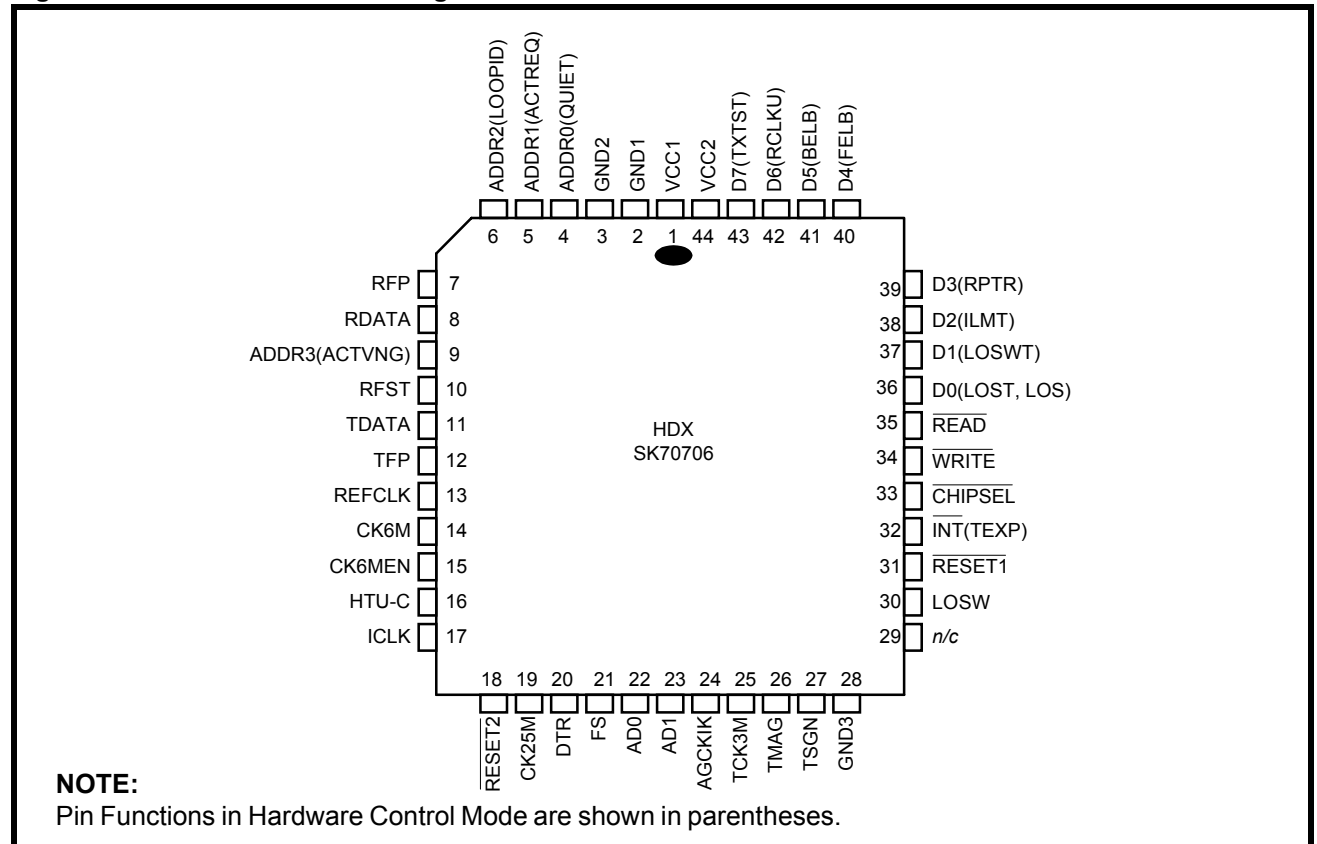

Table 2: SK70706 HDX Pin Assignments/Signal Descriptions

Group	Pin #	Symbol	I/O ⁴	Description
Power	1	VCC1	S	Logic supply input. (Refer to Table 27)
	44	VCC2	S	I/O supply input.
	2	GND1	S	Ground.
	3	GND2	S	Ground.
	28	GND3	S	Ground.
User Port	10	RFST	DO	Receive Frame and Stuff Bit Indicator. Goes High for 18 consecutive ICLK periods to indicate four stuffing bits (b4703 - 4706) and 14 frame bits (b1-14) on RDATA.
	13	REFCLK	DI ¹ DO	12.544 MHz HDSL Reference Clock. In HTU-C Mode, this clock generates transmit and receive timing and must have ±32 ppm accuracy. In HTU-R Mode, this output is derived by dividing CK25M by two.
	16	HTU-C	DI	Operation Mode Select. When HTU-C is High, the Data Pump operates in HTU-C mode; when HTU-C is Low, the Data Pump operates in HTU-R mode. Tied to internal pull-up device.
	17	ICLK	DO	Bit Rate Clock. Nominally 784 kHz, REFCLK is the source of ICLK in HTU-C Mode. CK25M is the source of ICLK in HTU-R Mode.
	30	LOSW	DO	Loss of Sync Word Indicator. Normally Low in Active States, goes High to indicate receipt of six consecutive mismatched frame synch words. LOSW is logic High in all states except Active States.
	8	RDATA	DO	Receive HDSL Data Stream. Output data to HDSL framer at 784 kbps: HDSL payload of Loop 1 or Loop 2 bytes plus the F-bits, eoc, crc, losd, febe, ps, bpv, hrp, inde/indr and uib bits, Sync bits for frame positions b1-14, Stuff bits for frame positions b4703 - 4706. RDATA bits are forced high in all states except the Active State.
	7	RFP	DO	Receive Frame Pulse. Low for one ICLK cycle during the last bit of the current HDSL receive frame on RDATA, either b4702 or b4706. Period is within one baud time of 6 ms. ² RFP is valid when LOSW transitions Low.
	11	TDATA	DI ¹	Transmit HDSL Data Stream. Input data from HDSL framer at 784 kbps: HDSL payload of Loop 1 or Loop 2 bytes plus the F-bits, eoc, crc, losd, febe, ps, bpv, hrp, inde/indr and uib bits, Sync bits for frame positions b1-14, Stuff dummy bits; may be 1s or 0s. Tied to internal pull-up device. When ACTIVE, the Data Pump is transparent and the HDSL framer must generate the appropriate bits on TDATA as shown in Table 5.
12	TFP	DI ¹	Transmit Frame Pulse. Should be Low for one ICLK cycle the during last bit of the current HDSL frame on TDATA, either b4702 or b4706. Period is within one baud time of 6 ms. ² If TFP is pulled Low and is Low again three ICLK cycles later, RDATA, RFP, RFST, ICLK, CK6MEN, and LOSW go to tri-state. Tied to internal pull-up device.	

1. This input is a Schmidt Triggered circuit and includes an internal pull-up device.
 2. The period is 6 ms ±¹/₃₉₂ ms.
 3. This input is a Schmidt Triggered circuit and includes an internal pull-down device.
 4. I/O column entries: DI = Digital Input; DO = Digital Output; DI/O = Digital Input/Output; AI = Analog Input; AO = Analog Output; AI/O = Analog Input/Output; S = Supply.

Table 2: SK70706 HDX Pin Assignments/Signal Descriptions – continued

Group	Pin #	Symbol	I/O ⁴	Description	
Hardware Interface <i>(Hardware Control Mode)</i>	4	QUIET	DI ³	Quiet Mode Enable. Pull High to force HDX into Deactivated State. Any later transition to Low will not return HDX to Active State. See ACTREQ.	
	5	ACTREQ	DI ³	Activation Request (HTU-C mode) or no function (HTU-R mode). Tie this pin Low in HTU-R mode. If QUIET is Low, a rising edge on this pin initiates activation, but the signal is ignored after activation. See QUIET.	
	6	LOOPID	DI ³ /O	Loop Number Control (HTU-C mode) or Loop Number Indicator (HTU-R mode). Low = loop 1; High = loop 2. Input Signal for HTU-C mode, output for HTU-R mode. In HTU-R mode valid only when LOSW is Low. <i>Note: The ETSI recommendation uses overhead bits for loop identification.</i>	
	9	ACTVNG	DO	Activating State Indication. High when the HDX is in the Activating State.	
	18	RESET ²	DI ¹	Reset Pulse. Pull Low on power up to initialize circuits and stop all clocks.	
	31	RESET ¹	DI ¹	Reset Pulse. Pull Low to initialize internal circuits.	
	32	TEXP	DO	Timer Expiry. Goes High to indicate 30 second timer expiration in all states.	
	33	CHIPSEL	DI ³	Chip Select <i>Assert these three pins Low to activate Hardware Control Mode. When any of them goes High, the HDX reverts immediately to Software Control Mode.</i>	
	34	WRITE	DI ³		Write Pulse
	35	READ	DI ³		Read Pulse
	36	LOST <i>(HTU-C)</i>	DO	Loss of Signal Timer Expiration. In HTU-C mode, LOST goes High when the Data Pump enters the Inactive State. The transition from the Deactivated to the Inactive State occurs 1 second after the end of transmission by the HTU-R when deactivation began from either the Active-1 or Active-2 State. When the Data Pump transitions from the Activating State to the Deactivated State it may immediately enter the Inactive State without waiting for HTU-R transmission to cease. (See Figure 6.)	
		LOS <i>(HTU-R)</i>	DO	Loss of Signal Energy Indicator. In HTU-R mode LOS goes High to indicate loss of signal energy on entering the Inactive State. (See Figure 8.)	
	37	LOSWT	DO	Loss of Sync Word Timer. LOSWT goes High when LOSW is sustained for longer than 2 sec.	
	38	ILMT	DI ¹	Insertion Loss Measurement Test. Set High to transmit a framed & scrambled, “all 1s”, 2B1Q pulse sequence. Pulse sequence will have a valid sync word. In the HTU-R configuration, when the ILMT mode is selected, the Data Pump may begin activation.	
	39	RPTR	DI ¹	Repeater Mode Enable. When in HTU-C mode, ICLK output phase is aligned to the TFP input pulse width. Ignored in HTU-R mode.	
40	FELB	DI ¹	Front-End Loopback (HTU-C only). In Inactive State, set High to cause the ACC to loopback. The returned signal activates the HDX which receives its own transmitted data. The system ignores incoming data from HTU-R during loopback irrespective of status.		

1. This input is a Schmidt Triggered circuit and includes an internal pull-up device.
2. The period is 6 ms ±¹/₃₉₂ ms.
3. This input is a Schmidt Triggered circuit and includes an internal pull-down device.
4. I/O column entries: DI = Digital Input; DO = Digital Output; DI/O = Digital Input/Output; AI = Analog Input; AO = Analog Output; AI/O = Analog Input/Output; S = Supply.

SK70704/SK70706 784 kbps HDSL Data Pump Chip Set

Table 2: SK70706 HDX Pin Assignments/Signal Descriptions – continued

Group	Pin #	Symbol	I/O ⁴	Description
Hardware Interface (Hardware Control Mode) -cont'd	41	BELB	DI ¹	Back-End Loopback. In Active State a High forces an internal, transparent loopback with RDATA connected to TDATA and RFP connected to TFP.
	42	RCLKU	DO	Receive Baud Rate (392 kHz) Clock. Aligned with ICLK in HTU-R mode, phase synchronous with receive pulse stream, However, during Activating State, the clocks may not be aligned. In the HTU-C mode RCLKU has a constant, arbitrary, phase relationship with ICLK in Active State.
	43	TXTST	DI ¹	Transmit Test. Set high to enable isolated transmit pulse generation. The time between pulses is approximately 6 ms. TDATA controls the sign and TFP controls the magnitude of the transmitted quat pulses according to the 2B1Q encoding rules. In the HTU-R configuration, when the TXTST mode is selected, the Data Pump may begin activation.
Processor Interface (Software Control Mode)	36	D0	DI ¹ /O	Data bit 0. Eight-bit, parallel data bus.
	37	D1	DI ¹ /O	Data bit 1
	38	D2	DI ¹ /O	Data bit 2
	39	D3	DI ¹ /O	Data bit 3
	40	D4	DI ¹ /O	Data bit 4
	41	D5	DI ¹ /O	Data bit 5
	42	D6	DI ¹ /O	Data bit 6
	43	D7	DI ¹ /O	Data bit 7
	4	ADDR0	DI ³	Address bit 0. Four-bit address, selects read or write register.
	5	ADDR1	DI ³	Address bit 1
	6	ADDR2	DI ³	Address bit 2
	9	ADDR3	DI ³	Address bit 3
	18	RESET $\bar{2}$	DI ¹	Reset Pulse. Pull Low on power up to initialize circuits and stop all clocks.
	31	RESETI	DI ¹	Reset Pulse. Pull Low to initialize internal circuits. ICLK continues.
32	INT	DO	Interrupt Output. Open drain output. Requires an external 10 k Ω pull up resistor. Goes Low on interrupt.	
33	CHIPSEL	DI ³	Chip Select. Pull Low to read or write to registers.	
34	WRITE	DI ³	Write Pulse. Pull Low to write to registers.	
35	READ	DI ³	Read Pulse. Pull Low to read from registers.	
Misc.	29	n/c	–	No internal connection

1. This input is a Schmidt Triggered circuit and includes an internal pull-up device.

2. The period is 6 ms \pm $^{1/392}$ ms.

3. This input is a Schmidt Triggered circuit and includes an internal pull-down device.

4. I/O column entries: DI = Digital Input; DO = Digital Output; DI/O = Digital Input/Output; AI = Analog Input; AO = Analog Output; AI/O = Analog Input/Output; S = Supply.

Table 2: SK70706 HDX Pin Assignments/Signal Descriptions – continued

Group	Pin #	Symbol	I/O ⁴	Description
Clock and Control	14	CK6M	DI ³	6.272 or 12.544 MHz Reference Clock. Mandatory in HTU-R mode. Tie High or Low in HTU-C Mode. Clock input requires ± 32 ppm accuracy.
	15	CK6MEN	DO	CK6M Enable. Active High enable for CK6M clock. In HTU-R mode, this pin goes Low to indicate the PLL is tracking the input signal from the HTU-C. Not used in HTU-C.
	19	CK25M	DI	Receive Timing Clock (25.088 MHz). Tie to CK25M on ACC.
	20	DTR	DO	Serial Control Data Link. Transfers data at 12.544 Mbps. Tie to DTR on ACC.
	21	FS	DO	392 kHz Clock . Derived from CK25M. Tie to FS on ACC.
	22	AD0	DI	Analog to Digital Converter input pin. Tie to AD0 on ACC
	23	AD1	DI	Analog to Digital Converter input pin. Tie to AD1 on ACC
	24	AGCKIK	DI	AGC Adjust Signal. Controls analog gain circuit. Tie to AGCKIK on ACC.
	25	TCK3M	DO	Transmit Clock. Tie to TCK3M on ACC.
	26	TMAG	DO	Transmit Magnitude Bit. Tie to TMAG on ACC.
	27	TSGN	DO	Transmit Sign Bit. Tie to TSGN on ACC.

1. This input is a Schmidt Triggered circuit and includes an internal pull-up device.
 2. The period is $6 \text{ ms} \pm 1/392 \text{ ms}$.
 3. This input is a Schmidt Triggered circuit and includes an internal pull-down device.
 4. I/O column entries: DI = Digital Input; DO = Digital Output; DI/O = Digital Input/Output; AI = Analog Input; AO = Analog Output; AI/O = Analog Input/Output; S = Supply.

FUNCTIONAL DESCRIPTION

The HDSL Data Pump is a fully-integrated, two-chip solution (see block diagram on front page) which includes an SK70704 Analog Core Chip (ACC) and an SK70706 HDSL Digital Transceiver (HDX).

Transmit

The transmit data stream is supplied to the HDX at the TDATA input in a binary fashion. The HDX scrambles and 2B1Q encodes the data and adds the sync word and stuff quats based on the TFP frame pulse position. The injected stuff quats in a frame are equal to the last scrambled data symbol in that frame. The 2B1Q encoded transmit quat data stream (TSGN / TMAG) is then passed to the ACC which filters and drives it onto the line. For additional details on the transmit function, refer to Component Description.

Receive

The composite waveform of the receive signal plus trans-hybrid echo is filtered and converted to digital words at a rate of 392 k-words/second in the ACC. The ACC passes the digitized receive quat stream (AD0 and AD1) to the HDX. The HDX performs digital filtering, linear echo cancellation, frame recovery and descrambling. The HDX uses the transmit quat stream to generate the echo estimates and estimate error values. Using this error and the delayed transmit quat stream, the echo canceller coefficients are updated. The recovered, decoded and descrambled data is then output to the framer-mux from the HDX RDATA pin. For additional details on the receive function, refer to Component Description.

Control

The Data Pump offers two control modes - Hardware Mode and Software Mode. In Hardware mode the HDX receives control inputs via individually designated pins. In Software mode the HDX control data is supplied via an 8-bit parallel port. In either mode, communication between the HDX and the ACC is established via a unidirectional serial port (DTR).

Component Description

The following paragraphs describe the chip set components individually with reference to internal functions and the interfaces between Data Pump components.

Analog Core Chip (ACC)

The ACC incorporates the following analog functions:

- the transmit driver
- transmit and receive filters
- Phase-Locked Loop (PLL)
- hybrid circuitry analog-to-digital converter

The ACC provides the complete analog front end for the HDSL Data Pump. It performs transmit pulse shaping, line driving, receive A/D, and the VCO portion of the receiver PLL function. Transmit and receive controls are implemented through the serial port. The ACC line interface uses a single twisted pair line for both transmit and receive. Table 1 lists the ACC pin descriptions. Refer to Test Specifications for ACC electrical and timing specifications.

ACC Transmitter

The ACC performs the pulse shaping and driving functions. The ACC transmitter generates a 4-level output of $1/(8 * f(TCK3M))$ defined by TMAG and TSGN. Table 3 lists 2B1Q pulse coding parameters. Refer to Test Specifications for frequency and voltage templates.

ACC Receiver

The ACC receiver is a sophisticated sigma-delta converter. It sums the differential signal at RTIP/RRING minus the signal at BTIP/BRING. The first A/D signal comes out of AD0 at a bit stream rate of 12.544 MHz. The second stage of the A/D samples the noise of the first and generates the AD1 bit stream at 12.544 MHz.

Receiver gain is controlled by the HDX via the AGC2-0 bits in the DTR serial control stream. The AGCKIK output from the ACC is normally Low. It goes High when the signal level in the sigma delta A/D is approaching its clipping level, signaling the HDX to lower the gain.

The VCO is part of a phase-locked loop (PLL) locked to the receive data baud rate using an external phase detector. The VCO frequency is varied by pulling an external crystal with external varactor diodes that are controlled by the VPLL output. The VPLL output is, in turn, controlled by the serial port VCO and PLL bits.

Table 3: ACC Transmit Control

TSGN	TMAG	Output Symbol (quat)
1	0	+3
1	1	+1
0	1	-1
0	0	-3

HDSL Digital Transceiver (HDX)

The HDX incorporates the following digital functions:

- bit-rate transmit and receive signal-processing
- adaptive Echo-Cancelling (EC)
- adaptive decision feedback-equalization (DFE) using the receive quat stream and the internal error signal
- fixed and adaptive digital-filtering functions
- activation/start-up control and the microprocessor interface to the HDSL framer.

The HDX also provides the Data Pump Back-End interface for the customer defined/developed HDSL framer via serial data channels and clock signals. A simple, parallel 8-bit microprocessor interface on the HDX allows high-speed access to control, status and filter coefficient words. Table 2 lists the HDX pin descriptions. Refer to Test Specifications for HDX electrical and timing specifications.

The microprocessor interface on the HDX provides bit flags for signal presence, synchronization, activation completion, and loss of synchronization for a time greater than two seconds. Single-byte words representing receive signal level and the noise margin of the transceiver are also available on the microprocessor interface. One control byte allows the user to start the Data Pump activation sequence. The HDX controls the complete activation/

start-up sequence, allowing flexible, single-loop, fractional applications.

HDX/ACC Interface

The ACC provides the 25.088 MHz master clock, CK25M, to the HDX. The serial control stream framing signal FS is sampled inside the ACC with the CK25M rising edge. The serial control stream, DTR, is sampled inside the ACC by the rising edge of an internally-generated clock at $f(CK25M)/2$. This ACC internal clock has the same phase relationship with a similar clock inside the HDX, as established by the FS signal. In the HDX, the half-rate clock CK25M/2 and FS transition on the rising edge of CK25M, and DTR transitions coincide with the falling edge of CK25M/2. The output REFCLK in HTU-R Mode is equal to CK25M/2.

The A/D converter outputs, AD0 and AD1, are clocked out of the ACC with CK25M, having transitions coincidental with the rising edge of CK25M/2. The HDX samples AD0 and AD1 with the falling edge of its internal CK25M/2.

Transmit data, represented by TSGN and TMAG, is clocked from the HDX using the falling edge of TCK3M, the 3.136 MHz ($f(REFCLK)/4$) transmit time base clock. The ACC uses the rising edge of TCK3M to sample TSGN and TMAG. TSGN and TMAG change state at the baud rate, or every 8 cycles of TCK3M. Figure 3 shows relative timing for the HDX/ACC interface.

HDX/ACC Serial Port

The HDX continually writes to the ACC serial port. This serial stream consists of two 16-bit words as shown in Table 4. The data flows from the HDX to the ACC at a rate of $f(CK25M)/2$. Refer to the Test Specifications section for serial port timing relationships and electrical parameters.

Figure 3: HDX/ACC Interface – Relative Timing

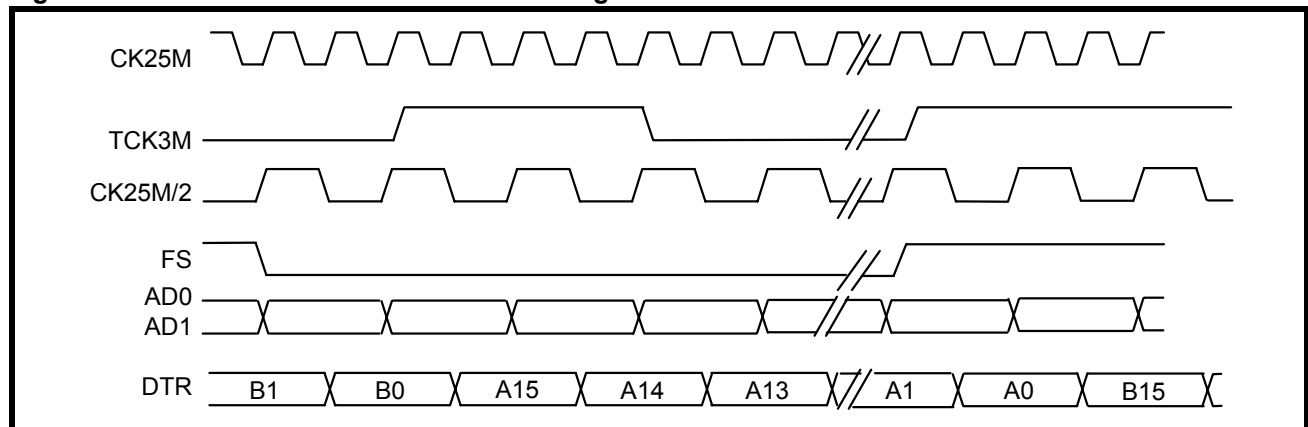

Line Interface

The Data Pump line interface consists of three differential pairs. The transmit outputs TTIP and TRING, receive inputs RTIP and RRING, and the balance inputs BTIP and BRING, all connect through a common transformer to a single twisted-pair line (see Figures 12 and 13). The transmit outputs require resistors in series with the transformer. A passive prefilter is required for the receive inputs. The balance inputs feed the transmit signals back to the Data Pump providing passive echo cancellation. Protection circuitry should be inserted between all Data Pump line interface pins and the transformer. Refer to the Applications section for typical schematics.

Table 4: HDX/ACC Serial Port Word Bit Definitions (See Figure 3)

Bit	Word A (on DTR)	Word B (on DTR)
15	INIT	COR4
14	<i>n/a</i>	COR3
13	<i>n/a</i>	COR2
12	TXOFF	COR1
11	TXDIS	COR0
10	TXTST	VCO2
9	AGC2	VCO1
8	AGC1	VCO0
7	AGC0	PLL7
6	FELB	PLL6
5	<i>n/a</i>	PLL5
4	PTR4	PLL4
3	PTR3	PLL3
2	PTR2	PLL2
1	PTR1	PLL1
0	PTR0	PLL0

HDSL Data Interface

The HDSL data interface includes the transmit and receive binary data streams, transmit and receive frame pulses, the 784 kHz clock (ICLK) and the receive frame and stuff quat indicator (RFST). Figure 4 shows relative timing for the framer interface. Refer to Test Specifications section for details on the Data Pump/framer interface. Figure 6 shows a complete HDSL system with both the remote HTU-R and central office HTU-C HDSL framer interfaces illustrated. Table 5 shows the TDATA requirements for the framer interface through the activation sequence. Once the ACTIVE 0-to-1 transition occurs, the Data Pump becomes transparent. Therefore, the HDSL framer must supply appropriate data to TDATA. Table 5 summarizes this requirement.

Table 5: HDSL Framer TDATA Requirements

Activation Process		TDATA	
Framer	Data Pump	Overhead	Data
Idle	Activating	<i>don't care</i>	<i>don't care</i>
Idle	Active 1	live	all 1s
Active-R	Active 1	live	all 1s
Active-T	Active 1	live	live
Link Active	Active 1	live	live
Link Active	Active 2	live	live

Figure 4: HDX/ACC Framer Interface – Relative Timing

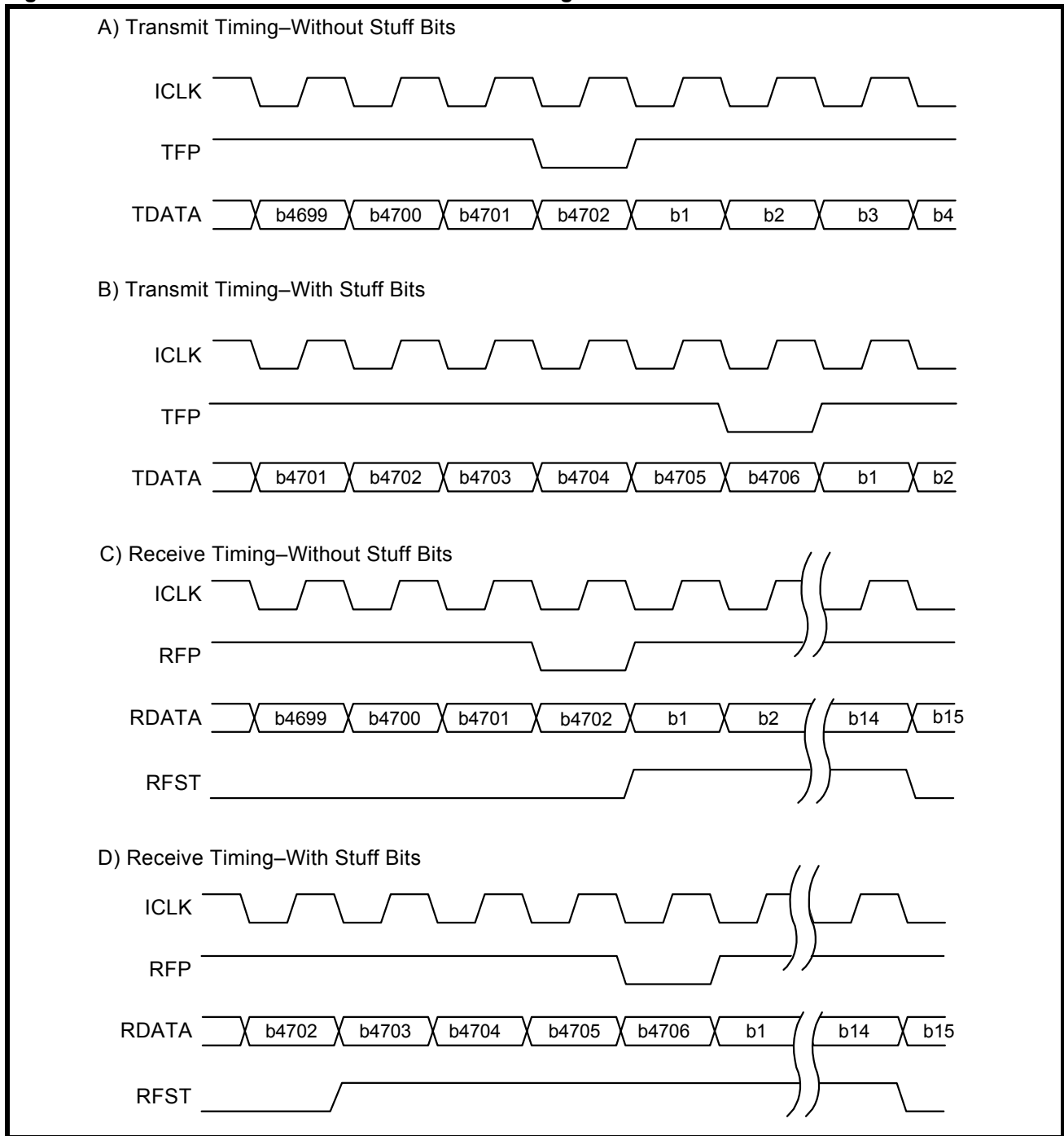

The HDSL framer interface is subject to the following rules:

1. When frame sync is not present (LOSW is High), all RDATA bits are set to 1.
2. If frame sync is lost on both Data Pump-R1 and Data Pump-R2, both units will fall back on the local reference frequency with ± 32 ppm tolerance, and stuff bits will be injected in their RDATA streams on every other frame. If frame sync is lost on either Data Pump-R1 or Data Pump-R2, that unit can be made to fall back on the REFCLK from the Data Pump-R which is still in frame sync, and stuff bits will be injected in the RDATA stream on every other frame of the out-of-frame Data Pump-R.
3. If frame sync is lost on either Data Pump-C1 or Data Pump-C2, both unit's receiver will fall back on the reference clock with ± 32 ppm or ± 5 ppm tolerance, and inject stuff bits in the RDATA stream on every other frame.
4. If either T1-R or T1-C loses sync or signal, it is assumed that the corresponding T1 receiver will fall back on a local reference with ± 32 ppm tolerance, and that transmit bit-stuffing control will still be applied through the TFP signal from the HDSL framer.
5. The HDSL framer should provide TFP signal with a period of $6\text{ ms} \pm 1/392\text{ ms}$ prior to an activation request for the HTU-C Data Pump(s). The framer should provide a valid TFP after power-up, before or immediately after LOS goes Low for the HTU-R Data Pump(s).
6. If for any reason the TFP signal from the HDSL framer is inactive (always High or unconnected), then the Data Pump will inject stuff bits in the TDATA stream in every other frame, although the Data Pump will not be synchronized to the HDSL framer. When a new TFP is provided the Data Pump will immediately reset the transmit frame alignment, typically causing loss of alignment at the other end.
7. A simultaneous **RESET2** to all HTU-C Data Pumps which use a common REFCLK eliminates phase shift between the ICLK outputs which may exist after power-up.

The ICLK outputs of all HTU-R Data Pumps may have an arbitrary phase difference even using a common CK6M reference.

Figure 5: Model for HDSL Data Pump and HDSL Framer Applications

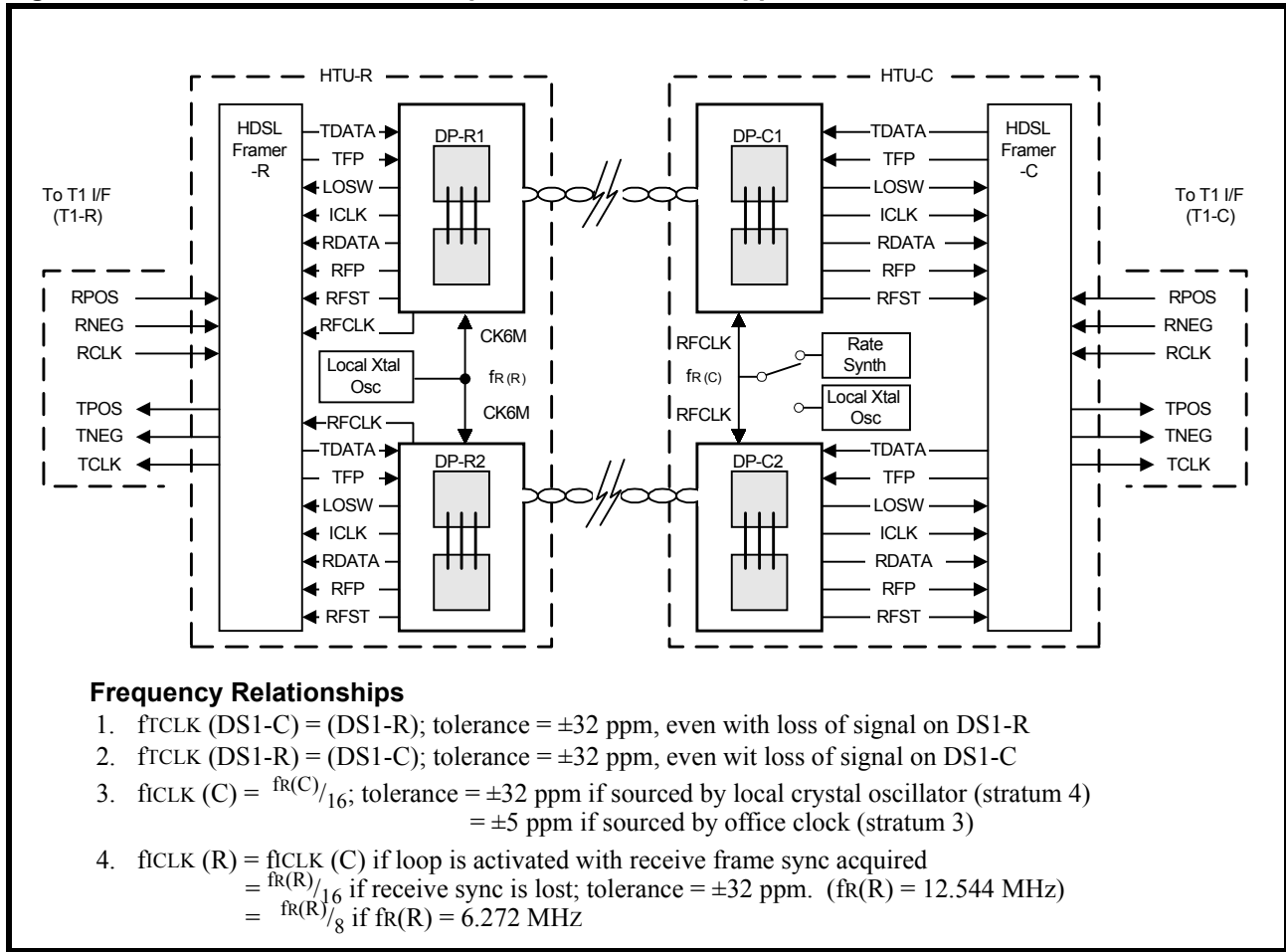

Microprocessor Interface (HDX)

Three primary control pins, $\overline{\text{CHIPSEL}}$ (Chip Select), $\overline{\text{READ}}$ and $\overline{\text{WRITE}}$, execute the Software Mode which also uses an interrupt output pin to report status changes. Four additional pins are used for the parallel bus addressing and eight pins for data I/O. Refer to Test Specifications for microprocessor interface timing in Software Mode.

Control Pins

Chip Select: The Chip Select ($\overline{\text{CHIPSEL}}$) pin requires an active Low signal to enable Data Pump read or write transfers over the data bus. To enable Hardware Mode hold this pin Low, along with $\overline{\text{READ}}$ and $\overline{\text{WRITE}}$.

Data Read: The Data Read pin ($\overline{\text{READ}}$) requires an active Low pulse to enable a read transfer on the data bus. When $\overline{\text{READ}}$ is pulled Low, the Data Pump data bus lines go from tristate to active and output the data from the register addressed by ADDR0-ADDR3. To avoid reading data during register updates, reads should be synchronized to the falling edge of FS. Alternatively, each read should be repeated until the same data is read twice within one baud time.

Data Write: The Data Write pin ($\overline{\text{WRITE}}$) requires an active Low pulse to enable a write transfer on the data bus. Data transfer is triggered by the rising edge of the $\overline{\text{WRITE}}$ pulse. To ensure data is written to the register addressed by ADDR0-ADDR3, valid data must be present on the HDX data bus lines before $\overline{\text{WRITE}}$ goes High.

Interrupt: The Interrupt pin ($\overline{\text{INT}}$) is an open drain output requiring an external pull-up resistor. The $\overline{\text{INT}}$ output is pulled active Low when an internal interrupt condition occurs. $\overline{\text{INT}}$ is latched and held until Main Status Register RD0 is read. An internal interruption results from a Low-to-High transition in any of four status indicators: ACTIVE, LOSW, LOSWT or TEXP. Any transition on LOS will also generate an interrupt. If an interrupt mask bit in register WR2 is set, any transition of the corresponding status bit will not trigger the $\overline{\text{INT}}$ output.

Register Access

Write

To write to an HDX register, proceed as follows:

1. Drive $\overline{\text{CHIPSEL}}$ Low.
2. Drive an address (0000, 0010, or 0011) onto ADDR0-ADDR3.
3. Observe address setup time.
4. Set 8-bit input data word on D0-D7.
5. Pull $\overline{\text{WRITE}}$ Low, observing minimum pulse width.
6. Pull $\overline{\text{WRITE}}$ High, observing hold time for data and address lines.

Read

Procedures for reading the HDX registers vary according to which register is being read. Accessing registers RD0, RD1, RD2, RD5 and RD6 is relatively simple. Reading registers RD3 and RD4 is more complex. *Unless parallel port reads are synchronized with the falling edge of FS, all read operations should be repeated until the same data is read twice within one baud time.*

To read register RD0, RD1, RD2, RD5 or RD6 proceed as follows:

1. Drive $\overline{\text{CHIPSEL}}$ Low.
2. Pull $\overline{\text{READ}}$ Low, observing minimum pulse width.
3. Pull $\overline{\text{READ}}$ High to complete the read cycle.

Registers RD3 and RD4 hold the coefficient values from the DFE, EC, FFE and AGC as shown in Table 9. Register RD3 holds the lower byte value and register RD4 holds the upper byte value. To reconstruct the complete 16-bit word, concatenate the least significant and most significant bytes.

To read registers RD3 and RD4 proceed as follows:

1. Select the desired coefficient by writing the appropriate code from Table 9 to register WR3.
2. Enable the Coefficient Read Register by writing a 1 to bit b0 (CRD1) in register WR2.
3. Perform standard register read procedure listed in steps 1 through 6 above to read the lower byte from RD3 and the upper byte from RD4.
4. Concatenate the RD3 and RD4 to obtain the complete 16-bit word.

Registers

Three write registers and seven read registers are available to the user. Table 6 lists these registers and the following paragraphs describe them in more detail.

Some of the registers contain *reserved* bits. Software must deal correctly with reserved fields. For reads, software

must use appropriate masks to extract the defined bits and not rely on reserved bits being any particular value. In some cases, software must program reserved bit positions to a particular value. This value is defined in the individual bit descriptions.

After asserting the **RESET1** or **RESET2** signal, the Data Pump initializes its registers to the default value.

Table 6: Register Summary

ADDR	Write Registers			Read Registers		
	A3-A0	WR#	Name	Table	RD#	Name
0000	WR0	Main Control	7	RD0	Main Status	10
0001		<i>reserved</i>	<i>n/a</i>	RD1	Receiver Gain Word	11
0010	WR2	Interrupt Mask	8	RD2	Noise Margin	12
0011	WR3	Read Coefficient Select	9	RD3	Coefficient Read Register (lower byte)	13
0100		<i>reserved</i>		RD4	Coefficient Read Register (upper byte)	13
0101		<i>reserved</i>		RD5	Activation Status	14
0110		<i>reserved</i>		RD6	Receiver AGC and FFE Step Gain	15
0111-1001		<i>reserved</i>			<i>reserved</i>	

WR0—Main Control Register

Address: A3-0 = 0000

Default 00h

Attributes: Write Only

Control Register bits serve the same purpose in Software Mode as the like-named individual pins in Hardware Mode. Table 7 lists bit assignments for the WR0 register.

Table 7: Main Control Register WR0

Bit	Description
b7	Transmit Test Pattern Enable (TXTST). Set TXTST to 1 to enable isolated transmit pulse generation. The time between pulses is 6 ms. TDATA controls the sign and TFP controls the magnitude of the transmitted symbols according to the 2B1Q encoding rules. In the HTU-R configuration when the TXTST mode is selected, the Data Pump may begin activation.
b6	Back-End Loop Back (BELB). In the Active State, set BELB to 1 to enable an internal, transparent loopback of the HDX RDATA to TDATA and RFP to TFP.
b5	Front End Loop Back (FELB). In the HTU-C mode with the Data Pump in the Inactive State, set FELB to 1 to enable an ACC front-end loopback. The Data Pump will begin activation and transmission on the line, but will ignore any signal from the HTU-R instead synchronizing to its own transmit signal.
b4	Repeater Mode (RPTR). The RPTR bit is set to 1 and the HTU-C pin is pulled High to program the Data Pump for operation on the side of the HDSL repeater driving the remote HTU-R. RPTR is set to 0 and the HTU-C pin is tied Low to program the Data Pump for operation on the side of the repeater driven by the central office HTU-C.
b3	Loop Control (LOOPID). For 2-pair ANSI HDSL applications, LOOPID defines the frame sync word format to encode the loop number in HTU-C mode. Set LOOPID to 0 for Loop1 or to 1 for Loop2. The Data Pump transmits a 7-quat, time-reversed, double-Barker code on Loop2. For 3-pair ETSI HDSL applications, LOOPID should be set to 0 on all loops because the loop number is encoded in the HDSL overhead using the Z bits.
b2	Insertion Loss Measurement Test (ILMT). Set ILMT to 1 to enable transmission of a scrambled all ones insertion loss measurement test pattern. In the HTU-R configuration when the ILMT mode is selected, the Data Pump may begin activation.
b1	Quiet Mode (QUIET). Set QUIET to 1 to force the Data Pump into the De-Activated State with the transmitter silent. Setting QUIET to 0 will not cause the Data Pump to reactivate. In the HTU-R mode, the Data Pump will not respond to an S0 signal from the HTU-C when QUIET is set to 1, but may activate after QUIET is set to 0 even if the HTU-C transmission has already ceased.
b0	Activation Request (ACTREQ). In the HTU-C mode when the Data Pump is in the Inactive State and Quiet is set to 0, setting the ACTREQ bit to 1 will initiate an activation sequence. Because ACTREQ is a level- rather than an edge-triggered signal, it should be reset to 0 again within approximately 25 seconds to prevent the immediate start of another activation cycle if the current activation attempt fails. If an activation attempt fails, the processor should allow the Data Pump to remain in the Inactive State where the transmitter is silent for 32 seconds before generating another activation request to allow the HTU-R to return to the Inactive State. It is possible to shorten this quiet period following a failed activation by implementing additional algorithms described in the section entitled “Activation State Machines.”

WR2—Interrupt Mask Register

Address: A3-0 = 0010
 Default: 00h
 Attributes: Write Only

Table 8 shows the various interrupt masks provided in register WR2.

Table 8: Interrupt Mask Register WR2

Bit	Description
b7:6	<i>Reserved. Must be set to 0.</i>
b5	LOSMSK. 1=Masked. 0=Not Masked. Interrupt mask for the LOS condition
b4	LSWTMSK. 1=Masked. 0=Not Masked. Interrupt mask for the LOSWT condition
b3	LSWMSK. 1=Masked. 0=Not Masked. Interrupt mask for the LOSW condition
b2	ACTMSK. 1=Masked. 0=Not Masked. Interrupt mask for the TEXP condition and the ACTIVE condition
b1	<i>Reserved. Must be set to 0.</i>
b0	Enable coefficient read register (CRD1). 1=Enable. 0=Disable. Used in conjunction with WR3 for reading coefficient values.

WR3—Read Coefficient Select Register

Address: A3-0 = 0011
 Default: 00h
 Attributes: Write Only

Table 9 lists the bit maps used to select the coefficient read from the HDX.

Table 9: Read Coefficient Select Register WR3

Hex Value	Selected Registers	Description
00-07	DFE1-DFE8	DFE coefficients
08-0F	EC1-EC8	Echo Cancellation
10-15	FFE1-FFE6	FFE coefficients 1-6
16-19	<i>reserved</i>	
1A	AGC Tap	AGC Tap
1B-FF	<i>reserved</i>	

RD0—Main Status Register

Address: A3-0 = 0000

Default: xxh (x=undefined)

Attributes: Read Only

Status Register bits serve the same purpose in Software Mode as the like-named individual pins in Hardware mode. Table 10 lists the bit assignments in this register.

Table 10: Main Status Register RD0

Bit	Active Description
b7	Timer Expiry (TEXP). Set to 1 to indicate 30-second timer expiration in the Active State. <ul style="list-style-type: none"> Causes interrupt on changing from 0 to 1; masked by ACTMSK = 1. Latched event; reset on read, with persistence while in the Active State.
b6	TIP/RING polarity reversed (INVERT). 0 = polarity reversal. Valid only in Active State.
b5	Change Of Frame Alignment (COFA). Indicates that re-acquisition of frame sync is in a different position with respect to the last frame position. Does not cause interrupt. Latched event; reset on read
b4	Loss Of Signal for HTU-R (LOS). 1 = loss of line signal energy on entering Inactive State.
	Loss of Signal Timer Expiration for HTU-C (LOST). 1 = loss of signal for 1 second on entering Inactive State. <ul style="list-style-type: none"> Causes interrupt on transitions from 0 to 1 or 1 to 0 that are masked by LOSMSK = 1. LOS/LOST is not a latched event.
b3	Loop Number Control (LOOPID). 0 = loop 1; 1 = loop 2. Valid only in Active States, 0 in all others <i>Note: This bit is used only for ANSI systems. The ETSI recommendation defines overhead bits for loop identification.</i>
b2	Loss of Sync Word Timer Expiry (LOSWT). Indicates two seconds of LOSW. <ul style="list-style-type: none"> Causes interrupt on changing from 0 to 1; masked when LSWTMSK = 1. Latched event; reset on read; with persistence while in the Deactivated State.
b1	Loss of Sync Word (LOSW). <ul style="list-style-type: none"> Causes interrupt on changing from 0 to 1; masked by LSWMSK = 1. Latched event; reset on read; with persistence while in the Pending Deactivation State.
b0	Active State (ACTIVE). 1 = Completion of layer 1 activation. <ul style="list-style-type: none"> Causes interrupt on changing from 0 to 1; masked by ACTMSK = 1. Latched event; reset on read with persistence if still in the Active State.

RD1—Receiver Gain Word Register

Address: A3-0 = 0001

Default: xxh (x=undefined)

Attributes: Read Only

The 8-bit word in this register is the eight most significant bits of the main FFE AGC tap, which, along with the AGC and DAGC values (RD6), represent the receiver gain required to compensate for line loss, and to normalize the receive 2B1Q pulses to a fixed threshold. Bit b7 (sign bit, always 0) is the MSB with bit b0 the LSB. The AGC tap value is determined as follows:

$$\text{AGC Tap} = \sum_{i=0}^6 b_i * 2^{i-6}$$

Table 11: Receiver Gain Word Register

Bit	Description
b7-b0	FFE AGC Tap Value (eight most significant bits).

RD2—Noise Margin Register

Address: A3-0 = 0010
 Default: xxh (x=undefined)
 Attributes: Read Only

The noise margin of the received signal is an input to the HDSL framer’s Activation State Machine. The noise margin must reach a threshold level before the HDSL framer can transition to the fully Active State. The HDX provides a calculated, logarithmic noise margin value used by the HDSL framer. This eight-bit word, stored in register RD2, is available every baud, although updated only every 64 baud. Table 12 shows the noise margin coding. To calculate the SNR, use this equation:

$$\text{SNR} = \text{Noise Margin} + 21.5 \text{ dB}$$

Error propagation in the DFE and de-scrambler may introduce some fractional errors in this formula, however, the relationship between the SNR and the noise margin remains valid as long as the noise follows a Gaussian distribution.

Since the average period of the calculation is very short (64 baud = 163 μs), the recommended procedure for evaluating transmission quality is to average at least 1000 samples over a 163 ms period.

Table 12: Noise Margin Register RD2 (Noise Margin Coding)

MSB				LSB				Noise Margin ¹
b7	b6	b5	b4	b3	b2	b1	b0	
0	0	1	1	0	1	0	1	+26.5
0	0	1	0	1	1	1	1	+23.5
0	0	1	0	1	0	1	1	+21.5
0	0	1	0	1	0	0	1	+20.5
0	0	1	0	0	1	1	1	+19.5
0	0	1	0	0	1	0	1	+18.5
0	0	1	0	0	1	0	0	+18.0
0	0	1	0	0	0	1	0	+17.0
0	0	1	0	0	0	0	0	+16.0
0	0	0	1	1	1	1	0	+15.0
0	0	0	1	1	1	0	0	+14.0
0	0	0	1	1	0	1	0	+13.0
0	0	0	1	1	0	0	0	+12.0
0	0	0	1	0	1	1	0	+11.0
0	0	0	1	0	1	0	0	+10.0
0	0	0	1	0	0	1	0	+9.0
0	0	0	1	0	0	0	0	+8.0
0	0	0	0	1	1	1	0	+7.0
0	0	0	0	1	1	0	0	+6.0
0	0	0	0	1	0	1	0	+5.0
0	0	0	0	1	0	0	0	+4.0
0	0	0	0	0	1	1	0	+3.0
0	0	0	0	0	1	0	0	+2.0
0	0	0	0	0	0	1	0	+1.0
0	0	0	0	0	0	0	0	0.0
1	1	1	1	1	1	1	0	-1.0
1	1	1	1	1	1	0	0	-2.0
1	1	1	1	1	0	1	0	-3.0
1	1	1	1	1	0	0	0	-4.0
1	1	1	1	0	1	1	0	-5.0
1	1	1	1	0	1	0	0	-6.0

1. Accuracy of noise margin is ±1 dB.

RD3 (LSB), RD4 (MSB)—Coefficient Read Register

Address: RD3 (A3-0 = 0011)
RD4 (A3-0 = 0100)

Default: xxh (x=undefined)

Attributes: Read Only

Coefficient Read Word (read from the HDX) comes from the location configured in the Read Coefficient Select Register (WR3, Address A3-0 = 0011). The HDX updates this word on the rising edge of the receive clock, FS. Read register RD3 is the lower byte, and RD4 is the upper byte.

Table 13: Coefficient Read Register

Bit	Description
b7-b0	Coefficient Word Value. RD3 contains the lower byte; RD4 the upper byte.

RD5—Activation Status Register

Address: A3-0 = 0101

Default: xxh (x=undefined)

Attributes: Read Only

The ACT bits indicate the current state of the HDX transceiver during the Activating State as listed in Table 14. (For any state other than the Activating State, the ACT bits will be “0000”.)

Table 14: Activation Status Register RD5

ACT Bits 3-0	State in HTU-C Mode	State in HTU-R Mode
0000	Inactive	Inactive
0001	Pre-AGC	Wait
0010	Pre-EC	AAGC
0011	SIGDET	EC
0100	AAGC	PLL1
0101	EC	PLL2
0110	PLL	4LVLDDET
0111	4LVLDDET	FRMDET
1000	FRMDET	–

RD6—Receive Step Gain Register

Address: A3-0 = 0110

Default: xxh (x=undefined)

Attributes: Read Only

This 8-bit register represents AGC and FFE gain coefficients (GAGC and GFFE, respectively). Bit assignments are listed in Table 15. The approximate line loss (LL) can be determined using these values in the following equation:

$$LL = 20\log_{10} (GFFE * AGC \text{ tap}) + GAGC + 28 \text{ dB}$$

GFFE corresponds to DAGC in the HDX and GAGC is from the ACC. Bits ST0-ST2 indicate the Data Pump activation states as shown in Figures 6 and 8 and Table 16.

Table 15: Receiver AGC and FFE Step Gain Register RD6

Bit	Description																		
b7	ST2. Data Pump Activation State–bit 2																		
b6	ST1. Data Pump Activation State–bit 1																		
b5-b4	GFFE1, GFFE0. Digital Gain Word–bit 1 and Digital Gain Word–bit 0. <table border="0" style="margin-left: 20px;"> <tr> <td>Bits <5:4></td> <td>GFFE Value</td> </tr> <tr> <td>00</td> <td>2⁰ = 1</td> </tr> <tr> <td>01</td> <td>2¹ = 2</td> </tr> <tr> <td>10</td> <td>2² = 4</td> </tr> <tr> <td>11</td> <td>2³ = 8</td> </tr> </table>	Bits <5:4>	GFFE Value	00	2 ⁰ = 1	01	2 ¹ = 2	10	2 ² = 4	11	2 ³ = 8								
Bits <5:4>	GFFE Value																		
00	2 ⁰ = 1																		
01	2 ¹ = 2																		
10	2 ² = 4																		
11	2 ³ = 8																		
b3	ST0. Data Pump Activation State–bit 0																		
b2-b0	GAGC2-GAGC0. Analog Gain Word–bit 2,1 and 0. <table border="0" style="margin-left: 20px;"> <tr> <td>Bits <2:0></td> <td>GAGC Value (dB)</td> </tr> <tr> <td>000</td> <td>-12</td> </tr> <tr> <td>001</td> <td>-10</td> </tr> <tr> <td>010</td> <td>-8</td> </tr> <tr> <td>011</td> <td>-6</td> </tr> <tr> <td>100</td> <td>-4</td> </tr> <tr> <td>101</td> <td>-2</td> </tr> <tr> <td>110</td> <td>0</td> </tr> <tr> <td>111</td> <td>+2</td> </tr> </table>	Bits <2:0>	GAGC Value (dB)	000	-12	001	-10	010	-8	011	-6	100	-4	101	-2	110	0	111	+2
Bits <2:0>	GAGC Value (dB)																		
000	-12																		
001	-10																		
010	-8																		
011	-6																		
100	-4																		
101	-2																		
110	0																		
111	+2																		

Activation State Machines

The Data Pump Activation/Start-Up circuitry is compatible with ANSI T1E1.4/94-006. Full HTU-C activation is partitioned between the Data Pump and the framer. Figure 6 represents the HTU-C Data Pump Activation State Machine, and Figure 7 shows the HTU-C framer activation state machine. Figures 8 and 9 present the corresponding HTU-R state machines. Table 16 lays out the correspondence between the Data Pump and Framer state machines. In Software Mode, the ST_n bits in Read Register 6 (ADDR 0110) show the current status of the state machine.

HTU-C Data Pump Activation

When the HTU-C Data Pump is powered up and reset is applied, the chip is in the Inactive State as shown at the top of Figure 6. Starting at the Inactive State, the device progresses in a clockwise direction through the Activating, Active-1, Active-2, Pending De-Activation and De-Activated States.

In the hardware mode when the Data Pump is in the Inactive State and the QUIET pin is Low, a Low-to-High transition on the ACTREQ pin initiates activation of the link. In the software mode when the Data Pump is in the Inactive State and the QUIET bit is set to 0, setting the ACTREQ bit to 1 initiates activation of the link. Because the ACTREQ control bit is level sensing, it should be set to 1 and then reset to 0 again within 25 seconds to generate a single activation request.

During the Activating State, the echo canceller, equalizer and timing recovery circuits are all adapting during the simultaneous transmission and reception of the framed, scrambled-ones data transmitted as a two-level code (S0) or as the four-level code (S1). If the receive frame sync word is not detected in two consecutive frames within 30 seconds, the timer expires and the device moves to the De-Activated State and ceases transmission. It will then immediately transition to the Inactive State (setting LOST regardless of whether HTU-R transmission has ceased). Another activation request should not be generated for 32 seconds allowing the HTU-R to timeout, detect LOS and move from the De-Activated to the Inactive State. In microprocessor-based systems, this time may be shortened by implementing a processor routine to reset the HTU-R Data Pumps which are in the Activating State when no HTU-C signal is present.

Successful detection of the sync word drives the State machine to the Active-1 State. This is indicated by a 0-to-1 transition of the ACTIVE bit (Software Mode). If the

HTU-C Data Pump remains locked to the sync word until the Activation Timer expires, the device transitions to the Active-2 (fully active) State. If sync is lost, as indicated by a 0-to-1 transition on LOSW, the HTU-C Data Pump transitions to the Pending De-Activation State.

In Pending De-Activation, the HTU-C Data Pump progresses to the De-Activated and Inactive States with the expiration of the respective timers. If the sync word is detected before the LOSW timer expires, the HTU-C Data Pump returns to either Active 1 or Active-2. (The HTU-C Data Pump returns to whichever state it occupied before transitioning to Pending De-Activation.)

The HTU-C Data Pump will exit the Active-2 State in one of two ways. A Low-to-High transition on the QUIET pin (Hardware Mode) or the QUIET bit (Software Mode), forces the HTU-C Data Pump directly to the De-Activated State. The only other means of exiting the Active State is through a loss of receive sync word (LOSW). LOSW is set when six consecutive frames occur without a sync word match. The LOSW event puts the HTU-C Data Pump into the Pending De-Activation State.

The HTU-C Data Pump remains in the Pending De-Activation State for a maximum of two seconds. If a sync word is detected within two seconds after the LOSW event, the HTU-C Data Pump reenters the Active State. If the LOSW condition exceeds two seconds, an LOSWT event occurs which sends the chip to the De-Activated State. When the De-Activated State is reached from Pending De-Activation, the HTU-C Data Pump returns to the Inactive State and declares LOST when it detects no signal from the HTU-R for one second. The Data Pump should remain in the Inactive State for 15 seconds before another activation attempt.

Table 16: Data Pump/Framer Activation State Machine Correspondences

ST2	ST1	ST0	Data Pump State	Framer State
0	0	0	Inactive	Idle
0	0	1	Activating – 30 s timer running	Idle
0	1	0	Active – 30 s timer running (Active-1) ¹	Idle, Active-R or Active-T, or Link Active
0	1	1	Active – 30 s timer expired (Active-2) ¹	Link Active
1	0	0	Pending De-Activation ¹	Link Active or Active-R or Active-T
1	0	1	De-Activated	Idle
1	1	0	<i>unused</i>	<i>unused</i>
1	1	1	<i>unused</i>	<i>unused</i>

1. The data pump samples the TDATA input for all transmit data except the 14 sync bits at the start of each frame during states 010, 011 and 100.

HTU-C Framer Activation

Figure 7 shows the activation state machine for the HTU-C HDSL framer. Transition to the Link Active stage from the Idle stage (upper left) requires successful exchange of a pair of indicator bits, **indc** and **indr**. (“INDC” and “INDR” are internal status signals within the HDSL framer; “**indc**” and “**indr**” are bits in the overhead channel.) The HTU-C device transmits the **indc** bit, and the HTU-R device transmits the **indr** bit. The overhead frame carries these indicator bits during transmission of the S1 training pattern.

Figure 7 illustrates the two partially active states (Active-R and Active-T) which may serve as transitions between the Idle and Link Active States. If the HTU-C device reaches the SNR threshold, its framer sets the INDC bit and the device transitions to the Active-R State. If the HTU-R device reaches the SNR threshold, it will transmit the **indr** bit to the HTU-C. The HTU-C will then transition to the Active-T State. From either of the partially Active States, the devices transition to the full Link Active State only with both Indication bits set.

Upon entering the Active States (Active-R, Active-T or Link Active), the chip will open up the full duplex communication link with the HTU-R. Only the Active and Pending De-Activation States allow full payload transmission. In all states except Active-1 and Active-2, the RDATA output is clamped High.

Figure 6: HTU-C Data Pump Activation State Machine

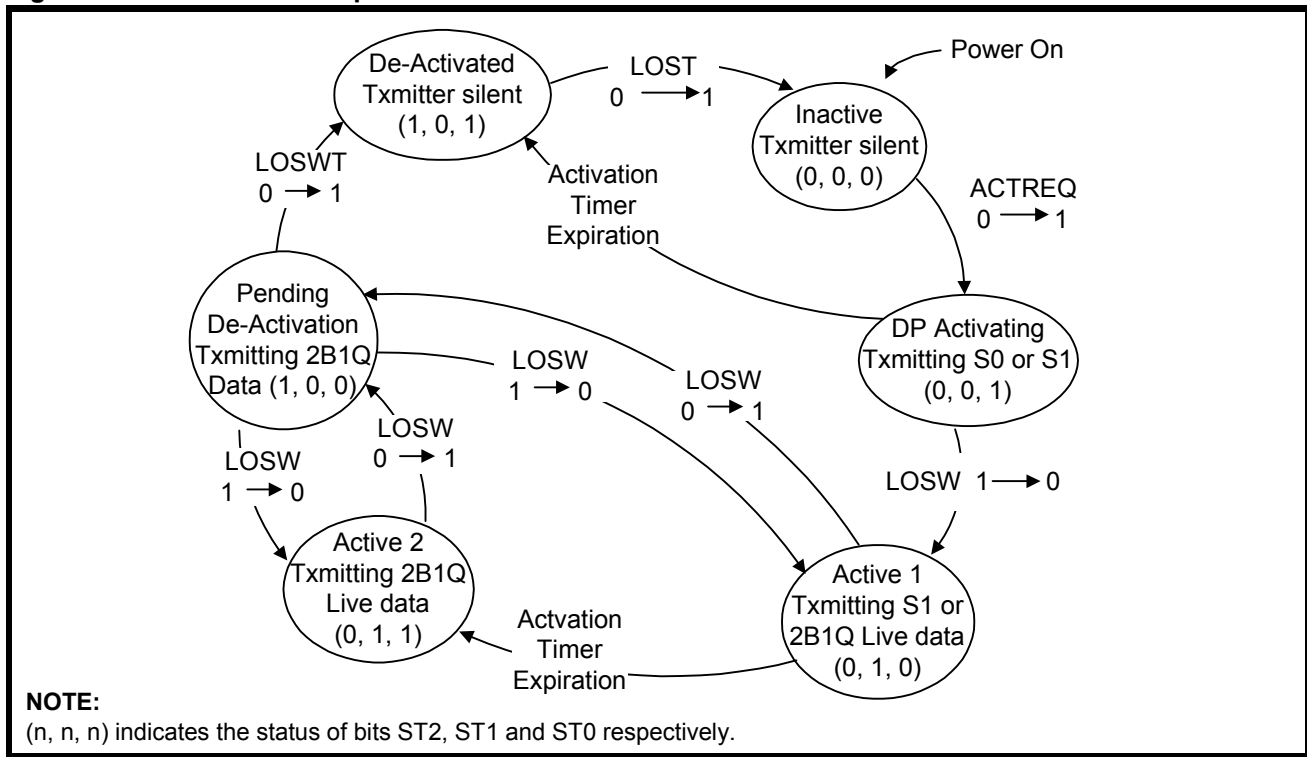
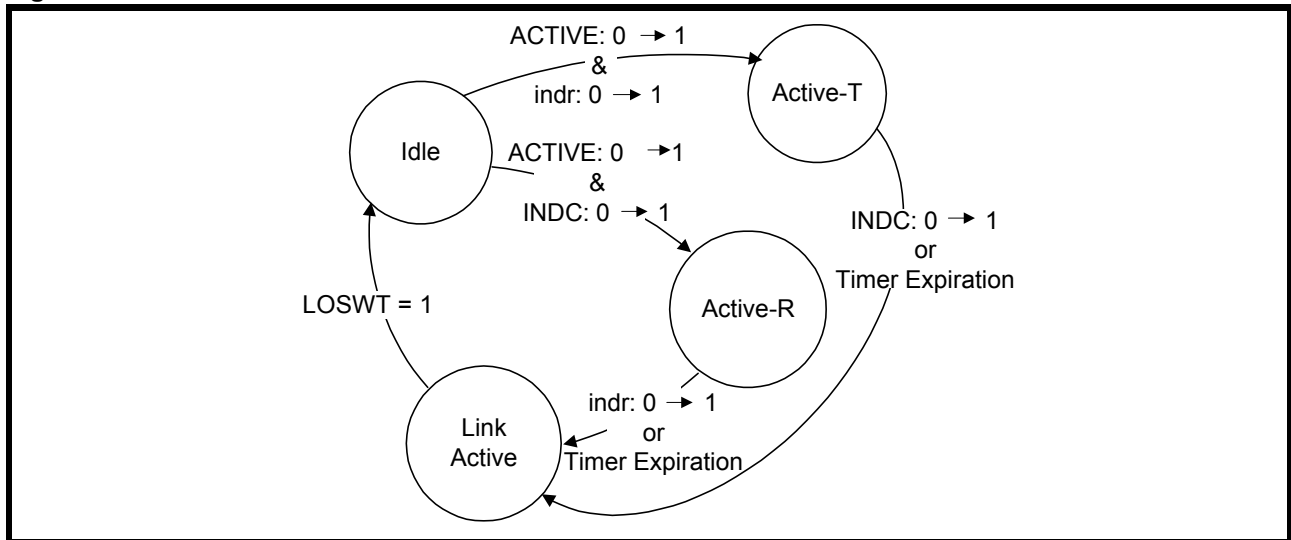

Figure 7: HTU-C HDSL Framer Activation State Machine



HTU-R Data Pump Activation

Figures 8 and 9 represent the HTU-R Data Pump Activation State Machine and the HTU-R HDSL Framer State Machine. The activation state machines for HTU-R and HTU-C devices are similar. Both Data Pump machines start at the Inactive State and progress clockwise through the Activating, Active-1, Active-2, Pending De-Activation, and De-Activated States. One difference between them is in the initial condition required to exit from the Inactive State. The HTU-C Data Pump responds to the Activation Request (ACTREQ) signal. The HTU-R device responds only to the presence of signal energy on the link. Thus, only an active HTU-C device can bring up the link. Once the HTU-C begins transmitting, the HTU-R device will automatically activate and attempt synchronization.

The other difference between the Data Pump state machines is the impetus for the change from the De-Activated to the Inactive State. In the HTU-C Data Pump, expiration of a one-second loss of signal timer (LOST) causes the transition. In the HTU-R the transition occurs immediately on Loss of Signal (LOS).

HTU-R Framer Activation

The HDSL framer activation state machines for HTU-C and HTU-R are also similar. The difference is in the indicator bits which cause the transition to either the Active-T or Active-R State. On the HTU-R side, the **indr** bit causes the transition to the Active-R State, and the **indc** bit causes the transition to the Active-T State. From either partially active state, receipt of the remaining indicator bit or timer expiry causes the transition to the full Link Active State.

HDSL Synchronization State Machine

Figure 10 shows the HDSL Synchronization State Machine incorporated in the HDX. It applies to both HTU-C and HTU-R devices. Table 17 lists the correspondence between the Synchronization states and Activation states. The Sync state machine is clocked by the receive signal framing. Starting at the initial Out-of-Sync condition (State 0), the device progresses in a clockwise direction through State 1 until Sync is declared in State 2. Two consecutive frame sync word matches are required to achieve synchronization.

Once the In-Sync condition is declared, six consecutive frame sync mismatches will cause the device to transition through States 3 through 7 and declare an Out-of-Sync condition in State 8. From State 8, the device will return either to State 2 or to State 0. If the 2-second timer expires without reestablishing frame sync (LOSWT = 1) or if the receive signal is lost entirely (LOS = 1), the device returns directly to State 0.

If frame sync is reestablished, the device will return to the In-Sync condition (State 2) through State 9 if two consecutive frames are received without any change of frame alignment (COFA = 0). If a change of frame alignment does occur (COFA = 1), two consecutive matches are required to transition through State 10 back to State 2.

Table 17: Activation – Synchronization

Activation State	Synchronization States
Inactive	State 0
Activating	State 1
Active	States 2, 3, 4, 5, 6, and 7
Pending De-Activation	States 8, 9, and 10

Figure 8: HTU-R Data Pump Activation State Machine

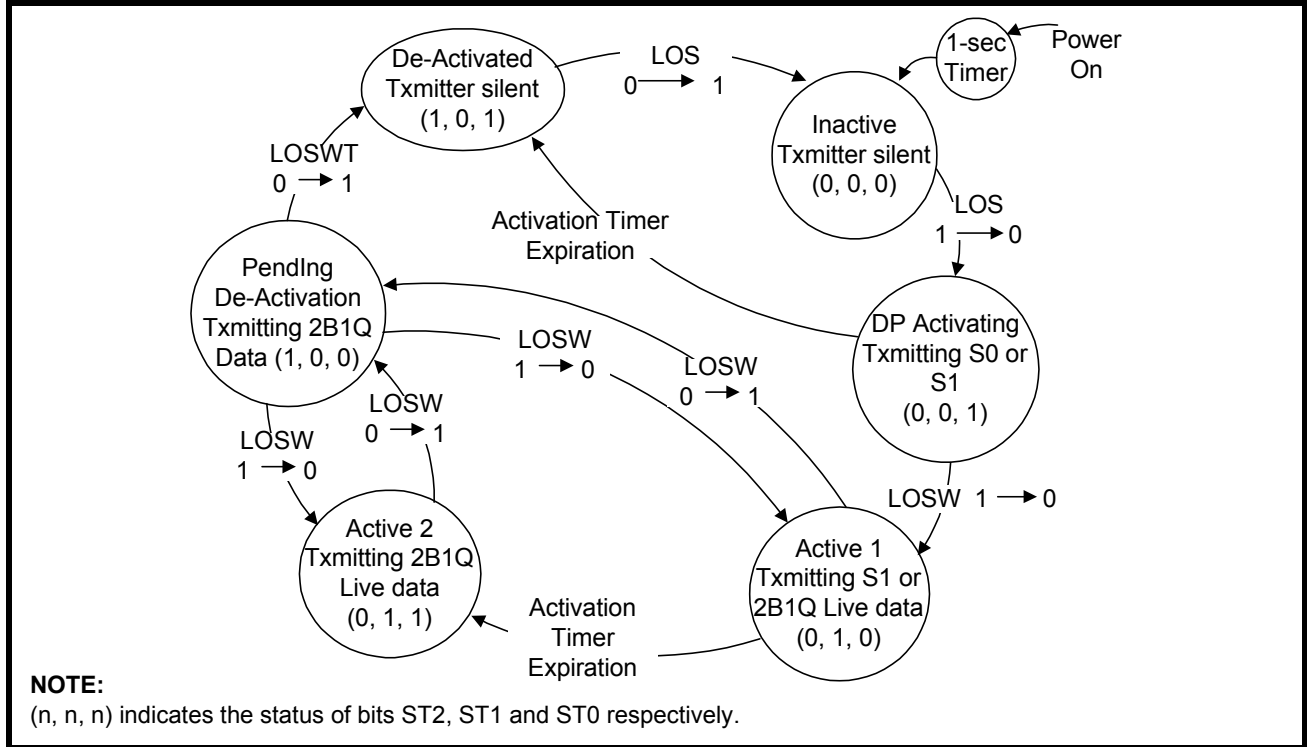

Figure 9: HTU-R HDSL Framer Activation State Machine

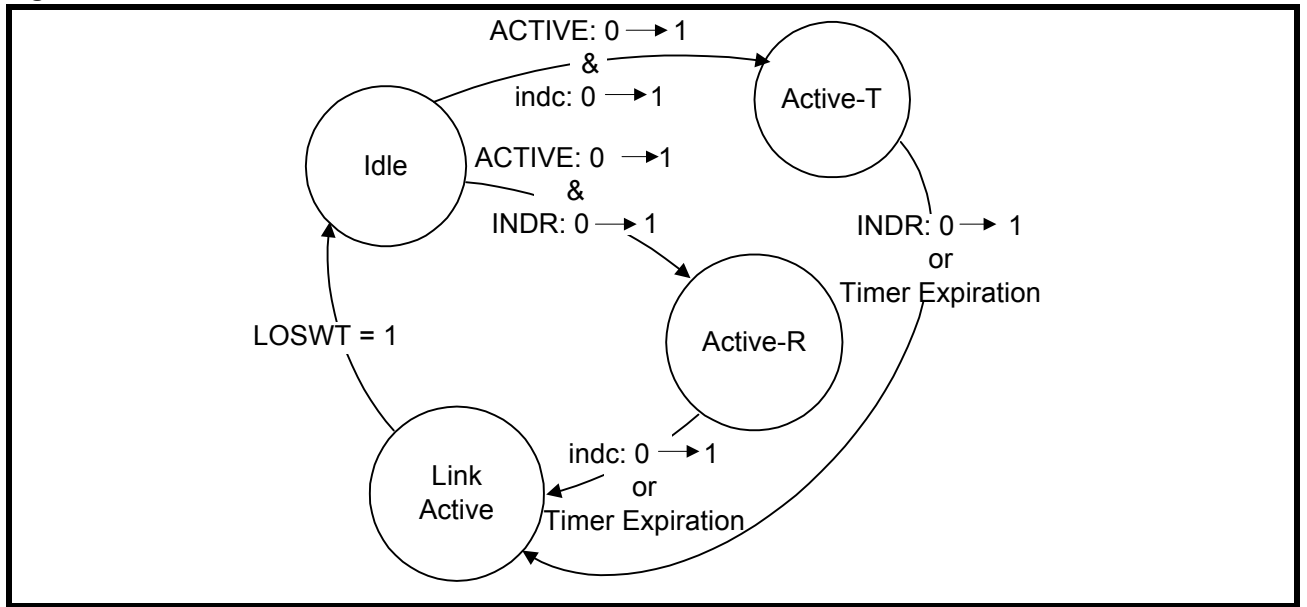
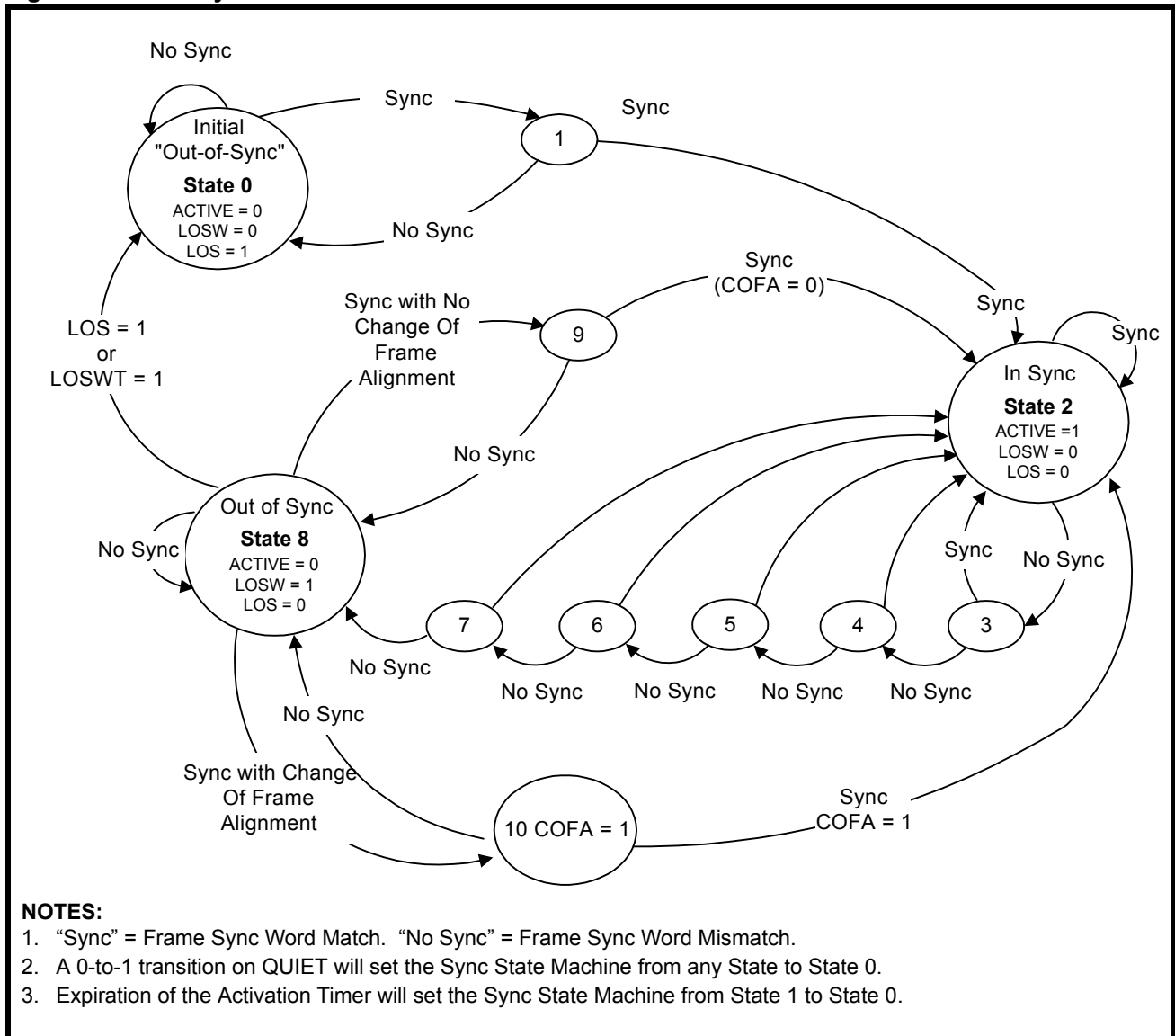

Figure 10: HDSL Synchronization State Machine



APPLICATION INFORMATION

HDSL Framer State Machine Design

Because of data transparency characteristics of the Data Pump, two issues impact on implementing the HDSL Framer Activation State machines for both HTU-C and HTU-R devices:

1. Once the ACTIVE 0-to-1 transition occurs, the Data Pump becomes transparent. Therefore, the HDSL framer must put appropriate data in TDATA. Table 5 summarizes this requirement.
2. The link indicator bits (**indc** and **indr**) must stabilize before the device makes the transition from the Idle to the Active-T State. Thus, the HDSL framer design may detect 6 consecutive matches for the indication bit transition. This is particularly important for non-CSA loops where a lower SNR may be experienced.

PCB Layout

The following are general considerations for PCB layout using the HDSL Data Pump chip set:

- Refer to Figures 12 and 13, and Table 18. Keep all shaded components close to the pins they connect to.
- Use a four-layer or more PCB layout, with embedded power and ground planes.
- Break up the power and ground planes into the following regions. Tie these regions together at the common point where power connects to the circuit:
 - Digital Region
 - Analog Region
 - VCXO subregion
 - ACC, Line I/F, and IBIAS subregion
- Use larger feedthroughs (“vias”) and tracks for connecting the power and ground planes to the power and ground pins of the ICs than for signal connections. Place the decoupling capacitors right at the feedthrough power/ground plane ties, or on the tracks to the IC power/ground pins as close to the pins as possible.
- On the User Interface Connector, route digital signals to avoid proximity to the TIP, RING, and CT lines.
- Provide at least 100 μ F or more of bulk power supply decoupling at the point where power is connected to the Data Pump circuit.

Digital Section

- Keep all digital traces separated from the analog region of the Data Pump layout.
- Provide high frequency decoupling capacitors (0.01 μ F ceramic or monolithic) around the HDX as shown in Figures 12 and 13.
- It is possible to replace the NAND gate (shown in Figure 13) with an AND gate.

Analog Section

The analog section of the PCB consists of the following subsections:

1. ACC and power supply decoupling capacitors
2. Bias Current Generator
3. Voltage Controlled Crystal Oscillator
4. Line Interface Circuit
 - Route digital signals AD0, AD1, FS, DTR, TSGN, TMAG, TCK3M, and AGCKIK on the solder side of the PCB, and route all analog signals on the component side as much as possible.
 - Route the following signal pairs as adjacent traces:
 - TTIP/TRING
 - BTIP/BRING
 - RTIP/RRING
 but keep the pairs separated from each other as much as possible.
 - Do not run the analog ground plane under the transmitter line side to maximize high voltage isolation.

User Interface

The REFCLK and CK6M signals are sensitive to capacitive loading and rise time. Keep the rise time (from 10%-90%) for these signals less than 5 ns.

Figure 11: PCB Layout Guidelines

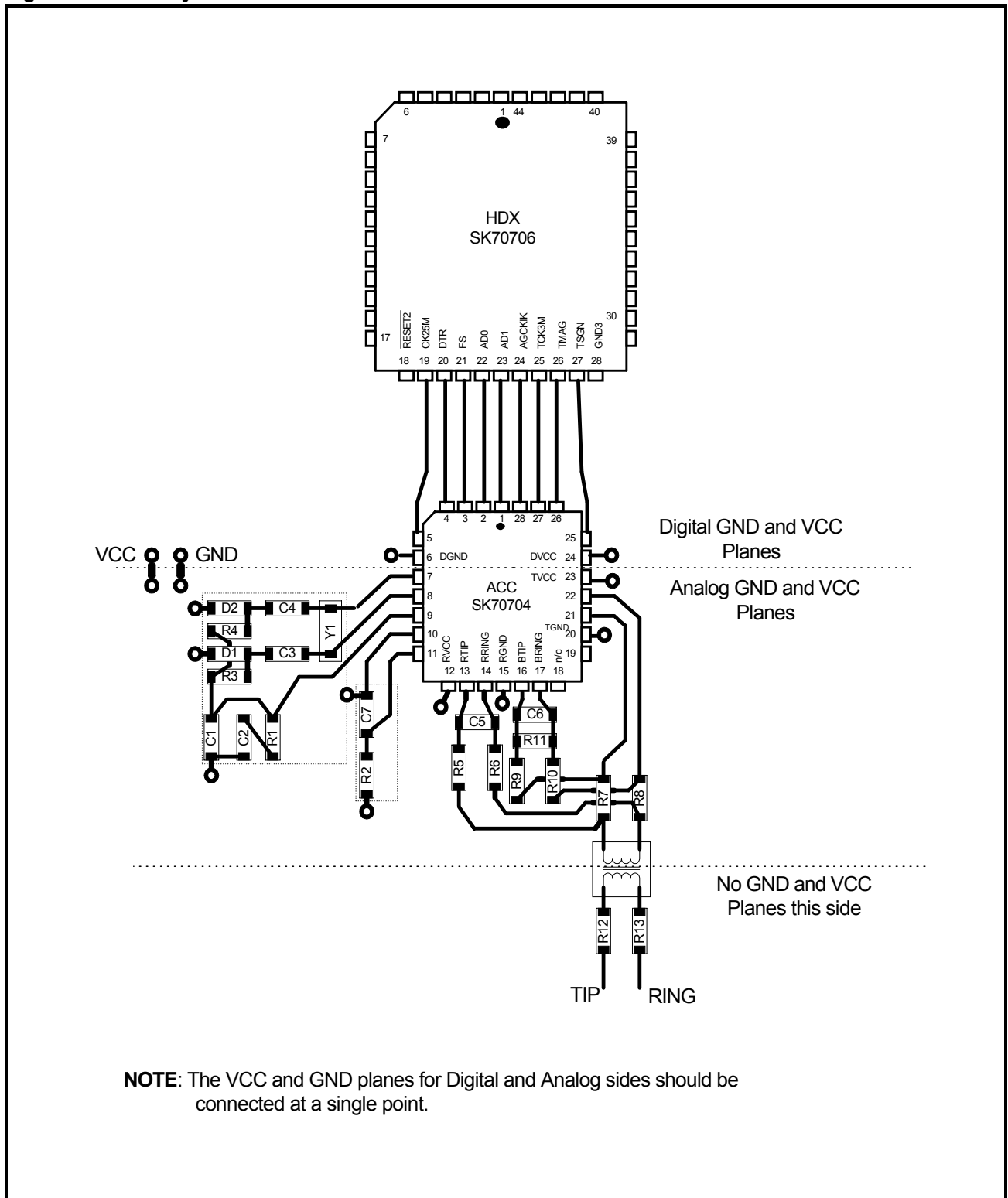

NOTE: The VCC and GND planes for Digital and Analog sides should be connected at a single point.

Figure 12: Typical Support Circuitry for HTU-C Applications

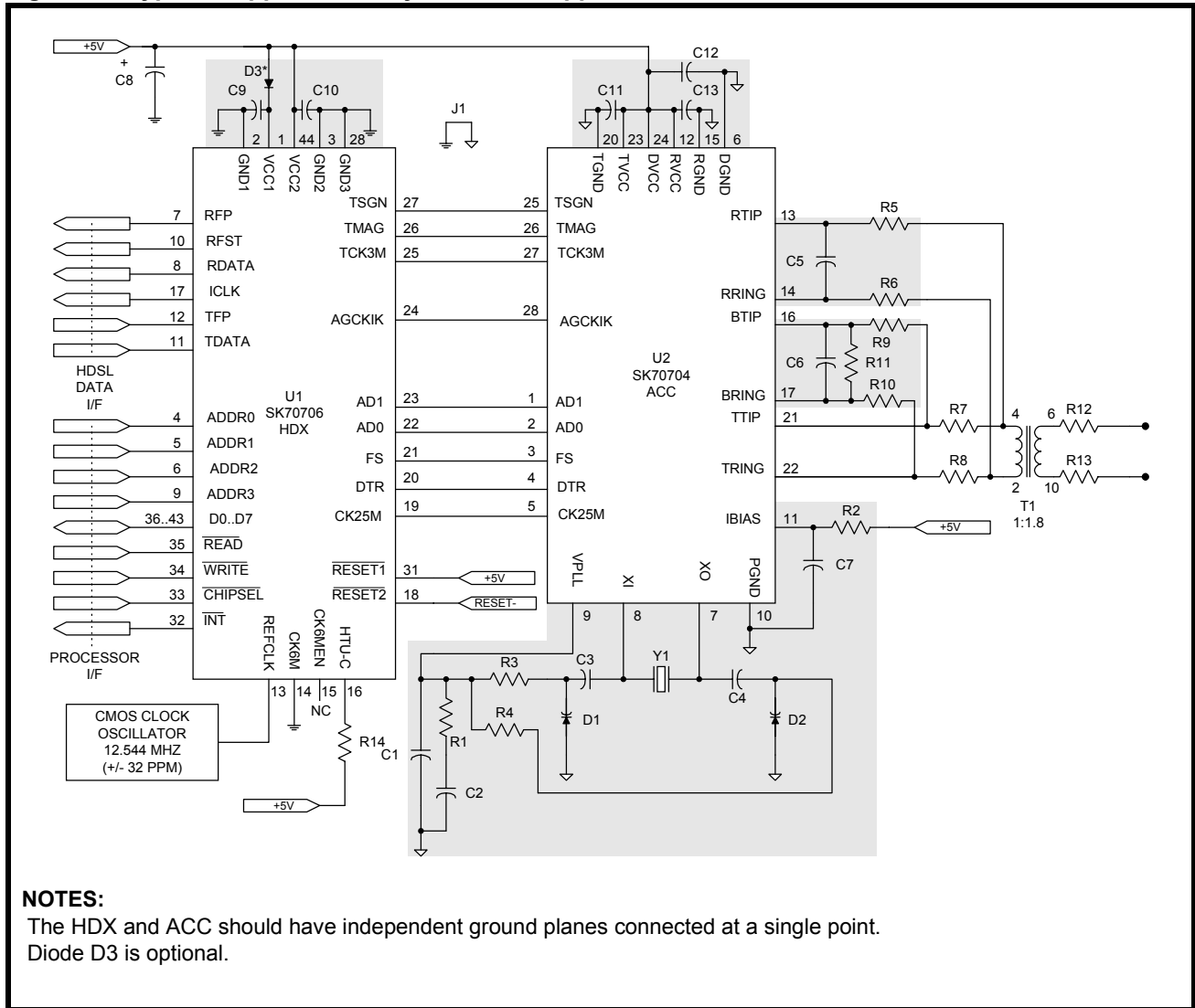

Table 18: Components for Suggested Circuitry (See Figures 12 and 13)

Ref	Description	Ref	Description	Ref	Description
C1, 9, 10	0.01 μ F, ceramic, 10%	R1	5.11 k Ω , 1%	R12, 13	5.6 Ω , line feed fuse resistor (ALFR-2-5.6-1 IRC)
C2	100 μ F, electrolytic, 20% low leakage $\leq 5 \mu$ A @ 25 $^{\circ}$ C	R2	35.7 k Ω , 1%	D1, 2	Varicap diode (Motorola MV209)
C3, 4	1000 pF, ceramic, 20%	R3, 4	20.0 k Ω , 1%	D3	Silicon rectifier diode (1N4001)
C5, 6	470 pF, COG or mica, 10%	R7, 8 ¹	18.2 Ω , 1%	Y1	25.088 MHz crystal (Hy-Q International 80546/1)
C7, 11-13	0.1 μ F, ceramic, 10%	R9, 10	604 Ω , 1%	T1	1:1.8 (Midcom 671-7376 or Pulse Engineering PE-68614)
C8	100 μ F, electrolytic, 20%	R11	909 Ω , 1%		
		R14,R15	10.0 k Ω , 1%		

1. R7, R8 should be 20 Ω when R12 and R13 (the 5.6 Ω fuse links) are not used.

Table 19: Transformer Specifications
(Figures 12 and 13, Reference T1)

Measure	Value	Tolerance
Turns Ratio (IC:Line)	1:1.8	±1%
Secondary Inductance (Line Side)	2.75 mH	±6%
Leakage Inductance	≤ 50 μH	
Interwinding Capacitance	≤ 60 pF	
THD	≤ -70 dB	
Longitudinal Balance	≥ 50 dB	5-196 kHz
Return Loss	≥ 20 dB	40-200 kHz
Isolation	2000 VRMS	
Primary DC Resistance	≤ 3.2 Ω	
Secondary DC Resistance	≤ 6.0 Ω	
Operating Temperature	-40 to +85° C	

Table 20: Crystal Specifications
(Figures 12 and 13, Reference Y1)

Measure	Value	Tolerance
Calibration Frequency	25.088 MHz @CL = 20 pF	+0-+40 ppm
Mode	Fundamental, Parallel Resonance	
Pullability (CL = 24 pF ⇔ 16 pF)	≥ +160 ppm	
Operating Temperature	-40-+85 ° C	
Temperature Drift	≤ ±30 ppm	
Aging Drift	≤ 5 ppm/year	
Series Resistance	≤ 15 Ω	
Drive Level	0.5 mW	
Holder	HC-49	

Figure 13: Typical Support Circuitry for HTU-R Applications

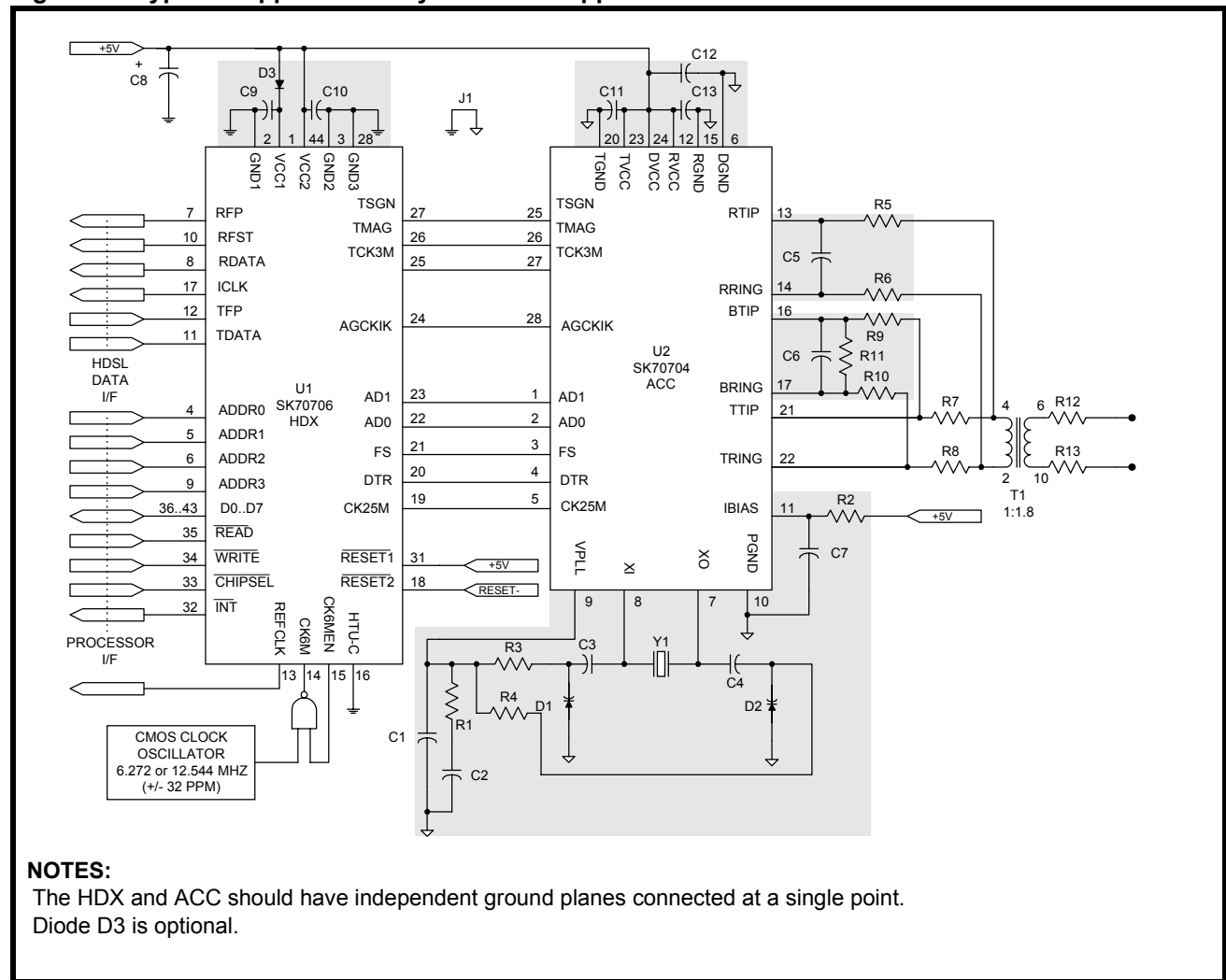

NOTES:
The HDX and ACC should have independent ground planes connected at a single point.
Diode D3 is optional.

Figure 14: SK70706 HDX Control and Status Signals (Stand-alone Mode)

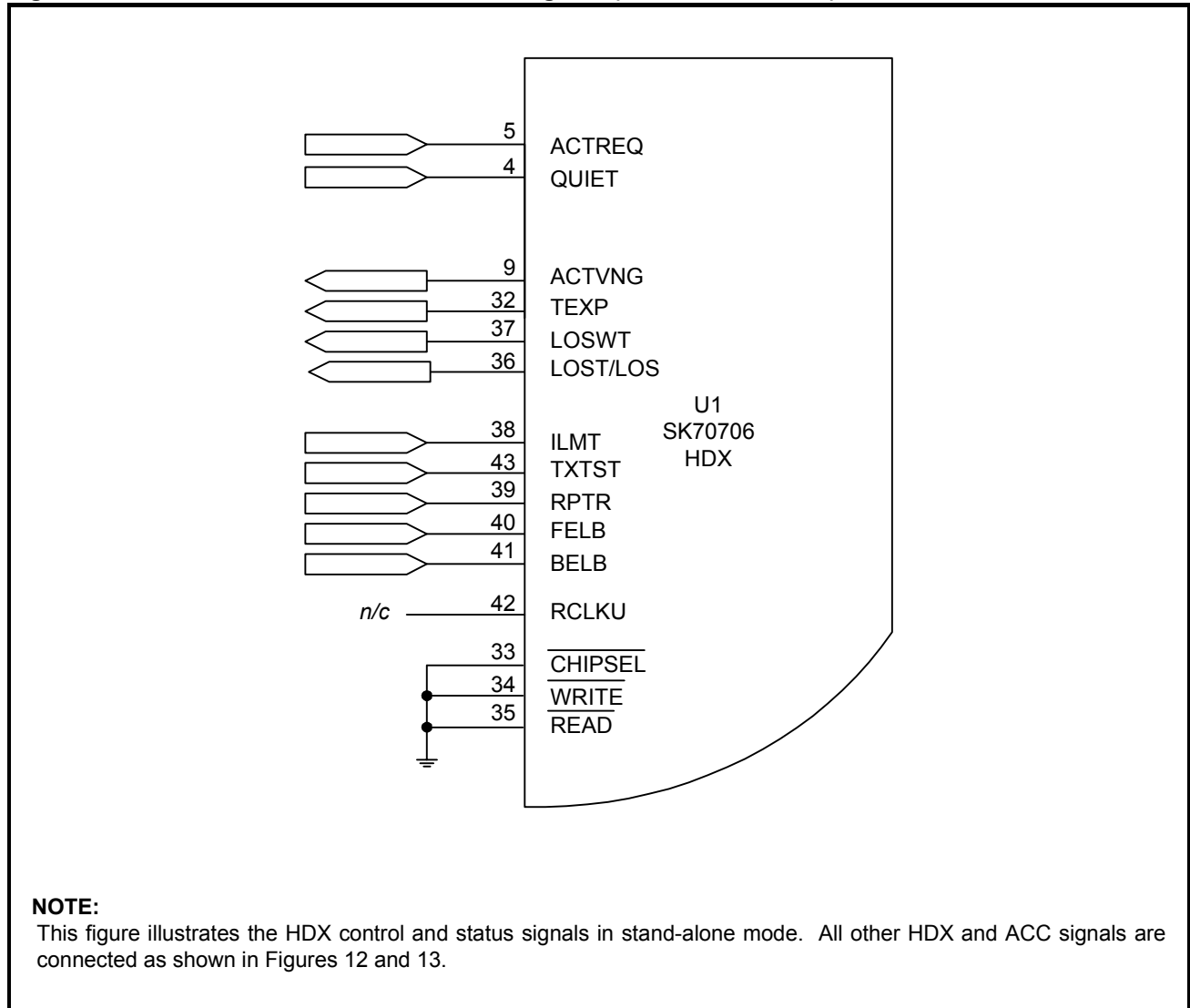

TEST SPECIFICATIONS

NOTE

The minimum and maximum values in Tables 21 through 31 and Figures 14 through 20 represent the performance specifications of the Data Pump and are guaranteed by test, except where noted by design.

Table 21: ACC Absolute Maximum Ratings

Parameter	Symbol	Min	Max	Units
Supply voltage ¹ reference to ground ²	TVCC, RVCC, DVCC	-0.3	+6.0	V
Input voltage ^{2, 3} , any input pin	TVCC, RVCC, DVCC	- 0.3V	VCC + 0.3	V
Continuous output current, any output pin	–	–	±25	mA
Storage temperature	T _{STOR}	-65	+150	° C

CAUTION

Operations at the limits shown may result in permanent damage to the Analog Core Chip. Normal operation at these limits is neither implied nor guaranteed

1. No supply input may have a maximum potential of more than ±0.3 V from any other supply input.
2. TGND = 0V; RGND = 0V; DGND = 0V.
3. TVCC = RVCC = DVCC = VCC.

Table 22: ACC Recommended Operating Conditions

Parameter	Symbol	Min	Typ	Max	Units
DC supply	TVCC, DVCC, RVCC	4.75	5.0	5.25	V
Ambient operating temperature	T _A	-40	+25	+85	° C

Table 23: ACC DC Electrical Characteristics (Over Recommended Range)

Parameter	Sym	Min	Typ ¹	Max	Unit	Test Conditions
Supply current (full operation)	I _{CC}	–	92	120	mA	83 Ω resistor across TTIP and TRING
DVCC current		–	3	6	mA	
RVCC current		–	26	33	mA	
TVCC current		–	63	79	mA	Normal Mode 8+3, 8-3, 8+3, ...
		–	38	48	mA	Off Mode
Input Low voltage	V _{IL}	–	–	0.5	V	I _{IL} < 40 μA
Input High voltage	V _{IH}	4.5	–	–	V	I _{IH} < 40 μA
Output Low voltage	V _{OL}	–	–	0.2	V	I _{OL} < 40 μA
Output High voltage	V _{OH}	4.5	–	–	V	I _{OH} < 40 μA

1. Typical values are at 25° C and are for design aid only; not guaranteed and not subject to production testing.
2. Applies to pins 3, 4, 25, 26 and 27.

Table 23: ACC DC Electrical Characteristics (Over Recommended Range) – continued

Parameter	Sym	Min	Typ ¹	Max	Unit	Test Conditions
Input leakage current ²	IIL	–	–	±50	µA	0 < VIN < VCC
Input capacitance (individual pins)	CIN	–	12	–	pF	
Load capacitance (REFCLK output)	CLREF	–	–	20	pF	

1. Typical values are at 25° C and are for design aid only; not guaranteed and not subject to production testing.
 2. Applies to pins 3, 4, 25, 26 and 27.

Table 24: ACC Transmitter Electrical Parameters (Over Recommended Range)

Parameters	Sym	Min	Typ	Max	Unit	Test Conditions
Isolated pulse height at TTIP, TRING		+2.455	+2.640	+2.825	Vp	TDATA High, TFP Low (+3)
		-2.825	-2.640	-2.455	Vp	TDATA Low, TFP Low (-3)
		+0.818	+0.880	+0.941	Vp	TDATA High, TFP High (+1)
		-0.941	-0.880	-0.818	Vp	TDATA Low, TFP High (-1)
Setup time (TSGN, TMAG)	tTSM _{SU}	5	–	–	ns	
Hold time (TSGN, TMAG)	tTSM _H	12	–	–	ns	

1. Pulse amplitude measured across a 135 Ω resistor on the line side of the transformer using the application circuit shown in Figure 12 and Table 18.

Figure 15: ACC Normalized Pulse Amplitude Transmit Template

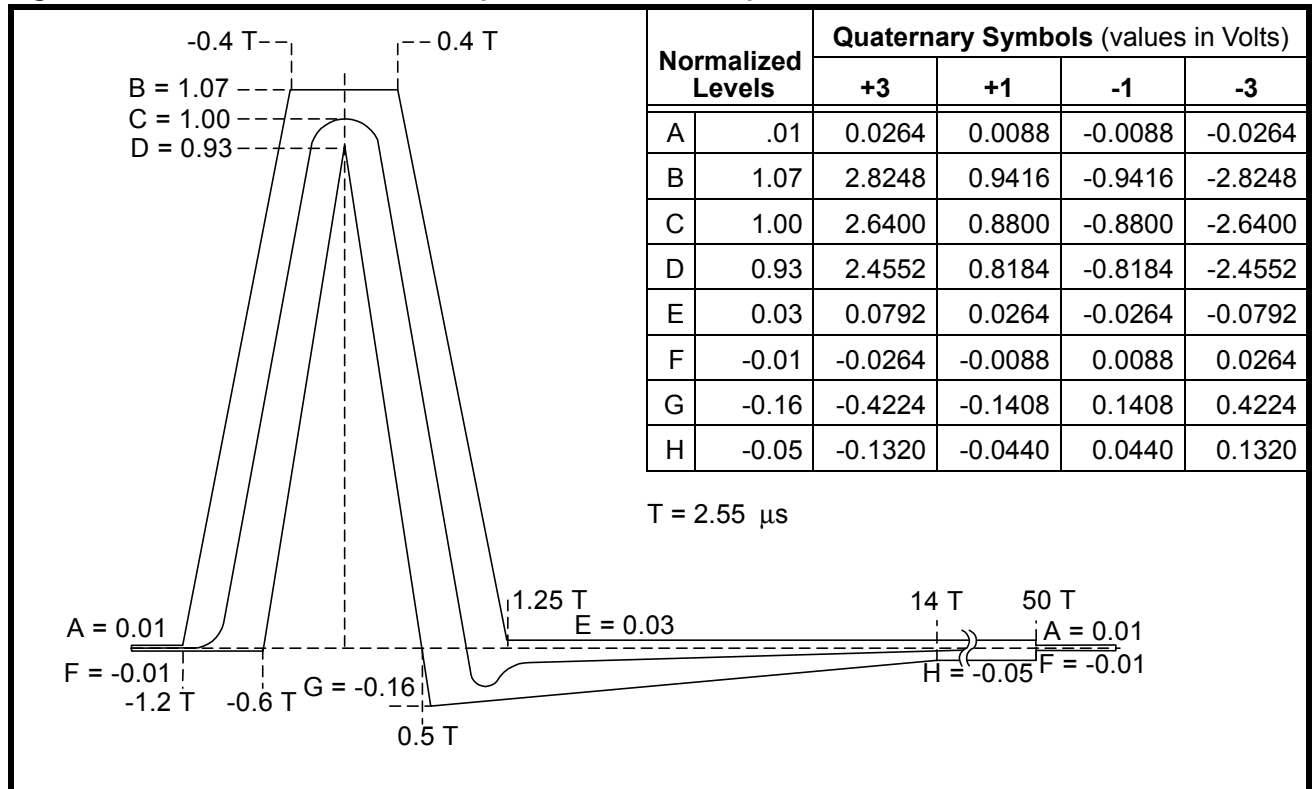

Figure 16: ACC Transmitter Timing

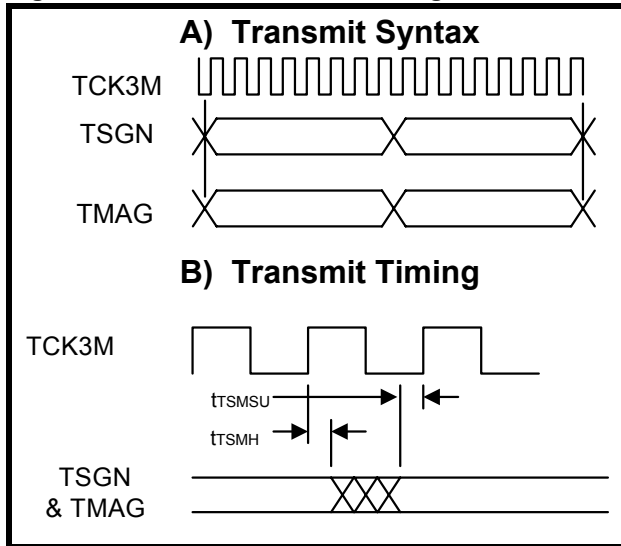

Figure 17: ACC Transmit Power Spectral Density

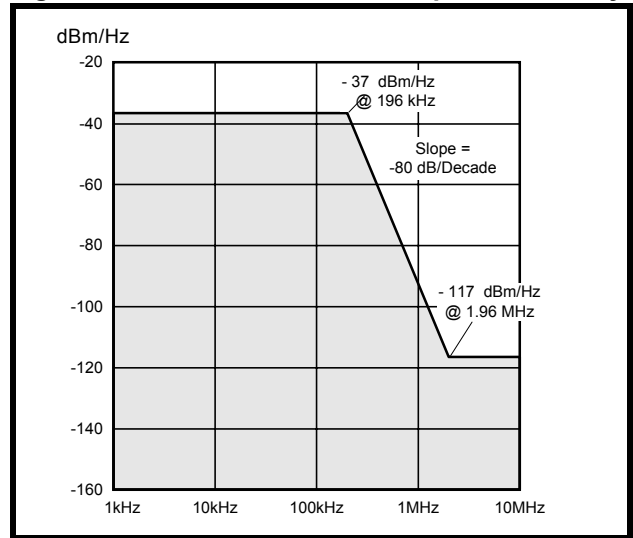

Table 25: ACC Receiver Electrical Parameters (Over Recommended Range)

Parameter	Sym	Min	Typ	Max	Unit	Test Conditions
Propagation delay (AD0, AD1)	t_{ADD}	-	-	25	ns	
Total harmonic distortion		-	-80	-	dB	$V(RTIP, RRING) = 3 V_{pp}$ @ 50 kHz
RTIP, RRING, to BTIP, BRING gain ratio		-	1.0	1%	V/V	

Figure 18: ACC Receiver Syntax and Timing

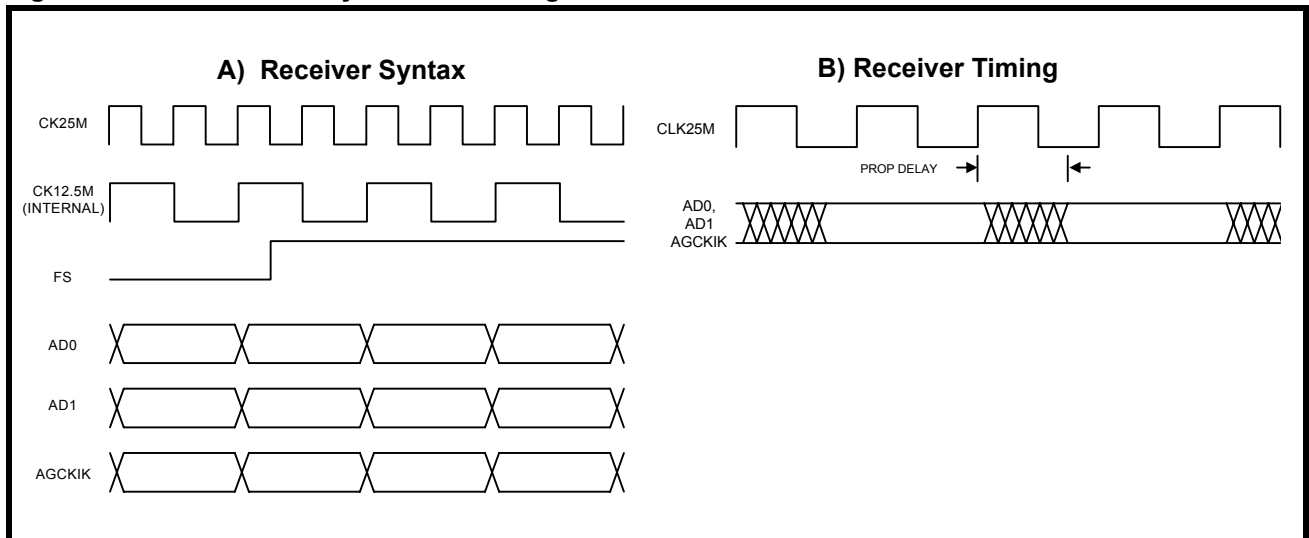

Table 26: HDX Absolute Maximum Ratings

Parameter	Symbol	Min	Max	Units
Supply voltage ¹ reference to ground ²	VCC2, VCC1	-0.3	+6.0	V
Input voltage ² , any input pin	–	- 0.3	VCC2 + 0.3	V
Continuous output current, any output pin	–	–	±25	mA
Storage temperature	T _{STOR}	-65	+150	° C
CAUTION				
Operations at the limits shown may result in permanent damage to the HDSL Digital Transceiver (HDX). Normal operation at these limits is neither implied nor guaranteed				
1. The maximum potential between VCC2 and VCC1 must never exceed ±1.2 V.				
2. GND3 = 0V; GND2 = 0V; GND1 = 0V.				

Table 27: HDX Recommended Operating Conditions

Parameter	Symbol	Min	Typ	Max	Units
DC supply	VCC1 ¹	3.95	5.0	5.25	V
	VCC2	4.75	5.0	5.25	V
	VCC2-VCC1	-0.25	–	+0.9	V
Ambient operating temperature	T _A	-40		+85	° C
1. To derive this supply, a 1N4001 (or equivalent) diode may be connected between VCC2 and VCC1 as shown in Figures 12 and 13. The diode should be selected to meet VCC1 minimum specifications.					

Table 28: HDX DC Electrical Characteristics (Over Recommended Range)

Parameter	Sym	Min	Typ ¹	Max	Unit	Test Conditions
Supply current (full operation)		–	100	175	mA	
Input Low voltage	V _{IL}	–	–	0.5	V	I _{IL} < 40 μA
Input High voltage	V _{IH}	4.0	–	–	V	I _{IH} < 40 μA
Output Low voltage	V _{OL}	–	–	GND +0.3	V	I _{OL} < 40 μA
Output High voltage	V _{OH}	VCC2-0.5	–	–	V	I _{OH} < 40 μA
Input leakage current ²	I _{IL}	–	–	±50	μA	0 < V _{IN} < VCC ₂
Tristate leakage current ³	I _{TOL}	–	–	±30	μA	0 < V < VCC ₂
Input capacitance (individual pins)	C _{IN}	–	12	–	pF	
Load capacitance (REFCLK output)	C _{LREF}	–	–	15	pF	
1. Typical values are at 25° C and are for design aid only; not guaranteed and not subject to production testing.						
2. Applies to pins 4, 5, 11, 12, 14, 16, 18, 19, 22, 23, 24, 29, 31, 33, 34 and 35. Applies to pins 5, 6, 9, 13, and 36-43, when configured as inputs.						
3. Applies to pins 7, 8, 10, 15, 17, 30, 32 and 36-43, when tristated.						

Table 29: HDX/HDSL Data Interface Timing Specifications (See Figure 18)

Parameter	Symbol	Min	Typ ¹	Max	Unit
ICLK frequency	f _{ICLK}	–	784	–	kHz
REFCLK frequency	f _{REFCLK}	–	12.544	–	MHz
REFCLK frequency tolerance (HTU-C Mode)	tol _{RCLK}	-32	0	+32	ppm
CK6M frequency tolerance (HTU-R Mode) ²	tol _{CK6M}	-32	0	+32	ppm
ICLK pulse width high	t _{IPW}	–	638	–	ns
Transition time on any digital output ³	t _{TO}	–	5	10	ns
Transition time on any digital input	t _{TI}	–	–	25	ns
TDATA, TFP setup time to ICLK rising edge	t _{TSU}	100	–	–	ns
TDATA, TFP hold time from ICLK rising edge	t _{TH}	100	–	–	ns
RDATA, RFP, RFST delay from ICLK falling edge	t _{TD}	0	–	150	ns
TFP pulse width ⁴	t _{TFPW}	1248	1276	1304	ns
TFP falling edge to ICLK rising edge ⁴	t _{TFIR}	480	–	610	ns
TFP setup time to REFCLK rising edge ⁴	t _{TSUR}	25	–	–	ns

1. Typical values are at 25° C and are for design aid only; not guaranteed and not subject to production testing.
2. CK6M must meet this tolerance about an absolute frequency of 6.272000 MHz or 12.544000 MHz in HTU-R mode.
3. Measured with 15 pF load.
4. These parameters apply only to an HTU-C mode Data Pump programmed for repeater applications as shown in Figure 19.

Figure 19: HDX/HDXL Data Interface Timing

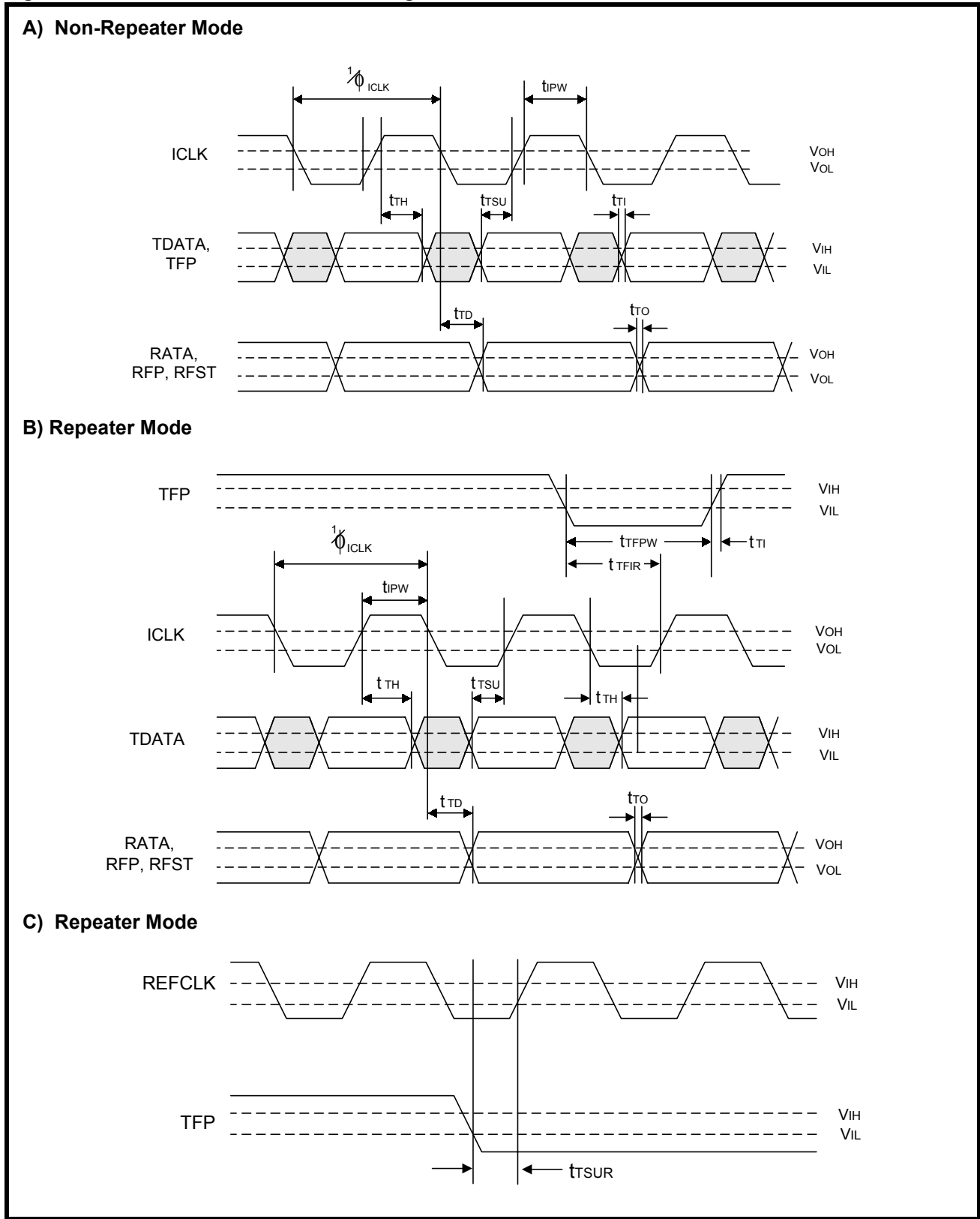

Table 30: HDX/Microprocessor Interface Timing Specifications (See Figures 19 and 20)

Parameter	Symbol	Min	Typ	Max	Unit
RESET $\bar{2}$ pulse width Low	tRPWL	0.1	–	1,000	μ s
RESET $\bar{2}$ to INT clear (10 k Ω resistor from INT to VCC2)	tINTH	–	–	300	ns
RESET $\bar{2}$ to data tristate on D0-7	tDTHZ	–	–	100	ns
CHIPSEL pulse width Low	tCSPWL	200	–	–	ns
CHIPSEL Low to data active on D0-7	tCDLZ	–	–	80	ns
CHIPSEL High to data tristate on D0-7	tCDHZ	–	–	80	ns
READ pulse width Low	tRSPWL	100	–	–	ns
READ Low to data active	tRDLZ	–	–	80	ns
READ High to data tristate	tRDHZ	–	–	80	ns
Address to valid data	tPRD	–	–	80	ns
Address setup to WRITE rising edge	tASUW	20	–	–	ns
Address hold from WRITE rising edge	tAHW	10	–	–	ns
WRITE pulse width Low	tWPWL	100	–	–	ns
Data setup to WRITE rising edge	tDSUW	20	–	–	ns
Data hold from WRITE rising edge	tDHW	10	–	–	ns
READ High to INT clear when reading register RD0	tINTR	–	–	400	ns

1. Timing for all outputs assumes a maximum load of 30 pF.
 2. “Address” refers to input signals CHIPSEL, A0, A1, A2, and A3. “Data” refers to I/O signals D0, D1, D2, D3, D4, D5, D6, and D7.

Table 31: General System and Hardware Mode Timing

Parameter	Min	Typ ¹	Max	Unit	
Throughput delay	TDATA to TTIP/TRING	–	10.2	12.5	μ s
	RTINP/RRING to RDATA	–	53.6	72	μ s
Hardware Mode	“ACTREQ” input transitional pulse width (High or Low)	5	–	–	μ s
	“QUIET” transitional pulse width (High-to-Low)	5	–	–	μ s

1. Typical values are at 25 °C and are for design aid only; not guaranteed and not subject to production testing.

Figure 20: RESET and INTERRUPT Timing (μ P Control Mode)

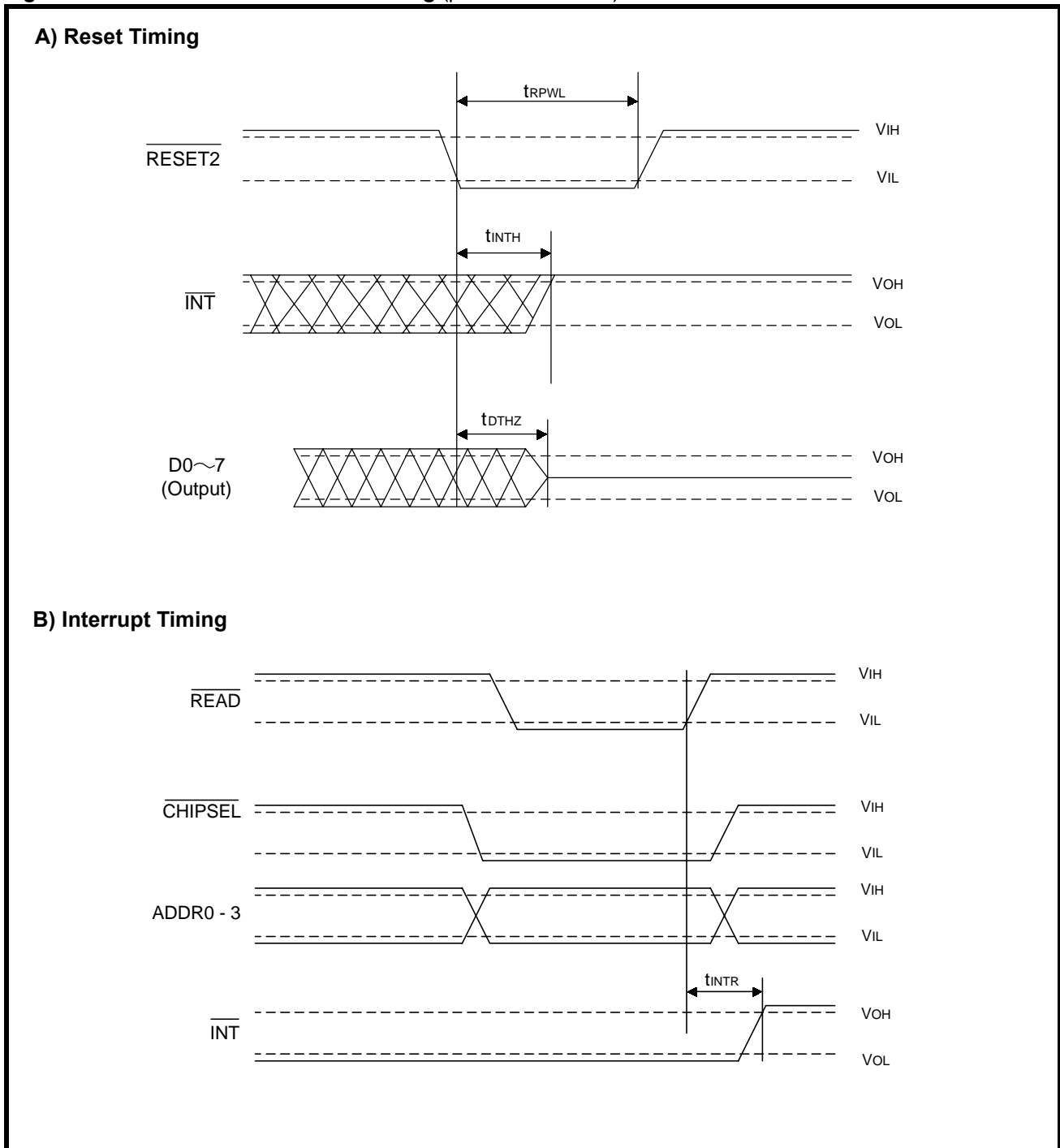
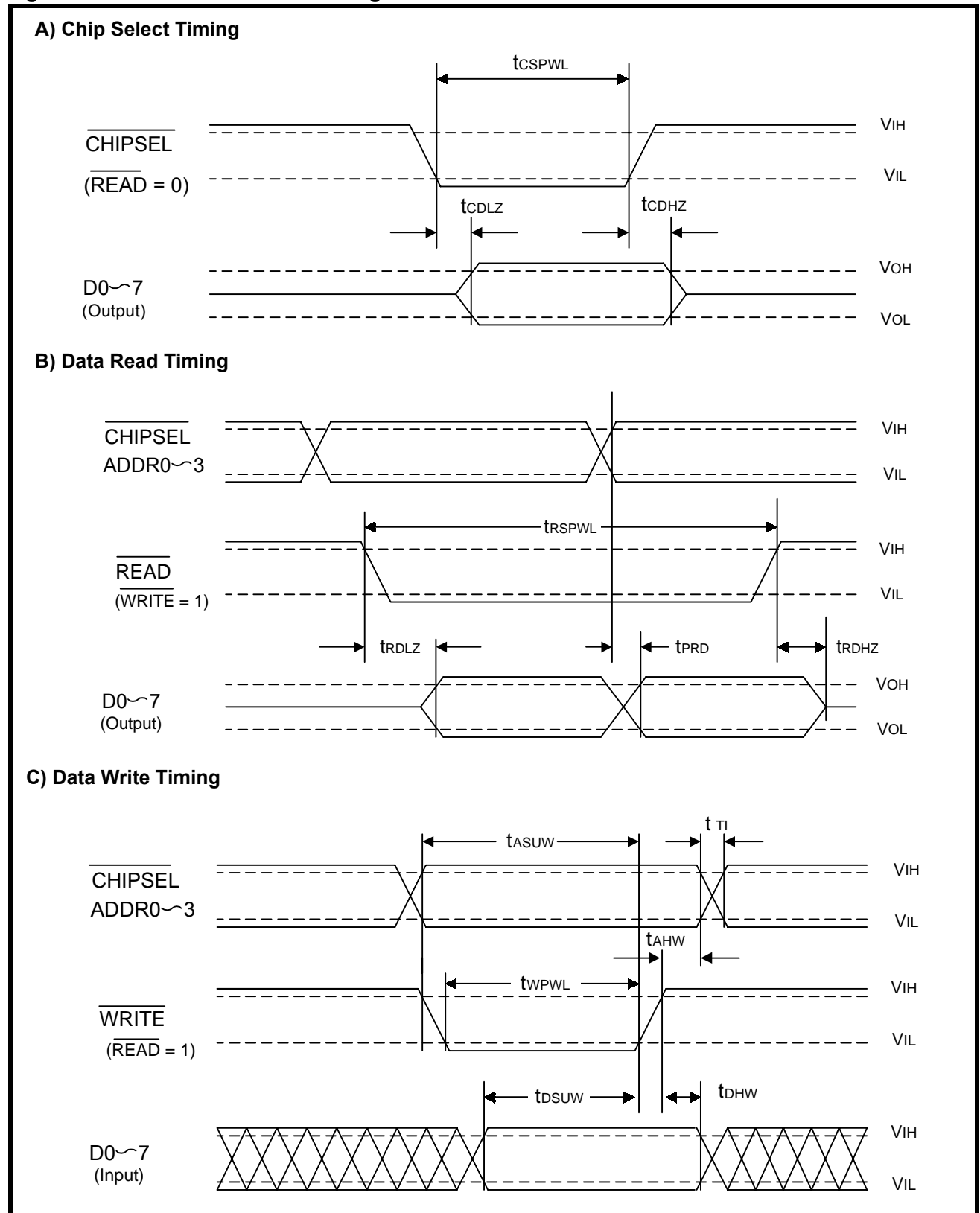

Figure 21: Parallel Data Channel Timing



NOTES
